

Waste Isolation Pilot Plant

Geotechnical Analysis Report For July 2012 – June 2013

U.S. Department of Energy

June 2014



This page was intentionally left blank.

This document has been submitted as required to:

U.S. Department of Energy
Office of Scientific and Technical Information
PO Box 62
Oak Ridge, TN 37831
(865) 576-8401

Additional information about this document may be obtained by calling 1-800-336-9477

Unlimited, publicly available full-text scientific and technical reports produced since 1991 are available online at Information Bridge (www.osti.gov/bridge).

U.S Department of Energy and its contractors may obtain full-text reports produced prior to 1991 in paper form for a processing fee from:

U.S. Department of Energy
Office of Scientific and Technical Information
P.O. Box 62
Oak Ridge, TN 37831-0062
Telephone: (865) 576-8401
Facsimile: (865) 576-5728
E-mail: reports@osti.gov

Available for sale to the public from:

U.S. Department of Commerce
National Technical Information Service
5301 Shawnee Rd
Alexandra, VA 22312
Phone: (800) 553-6847 or (703) 605-6000
Fax: (703) 605-6900
Email: info@ntis.gov

This page was intentionally left blank.

Geotechnical Analysis Report for July 2012 – June 2013
DOE/WIPP-14-3516, Vol. 1

FOREWORD AND ACKNOWLEDGMENTS

This report contains an assessment of the geotechnical status of the Waste Isolation Pilot Plant (WIPP). During the excavation of the principal underground access and experimental areas, the status was reported quarterly. Since 1987, when the initial construction phase was completed, reports have been published annually. This report presents and analyzes data collected from July 1, 2012, to June 30, 2013.

This Geotechnical Analysis Report (GAR) was written to meet the needs of several audiences. It satisfies requirements contained in the WIPP Hazardous Waste Facility Permit¹ (HWFP) and the Certification of Compliance² with Subparts B and C, Title 40 *Code of Federal Regulations* (CFR) Part 191, "Environmental Radiation Protection Standards for Management and Disposal of Spent Nuclear Fuel, High-Level and Transuranic Radioactive Wastes." It focuses on the geotechnical performance of the various components of the underground facility, including the shafts, shaft stations, access drifts, and waste disposal areas. The results of investigations of excavation effects and other geotechnical studies are also included.

The report compares the geotechnical performance of the repository to the design criteria. It describes the techniques that were used to acquire the data. The depth and breadth of the evaluation of the different components of the underground facility vary according to the types and quantities of data available and the complexity of the recorded geotechnical responses. Graphic documentation of data and tabular documentation of instrument history can be provided upon request.

This GAR was prepared by Nuclear Waste Partnership LLC (NWP) for the U.S. Department of Energy (DOE), Carlsbad Field Office (CBFO), in Carlsbad, New Mexico. Work was supported by the DOE under Contract No. DE-EM0001971.

¹ New Mexico Environment Department (NMED), 2012, Waste Isolation Pilot Plant Hazardous Waste Facility Permit, NM4890139088-TSDF, Santa Fe, NM

² U.S. Environmental Protection Agency, 1998, "Criteria for the Certification and Recertification of the Waste Isolation Pilot Plant's Compliance with the Disposal Regulations: Certification Decision," Federal Register, Vol. 63, No. 95, pp. 27354, May 18, 1998, Washington, DC

This page was intentionally left blank.

Geotechnical Analysis Report for July 2012 – June 2013
DOE/WIPP-14-3516, Vol. 1

TABLE OF CONTENTS

ACRONYMS AND ABBREVIATIONS	11
1.0 INTRODUCTION	13
1.1 Location and Description	13
1.2 Mission.....	16
1.3 Development Status	16
1.4 Purpose and Scope of Geomechanical Monitoring Program	17
1.4.1 Instrumentation	18
1.4.2 Data Acquisition	19
1.4.3 Data Evaluation.....	20
1.4.4 Data Errors.....	21
2.0 GEOLOGY.....	21
2.1 Regional Stratigraphy	21
2.1.1 Permian.....	21
2.1.2 Triassic.....	23
2.1.3 Quaternary	23
2.2 Underground Facility Stratigraphy	26
2.2.1 Disposal Horizon Stratigraphy of Panels 1, 2, 7, and 8	26
2.2.2 Disposal Horizon Stratigraphy of Panels 3, 4, 5, and 6	29
2.2.3 Northeast Area Stratigraphy.....	29
3.0 PERFORMANCE OF SHAFTS AND KEYS.....	31
3.1 Salt Shaft	31
3.1.1 Shaft Observations.....	33
3.1.2 Instrumentation	33
3.2 Waste Shaft	36
3.2.1 Shaft Observations.....	38
3.2.2 Instrumentation	38
3.3 Exhaust Shaft	40
3.3.1 Exhaust Shaft Observations.....	41
3.4 Air Intake Shaft	48
3.4.1 Shaft Performance	48
4.0 PERFORMANCE OF SHAFT STATIONS	53
4.1 Salt Shaft Station	53
4.1.1 Modifications to Excavation and Ground Control Activities	53
4.1.2 Instrumentation	53
4.2 Waste Shaft Station	56
4.2.1 Modifications to Excavation and Ground Control Activities	56
4.2.2 Instrumentation	58
4.3 Air Intake Shaft Station	60
4.3.1 Modifications to Excavation and Ground Control Activities	60
4.3.2 Instrumentation	60

Geotechnical Analysis Report for July 2012 – June 2013
DOE/WIPP-14-3516, Vol. 1

5.0	PERFORMANCE OF ACCESS DRIFTS	60
5.1	Modifications to Excavation and Ground Control Activities	60
5.2	Instrumentation	60
5.2.1	Extensometers	60
5.2.2	Convergence Points.....	62
5.3	Analysis of Convergence Point and Extensometer Data.....	65
5.4	Excavation Performance.....	68
6.0	PERFORMANCE OF WASTE DISPOSAL AREA	68
6.1	History.....	68
6.2	Modifications to Excavations and Ground Control Activities	69
6.3	Instrumentation	70
6.4	Excavation Performance.....	72
6.5	Analysis of Extensometer and Convergence Point Data	72
7.0	PERFORMANCE OF THE SALT DISPOSAL INVESTIGATIONS AND SALT DEFENSE DISPOSAL INVESTIGATIONS AREAS.....	73
7.1	Ground Control Program.....	73
7.2	Instrumentation	73
7.3	Analysis of Convergence Point Data	73
7.4	Excavation Performance.....	73
8.0	GEOSCIENCE PROGRAM	74
8.1	Observation Hole Inspections	74
8.2	Fracture Mapping.....	77
9.0	SUMMARY	78
10.0	REFERENCES	79

Geotechnical Analysis Report for July 2012 – June 2013
DOE/WIPP-14-3516, Vol. 1

LIST OF TABLES

Table 1 - 1 Geomechanical Instrumentation System.....	19
Table 4 - 1 Closure Rates in the Salt Shaft Station	56
Table 4 - 2 Roof Beam Displacement in the Salt Shaft Station	56
Table 4 - 3 Summary of Roof Extensometers in Waste Shaft Station	58
Table 4 - 4 Closure Rates in the Waste Shaft Station	58
Table 5 - 1 Summary of Modifications and Ground Control Activities in the.....	61
Table 5 - 2 New and Replacement Convergence Points Installed	63
Table 5 - 3 Vertical Closure Rate Changes in Excess of Twenty Percent in the Access Drifts	67
Table 6- 1 Summary of Modifications and Ground Control Activities in the.....	70
Table 9 - 1 Comparison of Excavation Performance to System Design Requirements.	79

LIST OF FIGURES

Figure 1 - 1 WIPP Location	14
Figure 1 - 2 Underground Mining and Waste Disposal Configuration as of June 30, 2013.....	15
Figure 2 - 1 Regional Geology	25
Figure 2 - 2 Repository Level Stratigraphy of Panels 1, 2, 7, and 8	28
Figure 2 - 3 Repository Level Stratigraphy of Panels 3, 4, 5, and 6	30
Figure 3 - 1 Salt Shaft Stratigraphy	32
Figure 3 - 2 Salt Shaft Instrumentation (Without Shaft Key).....	34
Figure 3 - 3 Salt Shaft Key Instrumentation.....	35
Figure 3 - 4 Waste Shaft Stratigraphy	37
Figure 3 - 5 Waste Shaft Instrumentation (Without Shaft Key).....	39
Figure 3 - 6 Waste Shaft Key Instrumentation.....	40
Figure 3 - 7 Exhaust Shaft Stratigraphy	43
Figure 3 - 8 Sample Intake of Exhaust Shaft Air Monitoring System.....	44
Figure 3 - 9 Diagram of Exhaust Shaft Fixtures and Seepage Zones (Upper 200 ft)	45
Figure 3 - 10 Location of Interception Wells and Storage Containers	46
Figure 3 - 11 Water Removed from the Exhaust Shaft Catch Basin and the Interception Well System	49
Figure 3 - 12 Exhaust Shaft Instrumentation (Without Shaft Key)	50
Figure 3 - 13 Exhaust Shaft Key Instrumentation	51
Figure 3 - 14 Air Intake Shaft Stratigraphy	52
Figure 4 - 1 Salt Shaft Station Stratigraphy	54
Figure 4 - 2 Salt Shaft Station Instrumentation after Roof Beam Excavation	55
Figure 4 - 3 Waste Shaft Station Stratigraphy	57
Figure 4 - 4 Waste Shaft Station Instrumentation after Roof Beam Excavation	59
Figure 5 - 1 Typical Convergence Point Array Configurations Showing Anchor Designations	66
Figure 6 - 1 Location of Geomechanical Instruments in Panels 6 and 7	71
Figure 8 - 1 Example of Observation Hole Layout at Lower Horizon.....	75
Figure 8 - 2 Typical Fracture Pattern at Lower Horizon.....	76
Figure 8 - 3 Example Observation Hole Layout at Upper Horizon.....	76
Figure 8 - 4 Typical Fracture Patterns at Upper Horizon.....	77

This page was intentionally left blank.

Geotechnical Analysis Report for July 2012 – June 2013
DOE/WIPP-14-3516, Vol. 1

ACRONYMS AND ABBREVIATIONS

ASTM	American Society for Testing and Materials
bp	before present
bsc	below shaft collar
CAO	Carlsbad Area Office
CBFO	Carlsbad Field Office
CFR	Code of Federal Regulations
CH	contact-handled
cm	centimeter(s)
DOE	U.S. Department of Energy
EPA	U.S. Environmental Protection Agency
ft	foot (feet)
GAR	Geotechnical Analysis Report
GIS	geomechanical instrumentation system
HWFP	Hazardous Waste Facility Permit
in	inch(es)
km	kilometer(s)
kPa	kilopascal(s)
kVA	kilovolt ampere(s)
LANL	Los Alamos National Laboratory
lb	pound(s)
m	meter(s)
Ma	million years
MB	marker bed
μin	10-6 inch(es)
NMED	New Mexico Environment Department
NWP	Nuclear Waste Partnership LLC
OMB	orange marker bed
psi	pound(s) per square inch

Geotechnical Analysis Report for July 2012 – June 2013
DOE/WIPP-14-3516, Vol. 1

RH	remote-handled
SDI	Salt Disposal Investigation
SDDI	Salt Defense Disposal Investigation
SPDV	Site and Preliminary Design Validation
TRU	transuranic
WIPP	Waste Isolation Pilot Plant
VOC	Volatile Organic Compound
yr(s)	year(s)

Geotechnical Analysis Report for July 2012 – June 2013
DOE/WIPP-14-3516, Vol. 1

1.0 INTRODUCTION

This Geotechnical Analysis Report (GAR) presents and interprets geotechnical data from the underground excavations at the Waste Isolation Pilot Plant (WIPP). The data, which are obtained as part of a regular monitoring program, are used to characterize conditions, to compare actual performance to the design criteria and to evaluate and forecast the performance of the underground excavations.

GARs have been available to the public since 1983. During the Site and Preliminary Design Validation (SPDV) Program, the architect/engineer for the project produced these reports quarterly to document the geomechanical performance during and immediately after early excavations of the underground facility. Since completion of the construction phase of the project in 1987, the management and operating contractor for the facility has prepared these reports annually. This report describes the performance and condition of selected areas from July 1, 2012, to June 30, 2013. It is divided into nine chapters.

Chapter 1 provides background information on WIPP, its mission, and the purpose and scope of the geomechanical monitoring program. Chapter 2 describes the local and regional geology of the WIPP site. Chapters 3 and 4 describe the geomechanical instrumentation in the shafts and shaft stations, present the data collected by that instrumentation, and provide interpretation of these data. Chapters 5 and 6 present the results of geomechanical monitoring in the two main portions of the WIPP underground (the access drifts and the waste disposal area). Chapter 7 introduces the Salt Disposal and Salt Defense Disposal Investigation Areas. Chapter 8 discusses the results of the Geoscience Program, which include fracture mapping and observation hole observations. Chapter 9 summarizes the results of geomechanical monitoring and compares the current excavation performance to the design requirements. Chapter 10 lists references.

1.1 Location and Description

WIPP is located in southeastern New Mexico, 26 miles (42 kilometers [km]) east of Carlsbad (Figure 1-1). The surface facilities were built on the flat to gently rolling terrain that is characteristic of the Los Medaños area. The underground facility is being excavated approximately 2,150 feet (ft) (655 meters [m]) beneath the surface in the Salado Formation. Figure 1-2 shows a plan view of the underground configuration of WIPP as of June 30, 2013.

Geotechnical Analysis Report for July 2012 – June 2013
DOE/WIPP-14-3516, Vol. 1

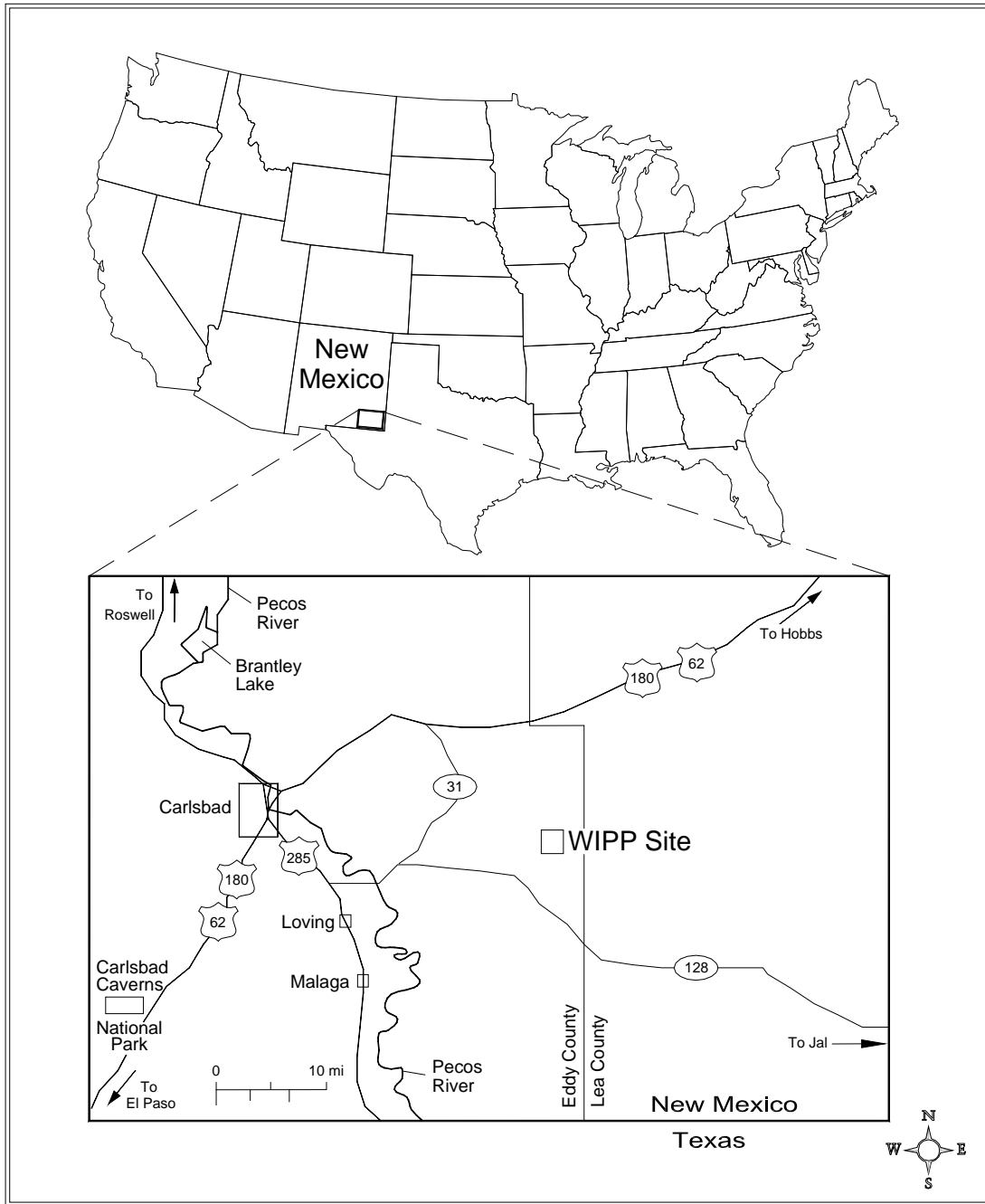

Figure 1 - 1 WIPP Location

Geotechnical Analysis Report for July 2012 – June 2013
DOE/WIPP-14-3516, Vol. 1

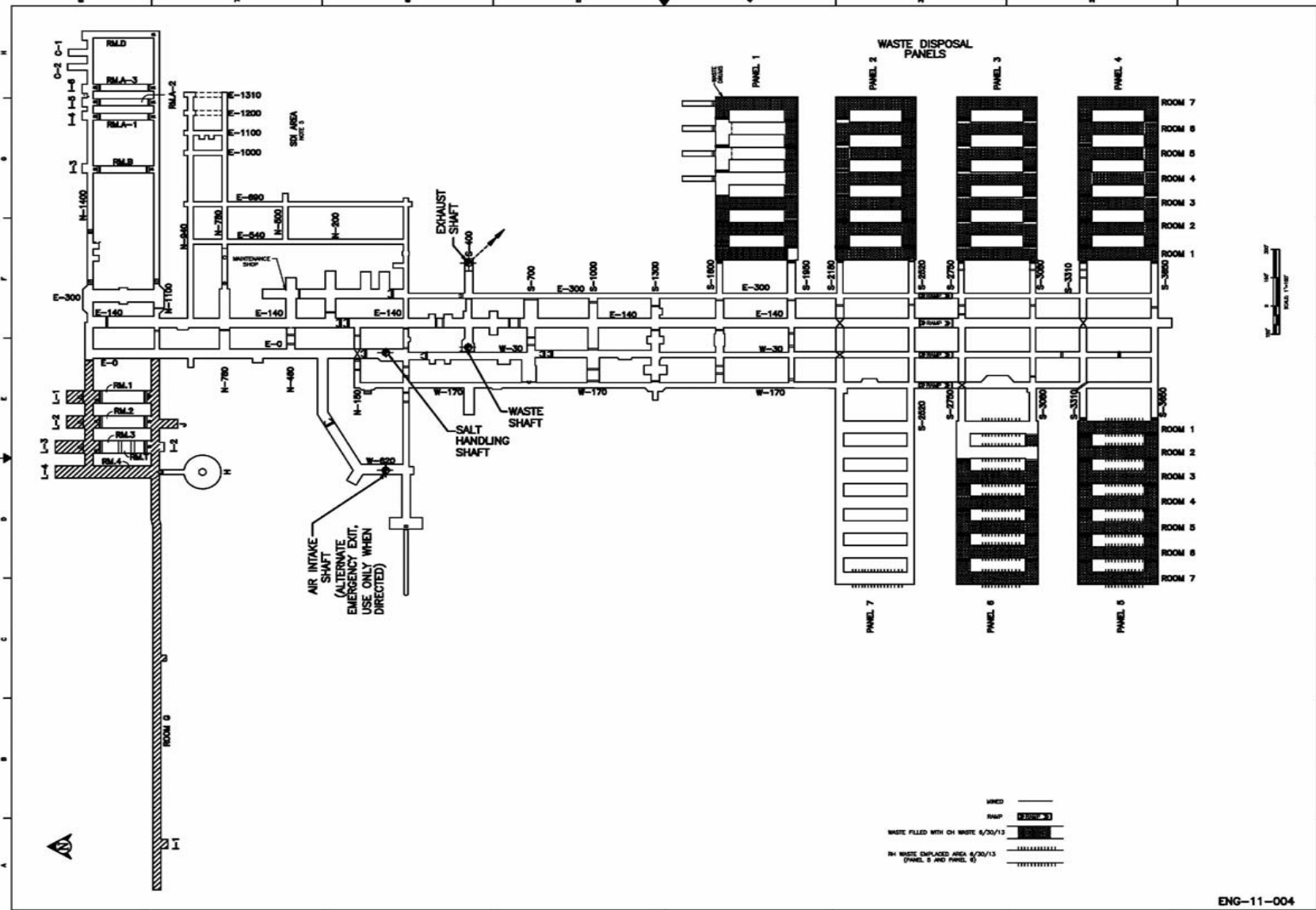

Figure 1 - 2 Underground Mining and Waste Disposal Configuration as of June 30, 2013

Geotechnical Analysis Report for July 2012 – June 2013
DOE/WIPP-14-3516, Vol. 1

1.2 Mission

In 1979 Congress authorized WIPP (Public Law 96-164, National Security and Military Applications of Nuclear Energy Authorization Act of 1980) to provide ". . . a research and development facility to demonstrate the safe disposal of radioactive wastes resulting from the defense activities and programs of the United States exempted from regulation by the Nuclear Regulatory Commission." To fulfill this mission, the DOE constructed a full-scale facility to demonstrate both technical and operational principles of the permanent disposal of transuranic (TRU) and TRU mixed wastes. Technical aspects are those concerned with the design, construction, and performance of the subsurface excavations. Operational aspects refer to the receiving, handling, and emplacement of TRU wastes in the facility. The facility was first used for *in situ* studies and experiments without the use of radioactive waste. WIPP now receives handles, and permanently disposes of TRU waste and TRU mixed waste.

1.3 Development Status

To fulfill its mission, the DOE developed WIPP in a phased manner. The goal of the SPDV phase, begun in 1980, was to characterize the site and obtain *in situ* geotechnical data from underground excavations to determine whether site characteristics and *in situ* conditions were suitable for permanent disposal. During this phase, the Salt Shaft, a ventilation shaft, a drift to the southernmost extent of the proposed waste disposal area, a four-room experimental panel, and access drifts were excavated. Surface-based geological and hydrological investigations were also conducted. The data obtained from the SPDV investigations were reported in the "Summary of the Results of the Evaluation of the WIPP Site and Preliminary Design Validation Program" (DOE, 1983).

Based upon the favorable results of the SPDV investigations, additional activities were initiated in 1983. These included the construction of surface structures, conversion of the ventilation shaft for use as the Waste Shaft, excavation of the Exhaust Shaft, development of additional access drifts to the waste disposal area, excavation of the Air Intake Shaft, and excavation of additional experimental rooms to support research and development. Geotechnical data acquired during this phase were used to evaluate the performance of the excavations in the context of established design criteria (DOE, 1984). Results of these evaluations were reported in *Geotechnical Field Data Reports* (DOE, 1985; DOE, 1986a) and were summarized in the *Design Validation Final Report* (DOE, 1986b).

The *Design Validation Final Report* concluded that the facility, including waste disposal areas, could be developed and operated to fulfill the long-term mission of WIPP (DOE, 1986b). All available information validated the design of underground openings to safely accommodate the permanent disposal of waste under routine operating conditions.

Geotechnical Analysis Report for July 2012 – June 2013
DOE/WIPP-14-3516, Vol. 1

Panel 1 mining began in 1986 and was completed in 1988. Panel 1 was intended to receive waste for an initial operations demonstration and pilot plant phase that was scheduled to start in October 1988; however, the demonstration and pilot plant phase was not put into effect because waste could not be emplaced until permits were acquired.

In October 1996, the DOE submitted to the U.S. Environmental Protection Agency (EPA) a compliance certification application in accordance with 40 CFR Parts 191 and 194, which addressed the long-term (10,000-year) performance criteria for the disposal system. On May 18, 1998, the EPA published the final certification that allowed for the receipt of TRU waste at WIPP. Immediately before this certification, the DOE Carlsbad Area Office (CAO) completed an Operational Readiness Review, which is required by the DOE before the start-up or a process change of any nuclear facility. As a result of the review, the CAO notified the Energy Secretary on April 1, 1998, that WIPP was operationally ready to receive waste. On March 26, 1999, the first shipment of TRU waste was received from Los Alamos National Laboratory (LANL). By the end of June 2013, many additional generator sites had shipped waste to WIPP. The cleanup of several small-quantity generator sites, as well as one large-quantity site (Rocky Flats Environmental Technology Site) is now complete.

Waste disposal in Panels 1, 2, 3, 4 and 5 is complete. Panels 1, 2, and 3 contain only CH waste. The first RH waste shipment arrived January 24, 2007. Panel 4 was the first to receive both CH and RH waste. As of June 30, 2013, waste handling activities included RH disposal in Room 1 of Panel 6 and CH disposal in Room 2 of Panel 6. Mining of Panel 7 was completed in January 2013.

1.4 Purpose and Scope of Geomechanical Monitoring Program

As specified in the WIPP HWFP (NMED, 2012), the purpose of the geomechanical monitoring program is to obtain *in situ* data to support the continuous assessment of the design for underground facilities.

Specifically, the program provides for:

- Early detection of conditions that could affect operational safety.
- Evaluation of disposal room closure that ensures adequate access.
- Guidance for design modifications and remedial actions.
- Data for interpreting the behavior of underground openings, in comparison with the established design criteria.

Geotechnical Analysis Report for July 2012 – June 2013
DOE/WIPP-14-3516, Vol. 1

Data taken by or input into the geomechanical instrumentation system (GIS) are evaluated and reported in this GAR. This annual report fulfills the requirements set forth in Part 4.6.1.2, Attachment A3, Section A2-5b (2) of the WIPP HWFP (NMED, 2011), and 40 CFR §191.14, "Assurance Requirements," implemented through the certification criteria, 40 CFR Part 194.

The Geomechanical Monitoring Program generates the data for four of the compliance monitoring parameters:

- Creep closure and stresses
- Extent of deformation
- Initiation of brittle deformation
- Displacement of deformation features

The instrumentation system for geomechanical monitoring provides data for routine evaluations of safety, stability, and performance of underground openings. *In situ* data are also used to model long-term disposal system performance. Changes resulting from excavations are monitored by routine inspections of selected observation hole arrays and fracture mapping to detect and quantify occurrences of discontinuities such as fractures and bed separations. Analysis of data indicating areas of potential instability allows timely corrective action before they could become safety issues. Other geoscience activities include geologic mapping and sampling, and seismic monitoring.

The GIS provides data that are collected, processed, and stored for analysis. The following subsections briefly describe the major components of the GIS.

1.4.1 Instrumentation

Instrumentation installed for measuring the geomechanical response of the shafts, drifts, and other underground openings includes convergence points, convergence meters, extensometers, rock bolt load cells, pressure cells, strain gauges, piezometers, and joint meters. Table 1-1 lists a summary of the specifications for geomechanical instrumentation.

Geotechnical Analysis Report for July 2012 – June 2013
DOE/WIPP-14-3516, Vol. 1

Table 1 - 1 Geomechanical Instrumentation System

Instrument Type	Measures	Range ¹	Resolution ¹
Sonic probe extensometer	Cumulative deformation	0–2 in	0.001 in
Convergence point (tape extensometer)	Cumulative deformation	2–50 ft	0.001 in
Wire convergence meter	Cumulative deformation	0–3.5 ft	0.001 in
Embedded strain gauge	Cumulative strain	0–3000 $\mu\text{in/in}$	1 $\mu\text{in/in}$
Spot-welded strain gauge	Cumulative strain	0–2500 $\mu\text{in/in}$	1 $\mu\text{in/in}$
Rock bolt load cell	Load	0–50 tons	40 lb
Earth pressure cell	Pressure	0–1000 psi	1 psi
Piezometer	Fluid pressure	0–500 psi	0.5 psi
Joint meter	Cumulative deformation	0–4 in	0.001 in
Vibrating wire extensometer	Cumulative deformation	0–4 in	0.001 in
Wire extensometer	Cumulative deformation	0–20 in	0.001 in
Linear potentiometric extensometer	Cumulative deformation	0–6 in	0.001 in

¹ Manual readout boxes for the instruments were manufactured to render measurements in U.S. customary units. Range and resolution measurement units have not been converted to metric units. Measurements from these instruments have been converted for presentation elsewhere in this report.

1.4.2 Data Acquisition

Geomechanical instruments are read either manually, using portable devices, or remotely by electronically polling the stations from the surface in accordance with approved operating procedures. Remotely read instruments are connected to one of the underground data loggers, and readings are collected by initiating the appropriate polling routine. Upon completion of a verification process, data are transferred to a computer database. Manual readout devices are taken to instrument locations underground. Data are recorded on data sheets and later entered into an electronic database.

The underground data acquisition system consists of instruments, polling devices, and a communications network. Instruments are connected to polling devices that are installed in electrical enclosures near the instrument locations. Polling devices are connected by a data link to a surface computer.

Whether acquired manually or remotely, geomechanical data are entered into the database files of the GIS data processing system. The data processing system consists of computer programs that are used to enter, reduce, and transfer the data to permanent storage files. Additional routines allow access to the permanent storage files for numerical analysis, tabular reporting, and graphical plotting. Copies of the instrumentation database and data plots are available upon request.³

³ Instrumentation data and data plots are presented in "Geotechnical Analysis Report for July 2012-June 2013 Supporting Data" (DOE/WIPP-14-3516 Volume 2).

The document is available upon request from the National Technical Information Service. See page 3 for details and addresses.

1.4.3 Data Evaluation

Rounding and significant digits are used in the data tables of this document. The reference document is American Society for Testing and Materials (ASTM) document ASTM D 6026-06, "Standard Practice for Using Significant Digits in Geotechnical Data."

Closure measurements are acquired manually from convergence point anchors and remotely from convergence meters. Data are presented in plots of closure versus time. Closure rate data are calculated and presented as part of the data analysis. Extensometers provide displacement data from instrumented rods or wires anchored at various depths. Plots show displacement versus time for individual anchors.

Displacement rate data from the hole (collar) to the deepest anchor are presented in the data analysis.

The annual closure rate is calculated as follows:

$$\text{rate}(\text{inches} / \text{year}) = (cfi_2 - cfi_1) / (\text{date}_2 - \text{date}_1) \times 365.25 \text{ days} / \text{year}$$

where cfi = the change from the initial reading (inches)

cfi_1 = cfi reading closest to the beginning of the reporting period

cfi_2 = cfi reading closest to the end of the reporting period

Comparisons between closure rates of the previous and current reporting periods are presented as percent changes in rate and are calculated as follows:

$$\text{percent change in rate} = (\text{Rate}_{\text{Current Period}} - \text{Rate}_{\text{Previous Period}}) / (\text{Rate}_{\text{Previous Period}}) \times 100\%$$

Rock bolt load cells are used to determine bolt support performance. Plots show load versus time for each instrumented bolt.

Earth pressure cells and strain gauges are used to determine the stresses and deformation in and around the shaft liners. Data are depicted in time-based plots.

Piezometers are used to measure the gauge pressure of groundwater and are installed in the shafts at varying elevations to monitor the hydraulic head acting on the shaft liners. Data are plotted as pressure versus time.

Joint meters, installed perpendicular to a crack, monitor the dilation of the crack with time. Data are presented as displacement versus time.

1.4.4 Data Errors

GIS data are processed through a comprehensive database management system. Whether acquired manually or remotely, GIS data are processed and permanently stored according to approved procedures. On occasion, erroneous readings can occur. There are several possible explanations for erroneous readings, including the following:

- The measuring device was misread.
- The reading was recorded incorrectly.
- The measuring device was not functioning within specifications.

When a reading is believed to be erroneous, the suspect reading is evaluated, and, if necessary, a second reading is collected. If the second reading falls in line with the instrument trend, the first reading is discarded and the second reading is entered in the database. If the second reading and subsequent readings remain out of the instrument trend, the ground conditions in the vicinity of the instrument are assessed to determine the reason for the discrepancy. In addition, the reading frequency may be increased.

2.0 GEOLOGY

This chapter provides a summary of the stratigraphy of the WIPP region and the site. Readers desiring further geologic information may consult the "Geological Characterization Report, WIPP Site, Southeastern New Mexico" (Powers et al., 1978). This report was developed as a source document on the geology of the WIPP site for individuals, groups, or agencies seeking basic information on geologic history, hydrology, geochemistry, or detailed information, such as physical and chemical properties of repository rocks. A more recent survey of WIPP stratigraphy is included in Holt and Powers (1990).

2.1 Regional Stratigraphy

The stratigraphy in the vicinity of the WIPP site includes rocks of Permian (295 to 250 million years [Ma] before present [bp]), Triassic (250 to 203 Ma), and Quaternary (1.75 Ma to present) ages. The descriptions of formations provided in this section are given in order of deposition (oldest to youngest), beginning with the Castile Formation (Figure 2-1).

2.1.1 Permian

The Permian system in southwestern North America is divided into four series. The last of these, the Ochoan Series, contains the host rock in which the WIPP repository is located.

The Ochoan Series is of mostly marine origin and consists of four formations: three evaporite formations (the Castile, the Salado, and the Rustler) and one redbeds formation (the Dewey Lake). The Ochoan evaporites overlie marine limestones and sandstones of the Guadalupian Series (Delaware Mountain Group). The younger redbeds represent a transition from the lower evaporite deposition to fluvial deposition on a broad, low-relief, fluvial plain. The Permian rocks are overlain by fluvial deposits of the Triassic and Quaternary periods.

2.1.1.1 Castile Formation

The Castile Formation, lowermost of the four Ochoan formations, is approximately 1,250 ft (380 m) thick in the WIPP vicinity. Lithologically, the Castile is the least complex of the evaporite formations and is composed chiefly of interbedded anhydrite and halite, with limestone present in minor amounts.

2.1.1.2 Salado Formation

The Salado Formation comprises nearly 2,000 ft (610 m) of evaporites, primarily halite. The formation is subdivided into three informal members: the unnamed lower member, the McNutt potash zone, and the unnamed upper member. Each member contains similar amounts of halite, anhydrite, and polyhalite and is differentiated on the basis of soluble potassium- and magnesium-bearing minerals. The WIPP disposal horizon is located within the unnamed lower member, 2,150 ft (655 m) below the surface.

2.1.1.3 Rustler Formation

The Rustler Formation is subdivided into five members, starting from its base: the Los Medaños Member, the Culebra Dolomite Member, the Tamarisk Member, the Magenta Dolomite Member, and the Forty-niner Member.

In the vicinity of the WIPP site, the Rustler is approximately 310 ft (95 m) thick and thickens to the east. The lower portion (Los Medaños Member) contains primarily fine sandstone to mudstone with lesser amounts of anhydrite, polyhalite, and halite. Bedded and burrowed siliciclastic sedimentary rocks with cross-bedding and fossil remains signify the transition from the strongly evaporitic environments of the Salado to the brackish lagoonal environments of the Rustler (Holt and Powers, 1990).

The upper portion of the Rustler contains interbeds of anhydrite, dolomite, and mudstone. The Culebra Dolomite member is generally brown, finely crystalline, and locally argillaceous. The Culebra contains rare to abundant vugs with variable gypsum and anhydrite filling and is the most transmissive hydrologic unit within the Rustler. The Tamarisk Member consists of lower and upper sulfate units separated by a unit that varies laterally from mudstone to mainly halite. The Magenta Dolomite Member is a gypsiferous dolomite with abundant primary sedimentary structures and well-developed

algal features. The Forty-niner Member consists of lower and upper sulfate units separated by a mudstone that displays sedimentary features and bedding. East of the site area, halite correlates with the mudstone. The Culebra and Magenta Dolomite members are persistent and serve as important marker units.

2.1.1.4 Dewey Lake Redbeds

The Dewey Lake Redbeds is the uppermost of the Ochoan Series formations. Within the series, the Dewey Lake represents a transition from the lower marine evaporite deposition to fluvial deposition on a broad, low-relief, fluvial plain. The redbeds, approximately 475 ft (145 m) thick, consist of predominantly reddish-brown interbedded fine-grained sandstone, siltstone, and claystone. This formation is differentiated from others by its lithology and distinctive color (both of which are remarkably uniform), and by sedimentary structures, including horizontal- and cross-laminae and ripple marks. The redbeds also contain locally abundant greenish-gray reduction spots and gypsum filled fractures. The formation thickens from west to east due to eastward dips and erosion to the west.

2.1.2 Triassic

The only Triassic rocks present in the WIPP region belong to the Dockum Group.

2.1.2.1 Dockum Group

The Dockum Group consists of fine-grained floodplain sediments and coarse alluvial debris of Triassic age. From a pinch-out near the center of the WIPP site it thickens eastward, forming an erosional wedge. Local subdivisions of the Dockum Group are the Santa Rosa Sandstone and the Chinle Formation; however, only the Santa Rosa occurs in the vicinity of the site. It consists primarily of poorly sorted sandstone with conglomerate lenses and thin mudstone partings and contains impressions and remnants of fossils. These rocks have more variegated hues than the underlying uniformly colored Dewey Lake.

2.1.3 Quaternary

Quaternary Period deposits include the Gatuña Formation, Mescalero Caliche, and surficial sediments.

2.1.3.1 Gatuña Formation, Mescalero Caliche, and Surficial Sediments

The Gatuña Formation (ranging in age from approximately 1.3 million to 600,000 years bp) (Powers and Holt, 1993) is a stream-laid deposit overlying the Dockum Group in the WIPP vicinity. At the site center, the formation consists of approximately 13 ft (4 m) of poorly consolidated sand, gravel, and silty clay. The Gatuña Formation is light red and mottled with dark stains. The unit contains abundant calcium carbonate, but is poorly cemented. Sedimentary structures are abundant (Powers and Holt, 1993, 1995).

The Mescalero Caliche (approximately 500,000 years bp) is approximately 4 ft (1.2 m) thick in the WIPP vicinity. The Mescalero is a hard, resistant soil horizon that lies beneath a cover of wind-blown sand. The horizon is petrocalcic (i.e., very strongly cemented with calcium carbonate). Petrocalcic horizons form slowly beneath a stable landscape at the average depth of infiltration of soil moisture and indicate stability and integrity of the land surface. Many of the surface buildings at WIPP are founded on top of the Mescalero Caliche.

Surficial sediments include sandy soils developed from eolian material and active dune areas. The Berino Series (a soil type) covers about 50 percent of the site and consists of deep sandy soils that developed from wind-worked material of mixed origin. Based on sample analyses, the Berino soil from the WIPP site formed $330,000 \pm 75,000$ years bp.

**Geotechnical Analysis Report for July 2012 – June 2013
DOE/WIPP-14-3516, Vol. 1**

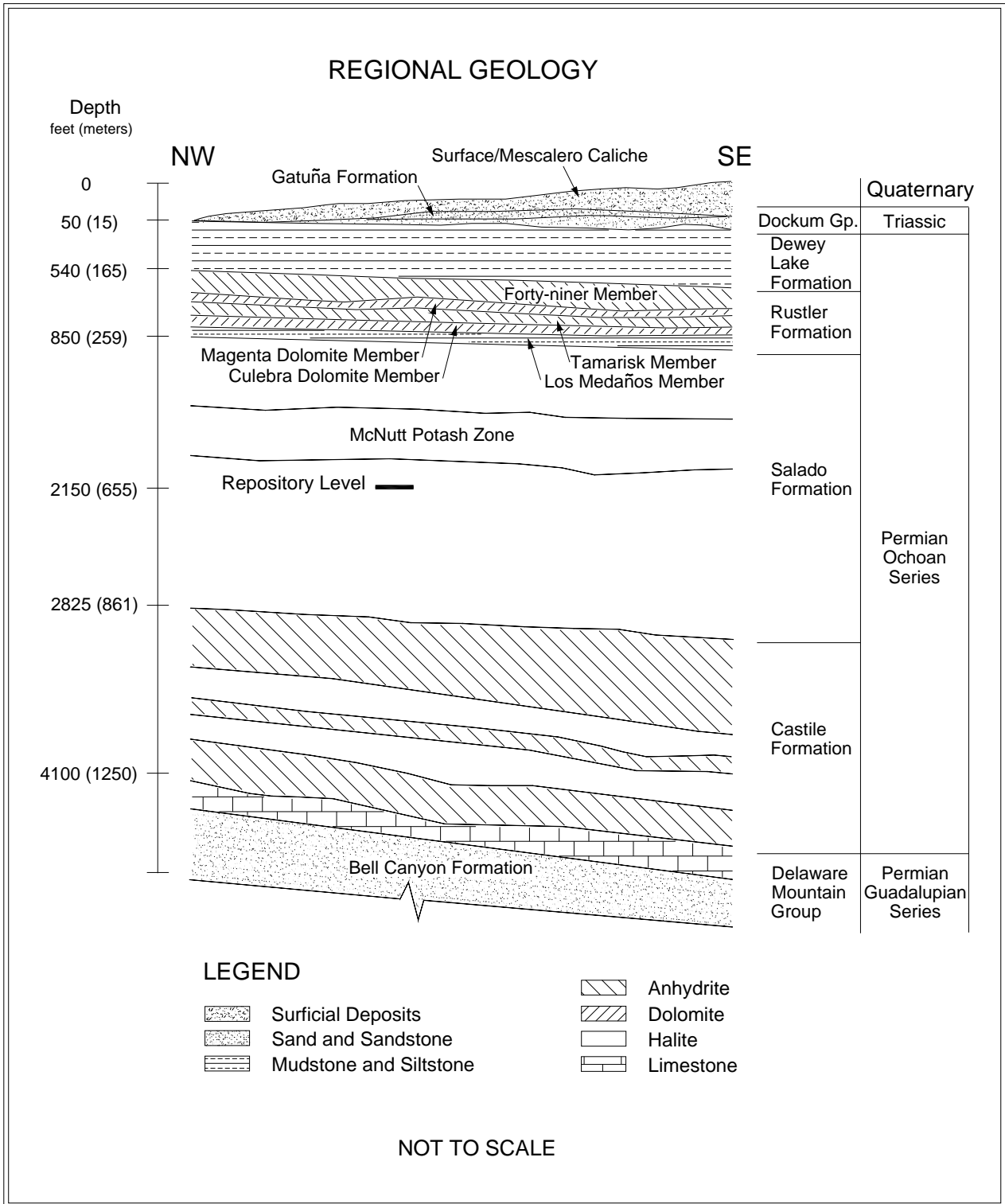

Figure 2 - 1 Regional Geology

2.2 Underground Facility Stratigraphy

The WIPP disposal horizon lies near the midpoint of the Salado Formation. The Salado was deposited in a shallow saline lagoon environment, which progressed through numerous inundation and desiccation cycles that are reflected in the formation. An "ideal" cycle progresses upward as follows: a basal layer consisting predominantly of claystone, followed by a layer of sulfate, which is in turn followed by a layer of halite. The entire sequence is capped by a bed of argillaceous (clay-rich) halite accumulated during a period of mainly subaerial exposure.

A regional system used for numbering the more significant sulfate beds within the Salado designates these beds as marker beds (MBs), counted from MB100 near the top of the formation to MB144 near the base. The repository is located between MB138 and MB139 within a sequence of laterally continuous depositional cycles as described above. Within this sequence, layers of clay and anhydrite that are locally designated (as shown) can have a significant impact on the geomechanical performance of the excavations. Clay layers provide surfaces along which slip and separation can occur, whereas anhydrites form brittle layers that do not deform plastically.

In the vicinity of WIPP, the stratigraphy is fairly continuous and uniform. Beds generally dip toward the south-southeast at a slope of approximately 3 percent.

2.2.1 Disposal Horizon Stratigraphy of Panels 1, 2, 7, and 8

This disposal horizon contains Panels 1, 2, 7, and 8, all the shaft areas, the shop areas, the SPDV areas (which are now closed), and all the access drifts north of S-2620. Farther south, the four main entries rise in a ramp that starts at S-2620 and ends at S-2740. Panel 7 excavation was completed in January of 2013. Panel 8 has not yet been excavated.

Most underground excavations are located within this disposal horizon (Figure 2-2). In it, the Orange Marker Bed (OMB) lies near the middle of the rib (i.e., the excavation wall). The OMB is a laterally consistent unit of moderate to light reddish-orange translucent halite about 6 inches (in) (15 centimeters [cm]) thick that is used as a point of reference during excavation.

MB139 lies approximately 11.5 ft (3.5 m) below the OMB. MB139 is a 20 to 32 in (50 to-80 cm) thick layer of polyhalitic anhydrite. The top of the anhydrite undulates up to 15 in (38 cm), while the bottom is sub-horizontal and is underlain by Clay E.

Above MB139 is a unit of halite that terminates at the base of the OMB. Within this unit, polyhalite is locally abundant and decreases upward, while argillaceous material increases upward.

Geotechnical Analysis Report for July 2012 – June 2013
DOE/WIPP-14-3516, Vol. 1

Above the OMB, a thin band of argillaceous halite gives way to a thick sequence of clear halite that becomes increasingly argillaceous upward and is capped by Clay F. This constitutes a thin layer occasionally interrupted by partings and breaks and is readily visible in the upper ribs. Above Clay F, another sequence of halite begins that, as in lower sequences, becomes increasingly argillaceous upward. This sequence terminates at the Clay G/Anhydrite "b" interface, approximately 6.5 ft (2 m) above the roof of most disposal horizon excavations, forming a roof beam that typically acts as a structural unit.

The roof of some disposal horizon excavations (e.g., the E-140 drift between S-1000 and S-1950), has been excavated to the upper contact of Anhydrite "b." In this case, a roof beam is formed by the next depositional sequence beginning with Anhydrite "b" and progressing upward to the Clay H/Anhydrite "a" interface, approximately 6.5 ft (2 m) above the upper contact of Anhydrite "b."

Geotechnical Analysis Report for July 2012 – June 2013
DOE/WIPP-14-3516, Vol. 1

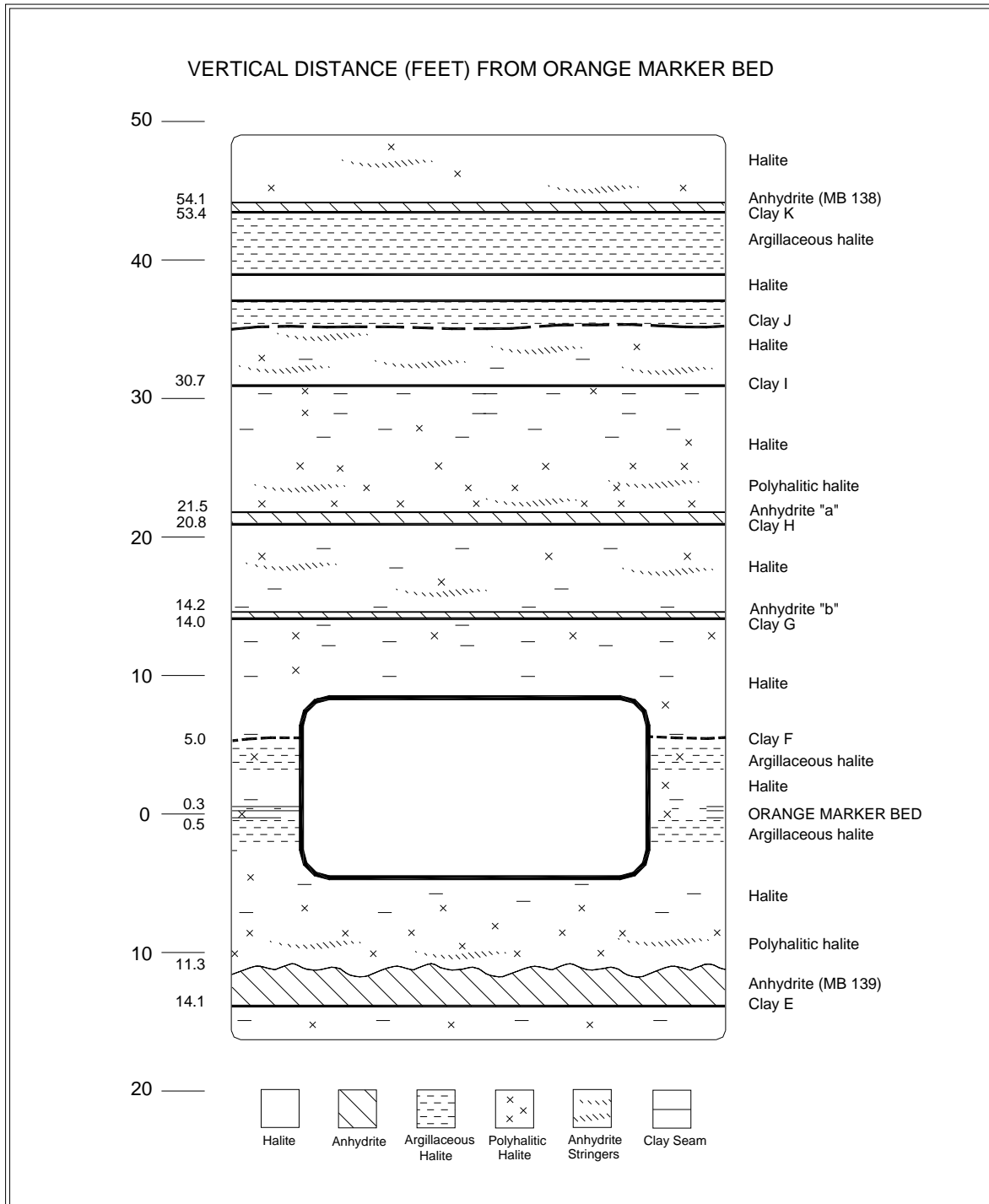

Figure 2 - 2 Repository Level Stratigraphy of Panels 1, 2, 7, and 8

2.2.2 Disposal Horizon Stratigraphy of Panels 3, 4, 5, and 6

Field observations and computer modeling indicated that moving the disposal horizon stratigraphically upward (so that the roof was located at Clay G) would improve long term ground conditions and provide a more stable roof configuration without significantly impacting repository performance. In 2000, the decision was made to implement this change by moving the mining horizon up approximately six feet. Subsequently, in 2000 and 2001, ramps were mined in the W-170, W-30, E-140, and E 300 drifts between S-2620 and S-2750 (Figure 1-2). As a result, the disposal horizon for Panels 3, 4, 5, and 6, and the associated connecting drifts lies above the horizon for the other panels (Figure 2-3).

In this horizon, the OMB lies at or below the floor. MB139 lies about 12 ft (3.7 m) below the floor. The roof lies at or slightly above Anhydrite "b." Clay G/ Anhydrite "b" is used as the mining reference during excavation of this disposal horizon. Locally continuous anhydrite stringers are found within this beam, generally concentrated in the lower portion toward Anhydrite "b". These effectively divide the roof beam itself into a series of thinner, independent beams.

2.2.3 Northeast Area Stratigraphy

All of the Northeast Area, a former experimental area, is now deactivated and closed to access. These excavations lie at a higher stratigraphic level than the disposal excavations. Floors are at Anhydrite "b." As in the lower units, the halite intervals between the clay seams/anhydrite beds contain relatively pure halite that becomes increasingly argillaceous upward. Above clay I, two more halite intervals complete the underground facility stratigraphy. Clay J, at the top of the first of these intervals, may consist of a distinct seam or merely an argillaceous zone. Clay K tops the second interval and is overlain by MB138.

**Geotechnical Analysis Report for July 2012 – June 2013
DOE/WIPP-14-3516, Vol. 1**

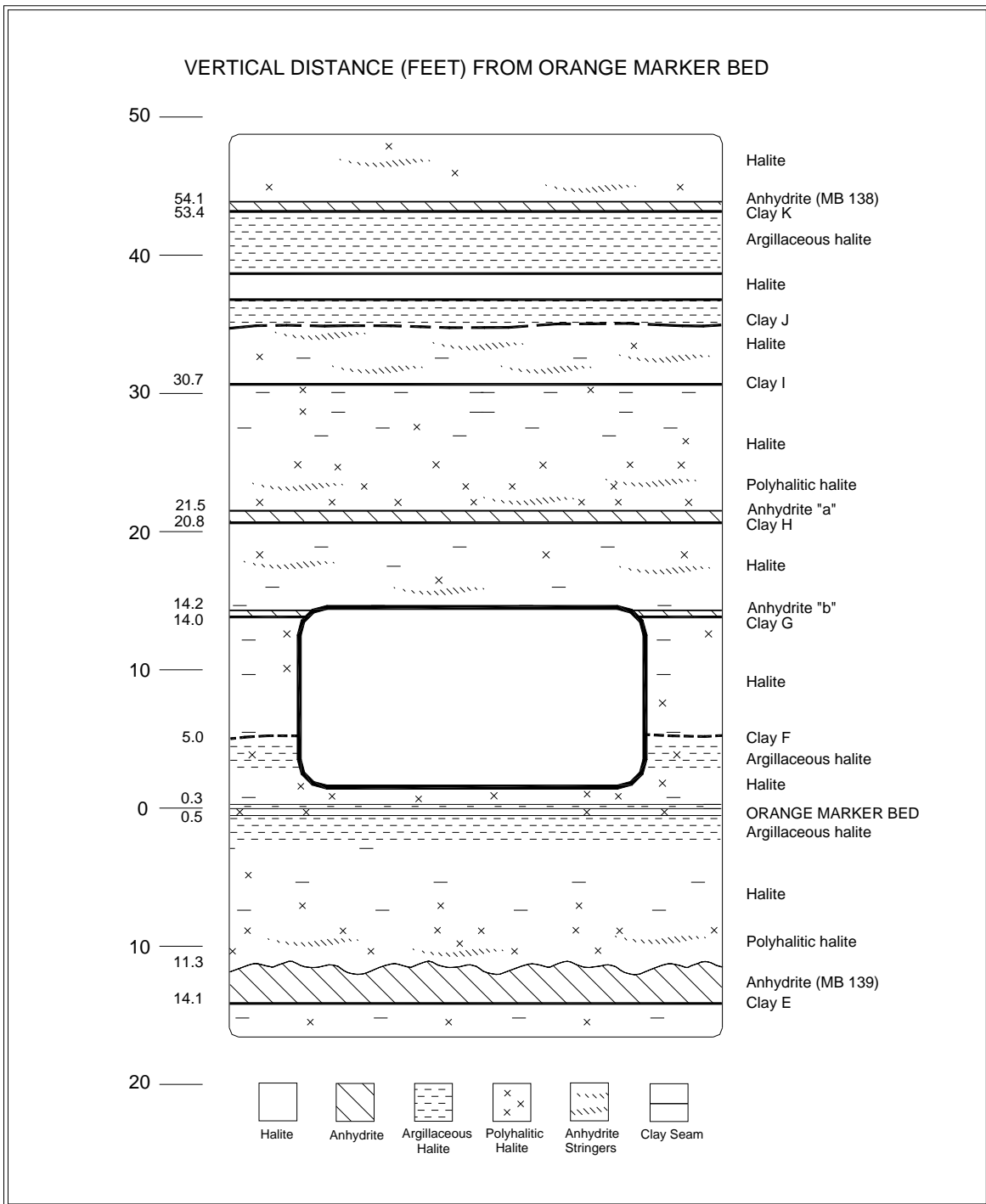

Figure 2 - 3 Repository Level Stratigraphy of Panels 3, 4, 5, and 6

3.0 PERFORMANCE OF SHAFTS AND KEYS

Four shafts connect the surface with the underground. They are the Salt Shaft, which is used primarily for removing excavated salt from the underground and for transporting personnel and material; the Waste Shaft, which is used primarily for transporting TRU waste to the underground and for transporting personnel and materials; the Exhaust Shaft, which is used to exhaust the ventilation air from the underground; and the Air Intake Shaft, which is the primary source of fresh air ventilation to the underground. This chapter describes the geomechanical performance of these shafts.

Although through the years much of the instrumentation installed in the shafts has failed, there are no plans to replace it. The project has a good understanding of the expected movements in the shafts. Monitoring results up to the point of instrument failure did not indicate unusual shaft movements or displacements. Continued periodic visual inspections confirm the expected shaft performance and provide necessary observations to evaluate shaft performance. Replacement of failed instrumentation will not provide significant additional information.

3.1 Salt Shaft

The first construction activity undertaken during the SPDV Program was the excavation of the Exploratory Shaft. This shaft was subsequently referred to as the Construction and Salt Shaft and is currently designated the Salt Shaft (see Figure 1-2). The shaft was drilled from July 4 to October 24, 1981, and geologically mapped in the spring of 1982 (DOE, 1983). Figure 3-1 presents the stratigraphy in the shaft.

The Salt Shaft is lined from the surface to 846 ft (258 m) with steel casing having an inside diameter of 10 ft (3-m). The thickness of the steel liner (including external stiffener rings) increases from 0.62 in (1.6 cm) at the top to 1.5 in (3.8 cm) at the key. Cement grout was placed between the liner and the rock face. The 10-ft (3-m) diameter extends through the concrete shaft key to 880 ft (268 m). The shaft key is a 37.5 ft (11.4-m) long, reinforced-concrete structure that begins 3.5 ft (1.07 m) above the bottom of the steel liner. From the key to the bottom at 2,298 ft (700 m), the shaft has a nominal diameter of 12 ft (4 m).

Wire mesh anchored by rock bolts is installed in sections of the lower shaft as a safety screen to contain rock fragments that may become detached. The shaft extends approximately 140 ft (43 m) below the repository horizon in order to accommodate the skip loading equipment and a sump.

**Geotechnical Analysis Report for July 2012 – June 2013
DOE/WIPP-14-3516, Vol. 1**

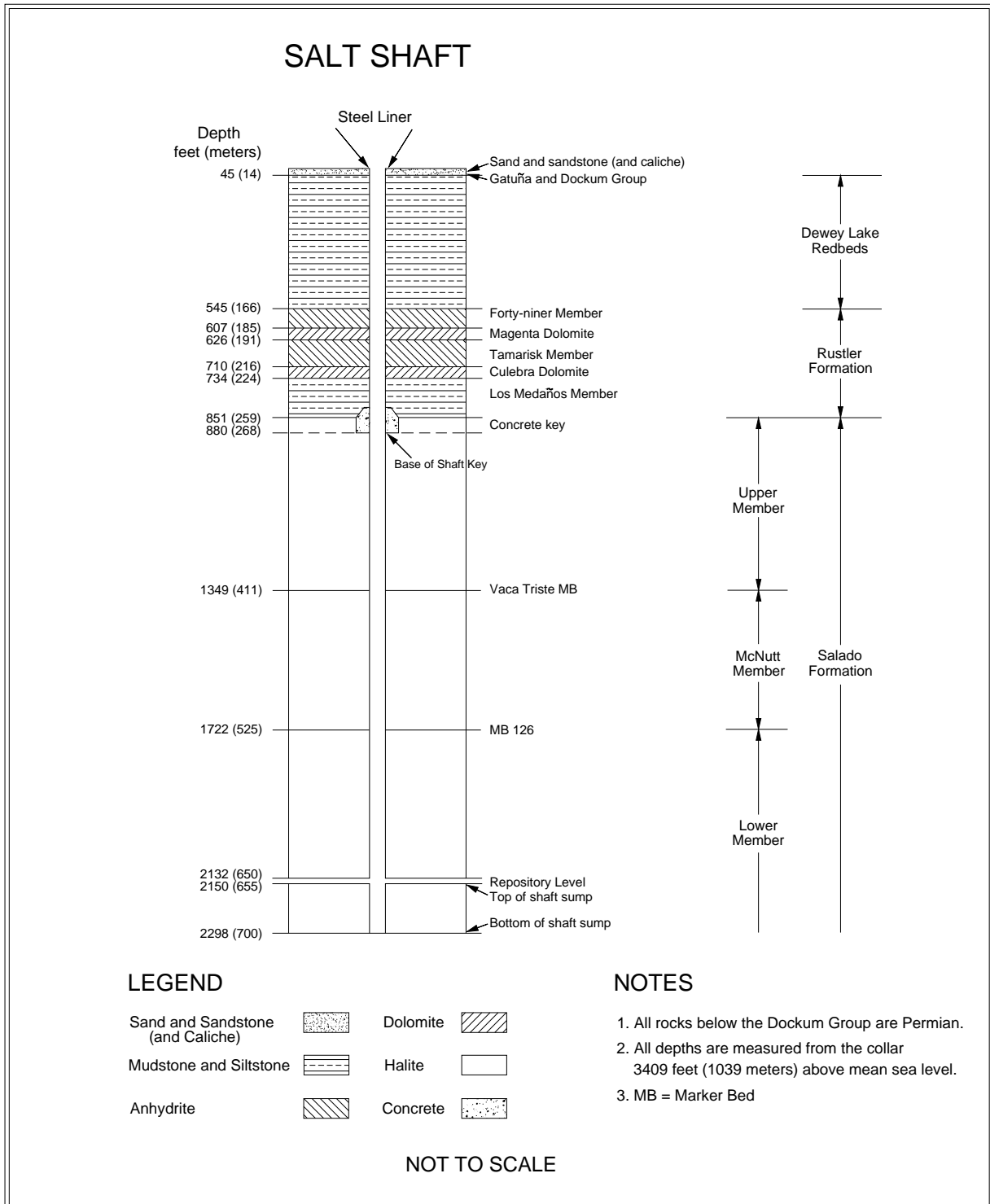

Figure 3 - 1 Salt Shaft Stratigraphy

3.1.1 Shaft Observations

Underground operations personnel conduct weekly visual inspections. These inspections are performed principally to assess the condition of the hoisting and mechanical systems, but they also include examining the shaft walls for water seepage, loose rock, or sloughing. Visual inspections during this reporting period found that the shaft remained in satisfactory condition. Only routine ground control activities were required.

3.1.2 Instrumentation

Geomechanical instruments (radial convergence points, extensometers, and piezometers) were installed at various levels in the shaft from April through July of 1982 (Figures 3-2 and 3-3). In the shaft key, instruments included strain gauges, pressure cells, and piezometers. Radial convergence points were installed prior to outfitting. Upon completion of shaft outfitting, no more readings were taken.

Ten of the 12 piezometers continue to provide data. The fluid pressures recorded at the end of this reporting period range from approximately 62 pounds per square inch (psi) (427 kilopascals [kPa]) at the 802-ft (244-m) level in the Los Medaños Member to 199 psi (1372 kPa) at the 691-ft (211-m) level in the Tamarisk Member. The recorded pressures for this reporting period are generally consistent with the readings from the previous reporting period. The fluid pressure on the shaft liner will continue to be monitored on a regular basis.

Four earth pressure cells were installed in the key section during concrete emplacement at the 860-ft (262-m) level. These instruments measure the normal stress between the concrete key and the Salado Formation as salt creep loads up the key structure. Three of the four earth pressure cells continue to provide data. These instruments have indicated essentially no contact pressure since their installation (readings resemble instrument drift at a zero pressure). The maximum contact pressure recorded by the instruments for this reporting period is 6 psi (41 kPa).

**Geotechnical Analysis Report for July 2012 – June 2013
DOE/WIPP-14-3516, Vol. 1**

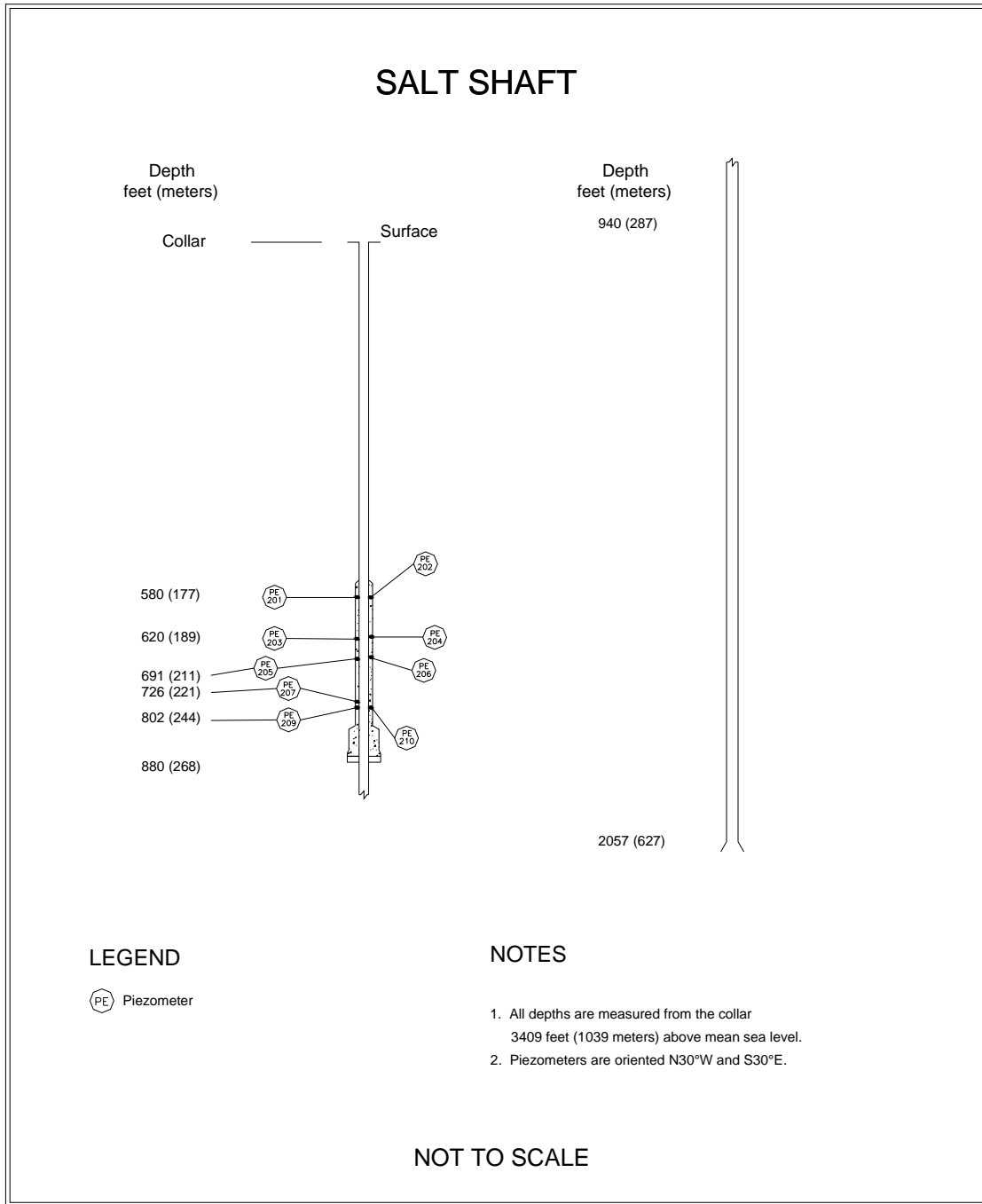

Figure 3 - 2 Salt Shaft Instrumentation (Without Shaft Key)

**Geotechnical Analysis Report for July 2012 – June 2013
DOE/WIPP-14-3516, Vol. 1**

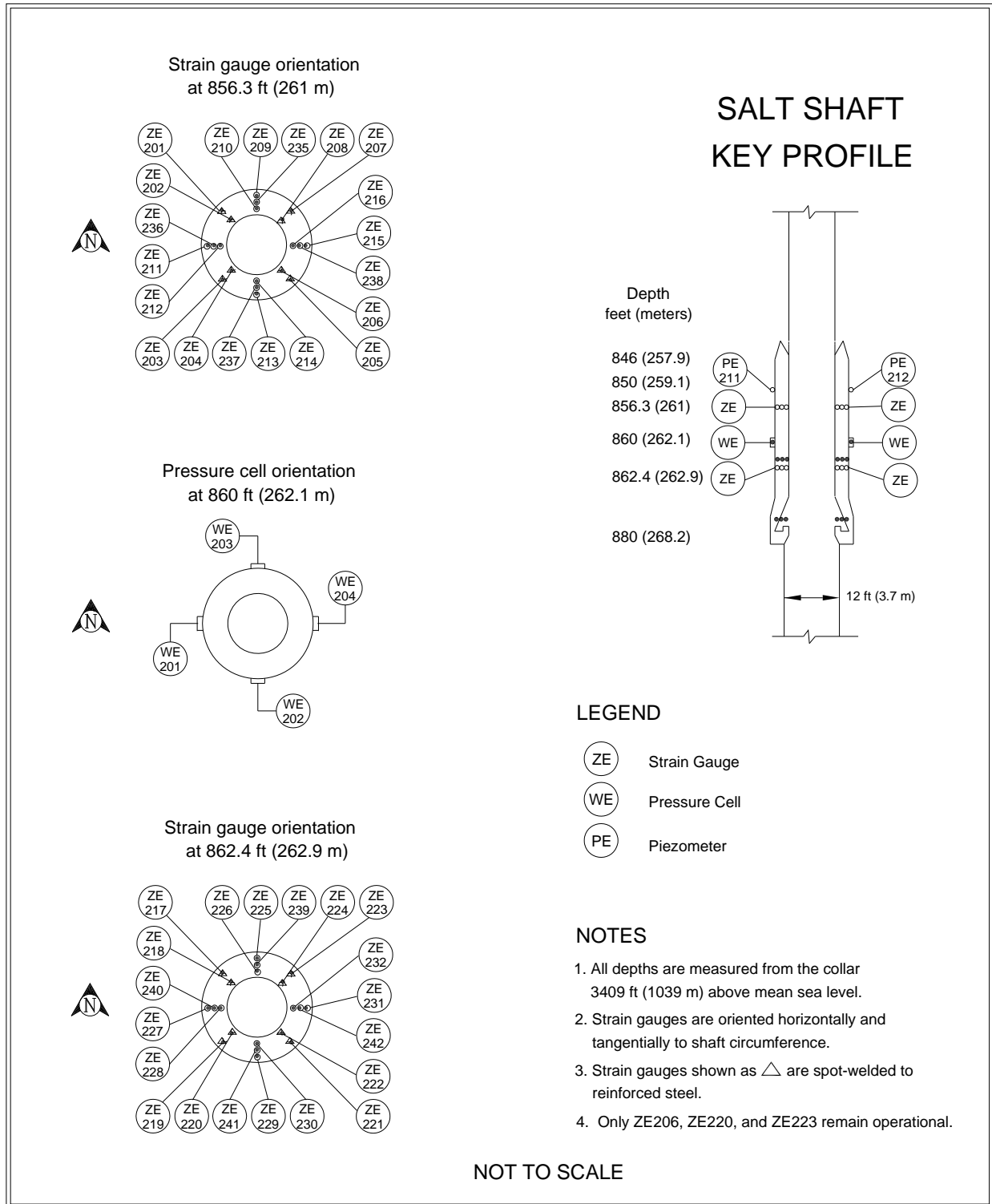

Figure 3 - 3 Salt Shaft Key Instrumentation

Geotechnical Analysis Report for July 2012 – June 2013
DOE/WIPP-14-3516, Vol. 1

Sixteen spot-welded and twenty-four embedment strain gauges were installed on and in the shaft key concrete at both the 856.3-ft (261-m) level and at the 862.4-ft (263-m) level. Three spot-welded strain gauges are still functioning at these levels. Strain at the 856.3-ft (261-m) level recorded a maximum strain of 686 microstrain. Strains at the 862.4 ft (263 m) level were 714 and 956 microstrain.

Fourteen embedment strain gauges are still functioning. The strains at the 856.3-ft (261-m) level ranged from -858 to 1030 microstrain. The strains from the two embedment strain gauges at the 862.4 ft (263-m) level were 575 to 429 microstrain. The strains recorded by the spot-welded strain gauges and the embedment strain gauges during this reporting period are largely similar to the strains recorded by these instruments at the end of the previous reporting period.

3.2 Waste Shaft

As part of the SPDV Program, a 6-ft (2-m) diameter ventilation shaft, now referred to as the Waste Shaft, was excavated from December 1981 through February 1982 (see Figure 1-2). This shaft, in combination with the Salt Shaft, provided a two-shaft underground air circulation system. From October 11, 1983, to June 11, 1984, the shaft was enlarged to a diameter of 20 to 23 ft (6 to 7 m) and lined above the key. Stratigraphic mapping (Figure 3-4) was conducted during shaft enlargement from December 9, 1983, to June 5, 1984 (Holt and Powers, 1984).

The Waste Shaft is lined with non-reinforced concrete having a 19 ft (6 m) inside diameter from the surface to the top of the key at 837 ft (255 m). Liner thickness increases from 10 in (25 cm) at the surface to 20 in (51 cm) at the key. The key is 63 ft (19 m) long and 4.25 ft (1.3 m) thick and is constructed of reinforced concrete. The bottom of the key is 900 ft (274 m) below the surface. The diameter of the shaft is 20 ft (6 m) at the bottom of the key and increases to 23 ft (7 m) just above the shaft station. The shaft below the key is lined with wire mesh anchored by rock bolts. The diameter of 23 ft (7 m) extends to a depth of approximately 2,286 ft (697 m), with the shaft sump comprising the lower 119 ft (36 m) of that interval.

**Geotechnical Analysis Report for July 2012 – June 2013
DOE/WIPP-14-3516, Vol. 1**

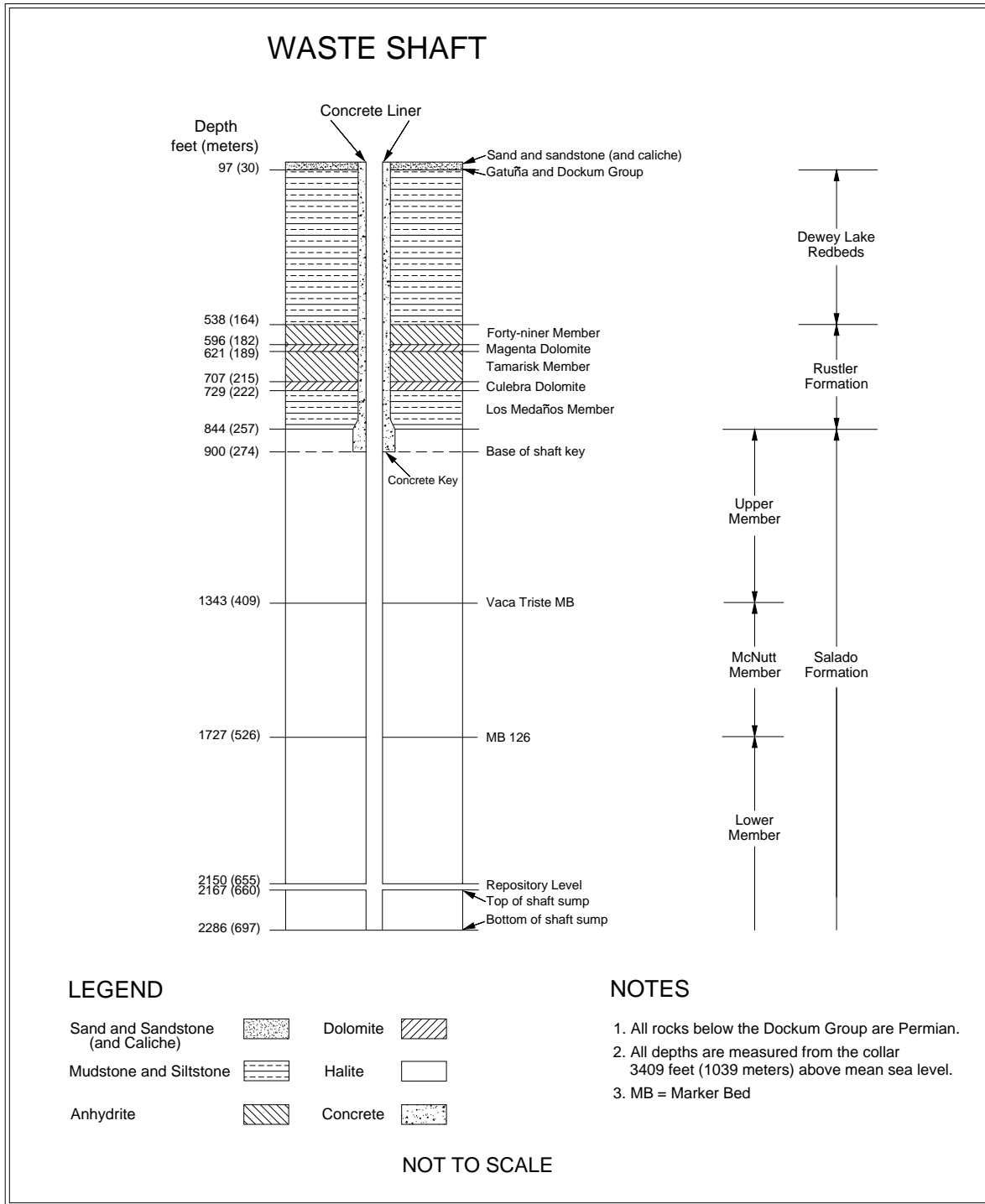

Figure 3 - 4 Waste Shaft Stratigraphy

3.2.1 Shaft Observations

Underground operations personnel conduct weekly visual inspections, principally to assess the condition of the hoisting and mechanical systems, but also include observation of the shaft walls for water seepage, loose rock, or sloughing. The visual inspections found that the shaft was in satisfactory condition. No ground control activities other than routine maintenance were required.

3.2.2 Instrumentation

Radial convergence points, extensometers, piezometers, and earth pressure cells were installed in the Waste Shaft between August 27 and September 10, 1984. Radial convergence points were installed prior to the outfitting. Upon completion of shaft outfitting, no more radial convergence readings were taken. Figure 3-5 and Figure 3-6 show the instrument locations.

Nine multi-position extensometers were installed in arrays 1,071 ft (326 m), 1,566 ft (477 m), and 2,059 ft (628 m) below the surface as shown in Figure 3-5. Each array consists of three extensometers. No extensometer data have been collected in recent years due to the malfunction of the data acquisition equipment. Since the type of extensometers installed in the shaft over 29 years ago is no longer manufactured, remote data acquisition equipment for these extensometers is also unavailable.

Twelve piezometers were installed in the lined section of the Waste Shaft on September 7 and 8, 1984, to monitor fluid pressure behind the shaft liner and the key section. As of this reporting period, data is no longer being received from any of the piezometers.

Four earth pressure cells were installed in the key section of the Waste Shaft during concrete emplacement between March 23 and April 3, 1984. Earth pressure cells measure the normal stress between the concrete key and the Salado Formation as salt creep loads the key structure. As of this reporting period, data is no longer being received from any of the earth pressure cells.

**Geotechnical Analysis Report for July 2012 – June 2013
DOE/WIPP-14-3516, Vol. 1**

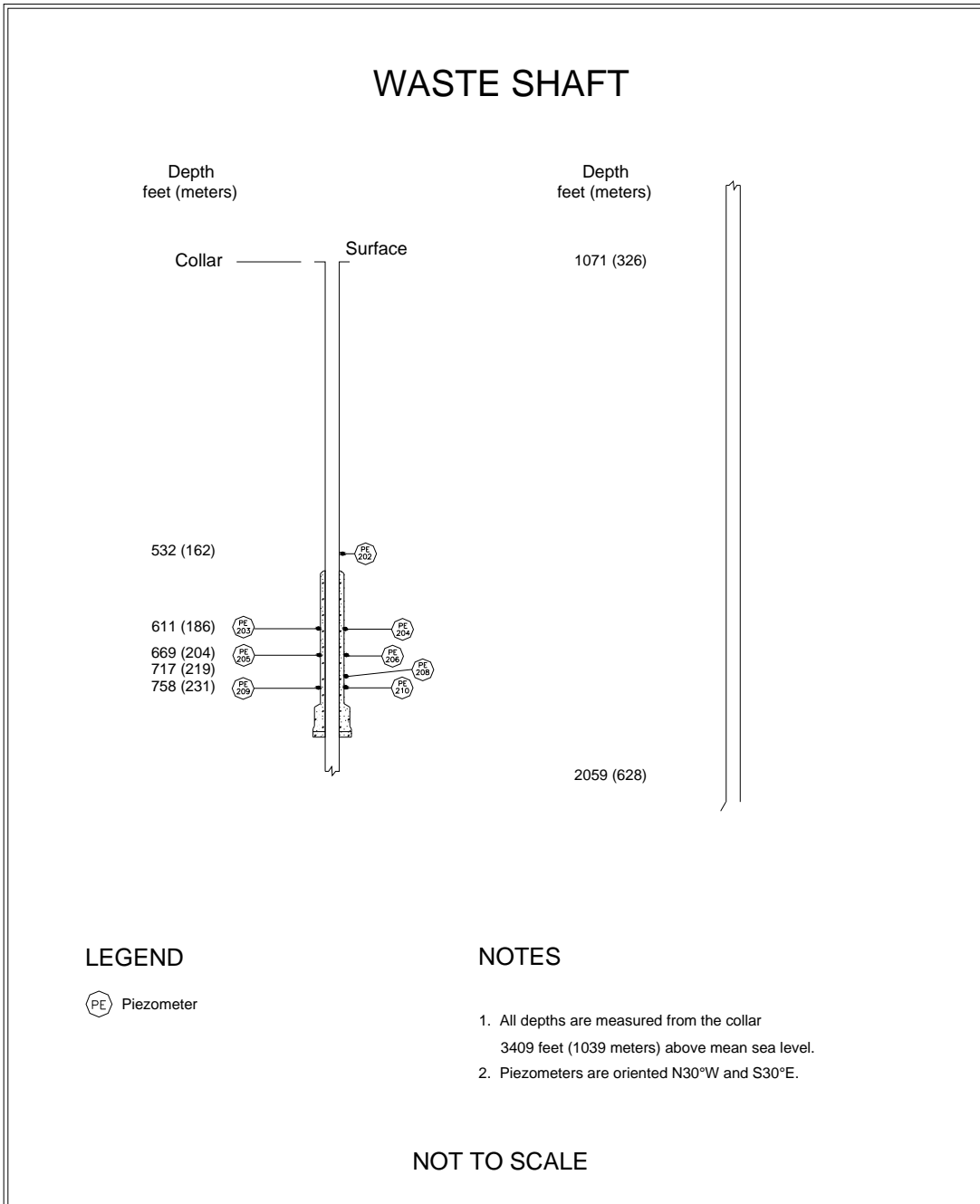

Figure 3 - 5 Waste Shaft Instrumentation (Without Shaft Key)

**Geotechnical Analysis Report for July 2012 – June 2013
DOE/WIPP-14-3516, Vol. 1**

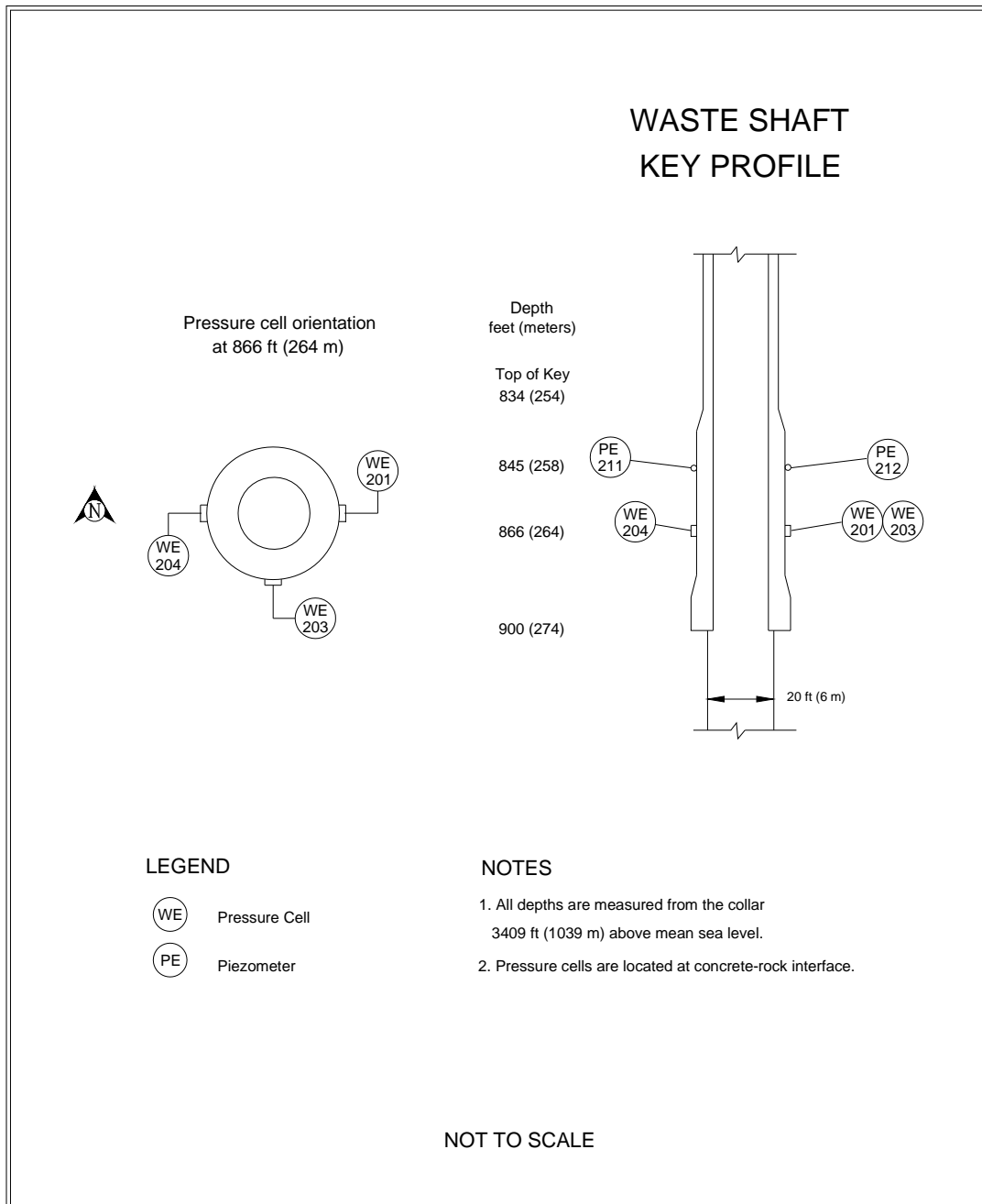

Figure 3 - 6 Waste Shaft Key Instrumentation

3.3 Exhaust Shaft

The Exhaust Shaft was drilled from September 22, 1983, to November 29, 1984, to establish a route from the underground to the surface for exhaust air (Figure 1-2). Stratigraphic mapping was conducted from July 16, 1984, to January 18, 1985 (DOE, 1986c). Figure 3-7 illustrates the shaft stratigraphy.

The Exhaust Shaft is lined with non-reinforced concrete from the surface to the top of the shaft key at 844 ft (257 m). The liner thickness increases from 10 to 16 in (25 to 41 cm) over that interval. The key is 63 ft (19 m) long and 3.5 ft (1 m) thick. The shaft diameter below the key is 15 ft (5 m), and the interval below the key is lined with wire mesh anchored by rock bolts. The shaft terminates at the facility horizon, approximately 2,150 ft (655 m) deep. This shaft has no sump.

3.3.1 Exhaust Shaft Observations

Quarterly video inspections were conducted according to approved WIPP procedures. Inspections were performed to evaluate the condition and to verify the integrity of the shaft. The shaft was examined for cracks, corrosion, salt buildup, seeps, and debris. In addition, inspections examined the condition of anchors, brackets, and down-hole equipment. Between July 2012 and June 2013, four quarterly shaft inspections were conducted on September 13, 2012; November 15, 2012; February 29, 2013; and May 20, 2013.

3.3.1.1 Video Camera

Video inspections use a custom-designed vertical-drop color camera in an aerodynamic housing, suspended by a dual-armored cable, with pan, tilt, and zoom capability. The cable contains five copper conductors and two multi-mode optical fibers. It is reeled out by a winch mounted in a control van. Inspections are recorded electronically.

3.3.1.2 Shaft Inspection Observations

Quarterly video inspection observations concentrate on four major areas: air monitoring components, shaft liner, shaft walls, and equipment support and cabling. The air monitoring components consist of one air-velocity and three air-monitoring devices as shown in Figure 3-8. The video inspection includes examination of each device, including the transport assembly, guide tubes, the sample intake, and the support brackets that extend from Station "A" above the shaft to the shaft collar. Air monitoring components extend from the collar 21 ft into the shaft. Video inspections indicate that the air-sampling components can accumulate salt buildup of up to several inches thick.

The Exhaust Shaft liner is examined for cracks, seepage, and general shaft stability. Currently, there are three principal zones of seepage in the shaft. The first is about 50 to 55 ft below the shaft collar (bsc). The second is about 60 to 65 ft bsc. The third is about 75 to 80 ft bsc, as shown in Figure 3-9. Monitoring of seepage horizons started before 1995. Water entering the shaft through these cracks is believed to originate from a perched aquifer at the base of the Santa Rosa Formation that is being recharged as the result of surface modifications at the site. The fluid level in the Santa Rosa near the shaft is about 46 to 47 ft below the surface. Based on examination of inspection videos, the flow rate into the shaft during this reporting period is estimated at about 1 to

Geotechnical Analysis Report for July 2012 – June 2013
DOE/WIPP-14-3516, Vol. 1

1 ½ gallons per minute, most of which is carried out of the shaft by the exhaust air. Seepage cracks are confined primarily to the eastern side of the shaft wall.

When fluid was detected seeping into the shaft, a catch basin was designed and installed at the base of the Exhaust Shaft to intercept water and prevent it from draining into the Waste Shaft Sump. Fluid was removed from the catch basin from March 1996 through October 2005 as needed. The catch basin was damaged in 2004 by fallen debris, either salt or instrumentation cables or both. A new catch basin was fabricated and installed in December 2004. This basin was damaged in August 2005, most likely the result of fallen debris. An interception well system was installed between November 2005 and March 2006 to replace the catch basin. Interception wells were drilled down gradient in S-400 between E-140 and E 300 (Figure 3-10). The interception well system initially consisted of four 30-ft deep 9-7/8-in diameter fluid collection holes with a submersible pump and pressure transducer in each. Fluid is pumped from each hole to a series of storage containers in S-550. A data-acquisition system monitors the fluid level in each hole, turning the pump on and off between set limits as needed.

Between February 2 and 6, 2008, two additional fluid collection holes, OH631 and OH632, were drilled in S-400 to improve the total volume of fluid recovered by the interception well system. They replaced OH613 and OH614 which generated little fluid. As with the previous four holes, the additional holes were drilled at 9-7/8-inch diameter to a total depth of 30 feet. Pumps were pulled from OH613 and OH614 and installed in OH631 and OH632. Figure 3-10 shows the location of the interception wells system and the 500-gallons storage containers.

**Geotechnical Analysis Report for July 2012 – June 2013
DOE/WIPP-14-3516, Vol. 1**

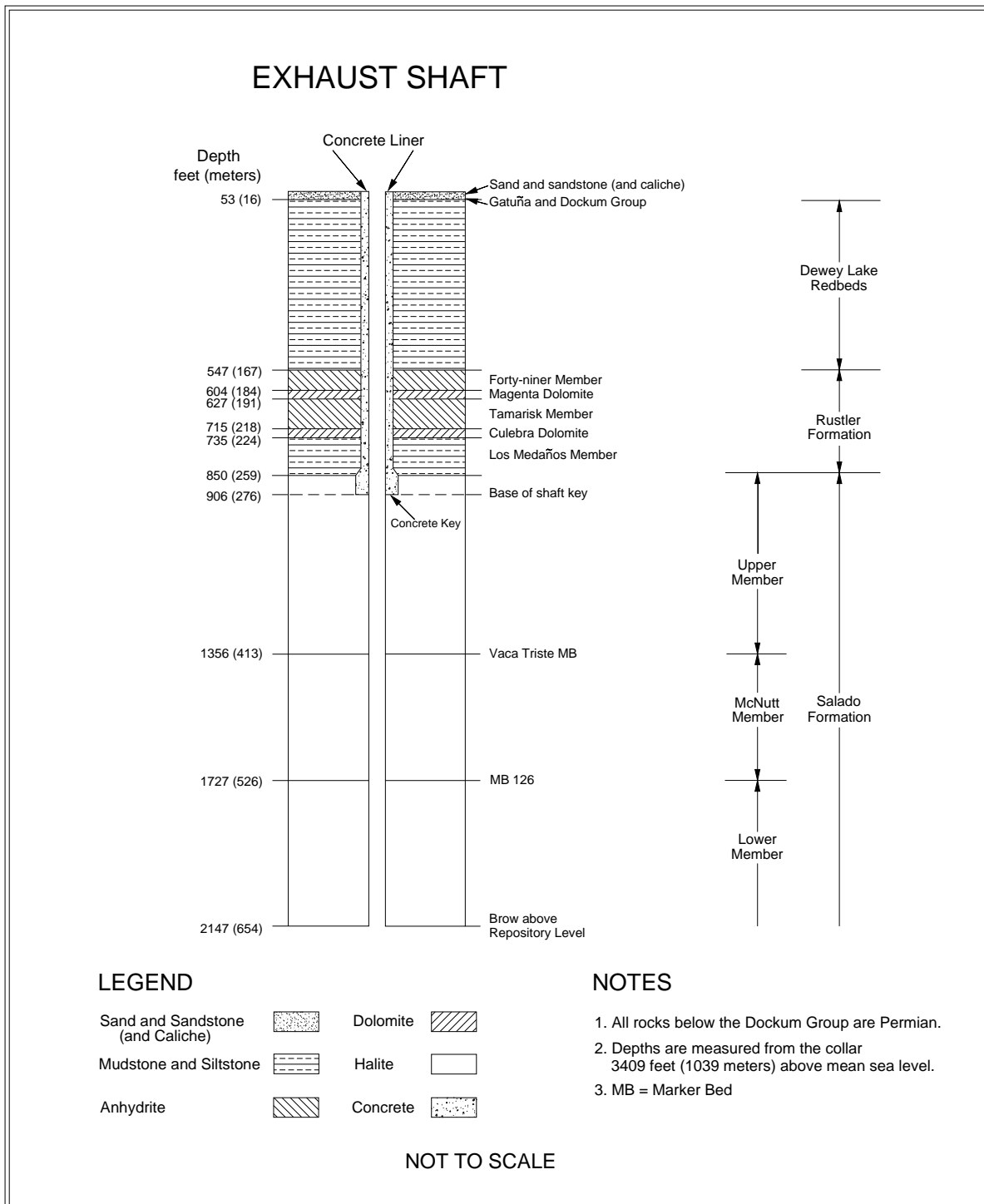

Figure 3 - 7 Exhaust Shaft Stratigraphy

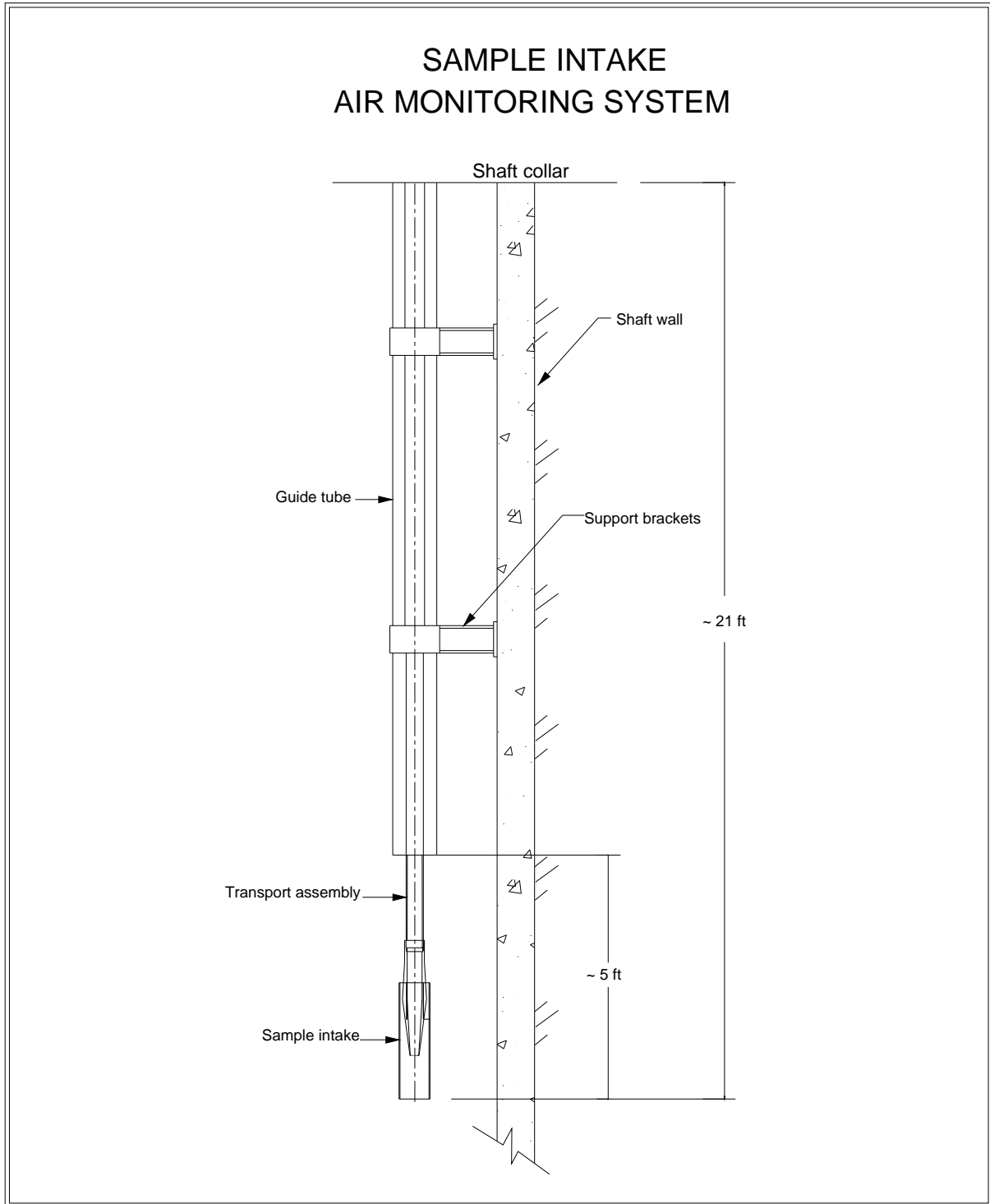

Figure 3 - 8 Sample Intake of Exhaust Shaft Air Monitoring System

**Geotechnical Analysis Report for July 2012 – June 2013
DOE/WIPP-14-3516, Vol. 1**

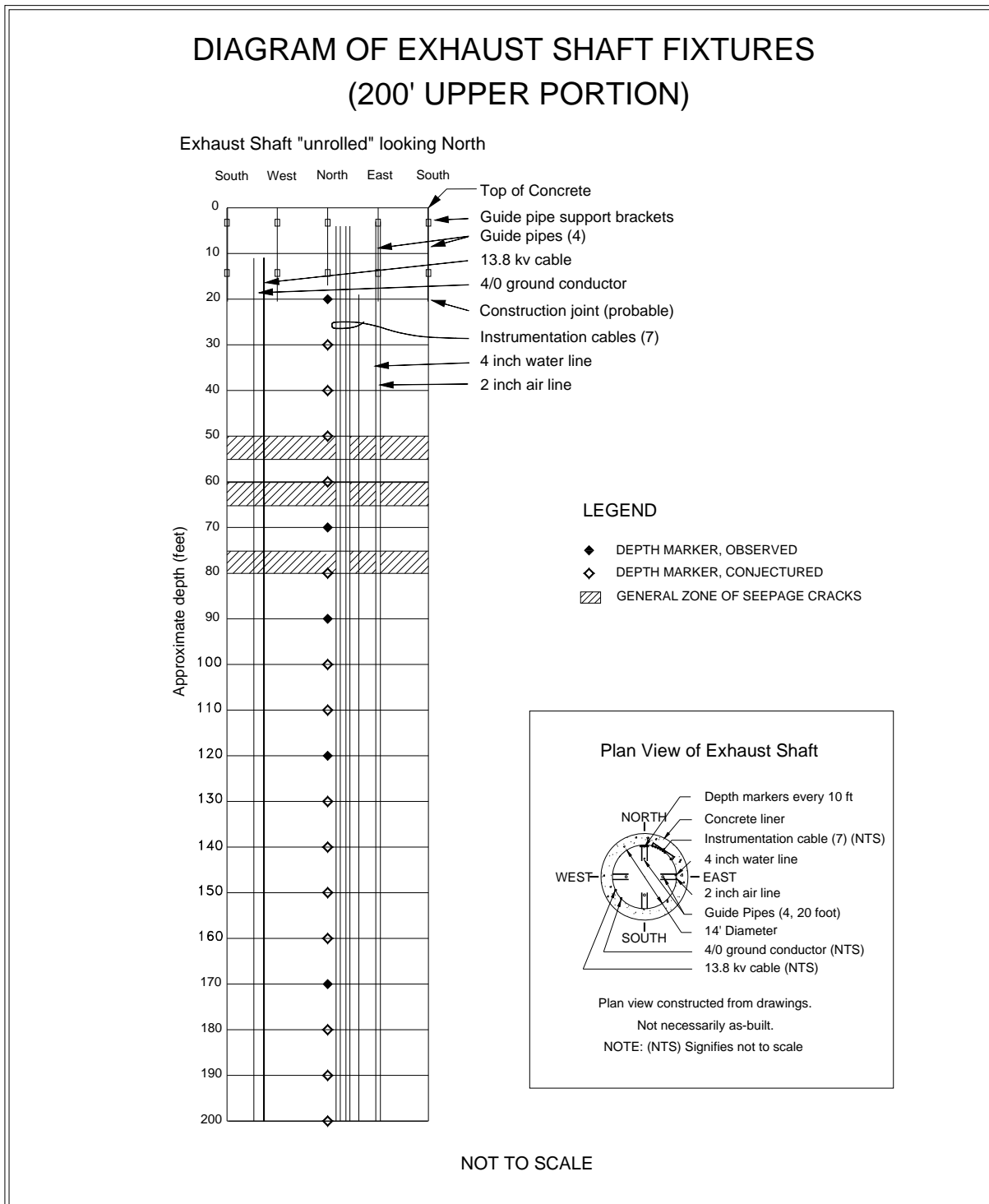

Figure 3 - 9 Diagram of Exhaust Shaft Fixtures and Seepage Zones (Upper 200 ft)

Geotechnical Analysis Report for July 2012 – June 2013
DOE/WIPP-14-3516, Vol. 1

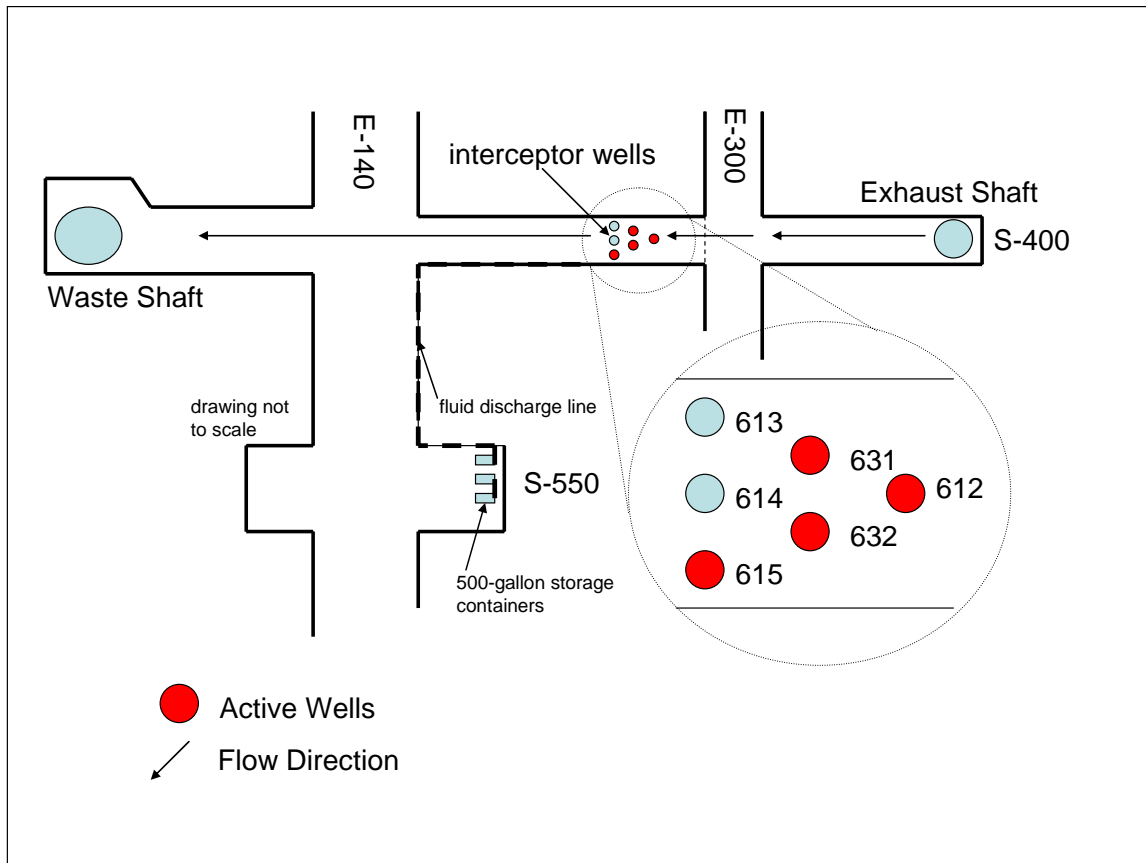

Figure 3 - 1 Location of Interception Wells and Storage Containers

Figure 3-11 presents the volume of fluid removed from the catch basin from July 1997 through June 2006, and by the interception well system from July 2006 through June 2013. The largest reported volumes are typically associated with periods of reduced ventilation and increased humidity. For a discussion of the factors affecting the quantity of fluid produced in the Exhaust Shaft, refer to DOE/WIPP-00-2000, *Brine Generation Study*.

The shaft walls were examined for salt buildup, cracks, moisture, and encrustations, with particular attention paid to power cables, instrument cables, air lines and water-lines, and the three water rings at the base of the Magenta and Culebra members of the Rustler Formation and the bottom of the shaft key. The condition of the shaft wall varies depending on airflow, humidity, temperature, and underground mining activities. During this reporting period, significant mining activity continued in Panel 7 and the Salt Disposal Investigation (SDI) area. The principal areas in the shaft with significant salt buildup were the three water rings at the Magenta, the Culebra, and the key, and along upper portions of the shaft generally associated with power cables, support brackets, instrument cables, and the air lines and water-lines.

Geotechnical Analysis Report for July 2012 – June 2013
DOE/WIPP-14-3516, Vol. 1

Though the Magenta and Culebra water rings are encrusted with salt buildup, no water appears to originate from the liner or water rings. Most of the seepage was observed along the east face of the shaft wall near the instrumentation cables and the air lines and water-lines in the upper section of the shaft. Though the presence of water is an inconvenience requiring periodic disposal, at this time it does not appear to have created any hazard or affected the structural integrity of the shaft. However, brine increases the probability of corrosion and deterioration of utility hangers and brackets. There are no visible signs of dissolution of the salt below the key.

The video inspections also focused on the installed utilities and support brackets. These include a 13.8 kVA power cable that is no longer active and the grounding cable on the west wall of the shaft, the instrumentation cables on the northeast wall of the shaft, and the 4 in. air-line and the 2-in. water-line on the east wall of the shaft.

Sporadic salt buildup continues on all cables. The long-term implication of salt buildup is increased loading on cables and cable hangers, accompanied by intermittent falls of debris. The 4-in. compressed air-line and the 2-in. water-line extend from the surface to the bottom of the shaft. At present, neither line is being used. The integrity of the brackets holding the air-line and water-line was difficult to assess because of salt buildup; however, there was no indication that the brackets were broken. Instrumentation cable breaks were observed in the shaft; however, most of these breaks affected abandoned cables, with negligible impact on shaft monitoring and operations.

3.3.1.3 Instrumentation

The Exhaust Shaft was equipped with geomechanical instrumentation in two stages. Earth pressure cells were installed behind the liner key in November 1984. Piezometers and nine multi-position extensometers were installed during November and December 1985. Figure 3-12 and Figure 3-13 show the instrument locations. None of these instruments continues to provide data.

3.4 Air Intake Shaft

The Air Intake Shaft was drilled from December 4, 1987, to August 31, 1988, to establish a primary route for surface air to enter the repository (see Figure 1-2). The stratigraphy was mapped from September 14, 1988, to November 14, 1989 (Holt and Powers, 1990). Figure 3-14 summarizes the shaft stratigraphy.

The Air Intake Shaft is lined with non-reinforced concrete from the surface to the bottom of the shaft key at 903 ft (275 m). The key is 81 ft (25 m) long with an inside diameter of 16 ft (5 m). The shaft diameter below the key is 20 ft (6 m), and the shaft below the key is unlined to the facility horizon at 2,150 ft (655 m). The shaft walls are bolted and meshed from just below the key all the way down to the shaft station. This shaft has no sump.

3.4.1 Shaft Performance

Weekly visual inspections were performed on the Air Intake Shaft during this reporting period, and the shaft was found to be in satisfactory condition. No ground control activities other than routine maintenance were required during this reporting period.

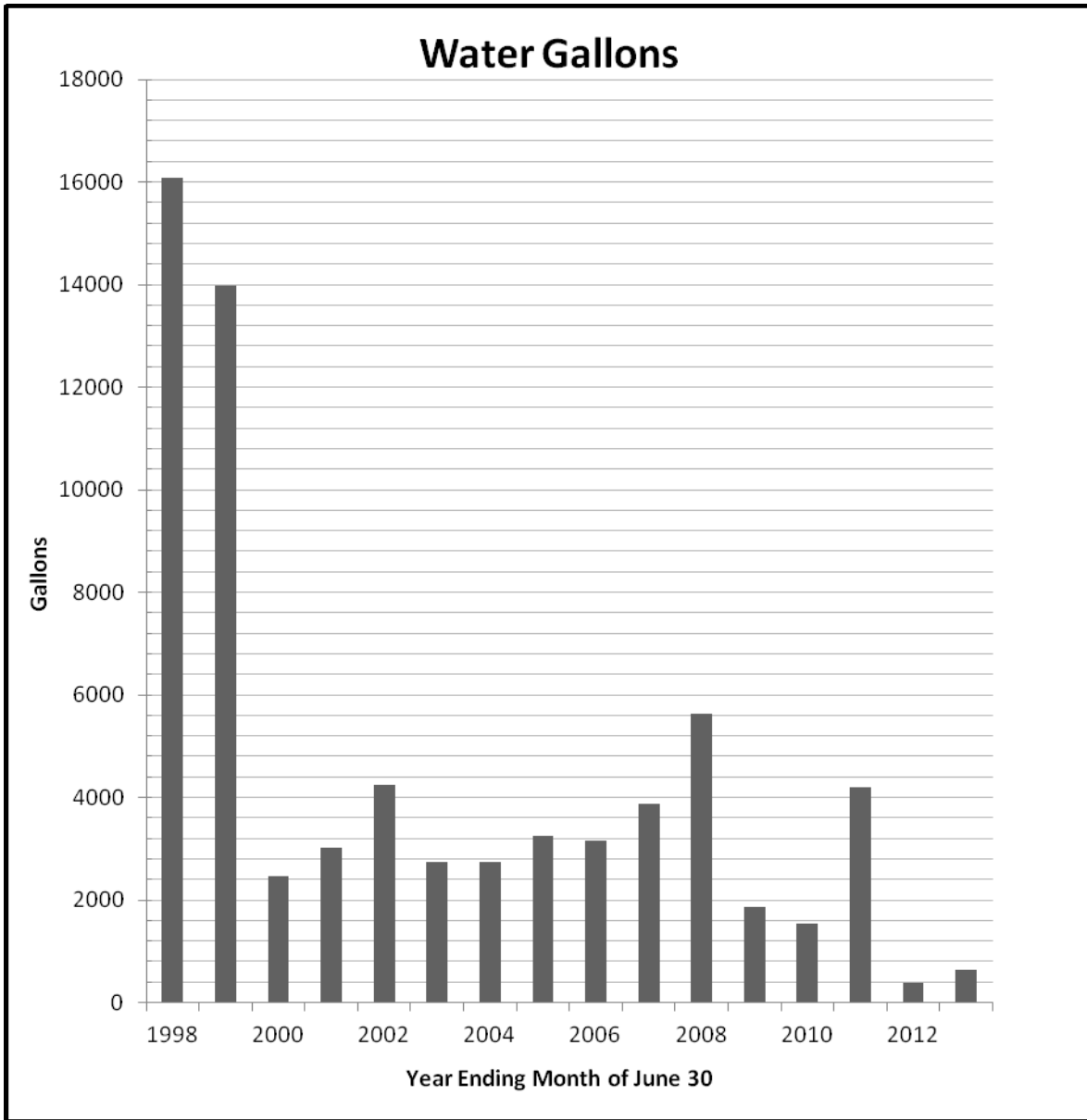

Figure 3 - 11 Water Removed from the Exhaust Shaft Catch Basin and the Interception Well System

**Geotechnical Analysis Report for July 2012 – June 2013
DOE/WIPP-14-3516, Vol. 1**

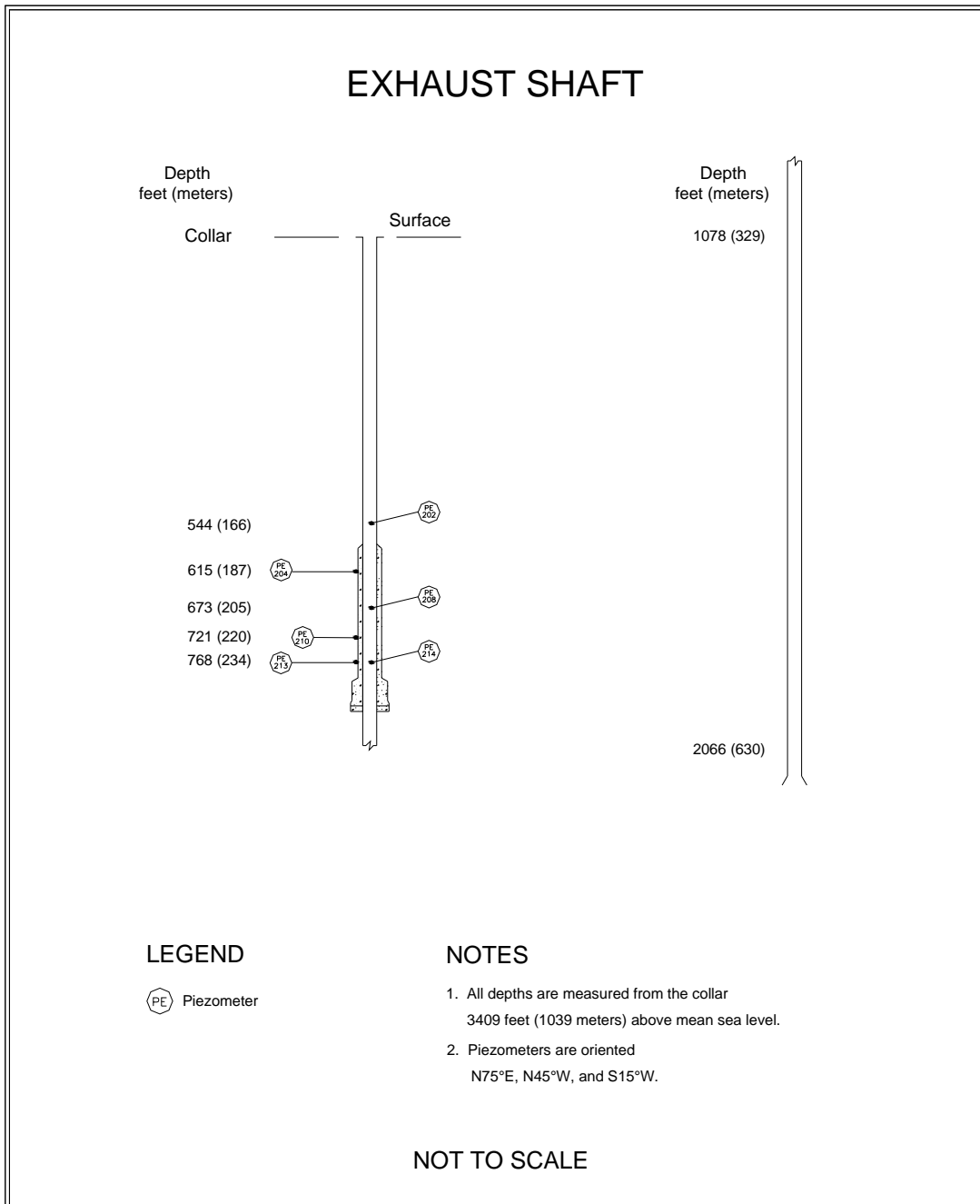

Figure 3 - 12 Exhaust Shaft Instrumentation (Without Shaft Key)

**Geotechnical Analysis Report for July 2012 – June 2013
DOE/WIPP-14-3516, Vol. 1**

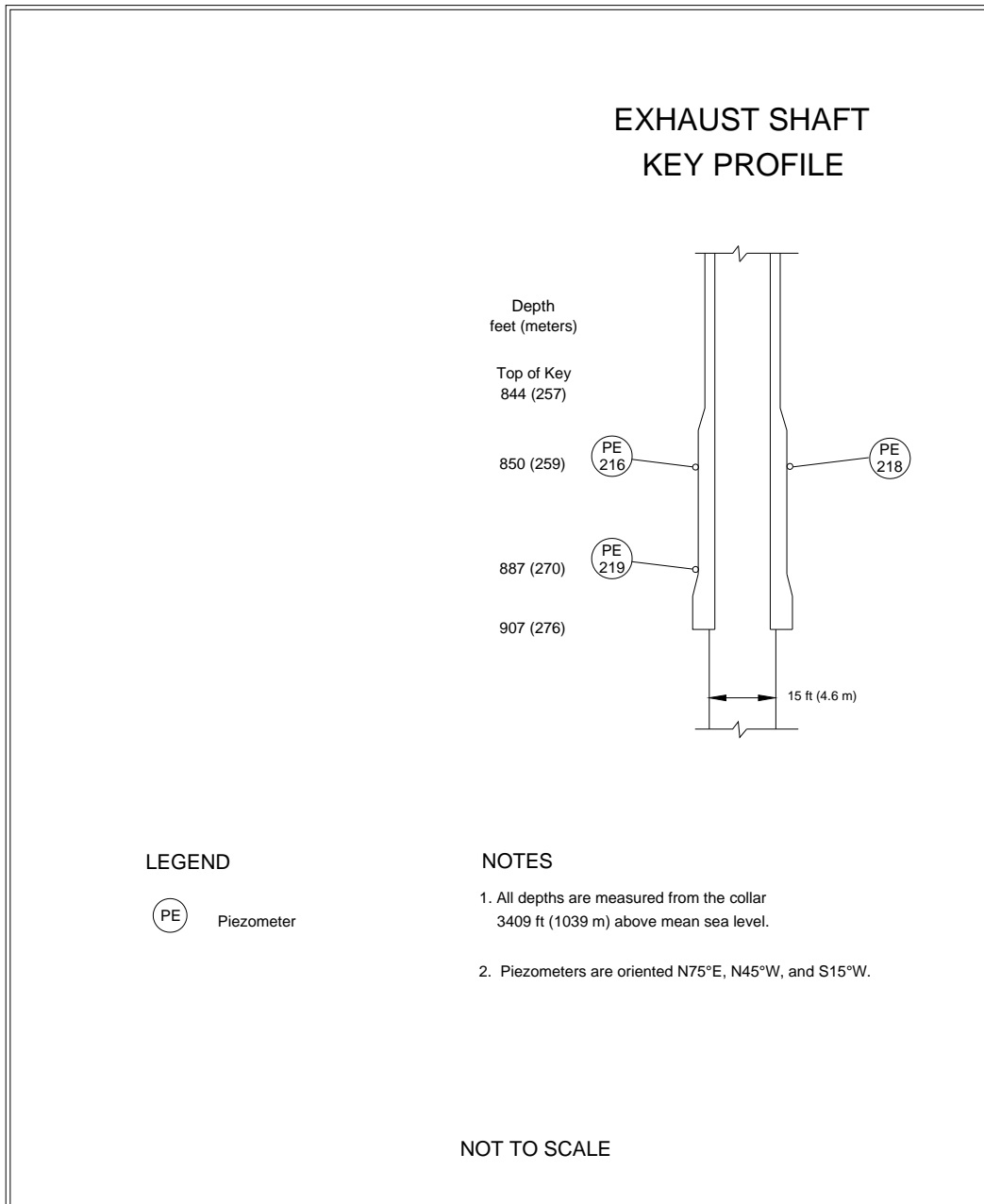

Figure 3 - 13 Exhaust Shaft Key Instrumentation

**Geotechnical Analysis Report for July 2012 – June 2013
DOE/WIPP-14-3516, Vol. 1**

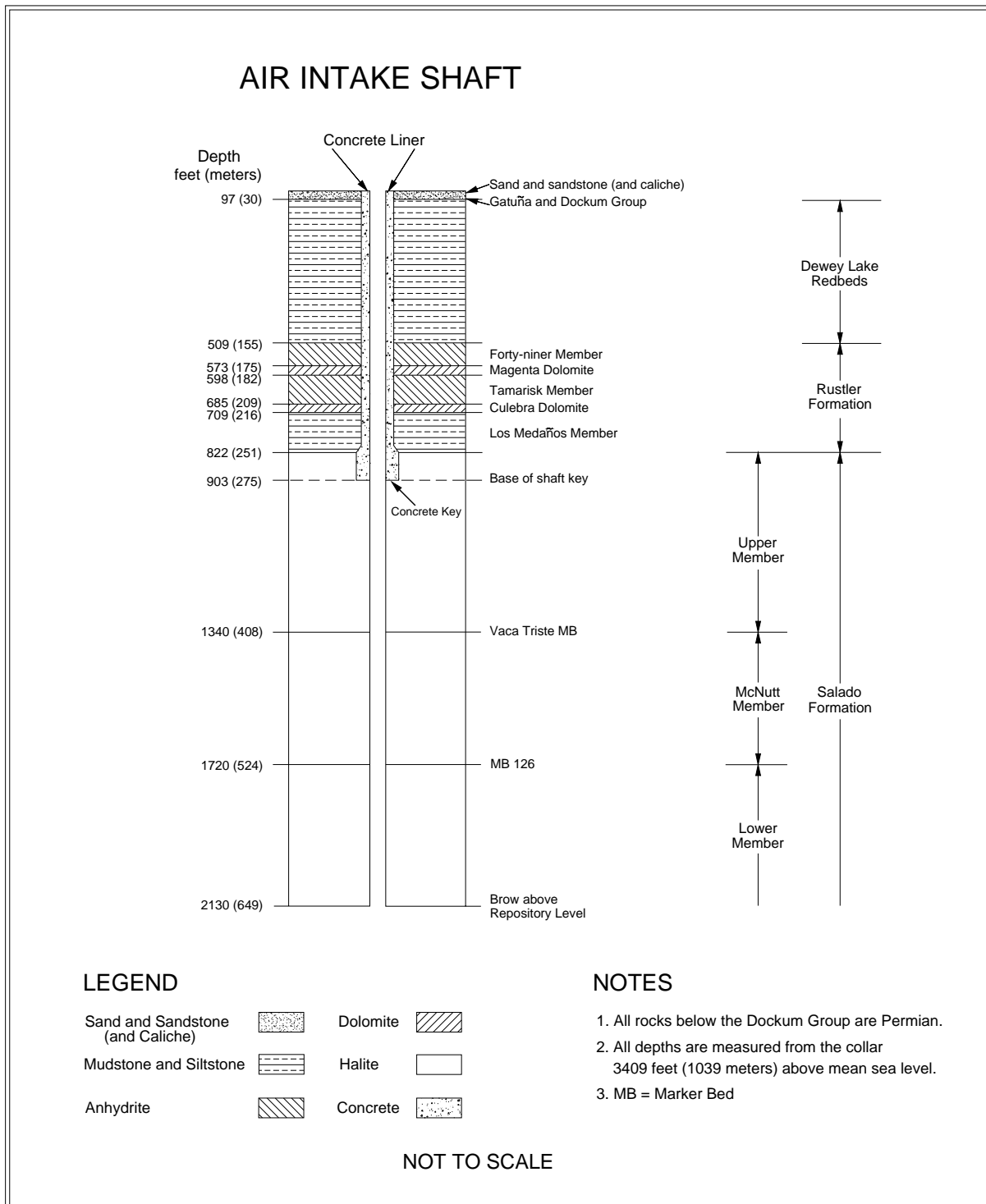

Figure 3 - 14 Air Intake Shaft Stratigraphy

4.0 PERFORMANCE OF SHAFT STATIONS

This chapter describes the instrumentation and geomechanical performance of the shaft stations at the base of the Salt Shaft, the Waste Shaft, and the Air Intake Shaft. The Exhaust Shaft does not have an enlarged shaft station; therefore, it is not included in this chapter.

4.1 Salt Shaft Station

The Salt Shaft Station was excavated by drilling and blasting between May 2 and June 3, 1982. In 1987 the station was enlarged by removing the roof beam up to Anhydrite "b" between S-90 and N-20 using a mechanical scaler. In 1995, the remaining roof beam at the north end of the station was also removed up to Anhydrite "b." The station area south of the shaft is 90 ft (27.5 m) long and 32 to 38 ft (10 to 12 m) wide. The height of the station south of the shaft is 18 ft (5.5 m). The station dimensions north of the shaft are approximately 30 ft (9 m) long, 32 to 35 ft (10 to 11 m) wide, and 18 ft (5.5 m) high. The shaft extends approximately 140 ft (43 m) below the facility horizon to accommodate the skip loading equipment and a sump. Figure 4-1 shows a cross section of the station.

4.1.1 Modifications to Excavation and Ground Control Activities

The Salt Shaft Station was not modified during this reporting period. Ground control activities were limited to routine maintenance.

4.1.2 Instrumentation

Geomechanical instrumentation was installed in the Salt Shaft Station between June 1982 and February 1983, with subsequent re-installation of extensometers and convergence points as necessary. Figure 4-2 shows the instrument locations after the roof beam was taken down.

Five vertical convergence points are currently monitored. Table 4-1 summarizes the vertical closure rates in the Salt Shaft Station from July 2012 through June 2013. Salt Shaft Station vertical closure rates indicate that the rates are lower than during the previous reporting period.

Table 4-2 summarizes the recent history of the roof extensometers in the Salt Shaft Station. Extensometers 51X-GE-01026-2 (S-30) and 51X-GE-01027-2 (S60) are located in the roof of the station.

**Geotechnical Analysis Report for July 2012 – June 2013
DOE/WIPP-14-3516, Vol. 1**

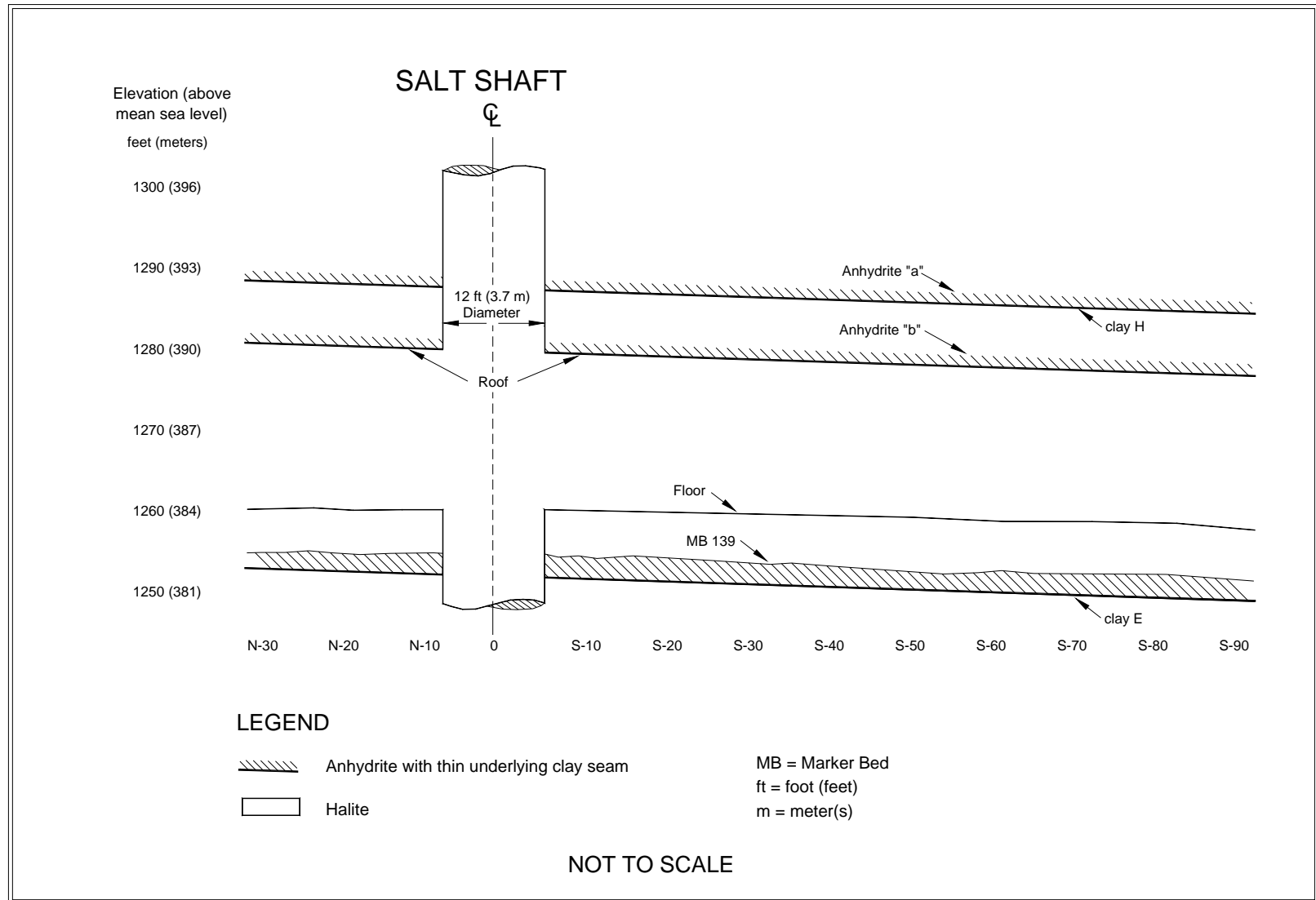

Figure 4 - 1 Salt Shaft Station Stratigraphy

Geotechnical Analysis Report for July 2012 – June 2013
DOE/WIPP-14-3516, Vol. 1

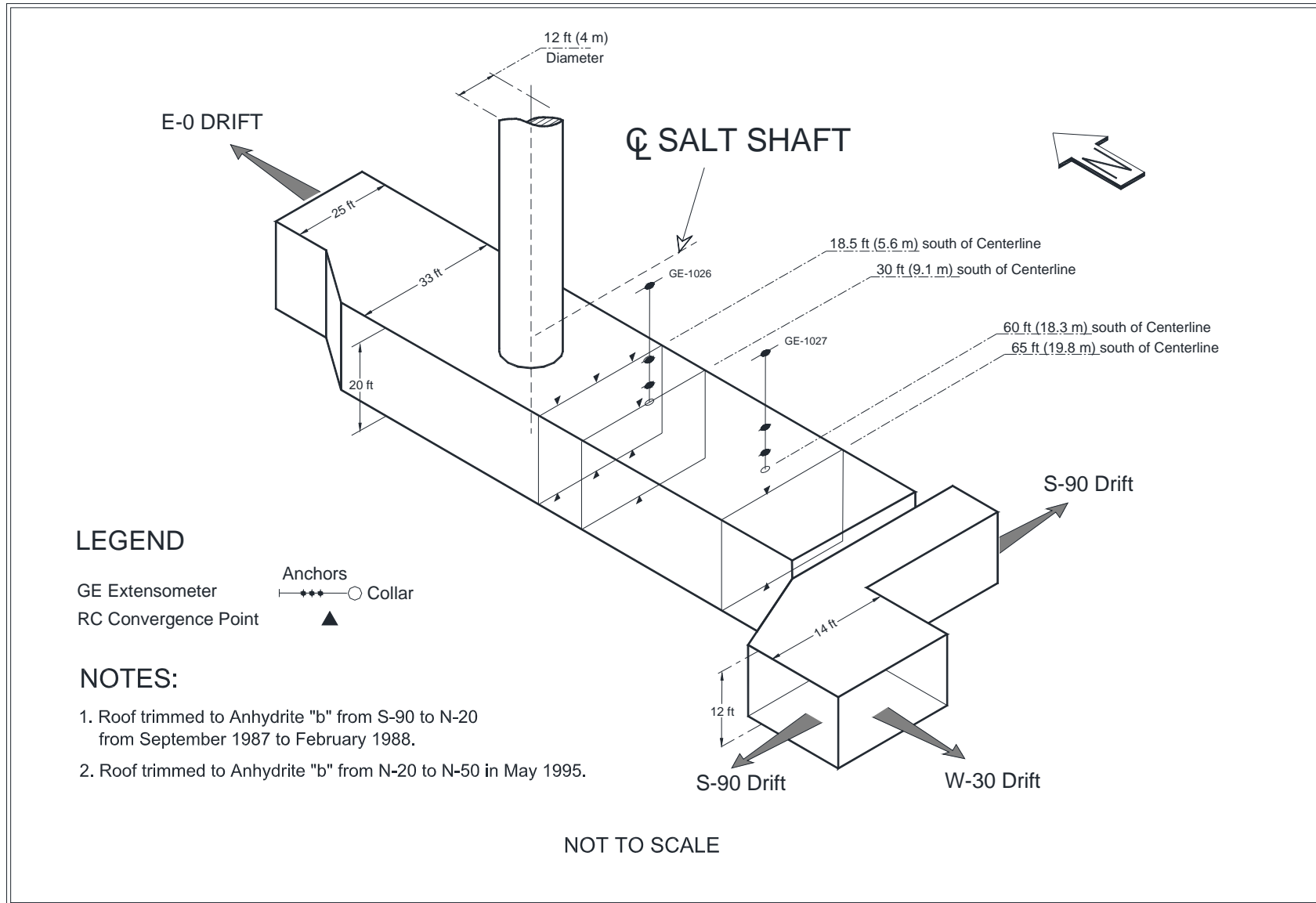

Figure 4 - 2 Salt Shaft Station Instrumentation after Roof Beam Excavation

Geotechnical Analysis Report for July 2012 – June 2013
DOE/WIPP-14-3516, Vol. 1

Table 4 - 1 Closure Rates in the Salt Shaft Station

Location	Chord ¹	Last Reading	Total Cumulative Displacement in (cm)	Closure Rate 2012-2013 in/yr (cm/yr)	Closure Rate 2011-2012 in/yr (cm/yr)	Rate Percent Change
E0-S18	A-E	06/05/13	23.658 (60.091)	1.7 (4.3)	2.5 (6.4)	-32%
E0-S18	B-D	06/05/13	25.866 (65.700)	1.9 (4.8)	2.6 (6.6)	-27%
E0-S18	H-F	06/05/13	16.037 (40.734)	1.1 (2.8)	1.5 (3.8)	-27%
E0-S30	A-C	06/05/13	24.499 (62.227)	1.7 (4.3)	2.3 (5.8)	-26%
E0-S65	A-C	06/05/13	17.068 (43.353)	1.2 (3.0)	1.5 (3.8)	-20%

¹ Chord is defined in Section 5.3

Table 4 - 2 Roof Beam Displacement in the Salt Shaft Station

Instrument	Location	Last Reading	Displacement Relative to Deepest Anchor in (cm)	Displacement Rate 2012 to 2013 in/yr (cm/yr)	Displacement Rate 2011 to 2012 in/yr (cm/yr)	Rate Percent Change
51X-GE-01026-2	E0-S30	06/05/13	1.213 (3.081)	0.4 (1.0)	0.4 (1.0)	0%
51X-GE-01027-2	E0-S60	06/05/13	0.816 (2.073)	0.3 (0.8)	0.2 (0.5)	50%

4.2 Waste Shaft Station

The Waste Shaft Station was initially excavated with a continuous miner as a ventilation connection to a 6-ft (2-m) diameter exhaust shaft in November 1982. In 1984, the station was enlarged to a height of 15 to 20 ft (4.5 to 6 m) and a width of 20 to 30 ft (6 to 9 m). The station is approximately 150 ft (46 m) long. In 1988, the station walls were trimmed, and concrete was placed on the floor. Since 1988, the Waste Shaft Station has undergone five major floor renovations. A 53-ft (16-m)-long section of the reinforced concrete was removed in February 1991, in 1995 an additional 30-ft (9-m) section was removed, and in 2000 floor maintenance included trimming of the floor and reinstallation of the rails supported by segmented concrete panels on a crushed rock backfill. The roof of the Waste Shaft station was mined up to Clay G in December 2008 to assure adequate operational clearance. 12-ft resin-anchored roof bolts and chain link were installed for ground support. Figure 4-3 shows a cross-section of the Waste Shaft Station.

4.2.1 Modifications to Excavation and Ground Control Activities

No modifications to the Waste Shaft Station were made during this reporting period. Ground control activities were limited to routine maintenance.

**Geotechnical Analysis Report for July 2012 – June 2013
DOE/WIPP-14-3516, Vol. 1**

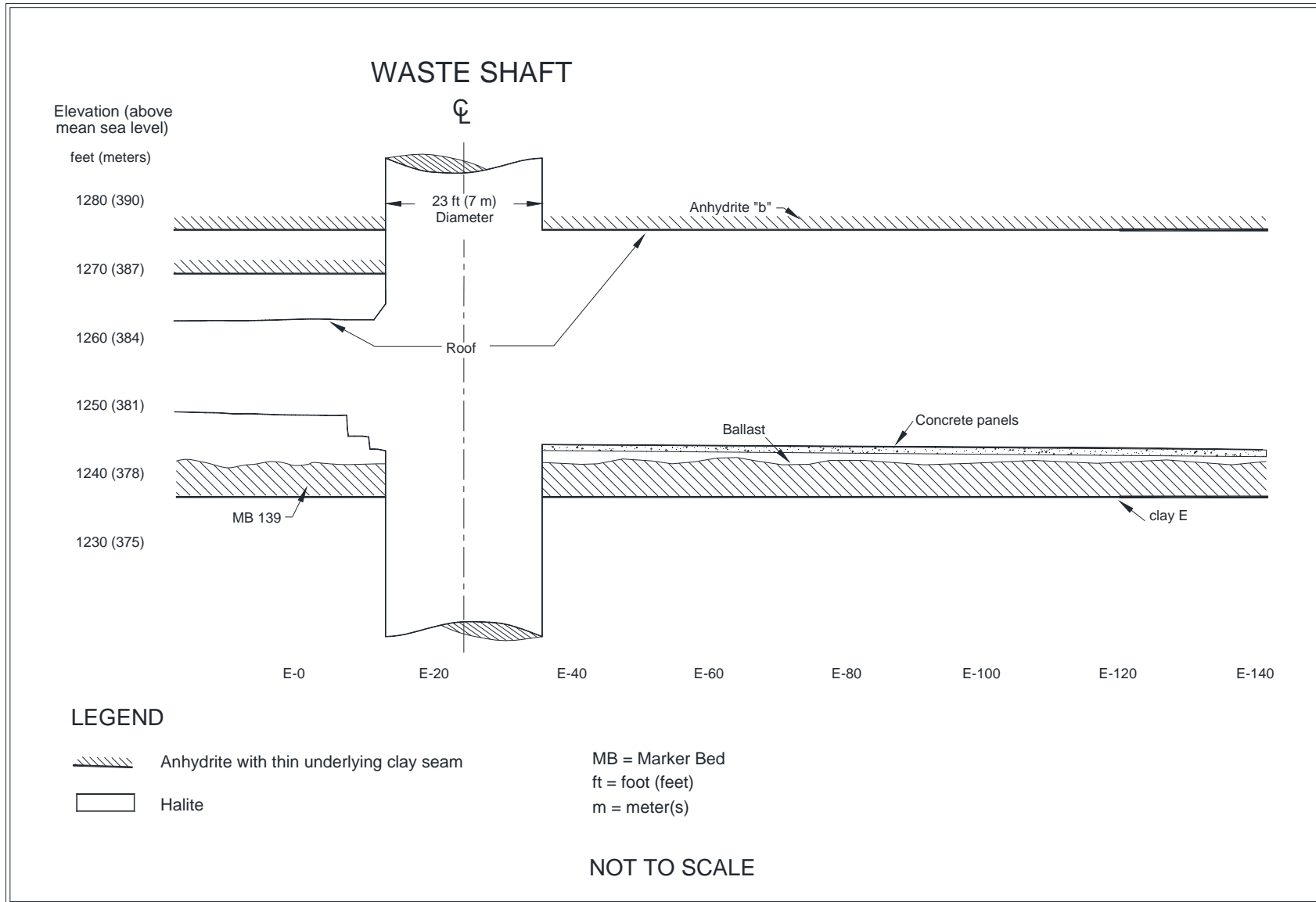

Figure 4 - 3 Waste Shaft Station Stratigraphy

Geotechnical Analysis Report for July 2012 – June 2013
DOE/WIPP-14-3516, Vol. 1

4.2.2 Instrumentation

Instruments were initially installed in the Waste Shaft Station between November 12 and December 2, 1982. Figure 4-4 illustrates the locations after enlargement. Two extensometers in the Waste Shaft Station are currently being monitored. In addition, horizontal convergence is being monitored at E-32 and E-85.

Table 4-3 summarizes the recent history of the roof extensometers in the Waste Shaft Station. Extensometer 51X-GE-00404-2 is located at approximately S400-E35.

Table 4-4 summarizes the annual horizontal closure rates calculated from convergence point data for this reporting period. The data indicate that the horizontal closure rates at both E-32 and E-85 have not changed significantly from the previous reporting period.

Table 4 - 3 Summary of Roof Extensometers in Waste Shaft Station

Instrument	Location	Last Reading	Displacement Relative to Deepest Anchor in (cm)	Displacement Rate 2012 to 2013 in/yr (cm/yr)	Displacement Rate 2011 to 2012 in/yr (cm/yr)	Rate Change Percent
51X-GE-00268	S400-W30	06/05/13	11.079 (28.141)	0.0 (0.0)	0.1 (0.3)	-100%
51X-GE-00404-2	S400-E35	06/28/13	0.934 (2.372)	0.3 (0.8)	0.3 (0.8)	0%

Table 4 - 4 Closure Rates in the Waste Shaft Station

Location	Chord ¹	Last Reading	Cumulative Displacement in (cm)	Closure Rate 2012 to 2013 in/yr (cm/yr)	Closure Rate 2011 to 2012 in/yr (cm/yr)	Rate Change Percent
S400-E32	B-D	06/25/13	5.690 (14.453)	1.4 (3.6)	1.2 (3.0)	17%
S400-E85	B-D	06/25/13	5.780 (14.681)	1.4 (3.6)	1.2 (3.0)	17%

¹ Chord is defined in Section 5.3

**Geotechnical Analysis Report for July 2012 – June 2013
DOE/WIPP-14-3516, Vol. 1**

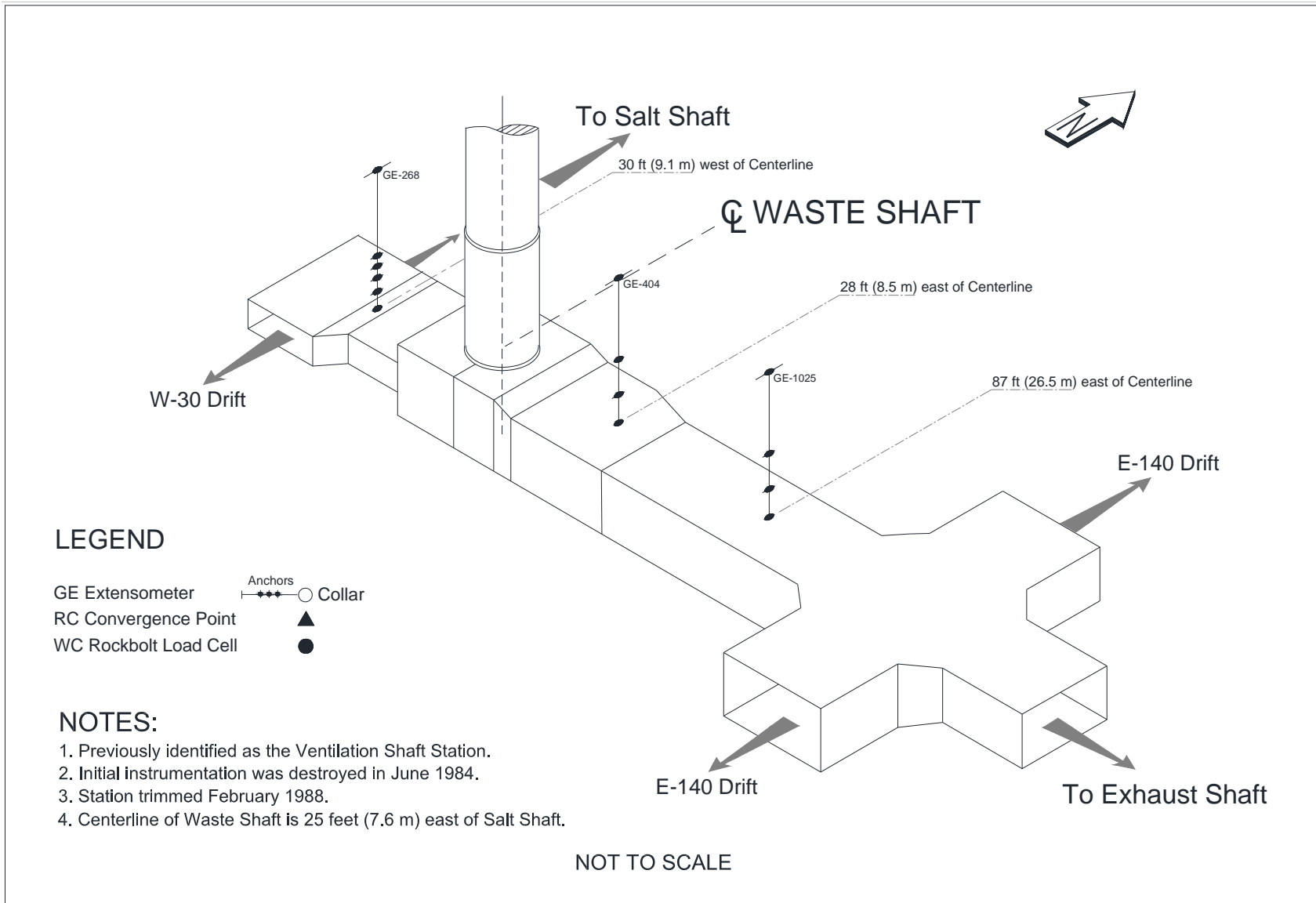

Figure 4 - 4 Waste Shaft Station Instrumentation after Roof Beam Excavation

4.3 Air Intake Shaft Station

The Air Intake Shaft Station was excavated in late 1987 and early 1988, using a continuous miner. The Air Intake Shaft is furnished with a work platform and a small cage that can be raised and lowered to perform routine ground maintenance. The principal purpose of that equipment is to provide emergency access.

4.3.1 Modifications to Excavation and Ground Control Activities

The AIS station was not modified during this reporting period. Ground control activities were limited to routine maintenance.

4.3.2 Instrumentation

Radial convergence point and extensometer instrumentation data near the Air Intake Shaft Station are presented in Chapter 5.0 as part of the discussion on the performance of the access drifts. Twenty rock bolt load cells are installed in the Air Intake Shaft Station area and are monitored regularly.

5.0 PERFORMANCE OF ACCESS DRIFTS

This chapter describes the geomechanical performance of the underground access drifts. The Waste Disposal Area is discussed in Chapter 6.0 and the Salt Disposal Investigation areas are discussed in Chapter 7.0. Four major north-south drifts in the WIPP underground are intersected by shorter east-west cross-drifts. Drift dimensions range from 13 ft (4 m) to 21 ft (6.4 m) high and from 14 ft (4.3 m) to 33 ft (9.2 m) wide.

5.1 Modifications to Excavation and Ground Control Activities

Trimming, scaling, and floor milling activities were performed as necessary in many areas. Table 5-1 summarizes these activities. It also summarizes ground control activities (e.g., rock bolting and installing wire mesh) in various locations in the access drifts.

5.2 Instrumentation

This section discusses instrumentation details and locations for each instrumentation type.

5.2.1 Extensometers

Thirty-five extensometers continue to be monitored at various locations in the access drifts. Where displacement data were available, annual displacement rates were calculated (see Section 1.4.3) for each active installation and compared to the annual displacement rates from the previous reporting period.

**Geotechnical Analysis Report for July 2012 – June 2013
DOE/WIPP-14-3516, Vol. 1**

Table 5 - 1 Summary of Modifications and Ground Control Activities in the Access Drifts July 1, 2012 to June 30, 2013	
Location	Work Activity
Panel 6 Rooms 2 and 3	Installed 4ft mechanical rockbolts and chainlink mesh on ribs and/or back
W170 from S90 to S2180	Installed 4ft mechanical rockbolts and chainlink mesh on ribs and/or back
E300 from S2520 to S3080	Installed 4ft mechanical rockbolts and chainlink mesh on ribs and/or back
E300 from S1600 to S2180	Installed 4ft mechanical rockbolts and chainlink mesh on ribs and/or back
S3650 from E140 to W170	Installed 4ft mechanical rockbolts and chainlink mesh on ribs and/or back
E140 from S2520 to S2750	Installed 4ft mechanical rockbolts and chainlink mesh on ribs and/or back
E140 from S700 to S2180	Installed 4ft mechanical rockbolts and chainlink mesh on ribs and/or back
S2750 from E140 to W170	Replaced broken resin anchored rockbolts
S700 from E200 to W170	Replaced broken resin anchored rockbolts
AIS access drifts N215 and N300	Replaced broken resin anchored rockbolts
W30 from S2750 to S3310	Replaced broken resin anchored rockbolts
S1950 from W30 to W170	Replaced broken resin anchored rockbolts
W170 from S2750 to S3080	Replaced broken resin anchored rockbolts
S1600 from W30 to E140	Replaced broken resin anchored rockbolts
S3080 from W30 to W170	Replaced broken resin anchored rockbolts
N620 alcove	Replaced broken resin anchored rockbolts
Panel 6 Rooms 2 and 3	Installed 14ft resin anchored rockbolt pattern
S3650 from E140 to Panel 5 closure	Installed 14ft resin anchored rockbolt pattern
S2520 from E140 to Panel 6 Room 1	Installed 14ft resin anchored rockbolt pattern
S3310 from W170 to Panel 5 closure	Installed 14ft resin anchored rockbolt pattern
S1950 from E300 to Panel 1 closure	Installed 14ft resin anchored rockbolt pattern
E300 maintenance shop	Installed 14ft resin anchored rockbolt pattern
E140 from N780 to N940	Installed 14ft resin anchored rockbolt pattern
E0 from N1254 to N1304	Installed 14ft resin anchored rockbolt pattern
E0 from N150 to N460	Installed 14ft resin anchored rockbolt pattern
W30 S2520	Trim floor
E140 S3080	Trim floor
E140 from S300 to S350	Trim floor
S2750 from W30 to Panel 6, Room 1	Trim floor
W30 from S2750 to S3080	Trim floor
E140 from S700 to S2520	Trim floor
E140 from S700 to S2520	Trim floor
W30 S90	Trim floor
E140 S2520	Trim floor and miters

Geotechnical Analysis Report for July 2012 – June 2013
DOE/WIPP-14-3516, Vol. 1

Table 5 - 1 Summary of Modifications and Ground Control Activities in the Access Drifts July 1, 2012 to June 30, 2013	
E300 Maintenance Shop alcoves and main area (N250 to S90)	Trim floor
W170 S2000	Trim rib
E140 S200	Trim floor
E140 S2180	Trim floor
E140 S600	Trim floor
W30 S800	Trim floor
S700 W30-E140	Trim floor
W170 from S2750 to S3080	Trim floor
E140 S2520	Trim floor
S90 E300	Trim floor
E140 S2520	Trim floor
W170 S2750 to S3080	Trim floor
S2750 from W30 to E140	Trim floor
S1600 from W30 to W170	Trim floor
W30 from S1600 to S1950	Trim floor

Extensometer data are obtained by measuring the displacement from the reference head anchor (collar) to each fixed anchor of the extensometer. These measurements are scheduled to be made at least monthly throughout the WIPP underground.

Many of the E-140 extensometers indicate movement in the roof beam that may be attributed to shallow fracturing and the effects of anhydrite stringer separations in the roof. Lateral deformation in the roof beam may influence the extensometer readings, causing an increase in the measured displacement. Although the extensometer data indicate continued deformation and breakup of the lower beam, the roof bolt anchorage zone remains competent.

5.2.2 Convergence Points

Convergence point data are obtained by measuring the change in distance between fixed points anchored into the rock across an opening, either from rib to rib or from roof to floor. The measurement end-points constitute a "chord." Figure 5-1 shows typical convergence point array configurations along with typical chord designations.

Convergence points installed during this reporting period involved the replacement of arrays in previously mined areas and the installation of new monitoring arrays in newly mined areas. Replacement convergence points were installed in twenty-three locations throughout the WIPP underground access drifts. Most of these installations were located in E-140 and W-30, where floor trimming activities removed the existing points.

Geotechnical Analysis Report for July 2012 – June 2013
DOE/WIPP-14-3516, Vol. 1

Table 5-2 lists the replacement convergence points that were installed during this reporting period.

Where possible, annual closure rates were calculated from convergence point array data gathered in the access drifts. Approximately 360 convergence points are located in the access drifts. A complete tabulation of these convergence point data and calculated closure rates is presented in the supporting data document for this report.

Locations with increases in annual vertical closure rates of greater than twenty percent are shown in Table 5-3.

Table 5 - 2 New and Replacement Convergence Points Installed In the Access Drifts July 1, 2012 through June 30, 2013				
LOCATION	New/Replaced	Fieldtag ¹	CHORD ²	Date Installed
E300-N1262	R	E300-N1262-4	A-C	9/26/2012
E300-N1341	R	E300-N1341-3	A-C	9/26/2012
E140-S262	R	E140-S262-5	A-C	11/19/2012
E140-N150	R	E140-N150-5	A-C	11/19/2012
S2750-W93	R	S2750-W93-3	A-C	1/22/2013
W30-S2833	R	W30-S2833-4	A-C	1/22/2013
W30-S2916	R	W30-S2916-2	A-C	1/22/2013
W30-S2998	R	W30-S2998-2	A-C	1/22/2013
W30-S2750	R	W30-S2750-3	A-C	1/25/2013
E140-S2750	R	E140-S2750-4	A-C	3/7/2013
E140-S2634	R	E140-S2634-2	A-C	3/7/2013
E140-S2520	R	E140-S2520-4	A-C	3/7/2013
E140-S2425	R	E140-S2425-6	A-C	3/7/2013
E140-S2350	R	E140-S2350-7	A-C	3/7/2013
E140-S2122	R	E140-S2122-6	A-C	3/7/2013
E140-S2065	R	E140-S2065-7	A-C	3/8/2013
E140-S2007	R	E140-S2007-8	A-C	3/8/2013
E140-S1950	R	E140-S1950-7	A-C	3/8/2013
E140-S1862	R	E140-S1862-4	A-E	3/8/2013
E140-S1862	R	E140-S1862-4	B-D	3/8/2013
E140-S1862	R	E140-S1862-4	H-F	3/8/2013
E140-S1775	R	E140-S1775-4	A-G	3/8/2013
E140-S1775	R	E140-S1775-5	B-F	3/8/2013
E140-S1775	R	E140-S1775-4	L-H	3/8/2013
E140-S1687	R	E140-S1687-4	A-E	3/8/2013
E140-S1687	R	E140-S1687-4	H-F	3/8/2013
E140-S2275	R	E140-S2275-7	A-C	3/8/2013

Geotechnical Analysis Report for July 2012 – June 2013
DOE/WIPP-14-3516, Vol. 1

Table 5 - 2 New and Replacement Convergence Points Installed In the Access Drifts July 1, 2012 through June 30, 2013				
LOCATION	New/Replaced	Fieldtag¹	CHORD²	Date Installed
E140-S1687	R	E140-S1687-4	B-D	3/13/2013
E140-S1600	R	E140-S1600-7	A-C	3/13/2013
E140-S1534	R	E140-S1534-5	B-D	3/13/2013
E140-S1534	R	E140-S1534-4	A-E	3/13/2013
E140-S1534	R	E140-S1534-4	H-F	3/13/2013
E140-S1450/1456	R	E140-S1450-4	B-F	3/13/2013
E140-S1450/1456	R	E140-S1450-6	A-G	3/13/2013
E140-S1450/1456	R	E140-S1450-4	L-H	3/13/2013
E140-S1378	R	E140-S1378-4	H-F	3/13/2013
E140-S1378	R	E140-S1378-4	A-E	3/13/2013
E140-S1378	R	E140-S1378-4	B-D	3/13/2013
E140-S1300	R	E140-S1300-5	A-C	3/19/2013
E140-S1225	R	E140-S1225-4	H-F	3/20/2013
E140-S1225	R	E140-S1225-5	A-E	3/20/2013
E140-S1225	R	E140-S1225-5	B-D	3/20/2013
E140-S1150	R	E140-S1150-6	L-H	3/20/2013
E140-S1150	R	E140-S1150-5	A-G	3/20/2013
E140-S1075	R	E140-S1075-5	B-D	3/20/2013
E140-S1075	R	E140-S1075-5	A-E	3/20/2013
E140-S1075	R	E140-S1075-5	H-F	3/20/2013
E140-S1150	R	E140-S1150-7	B-F	3/22/2013
E140-S1025	R	E140-S1025-5	A-C	3/22/2013
E140-S1000	R	E140-S1000-4	A-C	3/22/2013
E140-S850	R	E140-S850-10	A-C	3/22/2013
E140-N150	R	E140-N150-6	A-C	4/3/2013
E140-N5	R	E140-N5-7	A-C	4/3/2013
E300-S90	R	E300-S90-2	A-C	4/3/2013
E140-N220	R	E140-N220-4	A-C	4/3/2013
E140-S2122	R	E140-S2122-7	A-C	4/24/2013
S1600-E170	R	S1600-E170-2	A-C	5/8/2013
S1600-E110	R	S1600-E110-2	A-C	5/8/2013

N = New installation.

R = Replacement installation (i.e., instrument replaces older instrument that has failed or has been mined out).

¹ This column is a combination of the convergence point location followed by a "-X," where X represents the reinstatement number, when applicable.

² A unique letter is assigned to each convergence array element around a particular opening. Chord refers to a particular array pair. The various array lettering schemes are shown in Figure 5-1.

5.3 Analysis of Convergence Point and Extensometer Data

Vertical loading on mine pillars results in lateral stresses on the roof and floor beams. The composition of those beams, in part, determines how these structures will react to the horizontal stresses. In particular, horizontally continuous anhydrite stringers (see Section 2.2.2) divide the beam itself into a series of smaller independent beams.

Lateral strain on the beam imposed by vertical loading on the pillars is accommodated by vertical displacement over the mined opening. This requires that the horizontally oriented beam separate along the most favorable, or weakest, planes.

Where anhydrite stringers interpose the beam, they constitute a plane of weakness, and delamination occurs. The material is confined in the plane above, so that the roof accommodates the lateral strain by bending convex into the mined opening.

Two distinct results come of this action. First, voids form within the beam as the portions closer to the opening move away from those deeper within the beam. Second, the convex portion of the bended plane is subjected to tensile loading perpendicular to the axis of the drift and superficial tears known as "tensile fractures" develop generally parallel to the axis of the drift.

Where anhydrite stringers are small and discontinuous or not present at all within the beam, horizontal loading is accommodated along shear planes. These develop at angles of approximately 35 degrees with respect to the horizontal. In some cases, a plane develops preferentially on one side of the drift, and the bulk of material is pushed into the mined opening on that side. This may be thought of as a cantilevered beam.

Whatever the mechanism, vertical displacement into the mined opening is measured by convergence monitoring. Convergence points consider the displacement between two opposing surfaces: either the roof and floor or the two ribs. Extensometers consider the displacement between one surface (usually the back) and one or more points within the beam. Where a convergence point and an extensometer are adjacent to one another, it is possible to determine the individual displacements of both floor and roof beams.

This data is used to analyze the stability and mechanics of the beam, and in determining what actions may be taken to ensure the safety of personnel and equipment consistent with the safe operation of the facility.

TYPICAL CONVERGENCE POINT ARRAY CONFIGURATIONS

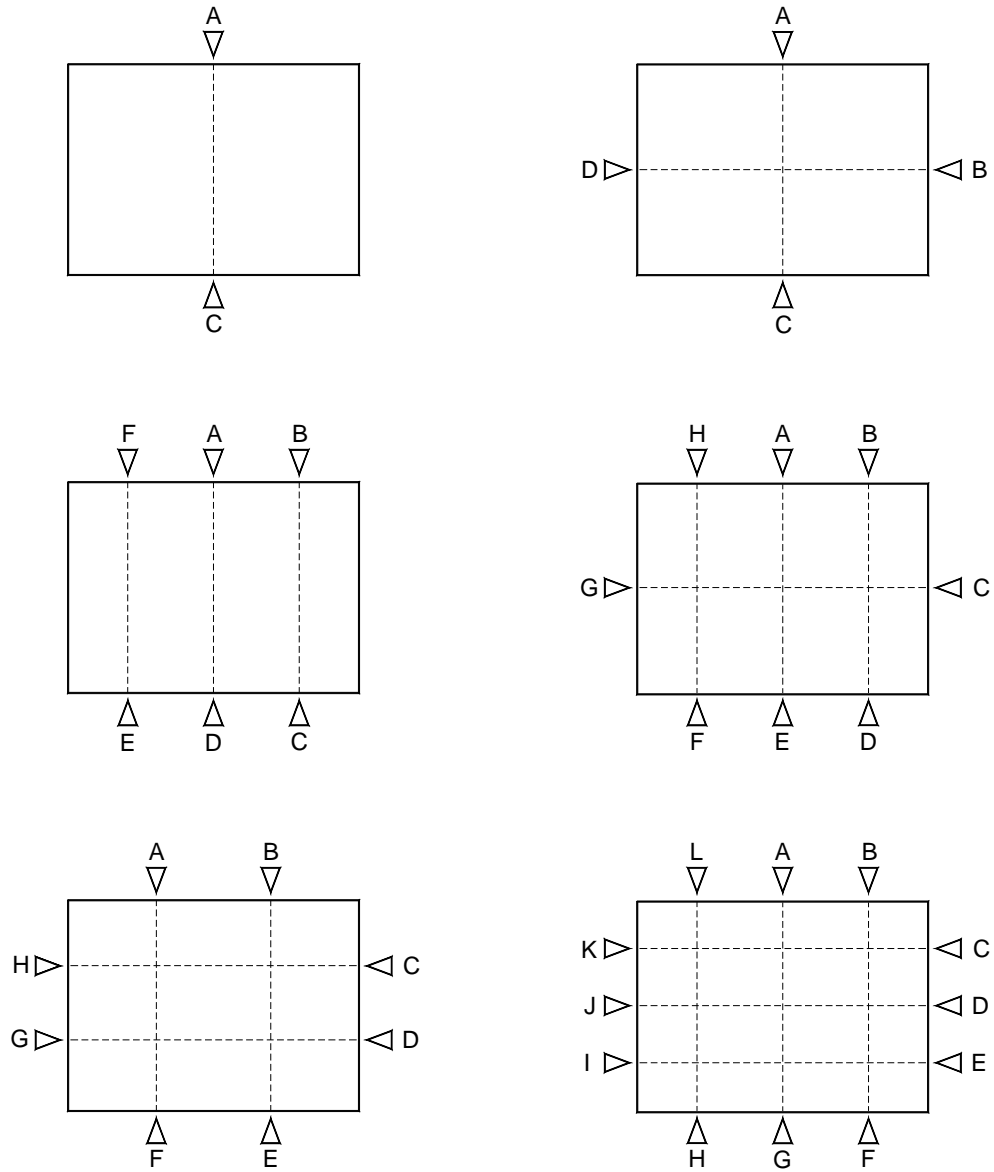

Figure 5 - 1 Typical Convergence Point Array Configurations Showing Anchor Designations

**Geotechnical Analysis Report for July 2012 – June 2013
DOE/WIPP-14-3516, Vol. 1**

Table 5 - 3 Vertical Closure Rate Changes in Excess of Twenty Percent in the Access Drifts

Location	Chord	Last Reading Date	Closure Rate 2012 to 2013 in/yr (cm/yr)	Closure Rate 2011 to 2012 in/yr (cm/yr)	Rate Percent Change
E140-N220	A-C	06/11/13	3.6 (9.1)	2.5 (6.4)	44%
E140-N150	A-C	06/11/13	2.2 (5.6)	1.8 (4.6)	22%
E140-N5	A-C	06/11/13	3.0 (7.6)	2.4 (6.1)	25%
E140-S90	A-C	06/25/13	2.1 (5.3)	1.5 (3.8)	40%
E140-S1000	A-C	06/25/13	2.3 (5.8)	1.4 (3.6)	64%
E140-S1075	A-E	06/25/13	3.2 (8.1)	2.5 (6.4)	28%
E140-S1075	H-F	06/25/13	2.1 (5.3)	1.7 (4.3)	24%
E140-S1150	A-G	06/25/13	5.1 (13.0)	4.2 (10.7)	21%
E140-S1150	B-F	05/22/13	3.2 (8.1)	2.1 (5.3)	52%
E140-S1375/1378	A-E	06/25/13	4.5 (11.4)	3.5 (8.9)	29%
E140-S1375/1378	B-D	06/25/13	2.3 (5.8)	1.9 (4.8)	21%
E140-S1375/1378	H-F	06/25/13	5.0 (12.7)	3.8 (9.7)	32%
E140-S1600	A-C	06/25/13	2.7 (6.9)	2.1 (5.3)	29%
E140-S1950	A-C	06/25/13	4.4 (11.2)	3.3 (8.4)	33%
E300-N45	A-E	01/28/13	1.9 (4.8)	1.3 (3.3)	46%
E300-N45	H-F	01/28/13	1.8 (4.6)	1.2 (3.0)	50%
E300-N45	C-G	11/27/12	1.7 (4.3)	1.2 (3.0)	42%
E300-N170	A-E	01/28/13	2.3 (5.8)	1.7 (4.3)	35%
E300-N170	C-G	01/28/13	1.8 (4.6)	1.3 (3.3)	38%
E300-N170	H-F	01/28/13	2.3 (5.8)	1.6 (4.1)	44%
E300-S45	A-E	01/28/13	2.3 (5.8)	1.2 (3.0)	92%
E300-S45	B-D	01/28/13	2.8 (7.1)	1.5 (3.8)	87%
E300-S45	C-G	01/28/13	1.7 (4.3)	0.8 (2.0)	113%
E300-S45	H-F	01/28/13	1.7 (4.3)	1.0 (2.5)	70%
E300-S90	A-C	05/28/13	1.4 (3.6)	0.7 (1.8)	100%
E300-S2916	A-C	05/28/13	3.0 (7.6)	2.4 (6.1)	25%
S1600-E110	A-C	06/26/13	1.5 (3.8)	1.1 (2.8)	36%
S1600-E170	A-C	06/26/13	1.7 (4.3)	1.2 (3.0)	42%
S2750-E220	A-C	06/10/13	3.6 (9.1)	2.6 (6.6)	38%
S3080-W100	A-C	06/10/13	5.4 (13.7)	4.4 (11.2)	23%
S3310-E55	A-C	06/10/13	3.2 (8.1)	2.6 (6.6)	23%
S3650-E220	A-C	06/10/13	3.1 (7.9)	2.4 (6.1)	29%
W170-S1150	B-D	05/07/13	0.9 (2.3)	0.7 (1.8)	29%
W170-S3395	A-C	06/03/13	4.8 (12.2)	3.6 (9.1)	33%
W170-S3480	A-C	06/03/13	5.6 (14.2)	4.0 (10.2)	40%
W30-S400	A-C	06/04/13	0.8 (2.0)	0.5 (1.3)	60%

5.4 Excavation Performance

Approximately 500 readings are collected and assessed regularly from convergence point arrays throughout the WIPP underground. Convergence rates continue to vary seasonally, typically increasing during the warmer summer months and decreasing during the cooler and drier winter months.

The performance of the access drift excavations during this reporting period was within acceptable criteria. "Acceptable criteria" means that a drift remains accessible, and the ground can be controlled by routine maintenance. Standard remedial ground control in some areas was required to maintain the performance of the excavations. The drifts remain stable and controlled. Most of the annualized rates remain steady, indicating stability. In some locations, where the rates are high, nearby mining activity or gradual deterioration of the roof beam along anhydrite stringers is most likely the cause. Where necessary, additional ground control measures have been or will be installed.

6.0 PERFORMANCE OF WASTE DISPOSAL AREA

The Waste Disposal Area as of June 30, 2013, consisted of Panels 1, 2, 3, 4, 5, 6, and 7. Panels 1, 2, 3, 4, and 5 were closed during previous reporting periods. Waste disposal in Panel 6 was ongoing at the end of this reporting period. Panel 7 mining was under way during this reporting period.

6.1 History

Excavation of Panel 1 began in May 1986 with the mining of the access entries. Initially, the disposal rooms and drifts were developed as pilot drifts that were later excavated to nominal operational dimensions of 13 ft (4 m) high, 33 ft (10 m) wide, and 300 ft (91 m) long. Room 1 was completed to these dimensions in August 1986, and pilot drifts for Rooms 2 and 3 were excavated in January and February 1987. Rooms 2 and 3 were completed in February and March 1988, and Rooms 4 through 7 were completed in May 1988. Four short access drifts designed to lead to smaller test alcoves were excavated north off the S-1600 drift and Rooms 4-7 in June 1989. Only the access drifts to the alcoves were completed; the alcoves themselves were not excavated. Panel 1 waste emplacement (in Rooms 1, 2, 3, 7, adjacent areas of S 1600, and all of S-1950) was completed during a prior reporting period, and the panel is closed to all access. The Panel 1 access entries, S-1600 and S-1950, which extend from the E-300 drift to the isolation walls, remain open, and the instrumentation in this area continues to be maintained and monitored.

Excavation of the Panel 2 waste disposal area began in September 1999 with the mining of access entries. Initially, the disposal rooms and drifts were developed as pilot drifts that were trimmed to finished dimensions. Room 1 was completed in January 2000, and pilot drifts for Rooms 2 and 3 were excavated in February 2000. Pilot drifts were completed for Rooms 4 through 6 in April 2000. The pilot drift for Room 7 was excavated in May 2000. All the rooms were excavated to final dimensions by August

Geotechnical Analysis Report for July 2012 – June 2013
DOE/WIPP-14-3516, Vol. 1

2000. Waste emplacement in Panel 2 was completed during a prior reporting period, and the panel is closed to all access. The Panel 2 access entries, S-2150 and S-2520, which extend from the E-300 drift to the isolation walls, remain open, and the instrumentation in this area continues to be maintained and monitored.

Excavation of Panel 3 waste disposal rooms began in May 2002 with the mining of access entries to Panel 3. As with Panel 2, initially, the disposal rooms and drifts were developed as pilot drifts that were trimmed to finished dimensions. All the rooms were excavated to final dimensions by the end of March 2004. Waste emplacement in Panel 3 was completed in February 2007. Substantial barriers and bulkheads were installed in the exhaust and intake drifts of Panel 3 to prevent access into the panel and to isolate it from the ventilation circuit.

Panel 4 access drift mining began in January 2005. The disposal rooms were initially developed as pilot drifts and were later trimmed to final dimensions. Mining was completed by June 2006. Waste emplacement in Panel 4 was completed in March 2009. Substantial barriers and bulkheads were installed in the exhaust and intake drifts of Panel 4 to prevent access into the panel and to isolate it from the ventilation circuit.

Panel 5 excavation activities began in June 2006. The panel was initially mined to less than-final dimensions and later trimmed to specification. Mining was complete by February 2008. Waste emplacement was conducted from March 2009 through July 2011. Isolation walls were completed in November 2011. Instrumentation and regular observations will continue in the accessible area up to the isolation walls.

Panel 6 mining began in June 2008. The panel was initially mined to less- than-final dimensions and later trimmed to specification. Mining was complete by April 2010. Waste emplacement began in March of 2011. As of the end of this reporting period, CH Waste was being emplaced in Panel 6, Room 2 and RH Waste in Panel 6, Room 1.

Panel 7 mining activities began in April 2010 and were complete in January 2013.

6.2 Modifications to Excavations and Ground Control Activities

Routine maintenance and ground control activities in the form of trimming, scaling, rock bolt replacement, and installing wire mesh were performed on ribs, floor, and roof throughout accessible areas of the disposal panels.

The original floor of Panel 7 lay within two feet of a stiff polyhalite bed which rested atop a hard anhydrite bed. These beds, being stiffer than the adjacent salt, resisted the lateral loading imposed by creep deformation of the pillars and bow upward into the mined openings. To provide a stable floor for the lifetime of the panel, a wide channel was mined through the two beds, and is backfilled with run-of-mine salt. The backfilled salt will offer less resistance to the lateral loading and result in a more even uplift, rather than the severe bowing and fracturing that was experienced with the removed materials.

Geotechnical Analysis Report for July 2012 – June 2013
DOE/WIPP-14-3516, Vol. 1

Table 6-1 summarizes modifications and ground control activities performed in the disposal panels during this reporting period.

6.3 Instrumentation

There were no changes to the Panel 6 instrumentation layout. Convergence monitoring continued in all accessible areas up to the time that the waste stack front passed the instrument location. Remote monitoring of extensometers continues.

Panel 7 instrumentation consists of the following:

- Forty-nine vertical convergence points, distributed as fourteen each in the intake and exhaust drifts and three in each of the rooms; and
- Eleven wire extensometers, distributed as two in each of the intake and exhaust drifts and one in each of the rooms.

A schematic of the geomechanical instrumentation layout found in Panels 6 and 7 is shown in Figure 6-1.

Table 6- 1 Summary of Modifications and Ground Control Activities in the Waste Disposal Area July 1, 2012 to June 30, 2013	
Location	Work Activity
Panel 7	Installed lanyard system
Panel 7	Installed 4 ft mechanical roof bolts and chainlink mesh on rib/back junction
Panel 7	Began cutting out floor and backfilling with run-of-mill salt to address floor heave in March 2012
Panel 6, Room 1	Expanded existing 3-wide pattern of 12 ft resin anchored roof bolts to 7-wide pattern
Panel 6, S2750 from Room 1 to Room 4	Expanded existing 3-wide pattern of 12 ft resin anchored roof bolts to 7-wide pattern
Panel 6, S3650 From Room 1 to Room 4	Expanded existing 3-wide pattern of 12 ft resin anchored roof bolts to 7-wide pattern
S2750 from W170 to Panel 6, Room 1	Installed 14 ft resin anchored roof bolt pattern
Panel 7, S2180	Replaced broken 12 ft resin anchored roof bolts with 14 ft resin anchored roof bolts
Panel 6, Room 1	Replaced broken 12 ft resin anchored roof bolts with 14 ft resin anchored roof bolts
Panel 6 Room 1	Trim floor
S2750 Panel 6 Entry	Trim Floor

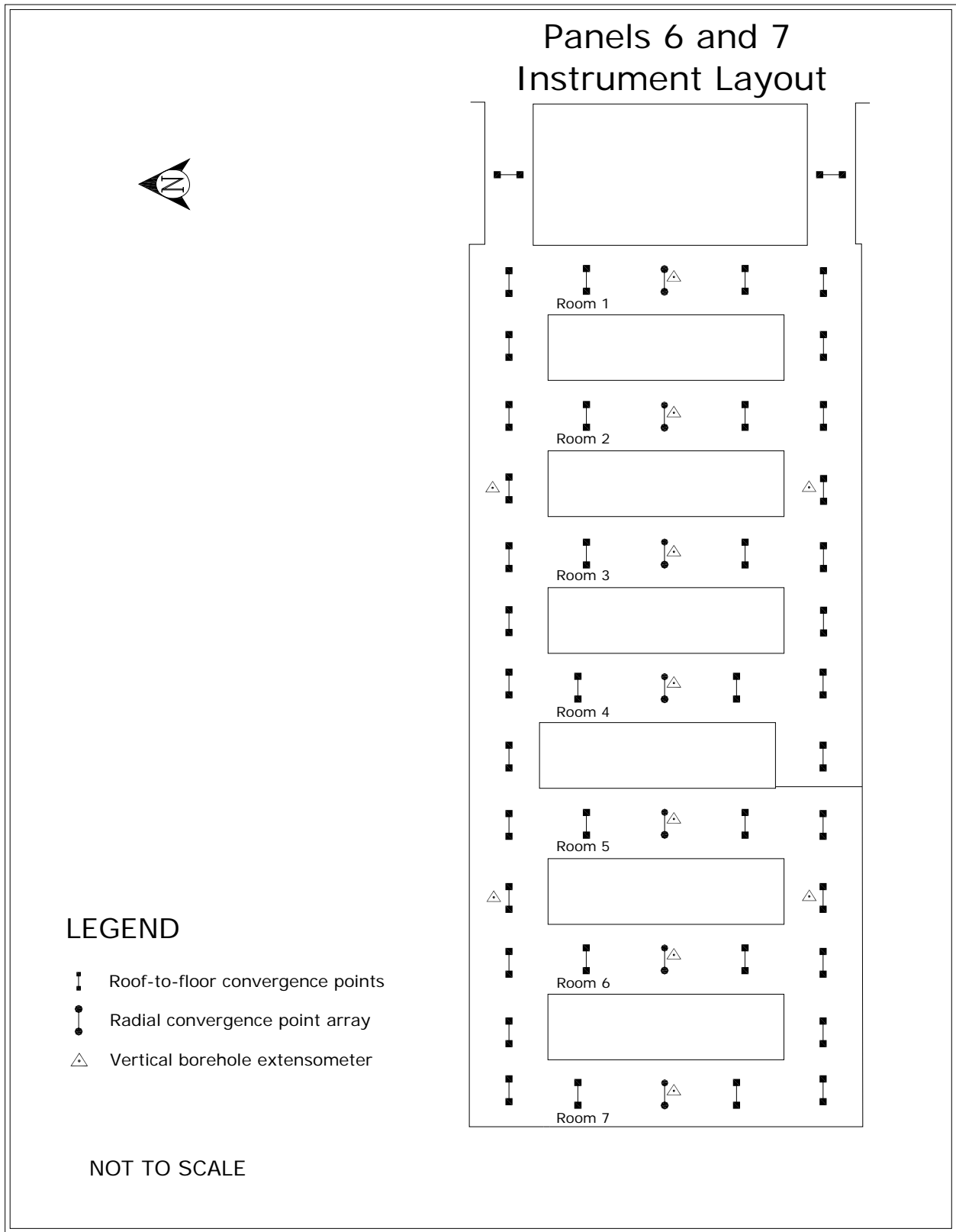

Figure 6 - 1 Location of Geomechanical Instruments in Panels 6 and 7

6.4 Excavation Performance

Waste handling activities in Panels 1-5 have been completed, and geomechanical monitoring inside these panels has been discontinued.

In accessible underground areas, horizontal and vertical convergence rates, calculated at the center of each of the rooms, were compared between this and the previous reporting period. Generally, convergence rates have declined from initial post-mining levels. Localized increases occur with seasonal creep trends, the presence of continuous anhydrite stringers, and coincident with adjacent mining activities. These increases are addressed, where necessary, with additional ground support selected for conditions prevailing at the specific location of installation.

6.5 Analysis of Extensometer and Convergence Point Data

Geomechanical instrumentation is installed in each disposal room and at select locations in the panel access drifts. As anticipated, these installations showed a general decrease in room closure rate and roof beam deformation with time. At some locations, deformation rates increased as roof sag and roof beam deterioration developed. Supplemental ground control support was installed in these areas and has subsequently reduced the observed rates.

Although Panels 1 through 5 are closed, convergence monitoring continues in the panel entries between E-300 and the explosion isolation walls (Panels 1 and 2) and substantial and isolation barriers (Panels 3 and 4). The exception is the Panel 4 intake drift (S3650) which is closed to access due to elevated volatile organic compound (VOC) levels. Monitoring data indicate generally steady long term trends. Incidences of short term acceleration are largely attributed to creep deformation of the pillars, which results in increasing lateral loading of the roof beam and the growth of separations along anhydrite stringers.

Panel 6 convergence data rates appear to be stabilized. Designed ground support consists of 5 foot-long resin anchored rock bolts, which provide a stiffening effect to the lower portion of the roof beam. Observation holes indicate that larger separations along anhydrite stringers were occurring above the 5 foot anchorage zone, the stress having been redirected to the upper portion of the roof beam. 12 foot resin anchored rock bolts were installed in the back to provide support for the entire roof beam. Individual bolts are replaced as necessary.

Geotechnical Analysis Report for July 2012 – June 2013
DOE/WIPP-14-3516, Vol. 1

Panel 7 mining activities, described in Section 6.2, were completed in January 2013. Initial mining placed the floor within two feet of a polyhalitic halite bed (designated PH-4) which sits atop a thick anhydrite bed designated MB-139. Horizontal stresses caused significant uplift and the floor was then mined down through MB-139 and backfilled with run of mine salt. Subsequent geomechanical monitoring indicates stable vertical convergence. Visual observations indicate a strong, stable floor. It is anticipated that the Panel 7 floor will remain viable throughout the life of the panel.

7.0 PERFORMANCE OF THE SALT DISPOSAL INVESTIGATIONS AND SALT DEFENSE DISPOSAL INVESTIGATIONS AREAS

This chapter describes the geomechanical performance of the SDI and SDDI areas (hereafter referred to as SDI). Development of the area began during the previous reporting period, in January 2012. When completed, most of the area will have nominal dimensions of 13 feet high and 16 feet wide.

7.1 Ground Control Program

Due to the relatively narrow drifts (nominally 16 feet across) and favorable mining horizon, ground control plans in the SDI area are confined to routine maintenance such as spot-bolting where localized drummy surface features develop. More substantial engineered ground control systems may be applied in the event that ongoing geomechanical monitoring and analysis of the area identify a need.

7.2 Instrumentation

Convergence point data are obtained by measuring the change in distance between fixed points anchored into the rock across an opening, either from rib to rib or from roof to floor. The measurement end-points constitute a "chord." Figure 5-1 shows typical convergence point array configurations along with typical chord designations.

7.3 Analysis of Convergence Point Data

As of this reporting period, forty-nine convergence points have produced preliminary data on the behavior of the SDI openings. As a rule, the area behaves as expected, with relatively high initial rates rapidly decreasing as the stresses redistribute to load the surrounding salt pillars.

7.4 Excavation Performance

One object of the SDI project is to observe the behavior of the salt in response to high heat sources emplaced within the mined openings. It is expected that the performance of these areas, in particular those nearest the experimental heat sources, will exhibit rapid creep movement. The necessity for ground control has not yet been determined. As the development of the area progresses and as the experiments begin to come on line, geotechnical observations will be closely analyzed for any need of external control.

8.0 GEOSCIENCE PROGRAM

The Geoscience Program confirms the suitability of the site through the collection of various geologic data and excavation characteristics from the underground. These include the inspection of open observation holes for fractures (separations) and offsets (lateral displacements) in roof beams and the mapping of fracture development on roof surfaces. Data collected through these activities support the design and evaluation of ground support systems.

During this reporting period, the following activities were performed:

- Observation hole inspections
- Fracture mapping

Fracture development in the roof is primarily caused by the concentration of compressive stresses in the roof beam and is influenced by the size and shape of the excavation and the stratigraphy in the immediate vicinity of the opening. In a thick roof beam, pillar deformations induce lateral compressive stresses into the immediate roof and floor. With time, the buildup of stress causes differential movement along stratigraphic boundaries. This differential movement is identified as offsets in observation holes and by the bends in failed rock bolts. Large strains associated with lateral movements can induce fracturing in the roof, which is frequently seen near the ribs; however, this process may take a long time (years) to develop.

At the upper repository horizon, clay or anhydrite stringers exert significant influence over the effective thickness of the roof beam. The presence of these stringers causes the roof beam to behave as a series of thin independent beams. Little or no tensile support is provided across the stringer interface. As horizontal end-loading continues, each beam can deflect downward causing a tensile fracture to develop along the bottom of the beam. These tensile fractures can develop in relatively new excavations soon after separation occurs along the stringer interface.

8.1 Observation Hole Inspections

Geotechnical observation holes are drilled at various locations throughout the underground facility. A location may contain one or more holes arranged in an array. These holes are drilled to depths that allow the monitoring of fracture development and offsetting and are inspected for the development of those features. Roof observation holes usually extend up past clays G and H (Figure 8-1 and Figure 8-2).

The clay seams nearest the excavation surfaces define the immediate roof beam. The roof beam is bounded by Clay G in most of the access drifts and Panels 1 and 2. Some areas, such as the Salt Shaft Station, portions of the E-0 and E-140 drifts, the south mains south of S-2620, and Panels 3, 4, 5, and 6 are excavated to Clay G and so have roof beams bounded by Clay H.

**Geotechnical Analysis Report for July 2012 – June 2013
DOE/WIPP-14-3516, Vol. 1**

The offset in an observation hole is determined by visually estimating the degree of occlusion. The direction of offset along clay seams is observed as the movement of the strata nearer to the observer relative to the strata farther away. Typically, the nearer strata move toward the center of the excavation (Figure 8-3 and Figure 8-4). Based on previous observations in the underground, the magnitude of offset is usually greater in holes located near ribs than in those located along excavation centerlines. Offsetting along the clay layers is observable until total offset is reached or visibility is obstructed by intervening offsets at other clay seams or fractures.

Observation holes are inspected for fractures, using an aluminum rod with a flattened steel wire probe attached to one end perpendicular to the rod (referred to as a "scratch rod"). Fractures and clay seams are located by moving the probe along the inside of the hole until it is snagged in one of these features. Depth to each feature is recorded, as is the magnitude of separations encountered. A fiber scope camera is available for use in addition to the scratch rod to visually document features of interest in a hole.

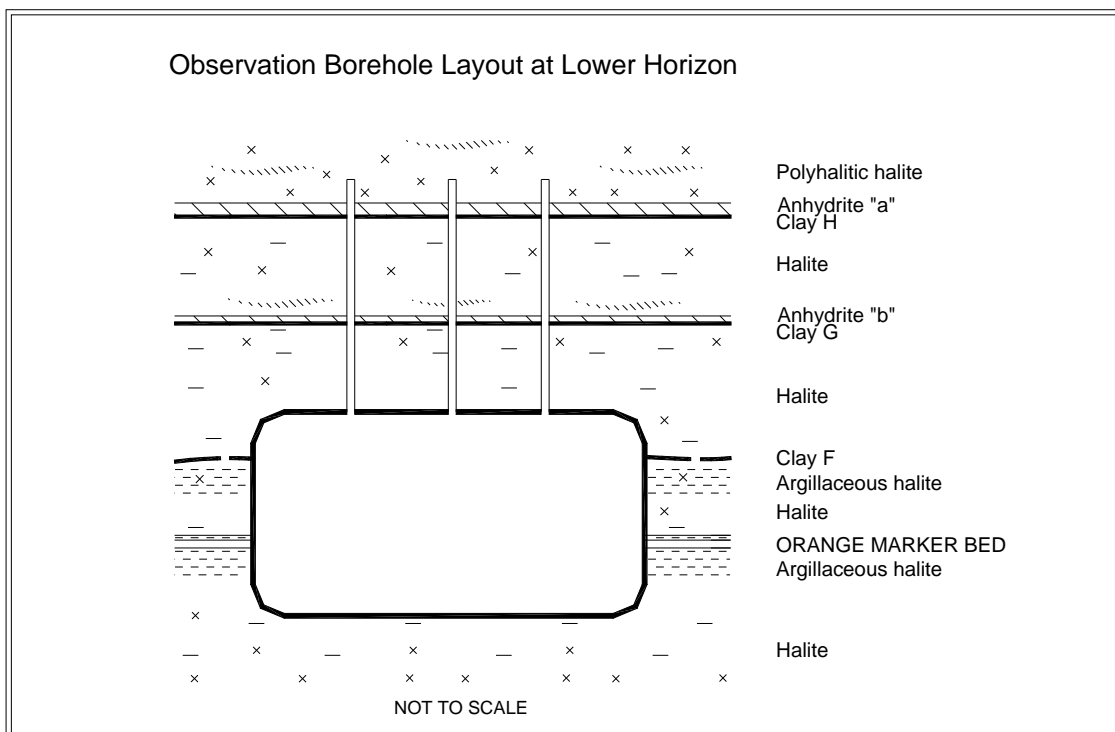

Figure 8 - 1 Example of Observation Hole Layout at Lower Horizon

**Geotechnical Analysis Report for July 2012 – June 2013
DOE/WIPP-14-3516, Vol. 1**

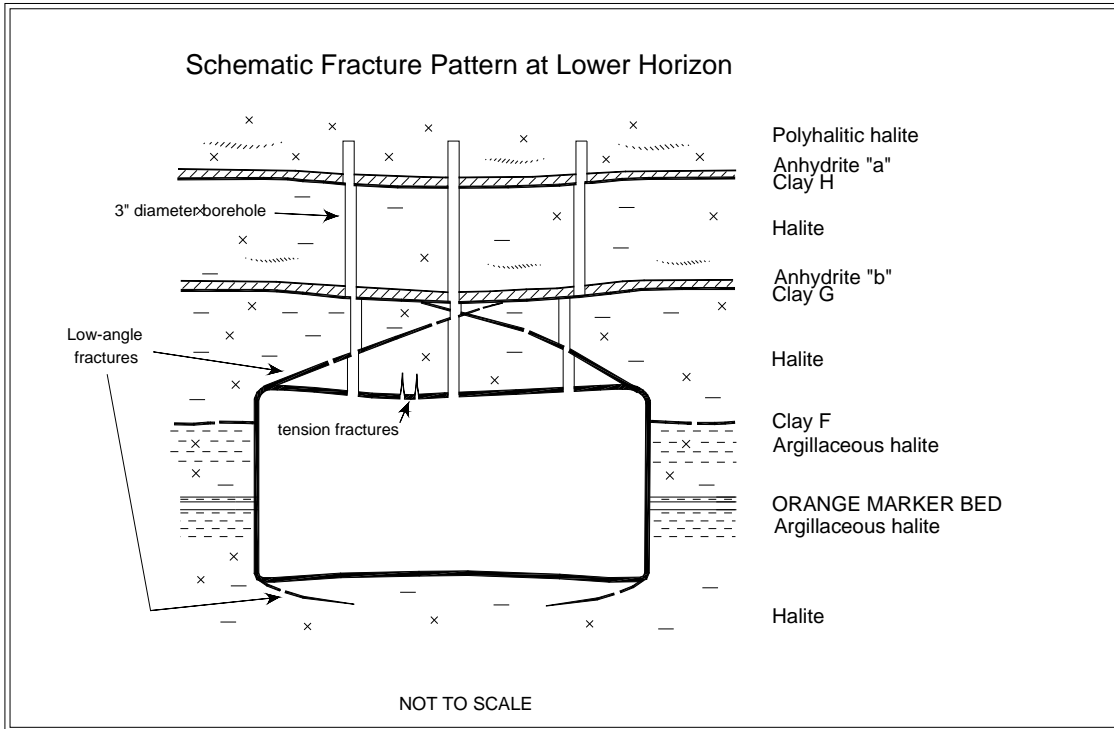

Figure 8 - 2 Typical Fracture Pattern at Lower Horizon

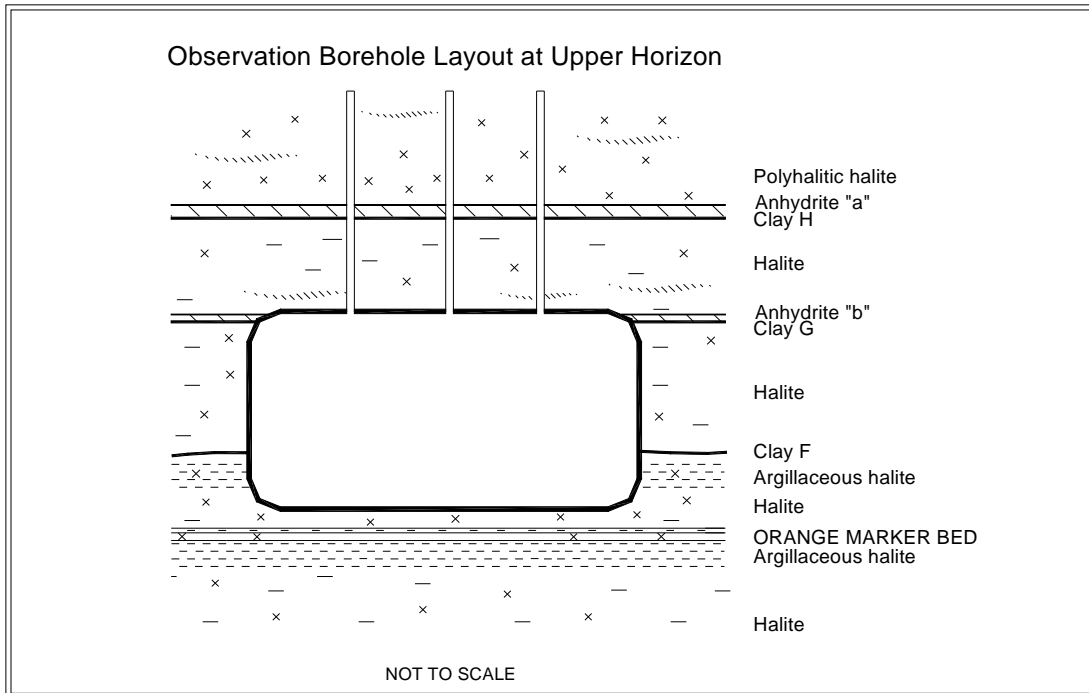

Figure 8 - 3 Example Observation Hole Layout at Upper Horizon

Geotechnical Analysis Report for July 2012 – June 2013
DOE/WIPP-14-3516, Vol. 1

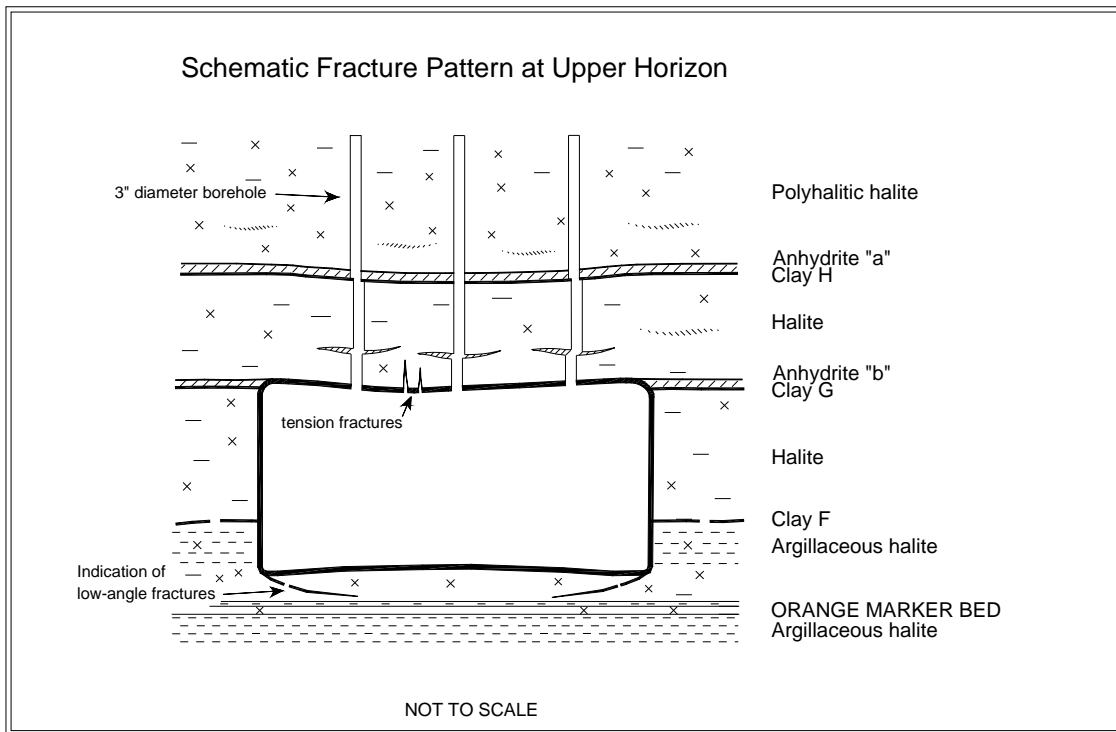

Figure 8 - 4 Typical Fracture Patterns at Upper Horizon

The separation and offset data observed in accessible observation holes in the back are presented in the supporting data document for this report. Nine accessible holes were monitored in Panel 6, forty-seven in Panel 7, and twenty-one in the E140 transport route between S400 and S2750. In Panel 6 and in E140, the greatest separations were associated with Clay H and Anhydrite "a". In addition, eight holes in Panel 6 and ten holes in E140 had separations associated with anhydrite stringers in the lower portion (first three feet) of the roof beam. Nine of nine holes in Panel 6 and thirty-three of the forty-seven holes in Panel 7, and sixteen of twenty-one holes in E140 showed some horizontal offset. In Panel 7, forty of forty-seven holes had separations associated with Clay G and Anhydrite "b".

8.2 Fracture Mapping

Routine mapping documents the progression of fractures in the roof exposed on the excavation surfaces of the drifts and rooms in the underground repository. The fracture surveys are generally performed on an annual basis, and the fracture maps are updated. The fracture maps facilitate the analysis of strain in the immediate roof-beam, because they document the development and propagation of fractures through time. The supporting data document contains fracture maps for Panels 6 and 7. During this reporting period, Panel 6 fractures were mapped in Room 1 and in S2750 between W377 and W527, and in S3080 between W370 and W519. All areas in Panel 7 were mapped.

9.0 SUMMARY

At the inception of WIPP, criteria were developed that address the design requirements (DOE, 1984). They pertained to all aspects of the mined facility and its operation as a pilot plant for the demonstration of technical and operational methods for permanent disposal of contact-handled and remote-handled TRU waste. In 1994, as the WIPP focus moved toward the permanent disposal of TRU waste, these design requirements were reassessed and replaced by a new set of requirements called system design descriptions. Table 9-1 shows the comparison of these design requirements with conditions actually observed in the underground from July 2012 through June 2013.

Normal drift and room maintenance continued during this reporting period with rib, roof, and floor scaling and trimming in various locations, and rock bolts and wire mesh installed as needed. Supplemental ground control systems consisting of resin-anchored bolts were installed in select locations. Some of these supplemental systems also included roof mats.

New geomechanical instrumentation was installed in Panel 7 and its access drifts, as well as in various locations throughout the repository to replace mined-out instruments. Panel 6 WEX instruments are monitored remotely for as long as possible. All accessible areas of the underground are connected to data-loggers or are monitored manually.

The *in situ* performance of the excavations generally continues to satisfy the appropriate design criteria, although specific areas are being identified where deterioration resulting from ageing must be addressed through routine maintenance and installation of engineered systems. This deterioration has been identified through the analysis of data acquired from geomechanical instrumentation and the Geoscience Program. If the planned life of some of the openings needs to be extended, changing the geometry of the access drifts (removing unstable roof beam or rib spalls, or milling the floor for added clearance), or additional ground control (roof removal, installing bolts, mesh, or straps) may be necessary. The ground conditions in the waste disposal area and associated waste transport routes continue to slowly deteriorate; however, routine ground control installations and maintenance continue to allow safe access in the underground facility.

In addition to underground instrumentation, qualitative assessments of fracture development are documented through mapping the underground repository and inspecting the observation holes. The information acquired from these programs provides early detection of ground deterioration, contributes to the understanding of the dynamic geomechanical processes in the WIPP underground, and aids in the design of effective ground control and support systems.

Geotechnical Analysis Report for July 2012 – June 2013
DOE/WIPP-14-3516, Vol. 1

Table 9 - 1 Comparison of Excavation Performance to System Design Requirements	
Requirement	Comments
"The lining shall be designed for a hydrostatic pressure. . . ."	Water pressure observed on piezometers located behind the shaft liners remains below design levels.
"The key shall be designed to resist the lateral pressure generated by salt creep."	Geomechanical data from the Waste Shaft indicate that the shaft key is minimally loaded and is structurally stable. Visual inspections of all shaft keys do not indicate any deterioration due to creep loading.
"The key shall be designed to retain the rock formation and will be provided with chemical seal rings and a water collection ring with drains to prevent water from flowing down the unlined shaft from the lining above."	Shaft inspection observations and instrumentation show no indication of instability due to salt dissolution. No water has been observed flowing along the rock-liner interface.
"The underground waste disposal facilities shall be designed to provide space and adequate access for the underground equipment and temporary storage space to support underground operations."	Geomechanical instrument data and visual observations indicate that the current design provides adequate access and storage and disposal space. Ground control maintenance is performed as necessary to maintain access.
"Entries and subentries to the underground disposal area and the experimental areas shall be provided and sized for personnel safety, adequate air flow, and space for equipment."	Deformation of excavation remains within the required limits. Normal periodic maintenance consisting of rock bolting, wire meshing, trimming, and scaling continue throughout the repository. Areas such as the waste transport route undergo periodic floor trims in order to maintain adequate operating height.
"Geomechanical instrumentation shall be provided to measure the cumulative deformation of the rock mass surrounding mined drifts. . . ."	Geomechanical instrumentation is operated and maintained to meet this requirement. This annual report provides a summary and analysis of the geomechanical data.

10.0 REFERENCES

ASTM, 2006, D6026-06, *Standard Practice for Using Significant Digits in Geotechnical Data*.

Public Law 96-164, *Department of Energy National Security and Military Applications of Nuclear Energy Authorization Act of 1980*.

Title 40 CFR Part 191, "Environmental Radiation Protection Standards for Management and Disposal of Spent Nuclear Fuel, High-Level and Transuranic Radioactive Wastes."

Title 40 CFR Part 194, "Criteria for the Certification and Re-certification of the Waste Isolation Pilot Plant's Compliance with the 40 CFR Part 191 Disposal Regulations."

**Geotechnical Analysis Report for July 2012 – June 2013
DOE/WIPP-14-3516, Vol. 1**

U.S. Environmental Protection Agency, 1998, "Criteria for the Certification and Recertification of the Waste Isolation Pilot Plant's Compliance with the Disposal Regulations: Certification Decision," Federal Register, Vol. 63, No. 95, pp. 27354, May 18, 1998, Washington, DC

Holt, R. M., and D. W. Powers, 1990, *Geologic Mapping of the Air Intake Shaft at the Waste Isolation Pilot Plant*, DOE/WIPP 90-051, Waste Isolation Pilot Plant, Carlsbad, New Mexico.

Holt, R. M., and D. W. Powers, 1984, *Geotechnical Activities in the Waste Handling Shaft, Waste Isolation Pilot Plant (WIPP) Project, Southeastern New Mexico*, WTSD TME 038, Waste Isolation Pilot Plant, Carlsbad, New Mexico.

New Mexico Environment Department (NMED), 2010, Waste Isolation Pilot Plant Hazardous Waste Facility Permit, NM4890139088-TSDF, Santa Fe, New Mexico.

Powers, D. W., and R. M. Holt, 1993, *The Upper Cenozoic Gatuña Formation of Southeastern New Mexico*, *New Mexico Geological Society Guidebook*, 44th Field Conference, Carlsbad Region, New Mexico and West Texas, D. W. Love et al., Eds., pp 271-282.

Powers, D. W., and R. M. Holt, 1995, *Gatuña Formation (Miocene to Pleistocene) Geology and Paleohydrology*, prepared for Westinghouse Waste Isolation Division by International Technology Corporation, Albuquerque, New Mexico.

Powers, D. W., S. J. Lambert, S. E. Shaffer, L. R. Hill, and W. D. Weart, Eds., 1978, *Geological Characterization Report, Waste Isolation Pilot Plant (WIPP) Site, Southeastern New Mexico, Vols. I and II*, SAND 78 1596; Sandia National Laboratories, Albuquerque, New Mexico.

U.S. Department of Energy (DOE), 2000, *Brine Generation Study, DOE/WIPP 00-2000, Waste Isolation Pilot Plant*, Carlsbad, New Mexico.

U.S. Department of Energy (DOE), 1986a, *Interim Geotechnical Field Data Report, DOE/WIPP 86-012*, Waste Isolation Pilot Plant, Carlsbad, New Mexico.

U.S. Department of Energy (DOE), 1986b, *Waste Isolation Pilot Plant Design Validation Final Report*, DOE/WIPP 86-010; Prepared by Bechtel National, Inc., for the U.S. Department of Energy, San Francisco, California.

U.S. Department of Energy (DOE), 1986c, *Geotechnical Activities in the Exhaust Shaft*, DOE/WIPP 86-008, Waste Isolation Pilot Plant, Carlsbad, New Mexico.

U.S. Department of Energy (DOE), 1985, *Quarterly Geotechnical Field Data Report*, DOE/WIPP-221, Waste Isolation Pilot Plant, Carlsbad, New Mexico.

Geotechnical Analysis Report for July 2012 – June 2013
DOE/WIPP-14-3516, Vol. 1

U.S. Department of Energy (DOE), 1984, *Design Criteria, Waste Isolation Pilot Plant (WIPP) Revised Mission Concept-IIA*, DOE/WIPP-071; Waste Isolation Pilot Plant, Carlsbad, New Mexico.

U.S. Department of Energy (DOE), 1983, *Summary of the Results of the Evaluation of the WIPP Site and Preliminary Design Validation Program*, DOE/WIPP-161; Waste Isolation Pilot Plant, Carlsbad, New Mexico.

Waste Isolation Pilot Plant

Geotechnical Analysis Report For July 2012 – June 2013

Supporting Data

U.S. Department of Energy

June 2014



This page was intentionally left blank.

Table of Contents

Table of Contents.....	3
List of Tables.....	4
1.0 Introduction.....	21
1.1 Instrumentation.....	21
1.2 Data Plot Explanation.....	22
1.3 Report Organization.....	22
2.0 Instrumentation Summary for Shafts.....	23
3.0 Instrumentation Summary for Shaft Stations.....	33
4.0 Instrumentation Summary for the Access Drifts.....	45
5.0 Instrumentation Summary for the Waste Disposal Area.....	203
6.0 Instrumentation Summary for the SDI Area.....	277
7.0 Geoscience Summary for the Waste Disposal Area.....	303
7.1 Borehole Inspections.....	303
7.2 Fracture Mapping.....	303

List of Tables

Table 2-1 Salt Handling Shaft Data Analysis.....	24
Table 3-1 Salt Handling Shaft Station Data Analysis	34
Table 3-2 Waste Shaft Station Data Analysis.....	38
Table 3-3 Air Intake Shaft Station Data Analysis.....	41
Table 4-1 Access Drifts Data Analysis	46
Table 5-1 Panel 1 Access Drifts Data Analysis	204
Table 5-2 Panel 2 Access Drifts Data Analysis	212
Table 5-3 Panel 3 Access Drift Data Analysis	214
Table 5-4 Panel 4 Access Drift Data Analysis	216
Table 5-5 Panel 5 Data Analysis	218
Table 5-6 Panel 6 Data Analysis	220
Table 5-7 Panel 7 Data Analysis	243
Table 6-1 SDI Data Analysis	278
Table 7-1 Observation Borehole Fractures and Offset Data Summary	304

List of Figures

Figure	Title	Page No.
--------	-------	----------

SHAFTS AND KEYS**Salt Handling Shaft**

Figure 2-1	Piezometers Salt Handling Shaft – Level 580 at the Forty-niner Member.....	26
Figure 2-2	Piezometers Salt Handling Shaft – Level 620 at the Magenta Dolomite Member.....	26
Figure 2-3	Piezometers Salt Handling Shaft – Level 691 at the Tamarisk Member ..	27
Figure 2-4	Piezometers Salt Handling Shaft – Level 802 at the Los Medaños Member.....	27
Figure 2-5	Piezometers Salt Handling Shaft – Level 850 at the Rustler-Salado Contact	28
Figure 2-6	Earth Pressure Cells Behind Shaft Key Salt Handling Shaft Key – Level 860	28
Figure 2-7	Spot-Welded Strain Gage Salt Handling Shaft Key – Level 856.3	29
Figure 2-8	Spot-Welded Strain Gages Salt Handling Shaft Key – Level 862.4	29
Figure 2-9	Embedment Strain Gages Salt Handling Shaft Key – Level 856.3	30
Figure 2-10	Embedment Strain Gages Salt Handling Shaft Key Level 856.3	30
Figure 2-11	Embedment Strain Gage Salt Handling Shaft Key Level 862.4	31
Figure 2-12	Embedment Strain Gage Salt Handling Shaft Key – Level 862.4	31

SHAFT STATIONS**Salt Handling Shaft Station**

Figure 3-1	Convergence Point Array Salt Handling Shaft Station at S18 – Centerline – Roof to Floor	35
Figure 3-2	Convergence Point Array Salt Handling Shaft Station at S18 – Quarter-Points – Roof to Floor	35
Figure 3-3	Convergence Point Array Salt Handling Shaft Station at S30 – Roof to Floor.....	36
Figure 3-4	Convergence Point Array Salt Handling Shaft Station at S65 – Roof to Floor.....	36
Figure 3-5	Extensometer 51X-GE-001026-2 Salt Handling Shaft Station at S30 – Roof	37
Figure 3-6	Extensometer 51X-GE-001027-2 Salt Handling Shaft Station at S60 – Roof	37

Waste Shaft Station

Figure 3-7	Extensometer 51X-GE-00268 Waste Shaft Station at S400 W30 – Roof	39
------------	--	----

List of Figures

Figure	Title	Page No.
Waste Shaft Station (Continued)		
Figure 3-8	Extensometers 51X-GE-00404 and 51X-GE-00404-2 Waste Shaft Station at S400 E35 – Roof	39
Figure 3-9	Convergence Point Array Waste Shaft Station at S400-E32 – Rib to Rib 40	
Figure 3-10	Convergence Point Array Waste Shaft Station at S400 E85 – Rib to Rib 40	
Air Intake Shaft Station		
Figure 3-11	Extensometer 41X-GE-00122 Air Intake Shaft Station at S65 – Roof	42
Figure 3-12	Extensometer 41X-GE-00123 Air Intake Shaft Station at N93 – Roof	42
Figure 3-13	Rock Bolt Load Cells Air Intake Shaft Station Brow – South Side Roof Bolts Set 1	43
Figure 3-14	Rock Bolt Load Cells Air Intake Shaft Station Brow – South Side Roof Bolts Set 2	43
Figure 3-15	Rock Bolt Load Cells Air Intake Shaft Station Brow – North Side Roof Bolts Set 1	44
Figure 3-16	Rock Bolt Load Cells Air Intake Shaft Station Brow – North Side Roof Bolts Set 2	44
Access Drifts		
Figure 4-1	Extensometer 51X-GE-00355 E0 N300 – Roof	63
Figure 4-2	Extensometer 51X-GE-00353 E0 N626 – Roof	63
Figure 4-3	Extensometer 51X-GE-00352 E0 N940 – Roof	64
Figure 4-4	Extensometer 51X-GE-00361 E0 N1266 – Roof	64
Figure 4-5	Extensometer 51X-GE-00105-3 – E140 N150 Roof	65
Figure 4-6	Extensometer 51X-GE-00364 E140 N1266 – Roof	65
Figure 4-7	Extensometer 51X-GE-00372 E140 S146 – Roof.....	66
Figure 4-8	Extensometer 51X-GE-00472 E140 S1000 – Roof.....	66
Figure 4-9	Extensometer 51X-GE-00464 E140 S1025 – Roof.....	67
Figure 4-10	Extensometer 51X-GE-00333 E140 S1075 – Roof.....	67
Figure 4-11	Extensometers 51X-GE-00428 and 51X-GE-00428-2 E140 S1150 – Roof	68
Figure 4-12	Extensometer 51X-GE-00335 E140 S1300 – Roof.....	68
Figure 4-13	Extensometer 51X-GE-00429 E140 S1450 – Roof.....	69
Figure 4-14	Extensometer 51X-GE-00430 E140 S1669 – Roof.....	69
Figure 4-15	Extensometer 51X-GE-00431 E140 S1775 – Roof.....	70
Figure 4-16	Extensometer 51X-GE-00432 E140 S1850 – Roof.....	70
Figure 4-17	Extensometers 51X-GE-00433 and 51X-GE-00433-2 E140 S2065 – Roof	71
Figure 4-18	Extensometer 51X-GE-00434 E140 S2265 – Roof.....	71
Figure 4-19	Extensometer 41X-GE-00435 E140 S2350 E140 S2350 – Roof.....	72
Figure 4-20	Extensometer 41X-GE-00437 E140 S2635 – Roof.....	72
Figure 4-21	Extensometer 51X-GE-00492 E140 S2750 – Roof.....	73

List of Figures

Figure	Title	Page No.
Access Drifts (Continued)		
Figure 4-22	Extensometers 51X-GE-00367, 51X-GE-00367-2 and 51X-GE-00439 E140 S2916 – Roof	73
Figure 4-23	Extensometer 51X-GE-00396 E140 S3493 – Roof.....	74
Figure 4-24	Extensometer 51X-GE-00373 E300 N1341 – Roof	74
Figure 4-25	Extensometer 51X-GE-00388 E300 N1266 – Roof	75
Figure 4-26	Extensometer 51X-GE-00374 E300 N1186 – Roof	75
Figure 4-27	Extensometer 51X-GE-00474 S1000 E120 – Roof.....	76
Figure 4-28	Extensometer 51X-GE-00473 S1000 E160 – Roof.....	76
Figure 4-29	Extensometer 51X-GE-00462 S1300 E120 – Roof.....	77
Figure 4-30	Extensometer 51X-GE-00463 S1300 E160 – Roof.....	77
Figure 4-31	Extensometer 51X-GE-00442 S1600 E120 – Roof.....	78
Figure 4-32	Extensometers 51X-GE-00500 and 51X-GE-00502 S2750 W93 – Roof	78
Figure 4-33	Extensometers 51X-GE-00501and 51X-GE-00501-2 S2750 W285 – Roof	79
Figure 4-34	Extensometer 51X-GE-00415 W170 S2998 – Roof.....	79
Figure 4-35	Extensometer 51X-GE-00490 W30 S2750 – Roof.....	80
Figure 4-36	Convergence Point Array Core Storage Library – Roof to Floor	80
Figure 4-37	Convergence Point Array E0 N75 – All Chords	81
Figure 4-38	Convergence Point Array E0 N225 – All Chords	81
Figure 4-39	Convergence Point Array E0 N300 – All Chords	82
Figure 4-40	Convergence Point Array E0 N460 – Roof to Floor	82
Figure 4-41	Convergence Point Array E0 N562 – All Chords	83
Figure 4-42	Convergence Point Array E0 N626 – Roof to Floor	83
Figure 4-43	Convergence Point Array E0 N686 – All Chords	84
Figure 4-44	Convergence Point Array E0 N780 – Roof to Floor	84
Figure 4-45	Convergence Point Array E0 N940 – All Chords	85
Figure 4-46	Convergence Point Array E0 N1100 – Roof to Floor	85
Figure 4-47	Convergence Point Array E0 N1266 – All Chords	86
Figure 4-48	Convergence Point Array E140 N5 – All Chords	86
Figure 4-49	Convergence Point Array E140 N150 – Roof to Floor	87
Figure 4-50	Convergence Point Array E140 N220 – Roof to Floor	87
Figure 4-51	Convergence Point Array E140 N355 – All Chords	88
Figure 4-52	Convergence Point Array E140 N460 – Roof to Floor	88
Figure 4-53	Convergence Point Array E140 N562 – All Chords	89
Figure 4-54	Convergence Point Array E140 N626 – All Chords	89
Figure 4-55	Convergence Point Array E140 N686 – All Chords	90
Figure 4-56	Convergence Point Array E140 N780 – Roof to Floor	90
Figure 4-57	Convergence Point Array E140 N940/N952 – All Chords.....	91
Figure 4-58	Convergence Point Array E140 N1100 – Roof to Floor	91
Figure 4-59	Convergence Point Array E140 N1266 – All Chords	92
Figure 4-60	Convergence Point Array E140 N1420 – Roof to Floor	92
Figure 4-61	Convergence Point Array E140 S90 – Roof to Floor	93
Figure 4-62	Convergence Point Array E140 S262 – All Chords.....	93

List of Figures

Figure	Title	Page No.
Access Drifts (Continued)		
Figure 4-63	Convergence Point Array E140 S460 – All Chords.....	94
Figure 4-64	Convergence Point Array E140 S550 – All Chords.....	94
Figure 4-65	Convergence Point Array E140 S700 – Roof to Floor – Centerline	95
Figure 4-66	Convergence Point Array E140 S700 – Roof to Floor – East Quarter Point	95
Figure 4-67	Convergence Point Array E140 S700 – Roof to Floor – West Quarter Point	96
Figure 4-68	Convergence Point Array E140 S850 – Roof to Floor	96
Figure 4-69	Convergence Point Array E140 S850 – Rib to Rib	97
Figure 4-70	Convergence Point Array E140 S1000 – Roof to Floor.....	97
Figure 4-71	Convergence Point Array E140 S1025 – Roof to Floor.....	98
Figure 4-72	Convergence Point Array E140 S1075 – Roof to Floor – Centerline	98
Figure 4-73	Convergence Point Array E140 S1075 – Roof to Floor – Quarter Points.....	99
Figure 4-74	Convergence Point Array E140 S1075 – Rib to Rib	99
Figure 4-75	Convergence Point Array E140 S1150 – Roof to Floor – Centerline	100
Figure 4-76	Convergence Point Array E140 S1150 – Roof to Floor – East Quarter Point	100
Figure 4-77	Convergence Point Array E140 S1150 – Rib to Rib	101
Figure 4-78	Convergence Point Array E140 S1150 – Roof to Floor – West Quarter Point	101
Figure 4-79	Convergence Point Array E140 S1225 – Roof to Floor Centerline and Rib to Rib.....	102
Figure 4-80	Convergence Point Array E140 S1225 – Roof to Floor – Quarter Points.....	102
Figure 4-81	Convergence Point Array E140 S1300 – Roof to Floor.....	103
Figure 4-82	Convergence Point Array E140 S1375/S1378 – Roof to Floor – Centerline	103
Figure 4-83	Convergence Point Array E140 S1375/S1378 – Roof to Floor – Quarter Points.....	104
Figure 4-84	Convergence Point Array E140 S1375/S1378 – Rib to Rib	104
Figure 4-85	Convergence Point Array E140 S1450/S1456 – Roof to Floor – Centerline	105
Figure 4-86	Convergence Point Array E140 S1450/S1456 – Roof to Floor – East Quarter Point	105
Figure 4-87	Convergence Point Array E140 S1450/S1456 – Rib to Rib Quarter Points.....	106
Figure 4-88	Convergence Point Array E140 S1450/S1456 – Roof to Floor – West Quarter Point	106
Figure 4-89	Convergence Point Array E140 S1456/S1450 – Rib to Rib – Mid-Height	107

List of Figures

Figure	Title	Page No.
Access Drifts (Continued)		
Figure 4-90	Convergence Point Array E140 S1525/S1534 – Roof to Floor – Centerline and Rib to Rib.....	107
Figure 4-91	Convergence Point Array E140 S1525/S1534 – Roof to Floor – East Quarter Point	108
Figure 4-92	Convergence Point Array E140 S1525/S1534 – Roof to Floor – West Quarter Point	108
Figure 4-93	Convergence Point Array E140 S1600 – Roof to Floor.....	109
Figure 4-94	Convergence Point Array E140 S1687 – Roof to Floor – Centerline and Rib to Rib.....	109
Figure 4-95	Convergence Point Array E140 S1687 – Roof to Floor – Quarter Points.....	110
Figure 4-96	Convergence Point Array E140 S1775 – Roof to Floor – Centerline	110
Figure 4-97	Convergence Point Array E140 S1775 – Roof to Floor – Quarter Points.....	111
Figure 4-98	Convergence Point Array E140 S1775 – Rib to Rib	111
Figure 4-99	Convergence Point Array E140 S1862 – Roof to Floor – Centerline and Rib to Rib.....	112
Figure 4-100	Convergence Point Array E140 S1862 – Roof to Floor – Quarter Points.....	112
Figure 4-101	Convergence Point Array E140 S1950 – Roof to Floor.....	113
Figure 4-102	Convergence Point Array E140 S2007 – Roof to Floor.....	113
Figure 4-103	Convergence Point Array E140 S2065 – All Chords.....	114
Figure 4-104	Convergence Point Array E140 S2122 – Roof to Floor.....	114
Figure 4-105	Convergence Point Array E140 S2275 – All Chords.....	115
Figure 4-106	Convergence Point Array E140 S2350 – All Chords.....	115
Figure 4-107	Convergence Point Array E140 S2425 – All Chords.....	116
Figure 4-108	Convergence Point Array E140 S2520 – Roof to Floor.....	116
Figure 4-109	Convergence Point Array E140 S2634 – All Chords.....	117
Figure 4-110	Convergence Point Array E140 S2750 – Roof to Floor.....	117
Figure 4-111	Convergence Point Array E140 S2833 – All Chords.....	118
Figure 4-112	Convergence Point Array E140 S2915 – All Chords.....	118
Figure 4-113	Convergence Point Array E140 S2998 – All Chords.....	119
Figure 4-114	Convergence Point Array E140 S3080 – Roof to Floor.....	119
Figure 4-115	Convergence Point Array E140 S3195 – All Chords.....	120
Figure 4-116	Convergence Point Array E140 S3295 – Roof to Floor.....	120
Figure 4-117	Convergence Point Array E140 S3325 – Roof to Floor.....	121
Figure 4-118	Convergence Point Array E140 S3395 – All Chords.....	121
Figure 4-119	Convergence Point Array E140 S3480 – All Chords.....	122
Figure 4-120	Convergence Point Array E140 S3565 – All Chords.....	122
Figure 4-121	Convergence Point Array E140 S3650 – Roof to Floor.....	123
Figure 4-122	Convergence Point Array E300 N45 – All Chords	123
Figure 4-123	Convergence Point Array E300 N170 – All Chords	124
Figure 4-124	Convergence Point Array E300 N250 – Roof to Floor	124

List of Figures

Figure	Title	Page No.
Access Drifts (Continued)		
Figure 4-125	Convergence Point Array E300 N1253/N1262– Roof to Floor	125
Figure 4-126	Convergence Point Array E300 N1325/N1341 – Roof to Floor	125
Figure 4-127	Convergence Point Array E300 S45 – All Chords	126
Figure 4-128	Convergence Point Array E300 S90 – Roof to Floor	126
Figure 4-129	Convergence Point Array E300 S250 – All Chords	127
Figure 4-130	Convergence Point Array E300 S700 – Roof to Floor	127
Figure 4-131	Convergence Point Array E300 S850 – All Chords	128
Figure 4-132	Convergence Point Array E300 S1000 – Roof to Floor	128
Figure 4-133	Convergence Point Array E300 S1150 – Roof to Floor	129
Figure 4-134	Convergence Point Array E300 S1150 – Roof to Floor – Quarter Points	129
Figure 4-135	Convergence Point Array E300 S1150 – Rib to Rib	130
Figure 4-136	Convergence Point Array E300 S1300 – Roof to Floor	130
Figure 4-137	Convergence Point Array E300 S1450 – All Chords	131
Figure 4-138	Convergence Point Array E300 S1687 – All Chords	131
Figure 4-139	Convergence Point Array E300 S1775 – All Chords	132
Figure 4-140	Convergence Point Array E300 S1862 – All Chords	132
Figure 4-141	Convergence Point Array E300 S2065 – All Chords	133
Figure 4-142	Convergence Point Array E300 S2275 – All Chords	133
Figure 4-143	Convergence Point Array E300 S2350 – All Chords	134
Figure 4-144	Convergence Point Array E300 S2425 – All Chords	134
Figure 4-145	Convergence Point Array E300 S2634 – All Chords	135
Figure 4-146	Convergence Point Array E300 S2833 – All Chords	135
Figure 4-147	Convergence Point Array E300 S2916 – All Chords	136
Figure 4-148	Convergence Point Array E300 S2998 – All Chords	136
Figure 4-149	Convergence Point Array E300 S3195 – All Chords	137
Figure 4-150	Convergence Point Array E300 S3480 – All Chords	137
Figure 4-151	Convergence Point Array N140 E90 – All Chords	138
Figure 4-152	Convergence Point Array N215 W500 – All Chords	138
Figure 4-153	Convergence Point Array N215 W620 – Roof to Floor	139
Figure 4-154	Convergence Point Array N250 E220 – All Chords	139
Figure 4-155	Convergence Point Array N300 W170 – All Chords	140
Figure 4-156	Convergence Point Array N460 E70 – All Chords	140
Figure 4-157	Convergence Point Array N780 E70 – All Chords	141
Figure 4-158	Convergence Point Array S90 W120 – All Chords	141
Figure 4-159	Convergence Point Array S90 W400 – All Chords	142
Figure 4-160	Convergence Point Array S90 W590 – All Chords	142
Figure 4-161	Convergence Point Array S90 W620 – Roof to Floor	143
Figure 4-162	Convergence Point Array S90 W770 – All Chords	143
Figure 4-163	Convergence Point Array S90 W905 – Roof to Floor	144
Figure 4-164	Convergence Point Array S105 W920 – Roof to Floor	144
Figure 4-165	Convergence Point Array S700 E55 – All Chords	145
Figure 4-166	Convergence Point Array S700 E180 – All Chords	145
Figure 4-167	Convergence Point Array S700 E205 – All Chords	146

List of Figures

Figure	Title	Page No.
Access Drifts (Continued)		
Figure 4-168	Convergence Point Array S700 W98 – Roof to Floor.....	146
Figure 4-169	Convergence Point Array S1000 E58 – All Chords.....	147
Figure 4-170	Convergence Point Array S1000 E120 – Roof to Floor.....	147
Figure 4-171	Convergence Point Array S1000 E160 – Roof to Floor.....	148
Figure 4-172	Convergence Point Array S1000 W98 – All Chords.....	148
Figure 4-173	Convergence Point Array S1300 E24 – Roof to Floor.....	149
Figure 4-174	Convergence Point Array S1300 E120 – Roof to Floor.....	149
Figure 4-175	Convergence Point Array S1300 E160 – Roof to Floor.....	150
Figure 4-176	Convergence Point Array S1300 W100 – Roof to Floor.....	150
Figure 4-177	Convergence Point Array S1600 E110 – Roof to Floor.....	151
Figure 4-178	Convergence Point Array S1600 E170 – Roof to Floor.....	151
Figure 4-179	Convergence Point Array S1950 E113 – Roof to Floor.....	152
Figure 4-180	Convergence Point Array S1950 E281 – Roof to Floor.....	152
Figure 4-181	Convergence Point Array S1950 E284 – Roof to Floor.....	153
Figure 4-182	Convergence Point Array S2180 E55 – All Chords.....	153
Figure 4-183	Convergence Point Array S2180 E220 – All Chords.....	154
Figure 4-184	Convergence Point Array S2180 W100 – All Chords.....	154
Figure 4-185	Convergence Point Array S2520 E220 – All Chords.....	155
Figure 4-186	Convergence Point Array S2520 W100 – All Chords.....	155
Figure 4-187	Convergence Point Array S2750 E55 – All Chords.....	156
Figure 4-188	Convergence Point Array 2750 E220 – All Chords.....	156
Figure 4-189	Convergence Point Array 2750 E410 – All Chords.....	157
Figure 4-190	Convergence Point Array 2750 W93 – All Chords.....	157
Figure 4-191	Convergence Point Array S3080 E220 – All Chords.....	158
Figure 4-192	Convergence Point Array S3080 W100 – All Chords.....	158
Figure 4-193	Convergence Point Array S3310 E55 – All Chords.....	159
Figure 4-194	Convergence Point Array S3310 E220 – All Chords.....	159
Figure 4-195	Convergence Point Array S3310 W100 – All Chords.....	160
Figure 4-196	Convergence Point Array S3650 E55 – Roof to Floor.....	160
Figure 4-197	Convergence Point Array S3650 E220 – Roof to Floor.....	161
Figure 4-198	Convergence Point Array S3650 W100 – All Chords.....	161
Figure 4-199	Convergence Point Array W30 S120 – Roof to Floor.....	162
Figure 4-200	Convergence Point Array W30 S250 – All Chords.....	162
Figure 4-201	Convergence Point Array W30 S400 – Roof to Floor.....	163
Figure 4-202	Convergence Point Array W30 S500 – All Chords.....	163
Figure 4-203	Convergence Point Array W30 S700 – Roof to Floor.....	164
Figure 4-204	Convergence Point Array W30 S850 – Roof to Floor – Centerline.....	164
Figure 4-205	Convergence Point Array W30 S850 – Roof to Floor – Quarter Points.....	165
Figure 4-206	Convergence Point Array W30 S850 – Rib to Rib.....	165
Figure 4-207	Convergence Point Array W30 S1000 – Roof to Floor.....	166
Figure 4-208	Convergence Point Array W30 S1150 – Roof to Floor.....	166
Figure 4-209	Convergence Point Array W30 S1300 – Roof to Floor.....	167

List of Figures

Figure	Title	Page No.
Access Drifts (Continued)		
Figure 4-210	Convergence Point Array W30 S1453 – All Chords	167
Figure 4-211	Convergence Point Array W30 S1600 – Roof to Floor	168
Figure 4-212	Convergence Point Array W30 S1775 – All Chords	168
Figure 4-213	Convergence Point Array W30 S1950 – Roof to Floor	169
Figure 4-214	Convergence Point Array W30 S2067 – All Chords	169
Figure 4-215	Convergence Point Array W30 S2275 – All Chords	170
Figure 4-216	Convergence Point Array W30 S2350 – All Chords	170
Figure 4-217	Convergence Point Array W30 S2425 – All Chords	171
Figure 4-218	Convergence Point Array W30 S2520 – Roof to Floor	171
Figure 4-219	Convergence Point Array W30 S2685 – All Chords	172
Figure 4-220	Convergence Point Array W30 S2750 – Roof to Floor	172
Figure 4-221	Convergence Point Array W30 S2833 – All Chords	173
Figure 4-222	Convergence Point Array W30 S2916 – All Chords	173
Figure 4-223	Convergence Point Array W30 S2998 – All Chords	174
Figure 4-224	Convergence Point Array W30 S3080 – Roof to Floor	174
Figure 4-225	Convergence Point Array W30 S3195 – All Chords	175
Figure 4-226	Convergence Point Array W30 S3310 – Roof to Floor	175
Figure 4-227	Convergence Point Array W30 S3395 – All Chords	176
Figure 4-228	Convergence Point Array W30 S3650 – Roof to Floor	176
Figure 4-229	Convergence Point Array W170 N150 – Roof to Floor	177
Figure 4-230	Convergence Point Array W170 S5 – All Chords	177
Figure 4-231	Convergence Point Array W170 S90 – Roof to Floor	178
Figure 4-232	Convergence Point Array W170 S232 – All Chords	178
Figure 4-233	Convergence Point Array W170 S400 – Roof to Floor	179
Figure 4-234	Convergence Point Array W170 S560 – All Chords	179
Figure 4-235	Convergence Point Array W170 S700 – Roof to Floor	180
Figure 4-236	Convergence Point Array W170 S850 – Roof to Floor – Centerline	180
Figure 4-237	Convergence Point Array W170 S850 – Roof to Floor – East Quarter Point	181
Figure 4-238	Convergence Point Array W170 S850 – Rib to Rib	181
Figure 4-239	Convergence Point Array W170 S850 – Roof to Floor – West Quarter Point	182
Figure 4-240	Convergence Point Array W170 S1000 – Roof to Floor	182
Figure 4-241	Convergence Point Array W170 S1150 – Roof to Floor	183
Figure 4-242	Convergence Point Array W170 S1150 – Rib to Rib	183
Figure 4-243	Convergence Point Array W170 S1300 – Roof to Floor	184
Figure 4-244	Convergence Point Array W170 S1445 – All Chords	184
Figure 4-245	Convergence Point Array W170 S1600 – Roof to Floor	185
Figure 4-246	Convergence Point Array W170 S1779 – All Chords	185
Figure 4-247	Convergence Point Array W170 S1950 – Roof to Floor	186
Figure 4-248	Convergence Point Array W170 S2060 – All Chords	186
Figure 4-249	Convergence Point Array W170 S2180 – Roof to Floor	187
Figure 4-250	Convergence Point Array W170 S2275 – All Chords	187

List of Figures

Figure	Title	Page No.
Access Drifts (Continued)		
Figure 4-251	Convergence Point Array W170 S2350 – All Chords.....	188
Figure 4-252	Convergence Point Array W170 S2425 – All Chords.....	188
Figure 4-253	Convergence Point Array W170 S2520 – Roof to Floor.....	189
Figure 4-254	Convergence Point Array W170 S2685 – All Chords.....	189
Figure 4-255	Convergence Point Array W170 S2833 – All Chords.....	190
Figure 4-256	Convergence Point Array W170 S2916 – All Chords.....	190
Figure 4-257	Convergence Point Array W170 S2998 – All Chords.....	191
Figure 4-258	Convergence Point Array W170 S3080 – Roof to Floor.....	191
Figure 4-259	Convergence Point Array W170 S3195 – All Chords.....	192
Figure 4-260	Convergence Point Array W170 S3310 – Roof to Floor.....	192
Figure 4-261	Convergence Point Array W170 S3395 – All Chords.....	193
Figure 4-262	Convergence Point Array W170 S3480 – All Chords.....	193
Figure 4-263	Convergence Point Array W170 S3565 – All Chords.....	194
Figure 4-264	Convergence Point Array W170 S3650 – Roof to Floor.....	194
Figure 4-265	Joint Meter S1950 E300 Overcast.....	195
Figure 4-266	Joint Meter E140 S1505.....	195
Figure 4-267	Joint Meter E140 S1529.....	196
Figure 4-268	Joint Meter E140 S1545.....	196
Figure 4-269	Joint Meter E140 S1795.....	197
Figure 4-270	Joint Meter E140 S2964.....	197
Figure 4-271	Rock Bolt Load Cells, Bolts 1-5 E140 N1266.....	198
Figure 4-272	Rock Bolt Load Cells, Bolts 6-9 E140 N1266.....	198
Figure 4-273	Rock Bolt Load Cells E140 S774 – S1023.....	199
Figure 4-274	Rock Bolt Load Cells E140 S910.....	199
Figure 4-275	Rock Bolt Load Cell E140 S1550.....	200
Figure 4-276	Rock Bolt Load Cell E140 S1775.....	200
Figure 4-277	Rock Bolt Load Cells E140 S2916.....	201
Figure 4-278	Rock Bolt Load Cell S1300 E120.....	201
Figure 4-279	Rock Bolt Load Cell S1300 E160.....	202
Figure 4-280	Rock Bolt Load Cell S1600 E150.....	202
Waste Disposal Area Panel 1		
Figure 5-1	Convergence Point Array S1600 E311 – All Chords.....	205
Figure 5-2	Convergence Point Array S1600 E332 – All Chords.....	205
Figure 5-3	Convergence Point Array S1600 E357 – All Chords.....	206
Figure 5-4	Convergence Point Array S1600 E382 – All Chords.....	206
Figure 5-5	Convergence Point Array S1600 E407 – Roof to Floor.....	207
Figure 5-6	Convergence Point Array S1600 E432 – All Chords.....	207
Figure 5-7	Convergence Point Array S1600 E453 – All Chords.....	208
Figure 5-8	Convergence Point Array S1950 E311 – All Chords.....	208
Figure 5-9	Convergence Point Array S1950 E332 – All Chords.....	209
Figure 5-10	Convergence Point Array S1950 E357 – All Chords.....	209
Figure 5-11	Convergence Point Array S1950 E382 – All Chords.....	210

List of Figures

Figure	Title	Page No.
Waste Disposal Area Panel 1 (Continued)		
Figure 5-12	Convergence Point Array S1950 E407 – Roof to Floor.....	210
Figure 5-13	Convergence Point Array S1950 E407 – Rib to Rib	211
Figure 5-14	Convergence Point Array S1950 E432 – All Chords.....	211
Waste Disposal Area Panel 2		
Figure 5-15	Convergence Point Array S2180 E410 – All Chords.....	213
Figure 5-16	Convergence Point Array S2520 E410 – All Chords.....	213
Waste Disposal Area Panel 3		
Figure 5-17	Convergence Point Array S2750 E410 – All Chords.....	215
Figure 5-18	Convergence Point Array S3080 E410 – All Chords.....	215
Waste Disposal Area Panel 4		
Figure 5-19	Convergence Point Array S3310 E410 – Roof to Floor.....	217
Waste Disposal Area Panel 5		
Figure 5-20	Convergence Point Array S3310 W285 – Roof to Floor.....	219
Figure 5-21	Convergence Point Array S3650 W285 – Roof to Floor.....	219
Waste Disposal Area Panel 6		
Figure 5-22	Extensometer 51X-GE-00501 and 51X-GE-00501-2 S2750 W285 – Roof	222
Figure 5-23	Extensometer 51X-GE-00413-2 S2750 W585 – Roof	222
Figure 5-24	Extensometer 51X-GE-00414 S2750 W985 – Roof.....	223
Figure 5-25	Extensometer 51X-GE-00403-2 Room 1, Panel 6 at W390 S2916 – Roof	223
Figure 5-26	Extensometer 51X-GE-00405-2 Room 2, Panel 6 at W520 S2916 – Room Center – Roof.....	224
Figure 5-27	Extensometer 51X-GE-00406 Room 3, Panel 6 at W660 S2916– Room Center – Roof.....	224
Figure 5-28	Extensometer 51X-GE-00407 Room 4, Panel 6 at W790 S2916 – Room Center – Roof.....	225
Figure 5-29	Extensometer 51X-GE-00408-2 Room 5, Panel 6 at W920 S2916– Room Center – Roof.....	225
Figure 5-30	Extensometer 51X-GE-00409 Room 6, Panel 6 at W1050 S2916 – Room Center – Roof.....	226
Figure 5-31	Extensometer 51X-GE-00410 Room 7, Panel 6 at W1190 S2916 – Room Center – Roof.....	226
Figure 5-32	Extensometer 51X-GE-00411 S3080 W585 – Roof.....	227
Figure 5-33	Extensometer 51X-GE-00412 S3080 W985 – Roof.....	227
Figure 5-34	Convergence Point Array S2750 W285 – Roof to Floor.....	228

List of Figures

Figure	Title	Page No.
Waste Disposal Area Panel 6 (Continued)		
Figure 5-35	Convergence Point Array S2750 W390 Intersection (Room 1, Panel 6) – Roof to Floor.....	228
Figure 5-36	Convergence Point Array S2750 W460 – Roof to Floor.....	229
Figure 5-37	Convergence Point Array S2750 W520 Intersection (Room 2, Panel 6) – Roof to Floor.....	229
Figure 5-38	Convergence Point Array S2750 W590 – Roof to Floor.....	230
Figure 5-39	Convergence Point Array S2750 W660 Intersection (Room 3 Panel 6) – Roof to Floor.....	230
Figure 5-40	Convergence Point Array S2750 W725 – Roof to Floor.....	231
Figure 5-41	Convergence Point Array S2750 W790 Intersection (Room 4, Panel 6) – Roof to Floor.....	231
Figure 5-42	Convergence Point Array S2750 W885 – Roof to Floor.....	232
Figure 5-43	Convergence Point Array Room 1, Panel 6 at W390 S2833 – Roof to Floor.....	232
Figure 5-44	Convergence Point Array Room 1, Panel 6 at W390 S2916 – Room Center – All Chords.....	233
Figure 5-45	Convergence Point Array Room 1, Panel 6 at W390 S2998 – Roof to Floor.....	233
Figure 5-46	Convergence Point Array Room 2, Panel 6 at W520 S2833 – Roof to Floor.....	234
Figure 5-47	Convergence Point Array Room 2, Panel 6 at W520 S2916– Room Center – All Chords.....	234
Figure 5-48	Convergence Point Array Room 2, Panel 6 at W520 S2998 – Roof to Floor.....	235
Figure 5-49	Convergence Point Array Room 3, Panel 6 at W660 S2833 – Roof to Floor.....	235
Figure 5-50	Convergence Point Array Room 3, Panel 6 at W660 S2916 – Room Center – All Chords.....	236
Figure 5-51	Convergence Point Array Room 3, Panel 6 at W660 S2998 – Roof to Floor.....	236
Figure 5-52	Convergence Point Array Room 4, Panel 6 at W790 S2833 – Roof to Floor.....	237
Figure 5-53	Convergence Point Array Room 4, Panel 6 at W790 S2916 – Room Center – All Chords.....	237
Figure 5-54	Convergence Point Array Room 4, Panel 6 at W790 S2998 – Roof to Floor.....	238
Figure 5-55	Convergence Point Array S3080 W285 – Roof to Floor.....	238
Figure 5-56	Convergence Point Array S3080 W390 Intersection (Room 1, Panel 6) – Roof to Floor.....	239
Figure 5-57	Convergence Point Array S3080 W460 – Roof to Floor.....	239
Figure 5-58	Convergence Point Array S3080 W520 Intersection (Room 2, Panel 6) – Roof to Floor.....	240
Figure 5-59	Convergence Point Array S3080 W585 – Roof to Floor.....	240

List of Figures

Figure	Title	Page No.
Waste Disposal Area Panel 6 (Continued)		
Figure 5-60	Convergence Point Array S3080 W660 Intersection (Room 3, Panel 6) – Roof to Floor	241
Figure 5-61	Convergence Point Array S3080 W725 – Roof to Floor.....	241
Figure 5-62	Convergence Point Array S3080 W790 Intersection (Room 4, Panel 6) – Roof to Floor	242
Waste Disposal Area Panel 7		
Figure 5-63	Extensometer 51X-GE-00416 S2180 W585 – Roof.....	246
Figure 5-64	Extensometer 51X-GE-00417 S2180 W985 – Roof.....	246
Figure 5-65	Extensometer 51X-GE-00425 Room 1, Panel 7 at W390 S2350 – Room Center – Roof.....	247
Figure 5-66	Extensometer 51X-GE-00426 Room 2, Panel 7 at W520 S2350 – Room Center – Roof.....	247
Figure 5-67	Extensometer 51X-GE-00418 Room 3, Panel 7 at W660 S2350 – Room Center – Roof.....	248
Figure 5-68	Extensometer 51X-GE-00419 Room 4, Panel 7 at W790 S2350 – Room Center – Roof.....	248
Figure 5-69	Extensometer 51X-GE-00420 Room 5, Panel 7 at W920 S2350 – Room Center – Roof.....	249
Figure 5-70	Extensometer 51X-GE-00421 Room 6, Panel 7 at W1050 S2350 – Room Center – Roof.....	249
Figure 5-71	Extensometer 51X-GE-00422 Room 7, Panel 7 at W1190 S2350 – Room Center – Roof.....	250
Figure 5-72	Extensometer 51X-GE-00423 S2520 W585 – Roof.....	250
Figure 5-73	Extensometer 51X-GE-00424 S2520 W985 – Roof.....	251
Figure 5-74	Convergence Point Array S2180 W285 – Roof to Floor.....	251
Figure 5-75	Convergence Point Array S2180 W390 Intersection (Room 1, Panel 7) – Roof to Floor.....	252
Figure 5-76	Convergence Point Array S2180 W460 – Roof to Floor.....	252
Figure 5-77	Convergence Point Array S2180 W520 Intersection (Room 2, Panel 7) – Roof to Floor.....	253
Figure 5-78	Convergence Point Array S2180 W585 – Roof to Floor.....	253
Figure 5-79	Convergence Point Array S2180 W660 Intersection (Room 3 Panel 7) – Roof to Floor.....	254
Figure 5-80	Convergence Point Array S2180 W725 – Roof to Floor.....	254
Figure 5-81	Convergence Point Array S2180 W790 Intersection (Room 4, Panel 7) – Roof to Floor.....	255
Figure 5-82	Convergence Point Array S2180 W885 – Roof to Floor.....	255
Figure 5-83	Convergence Point Array S2180 W920 Intersection (Room 5, Panel 7) – Roof to Floor.....	256
Figure 5-84	Convergence Point Array S2180 W985 – Roof to Floor.....	256
Figure 5-85	Convergence Point Array S2180 W1050 Intersection (Room 6, Panel 7) – Roof to Floor.....	257

List of Figures

Figure	Title	Page No.
Waste Disposal Area Panel 7 (Continued)		
Figure 5-86	Convergence Point Array S2180 W1120 – Roof to Floor.....	257
Figure 5-87	Convergence Point Array S2180 W1190 Intersection (Room 7, Panel 7) – Roof to Floor.....	258
Figure 5-88	Convergence Point Array Room 1, Panel 7 at W390 S2275 – Roof to Floor.....	258
Figure 5-89	Convergence Point Array Room 1, Panel 7 at W390 S2350– Room Center – All Chords.....	259
Figure 5-90	Convergence Point Array Room 1, Panel 7 at W390 S2425 – Roof to Floor.....	259
Figure 5-91	Convergence Point Array Room 2, Panel 7 at W520 S2275 – Roof to Floor.....	260
Figure 5-92	Convergence Point Array Room 2, Panel 7 at W520 S2350 – Room Center – All Chords.....	260
Figure 5-93	Convergence Point Array Room 2, Panel 7 at W520 S2425 – Roof to Floor.....	261
Figure 5-94	Convergence Point Array Room 3, Panel 7 at W660 S2275 – Roof to Floor.....	261
Figure 5-95	Convergence Point Array Room 3, Panel 7 at W660 S2350 – Room Center – All Chords.....	262
Figure 5-96	Convergence Point Array Room 3, Panel 7 at W660 S2425 – Roof to Floor.....	262
Figure 5-97	Convergence Point Array Room 4, Panel 7 at W790 S2275 – Roof to Floor.....	263
Figure 5-98	Convergence Point Array Room 4, Panel 7 at W790 S2350 – Room Center – All Chords.....	263
Figure 5-99	Convergence Point Array Room 4, Panel 7 at W790 S2425 – Roof to Floor.....	264
Figure 5-100	Convergence Point Array Room 5, Panel 7 at W920 S2275 – Roof to Floor.....	264
Figure 5-101	Convergence Point Array Room 5, Panel 7 at W920 S2350– Room Center – All Chords.....	265
Figure 5-102	Convergence Point Array Room 5, Panel 7 at W920 S2425 – Roof to Floor.....	265
Figure 5-103	Convergence Point Array Room 6, Panel 7 at W1050 S2275 – Roof to Floor.....	266
Figure 5-104	Convergence Point Array Room 6, Panel 7 at W1050 S2350 – Room Center – All Chords.....	266
Figure 5-105	Convergence Point Array Room 6, Panel 7 at W1050 S2425 – Roof to Floor.....	267
Figure 5-106	Convergence Point Array Room 7, Panel 7 at W1190 S2275 – Roof to Floor.....	267
Figure 5-107	Convergence Point Array Room 7, Panel 7 at W1190 S2350 – Room Center – All Chords.....	268

List of Figures

Figure	Title	Page No.
Waste Disposal Area Panel 7 (Continued)		
Figure 5-108	Convergence Point Array Room 7, Panel 7 at W1190 S2425 – Roof to Floor	268
Figure 5-109	Convergence Point Array S2520 W285 – Roof to Floor	269
Figure 5-110	Convergence Point Array S2520 W390 Intersection (Room 1, Panel 7) – Roof to Floor	269
Figure 5-111	Convergence Point Array S2520 W455 – Roof to Floor	270
Figure 5-112	Convergence Point Array S2520 W520 Intersection (Room 2, Panel 7) – Roof to Floor	270
Figure 5-113	Convergence Point Array S2520 W585 – Roof to Floor	271
Figure 5-114	Convergence Point Array S2520 W660 Intersection (Room 3, Panel 7) – Roof to Floor	271
Figure 5-115	Convergence Point Array S2520 W725 – Roof to Floor	272
Figure 5-116	Convergence Point Array S2520 W790 Intersection (Room 4, Panel 7) – Roof to Floor	272
Figure 5-117	Convergence Point Array S2520 W855 – Roof to Floor	273
Figure 5-118	Convergence Point Array S2520 W920 Intersection (Room 5, Panel 7) – Roof to Floor	273
Figure 5-119	Convergence Point Array S2520 W985 – Roof to Floor	274
Figure 5-120	Convergence Point Array S2520 W1050 Intersection (Room 6, Panel 7) – Roof to Floor	274
Figure 5-121	Convergence Point Array S2520 W1120 – Roof to Floor	275
Figure 5-122	Convergence Point Array S2520 W1190 Intersection (Room 7, Panel 7) – Roof to Floor	276
Salt Disposal Investigations		
Figure 6-1	Convergence Point Array E540 S17 – Roof to Floor	280
Figure 6-2	Convergence Point Array E540 S90 – Roof to Floor	280
Figure 6-3	Convergence Point Array E540 N55 – Roof to Floor	281
Figure 6-4	Convergence Point Array E540 N128 – Roof to Floor	281
Figure 6-5	Convergence Point Array E540 N200 – Roof to Floor	282
Figure 6-6	Convergence Point Array E540 N275 – Roof to Floor	282
Figure 6-7	Convergence Point Array E540 N350 – Roof to Floor	283
Figure 6-8	Convergence Point Array E540 N425 – Roof to Floor	283
Figure 6-9	Convergence Point Array E540 N500 – Roof to Floor	284
Figure 6-10	Convergence Point Array E540 N570 – Roof to Floor	284
Figure 6-11	Convergence Point Array E540 N640 – Roof to Floor	285
Figure 6-12	Convergence Point Array E540 N710 – Roof to Floor	285
Figure 6-13	Convergence Point Array E540 N860 – Roof to Floor	286
Figure 6-14	Convergence Point Array E690 S17 – Roof to Floor	286
Figure 6-15	Convergence Point Array E690 S90 – Roof to Floor	287
Figure 6-16	Convergence Point Array E690 N55 – Roof to Floor	287
Figure 6-17	Convergence Point Array E690 N128 – Roof to Floor	288
Figure 6-18	Convergence Point Array E690 N200 – Roof to Floor	288

List of Figures

Figure	Title	Page No.
Salt Disposal Investigations (Continued)		
Figure 6-19	Convergence Point Array E690 N275 – Roof to Floor	289
Figure 6-20	Convergence Point Array E690 N350 – Roof to Floor	289
Figure 6-21	Convergence Point Array E690 N425 – Roof to Floor	290
Figure 6-22	Convergence Point Array E690 N500 – Roof to Floor	290
Figure 6-23	Convergence Point Array E690 N640 – Roof to Floor	291
Figure 6-24	Convergence Point Array E690 N860 – Roof to Floor	291
Figure 6-25	Convergence Point Array N780 E220 – Roof to Floor	292
Figure 6-26	Convergence Point Array N780 E300 – Roof to Floor	292
Figure 6-27	Convergence Point Array N780 E420 – Roof to Floor	293
Figure 6-28	Convergence Point Array N780 E540 – Roof to Floor	293
Figure 6-29	Convergence Point Array N780 E615 – Roof to Floor	294
Figure 6-30	Convergence Point Array N780 E690 – Roof to Floor	294
Figure 6-31	Convergence Point Array N780 E768 – Roof to Floor	295
Figure 6-32	Convergence Point Array N780 E845 – Roof to Floor	295
Figure 6-33	Convergence Point Array N780 E922 – Roof to Floor	296
Figure 6-34	Convergence Point Array N780 E1000 – Roof to Floor	296
Figure 6-35	Convergence Point Array N780 E1050 – Roof to Floor	297
Figure 6-36	Convergence Point Array N780 E1100 – Roof to Floor	297
Figure 6-37	Convergence Point Array N780 E1150 – Roof to Floor	298
Figure 6-38	Convergence Point Array N780 E1200 – Roof to Floor	298
Figure 6-39	Convergence Point Array N780 E1250 – Roof to Floor	299
Figure 6-40	Convergence Point Array N940 E220 – Roof to Floor	299
Figure 6-41	Convergence Point Array N940 E300 – Roof to Floor	300
Figure 6-42	Convergence Point Array N940 E420 – Roof to Floor	300
Figure 6-43	Convergence Point Array N940 E540 – Roof to Floor	301
Figure 6-44	Convergence Point Array N940 E615 – Roof to Floor	301
Figure 6-45	Convergence Point Array N940 E690 – Roof to Floor	302
Figure 6-46	Convergence Point Array S90 E615 – Roof to Floor	302
Geosciences Program		
Figure 7-1	Panel 6 Room 1, S2761-S2861 Roof Fractures	341
Figure 7-2	Panel 6 Room 1, S2861-S2961 Roof Fractures	342
Figure 7-3	Panel 6 Room 1, S2961-S3061 Roof Fractures	343
Figure 7-4	Panel 6 South 2750, W370-W427 Roof Fractures	344
Figure 7-5	Panel 6 South 2750, W427-W527 Roof Fractures	345
Figure 7-6	Panel 6 South 3080, W370-W419 Roof Fractures	346
Figure 7-7	Panel 6 South 3080, W419-W519 Roof Fractures	347
Figure 7-8	Panel 7 Room 1, S2201-S2301 Roof Fractures	348
Figure 7-9	Panel 7 Room 1, S2301-S2401 Roof Fractures	349
Figure 7-10	Panel 7 Room 1, S2401-S2500 Roof Fractures	350
Figure 7-11	Panel 7 Room 2, S2201-S2301 Roof Fractures	351
Figure 7-12	Panel 7 Room 2, S2301-S2401 Roof Fractures	352
Figure 7-13	Panel 7 Room 2, S2401-S2500 Roof Fractures	353
Figure 7-14	Panel 7 Room 3, S2201-S2301 Roof Fractures	354

List of Figures

Figure	Title	Page No.
Geosciences Program (Continued)		
Figure 7-15	Panel 7 Room 3, S2301-S2401 Roof Fractures.....	355
Figure 7-16	Panel 7 Room 3, S2401-S2500 Roof Fractures.....	356
Figure 7-17	Panel 7 Room 4, S2201-S2301 Roof Fractures.....	357
Figure 7-18	Panel 7 Room 4, S2301-S2401 Roof Fractures.....	358
Figure 7-19	Panel 7 Room 4, S2401-S2500 Roof Fractures.....	359
Figure 7-20	Panel 7 Room 5, S2201-S2301 Roof Fractures.....	360
Figure 7-21	Panel 7 Room 5, S2301-S2401 Roof Fractures.....	361
Figure 7-22	Panel 7 Room 5, S2401-S2500 Roof Fractures.....	362
Figure 7-23	Panel 7 Room 6, S2201-S2301 Roof Fractures.....	363
Figure 7-24	Panel 7 Room 6, S2301-S2401 Roof Fractures.....	364
Figure 7-25	Panel 7 Room 6, S2401-S2505 Roof Fractures.....	365
Figure 7-26	Panel 7 Room 7, S2201-S2301 Roof Fractures.....	366
Figure 7-27	Panel 7 Room 7, S2301-S2401 Roof Fractures.....	367
Figure 7-28	Panel 7 Room 7, S2401-S2500 Roof Fractures.....	368
Figure 7-29	Panel 7 South 2180, W377-W427 Roof Fractures	369
Figure 7-30	Panel 7 South 2180, W427-W527 Roof Fractures	370
Figure 7-31	Panel 7 South 2180, W527-W627 Roof Fractures	371
Figure 7-32	Panel 7 South 2180, W627-W727 Roof Fractures	372
Figure 7-33	Panel 7 South 2180, W727-W827 Roof Fractures	373
Figure 7-34	Panel 7 South 2180, W827-W927 Roof Fractures	374
Figure 7-35	Panel 7 South 2180, W927-W1027 Roof Fractures	375
Figure 7-36	Panel 7 South 2180, W1027-W1127 Roof Fractures	376
Figure 7-37	Panel 7 South 2180, W1127-W1210 Roof Fractures	377
Figure 7-38	Panel 7 South 2520, W370-S419 Roof Fractures	378
Figure 7-39	Panel 7 South 2520, W419-W519 Roof Fractures	379
Figure 7-40	Panel 7 South 2520, W519-W619 Roof Fractures	380
Figure 7-41	Panel 7 South 2520, W619-W719 Roof Fractures	381
Figure 7-42	Panel 7 South 2520, W719-W819 Roof Fractures	382
Figure 7-43	Panel 7 South 2520, W819-W919 Roof Fractures	383
Figure 7-44	Panel 7 South 2520, W919-W1019 Roof Fractures	384
Figure 7-45	Panel 7 South 2520, W1019-W1119 Roof Fractures	385
Figure 7-46	Panel 7 South 2520, W1119-W1208 Roof Fractures	386

1.0 Introduction

This report is a compilation of geotechnical data presented as plots for each active instrument installed in the underground at the Waste Isolation Pilot Plant (WIPP) through June 30, 2013. A summary of the geotechnical analyses that were performed using the enclosed data is provided in Volume 1 of the Geotechnical Analysis Report (GAR).

1.1 Instrumentation

Geomechanical instrument data included in this report reflect the measurements of the geomechanical response of the underground and shafts. The instruments consist of convergence points, borehole extensometers, rockbolt load cells, pressure cells, strain gages, piezometers, and joint meters.

Closure measurements are taken at convergence points. Rock displacement is calculated by measuring the distance between two opposing points. Displacement is monitored over time and is plotted as closure versus time. Annual rates of closure are calculated for the convergence data and are compared with annual closure rates from previous reporting periods.

Borehole extensometers are used to determine the absolute movements of the ground around the openings. With these instruments, rods or wires are placed into a hole and anchored at various depths. The displacement at the extensometer head (located near the excavation face) is measured relative to each of the fixed anchors. These data are used in the extensometer *displacement* plots presented here. As part of the post-processing of acquired extensometer data a *relative displacement* value is calculated. The deepest anchor is assumed to be fixed in undisturbed ground and a displacement for the remaining anchors relative to the deepest anchor is calculated. Annual rates of collar displacement are calculated for each extensometer and are compared with the annual displacement rate reported during the previous reporting period.

Rockbolt load cells are used to determine the ground loading and the effectiveness of rockbolts. Plots consist of load versus time for each instrumented bolt.

Earth pressure cells and strain gages are used in and around the shaft liners to determine their loads. These are also depicted in time-based plots. Monitoring of these instruments indicates whether there is any stress buildup in the shaft lining systems.

Piezometers are used to measure the gauge pressure of groundwater. They have been installed in the shafts at varying elevations to monitor the hydraulic head acting on the shaft liners. Plots from piezometers are presented as pressure versus time.

Joint meters are installed perpendicular to a crack and monitor any changes in separation of the crack which may occur over time.

1.2 Data Plot Explanation

Data are presented in graphical form for ease in interpretation. Time-based plots are used in this report. Each plot generally consists of a legend in the upper right-hand corner that gives the array name and specific location of the instrument or point evaluated. The legend ties the graphical cross-sectional representation of the drift or shaft typically presented in the lower right-hand corner to the symbols on the curve in the graph. For extensometers, each anchor is designated with an alpha character "A" closest to the collar and "B," "C," "D," or "E" for the furthest point from the collar (the deepest anchor). For convergence points, the horizontal and vertical sections of the drift are referred to as chords. Breaks in the graph for convergence data and a numeric designator added to the legend typically indicate that the convergence point was lost due to normal mine maintenance activities and later reinstalled.

1.3 Report Organization

Chapter 1.0 provides an introduction to this Supporting Data volume of the GAR. Chapter 2.0 provides instrument data analysis for the Salt Handling Shaft, Waste Shaft, and Exhaust Shaft followed by data plots for the extensometers, piezometers, earth pressure cells, spot welded strain gages, and embedment strain gages installed in the shafts. Chapter 3.0 provides instrument data analysis for the Salt Handling Shaft Station and Waste Shaft Station, an instrument data summary only for the area immediately surrounding the Air Intake Shaft, and data plots for extensometers, convergence points, and rockbolt load cells for all three locations. Chapter 4.0 provides instrument data analysis for the access drifts followed by data plots for the extensometers, convergence points, joint meters and rock bolt load cells. Chapter 5.0 provides instrument data analysis for the Waste Disposal Area followed by data plots for the extensometers, rock bolt load cells and convergence points. Chapter 6.0 provides convergence point instrument data analysis for the Salt Disposal Investigations (SDI) area. Chapter 7.0 provides geologic data collected through the mapping of fractures, stratigraphic mapping and the observed displacements in vertical boreholes.

2.0 Instrumentation Summary for Shafts

Originally, the Salt, Waste and Exhaust Shafts were instrumented with geomechanical instrumentation. The instrument readings from the Waste and Exhaust Shafts are no longer available due to failed instruments, broken cabling and/or inoperative, obsolete data acquisition equipment. Table 2-1 presents data and analysis of the Salt Shaft. Plots of the instrument data are presented as Figures 2-1 through 2-12.

**Table 2-1
Salt Handling Shaft Data Analysis**

Piezometers								
Field Tag	Level feet	Figure Number	Date of 2012-2013 Max. Reading	2012-2013 Maximum Pressure Readings (psi)	Date of 2011-2012 Max. Reading	2011-2012 Maximum Pressure Readings (psi)	Change in Maximum Pressure From Previous Year (psi)	Comments
37X-PE-00201	580	2-1	03/08/13	88	03/05/12	81	7	
37X-PE-00202	580	2-1	05/09/13	96	03/05/12	87	9	
37X-PE-00203	620	2-2	03/08/13	192	03/05/12	151	41	
37X-PE-00204	620	2-2	07/30/12	155	03/05/12	142	13	
37X-PE-00205	691	2-3	06/06/13	199	03/05/12	135	64	
37X-PE-00206	691	2-3	06/06/13	196	03/05/12	132	64	
37X-PE-00209	802	2-4	08/08/12	62	10/17/11	62	0	
37X-PE-00210	802	2-4	09/27/12	62	10/17/11	63	-1	
37X-PE-00211	850	2-5	08/08/12	96	10/17/11	45	51	
37X-PE-00212	850	2-5	06/06/13	131	03/05/12	57	74	

Earth Pressure Cells								
Field Tag	Level feet	Figure Number	Date of 2012-2013 Max. Reading	2012-2013 Maximum Pressure Readings (psi)	Date of 2011-2012 Max. Reading	2011-2012 Maximum Pressure Readings (psi)	Change in Maximum Pressure From Previous Year (psi)	Comments
37X-WE-00201	860	2-6	08/08/12	-6	10/17/11	-9	3	
37X-WE-00202	860	2-6	08/08/12	-26	10/17/11	-27	1	
37X-WE-00203	860	2-6	05/09/13	6	03/05/12	4	2	

Table 2-1
Salt Handling Shaft Data Analysis (Continued)

Spot-Welded Strain Gages								
Field Tag	Level Feet	Figure Number	Date of 2012-2013 Max. Reading	2012-2013 Maximum Strain Readings ($\mu\epsilon$)	Date of 2011-2012 Max. Reading	2011-2012 Maximum Strain Readings ($\mu\epsilon$)	Change in Maximum Strain From Previous Year ($\mu\epsilon$)	Comments
37X-ZE-00206	856.3	2-7	08/08/12	686	10/17/11	590	96	
37X-ZE-00220	862.4	2-8	09/19/12	956	10/17/11	942	14	
37X-ZE-00223	862.4	2-8	11/12/12	714	10/17/11	687	27	

Embedment Strain Gages								
Field Tag	Level feet	Figure Number	Date of 2012-2013 Max. Reading	2012-2013 Maximum Strain Readings ($\mu\epsilon$)	Date of 2011-2012 Max. Reading	2011-2012 Maximum Strain Readings ($\mu\epsilon$)	Change in Maximum Strain From Previous Year ($\mu\epsilon$)	Comments
37X-ZE-00209	856.3	2-9	03/08/13	-536	01/04/12	-543	7	
37X-ZE-00210	856.3	2-9	08/08/12	1030	10/17/11	970	60	
37X-ZE-00211	856.3	2-9	08/08/12	364	10/17/11	336	28	
37X-ZE-00212	856.3	2-9	01/02/13	-858	12/05/11	-914	56	
37X-ZE-00213	856.3	2-9	08/08/12	402	10/17/11	369	33	
37X-ZE-00214	856.3	2-9	08/08/12	166	12/05/11	-85	251	
37X-ZE-00215	856.3	2-9	08/08/12	155	10/17/11	123	32	
37X-ZE-00216	856.3	2-9	08/08/12	694	10/17/11	618	76	
37X-ZE-00235	856.3	2-10	08/08/12	314	10/17/11	280	34	
37X-ZE-00236	856.3	2-10	02/04/13	-403	01/04/12	-414	11	
37X-ZE-00237	856.3	2-10	08/08/12	155	12/05/11	-156	311	
37X-ZE-00238	856.3	2-10	08/08/12	150	10/17/11	81	69	
37X-ZE-00225	862.4	2-11	08/08/12	575	10/17/11	522	53	
37X-ZE-00239	862.4	2-12	08/08/12	429	10/17/11	397	32	

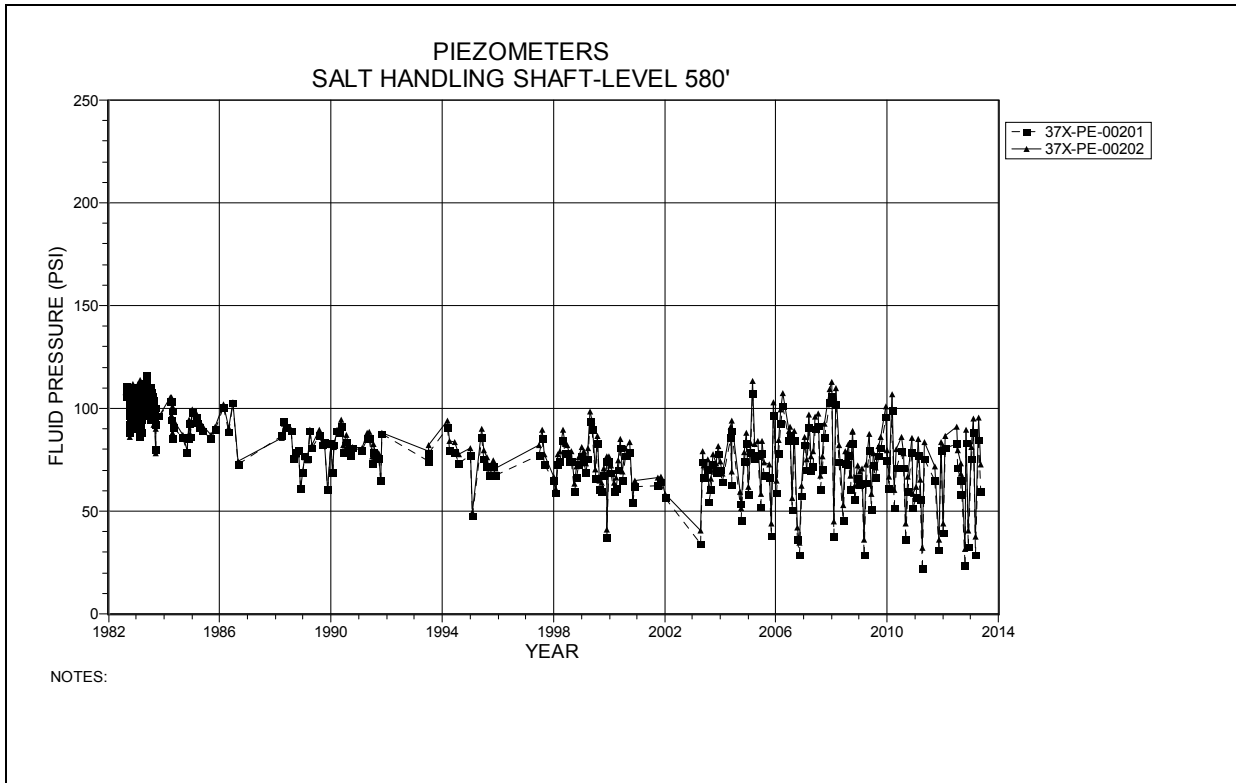

Figure 2-1 Piezometers Salt Handling Shaft – Level 580 at the Forty-niner Member

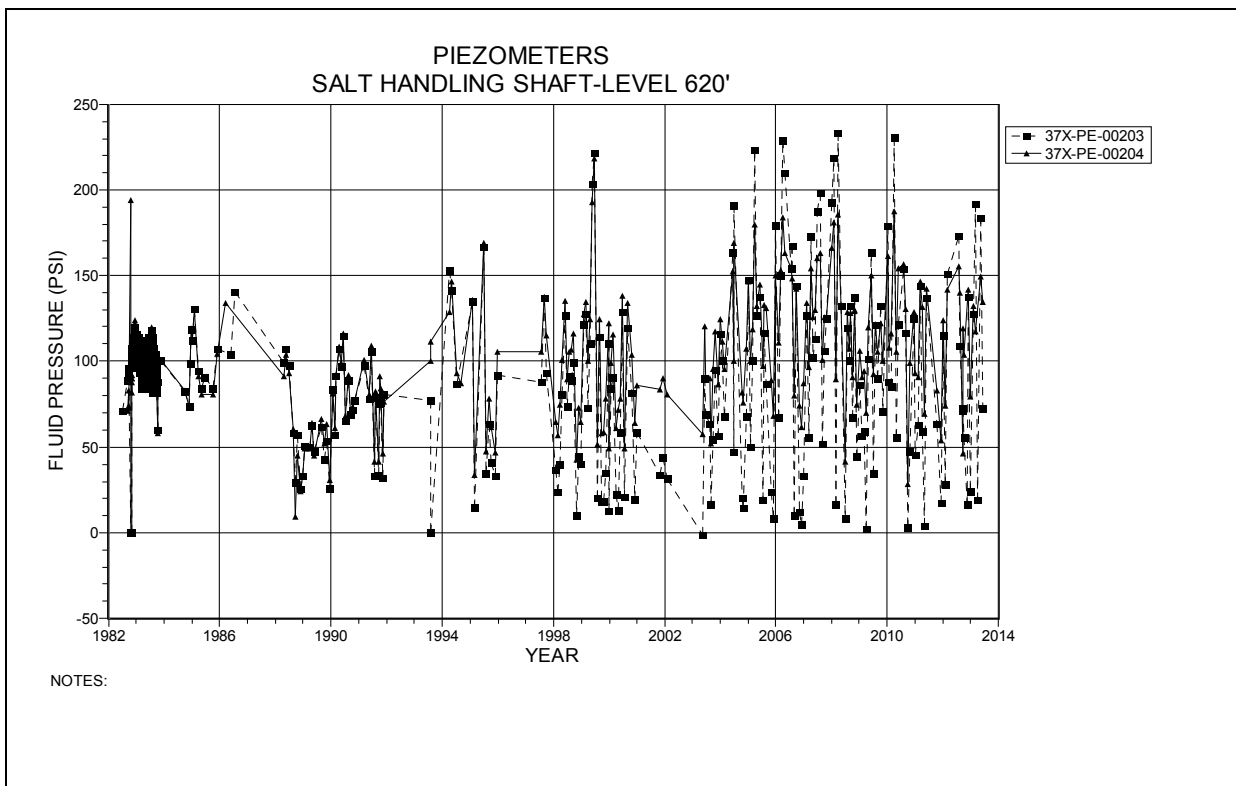

Figure 2-2 Piezometers Salt Handling Shaft – Level 620 at the Magenta Dolomite Member

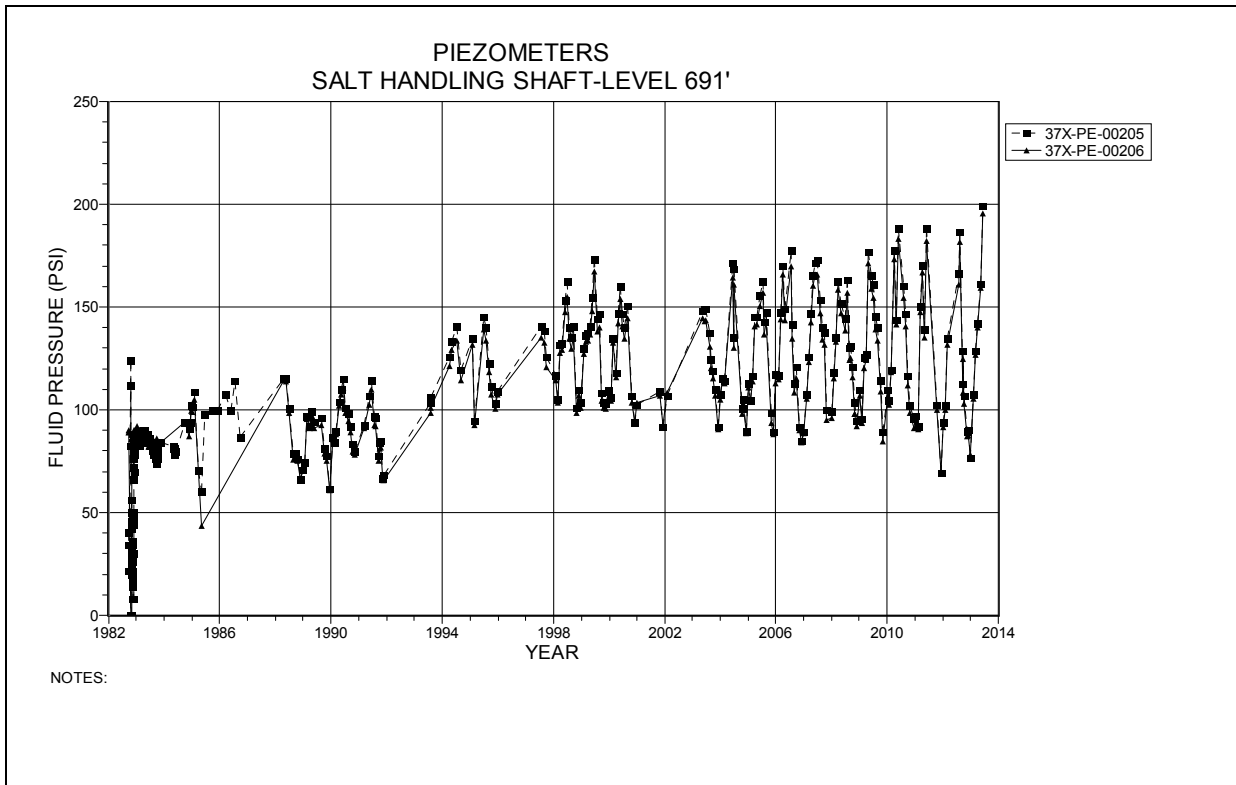

Figure 2-3 Piezometers Salt Handling Shaft
– Level 691 at the Tamarisk Member

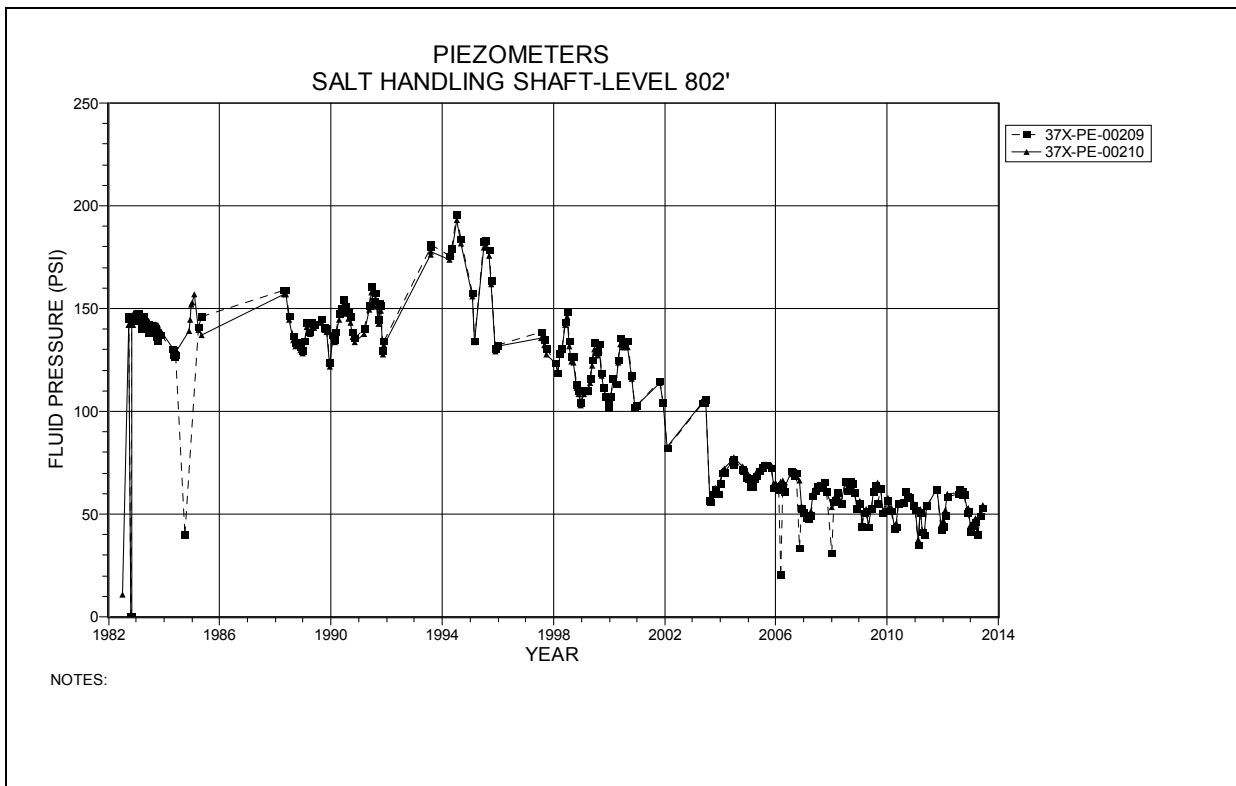

Figure 2-4 Piezometers Salt Handling Shaft
– Level 802 at the Los Medaños Member

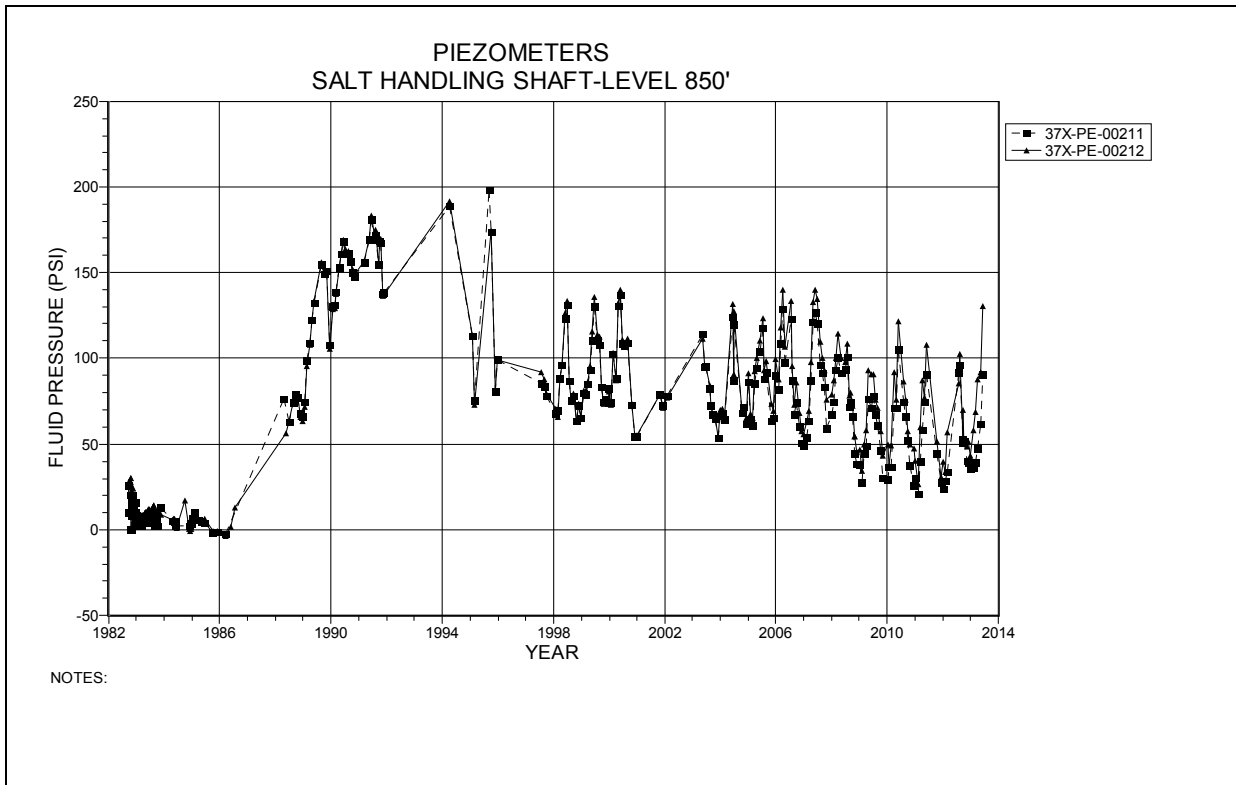

Figure 2-5 Piezometers Salt Handling Shaft
 – Level 850 at the Rustler-Salado Contact

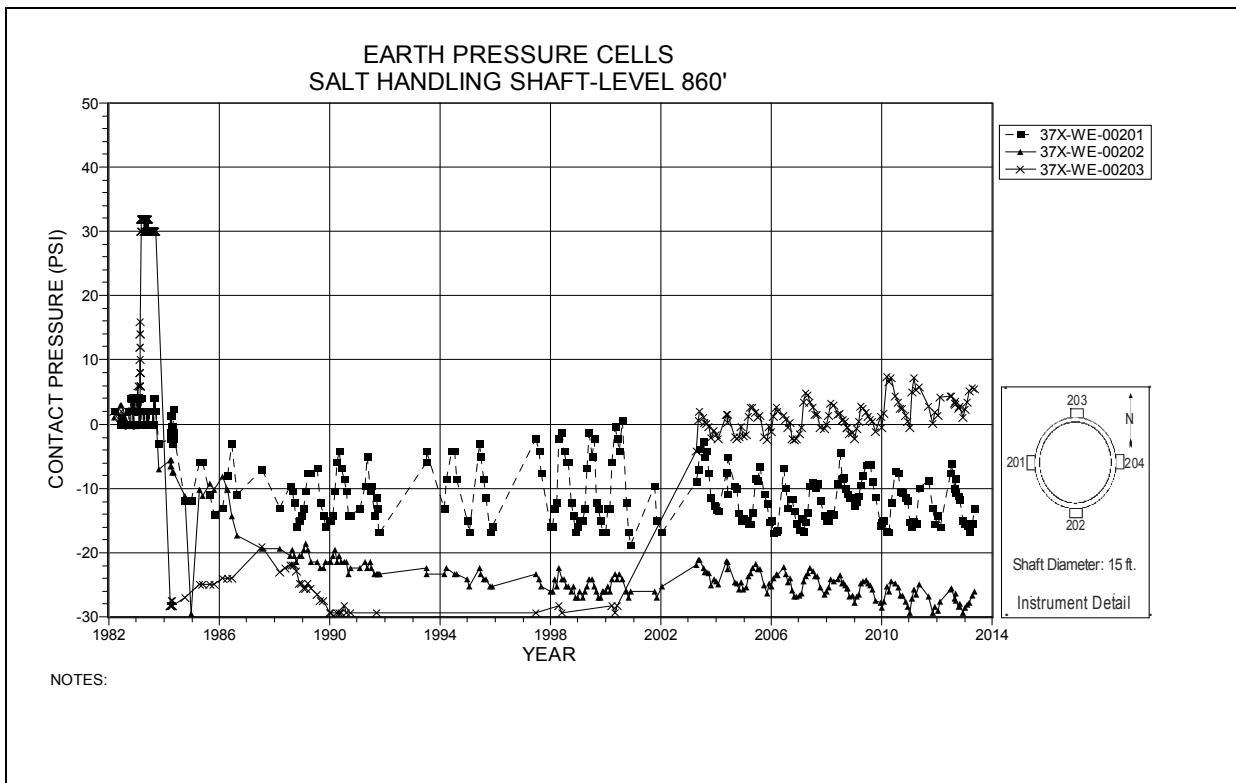

Figure 2-6 Earth Pressure Cells Behind Shaft Key
 Salt Handling Shaft Key – Level 860

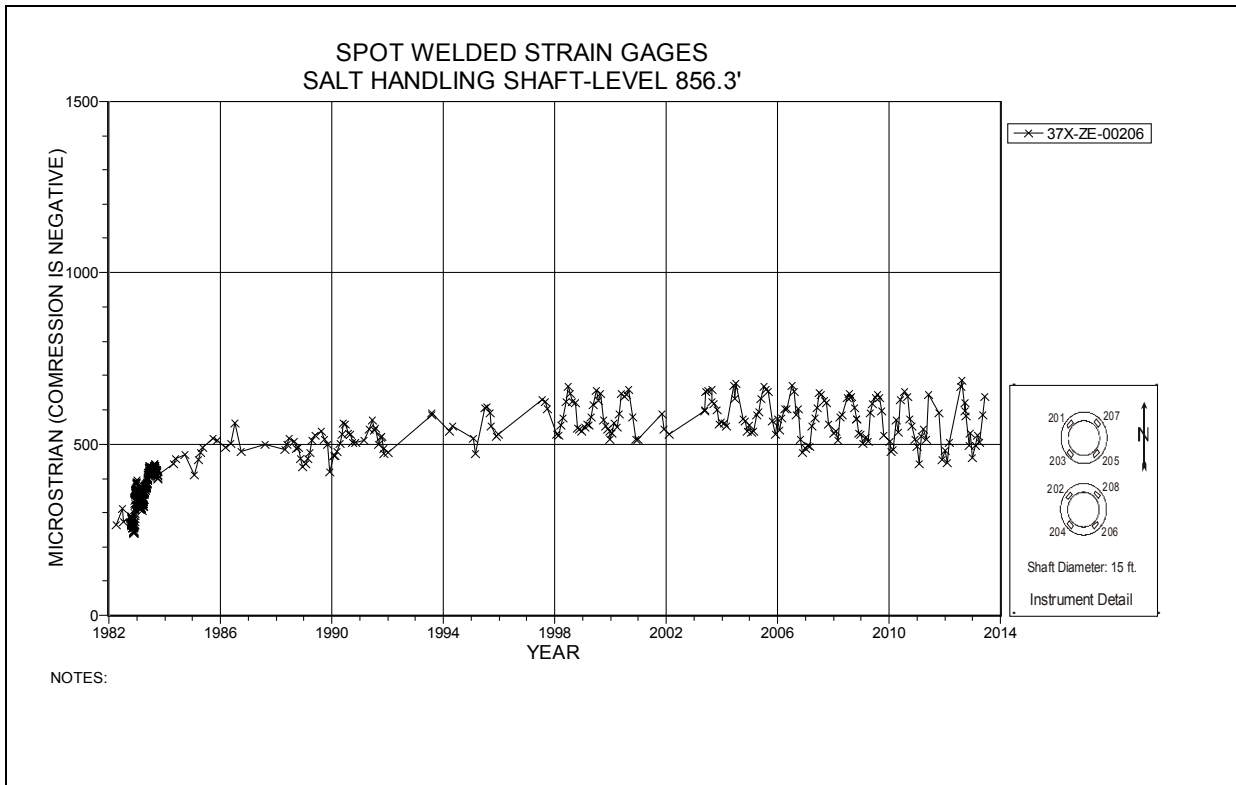

Figure 2-7 Spot-Welded Strain Gage
Salt Handling Shaft Key – Level 856.3

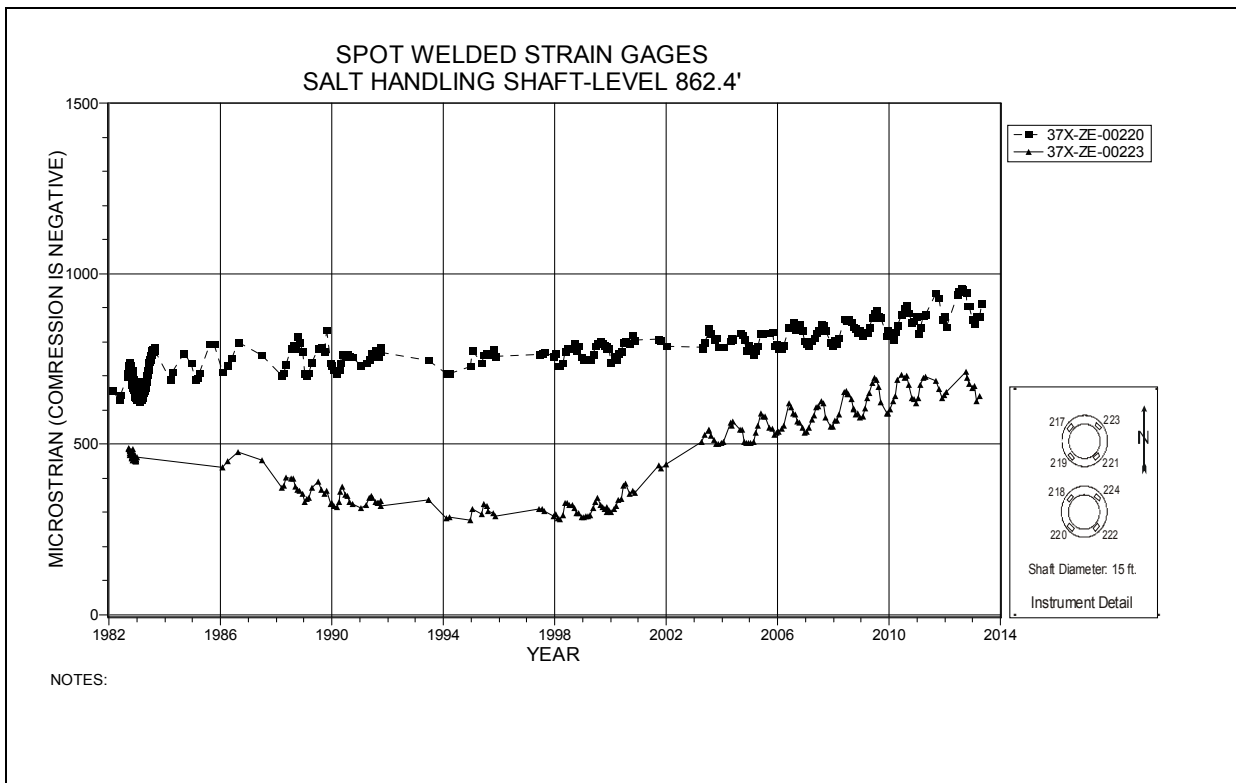

Figure 2-8 Spot-Welded Strain Gages
Salt Handling Shaft Key – Level 862.4

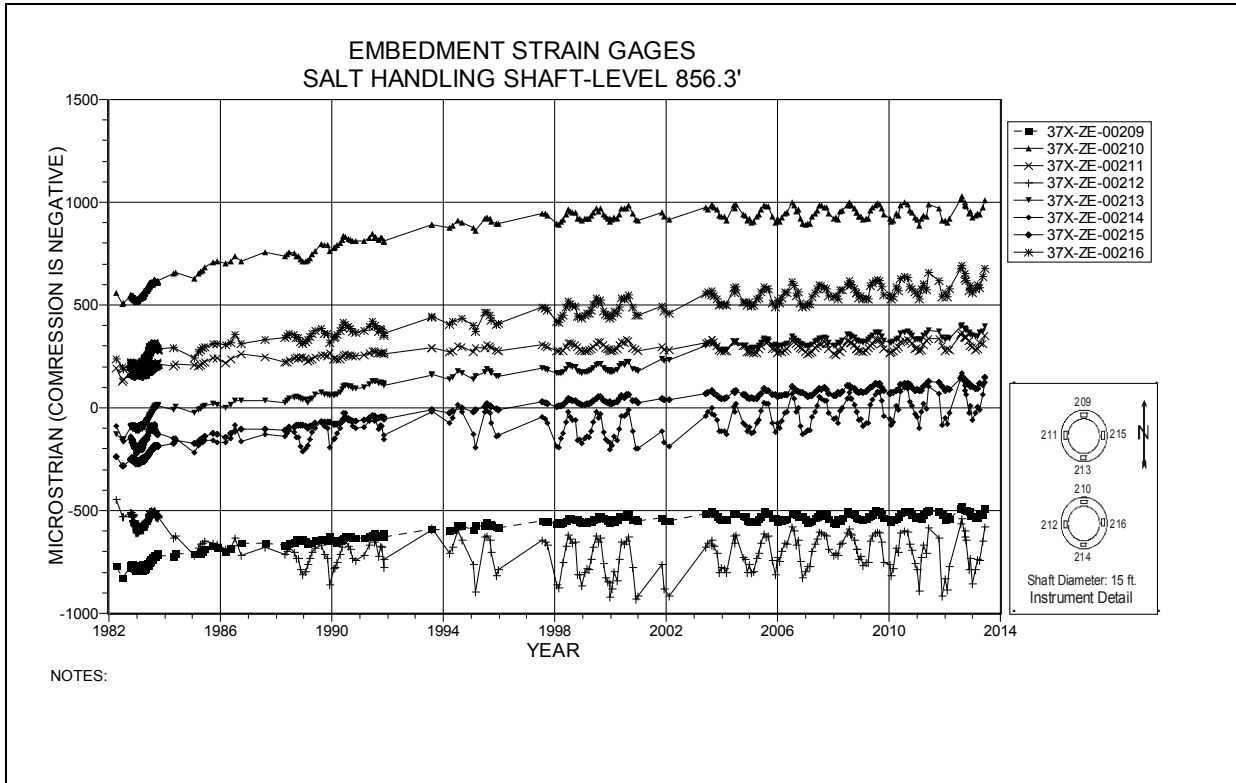

Figure 2-9 Embedment Strain Gages
Salt Handling Shaft Key – Level 856.3

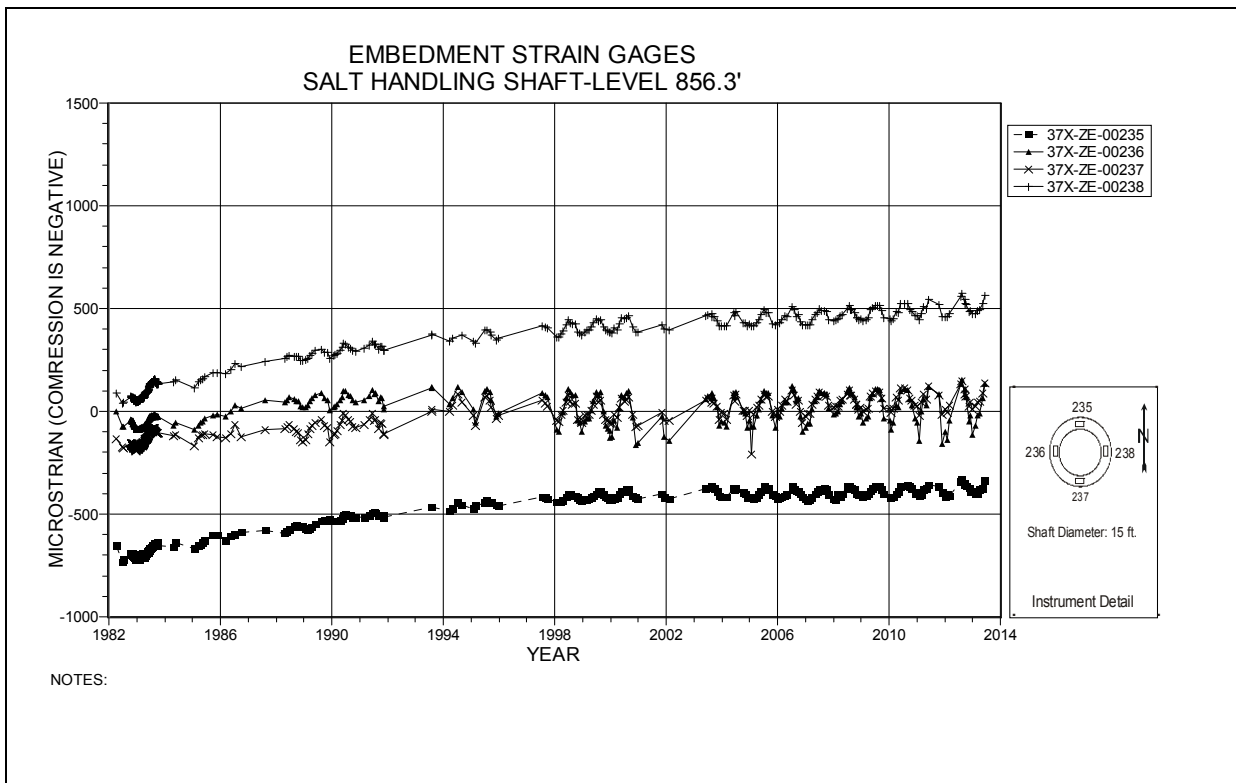

Figure 2-10 Embedment Strain Gages
Salt Handling Shaft Key Level 856.3

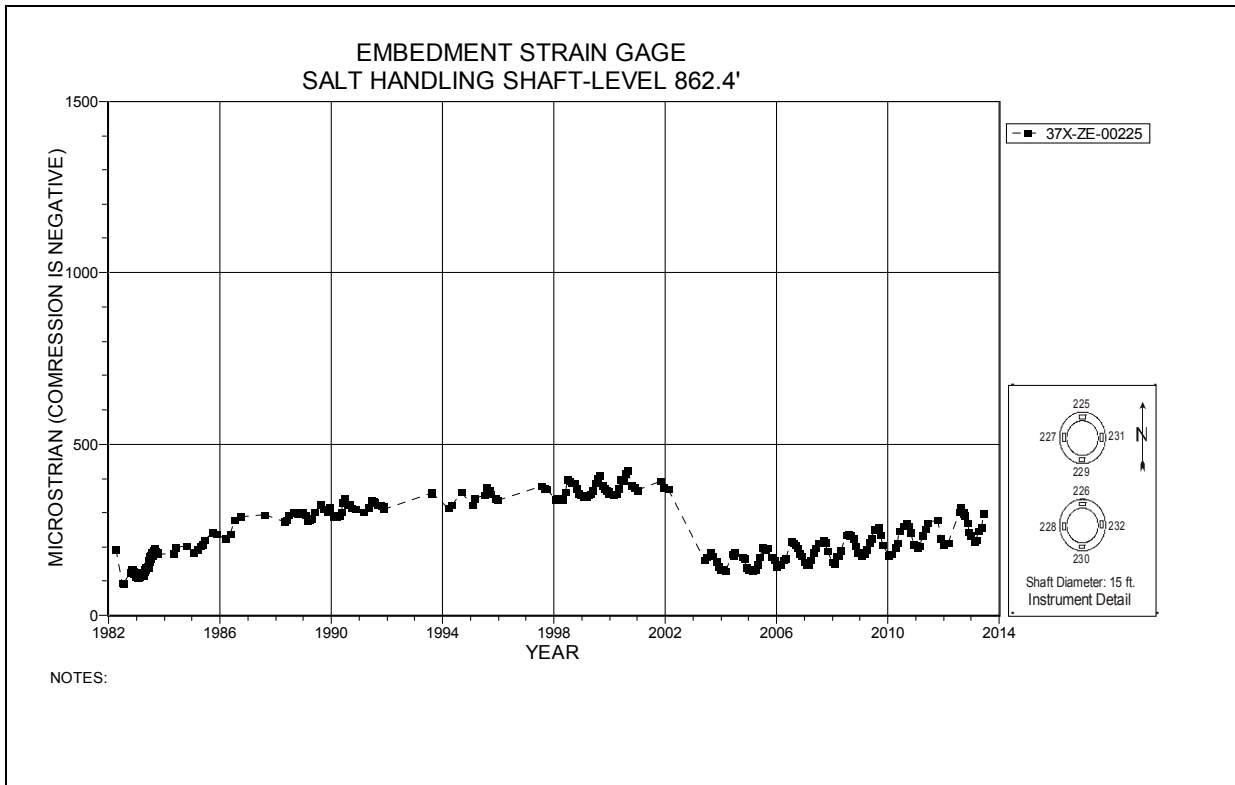

Figure 2-11 Embedment Strain Gage
Salt Handling Shaft Key Level 862.4

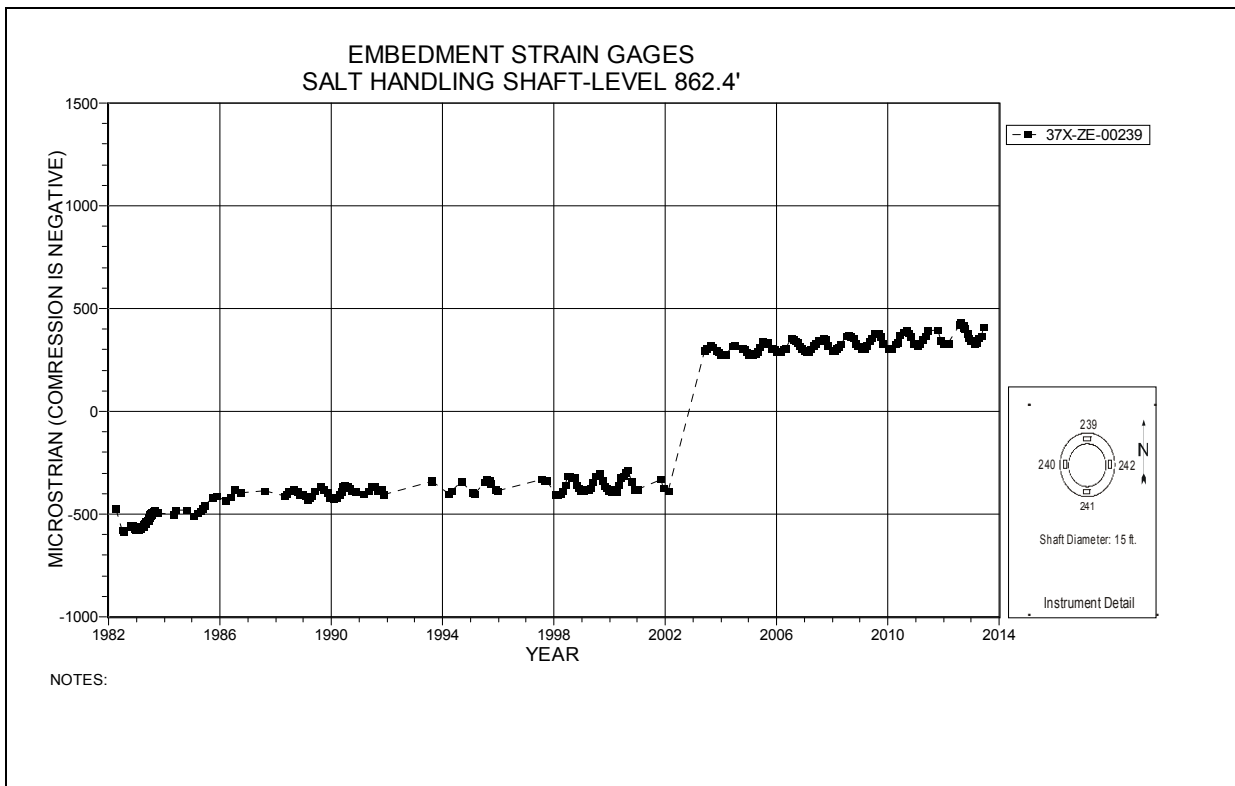

Figure 2-12 Embedment Strain Gage
Salt Handling Shaft Key – Level 862.4

This page was intentionally left blank.

3.0 Instrumentation Summary for Shaft Stations

Instrumentation data analysis for the Salt Handling Shaft Station, Waste Shaft Station, and the area around the Air Intake Shaft follow. Table 3-1 presents data analyses for each of the Salt Handling Shaft Station instruments. Figures 3-1 through 3-6 present plots of the instrumentation data for the Salt Handling Shaft Station.

Table 3-2 presents data and analysis for the Waste Shaft Station. Plots from the instrumentation in the Waste Shaft Station are presented as Figures 3-7 through 3-10.

Table 3-3 and Figures 3-11 through 3-16 present the data from rock bolt load cells and borehole extensometers located in the immediate area around the Air Intake Shaft.

**Table 3-1
Salt Handling Shaft Station Data Analysis**

Convergence Points									
Field Tag	Location	Figure Number	Last Reading 2012-2013		Cumulative Displacement (inches)	Closure Rate 2012 to 2013 (in/year)	Closure Rate 2011 to 2012 (in/year)	Rate Change Percent	Comments
			Date	Inches					
E0-S18-8 A-E	E0 Drift-S18	3-1	06/05/13	2.506	23.658	1.7	2.5	-32%	
E0-S18-6 B-D	E0 Drift-S18	3-2	06/05/13	2.767	25.866	1.9	2.6	-27%	
E0-S18-5 H-F	E0 Drift-S18	3-2	06/05/13	1.576	16.037	1.1	1.5	-27%	
E0-S30-6 A-C	E0 Drift-S30	3-3	06/05/13	2.468	24.499	1.7	2.3	-26%	
E0-S65-5 A-C	E0 Drift-S65	3-4	06/05/13	1.708	17.068	1.2	1.5	-20%	

Extensometers								
Field Tag	Location	Figure Number	Date of Last Reading	Collar Displacement Relative to Deepest Anchor (inches)	Displacement Rate 2012 to 2013 (in/year)	Displacement Rate 2011 to 2012 (in/year)	Rate Change Percent	Comments
51X-GE-01026-2	E0-S30 Roof	3-5	06/05/13	1.213	0.4	0.4	0%	
51X-GE-01027-2	E0-S60 Roof	3-6	06/05/13	0.816	0.3	0.2	50%	

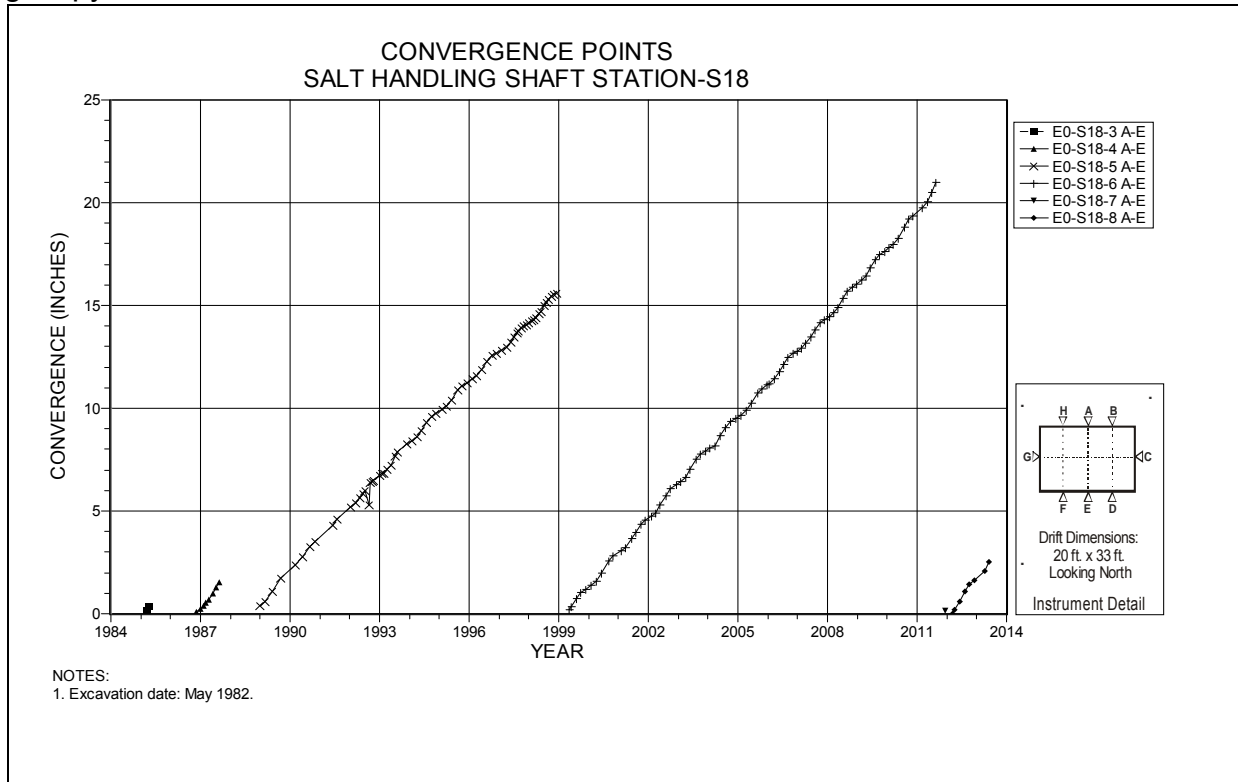

Figure 3-1 Convergence Point Array
Salt Handling Shaft Station at S18 – Centerline – Roof to Floor

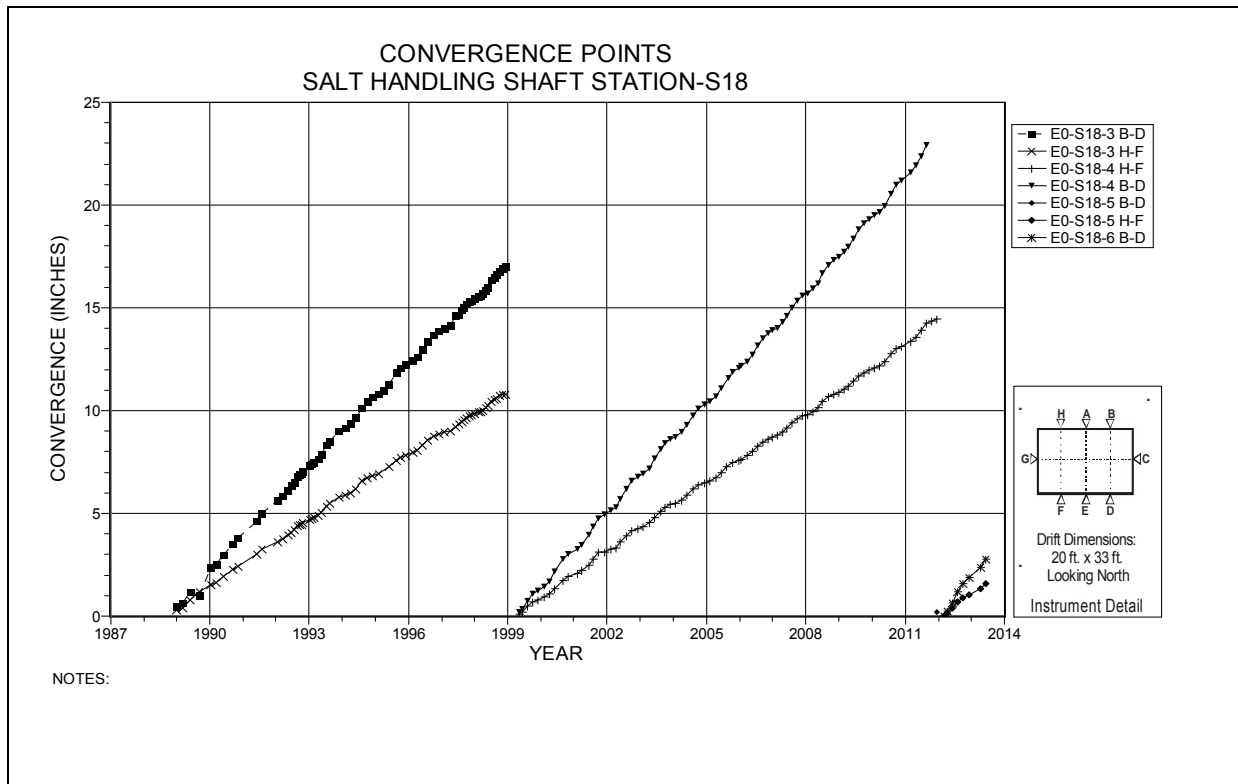

Figure 3-2 Convergence Point Array
Salt Handling Shaft Station at S18 – Quarter Points – Roof to Floor

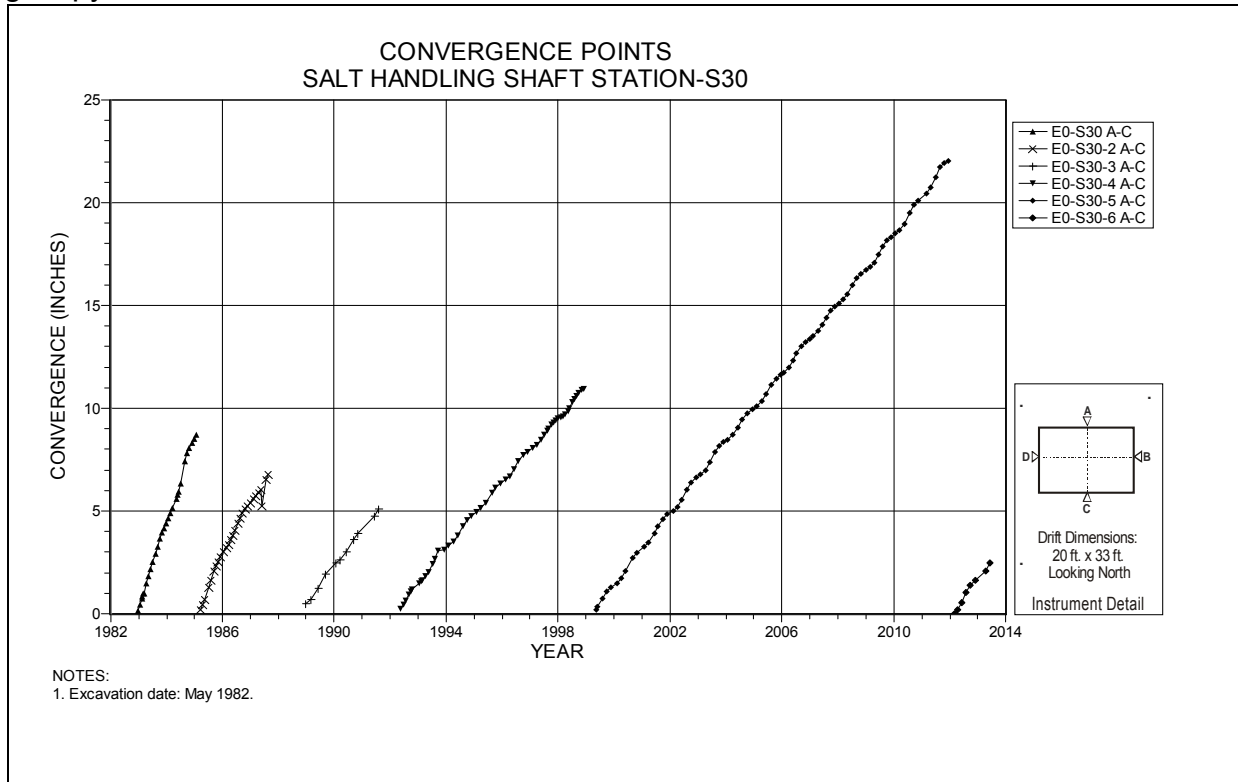

Figure 3-3 Convergence Point Array
Salt Handling Shaft Station at S30 – Roof to Floor

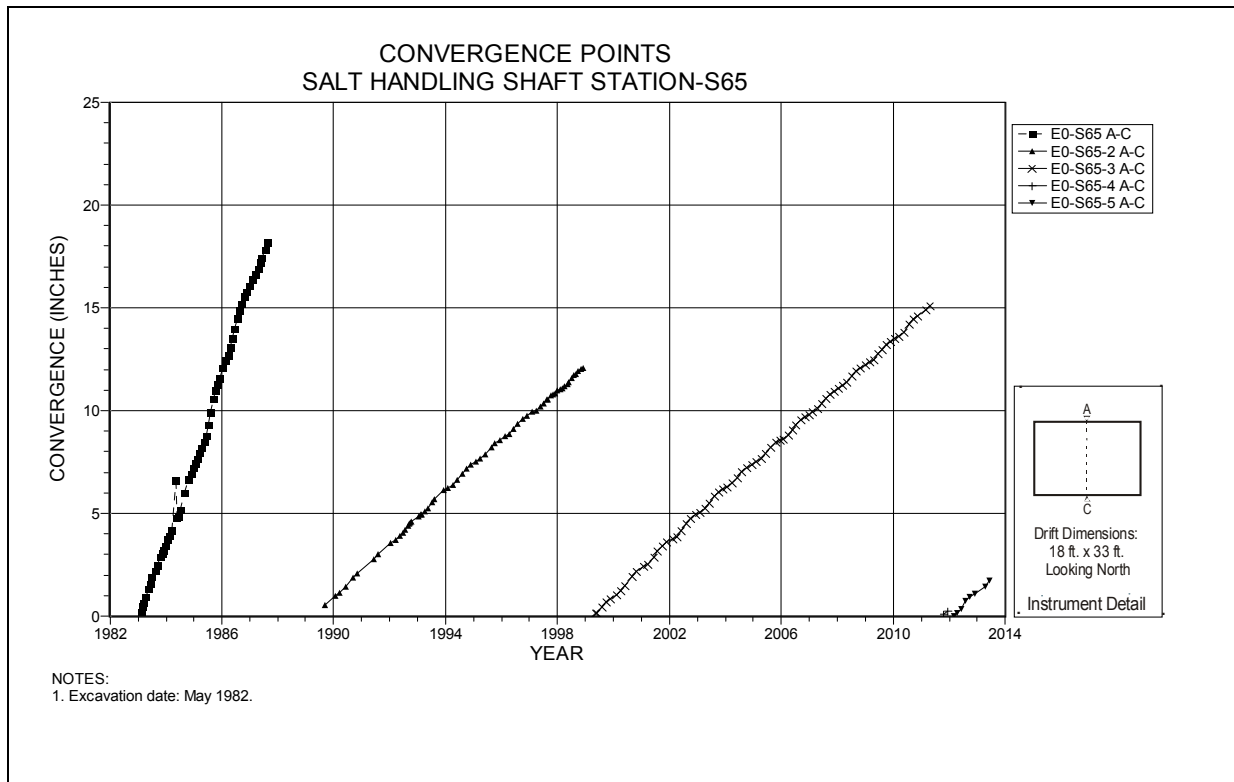

Figure 3-4 Convergence Point Array
Salt Handling Shaft Station at S65 – Roof to Floor

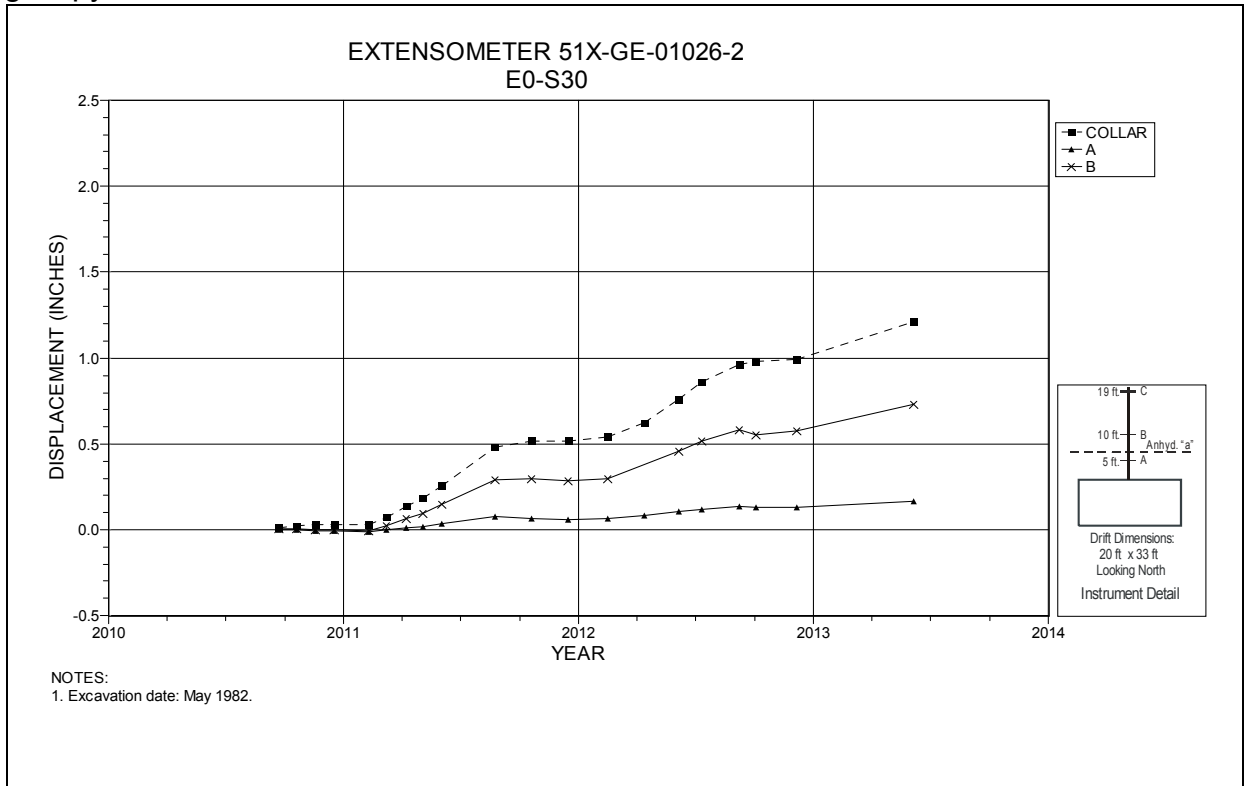

Figure 3-5 Extensometer 51X-GE-001026-2
Salt Handling Shaft Station at S30 – Roof

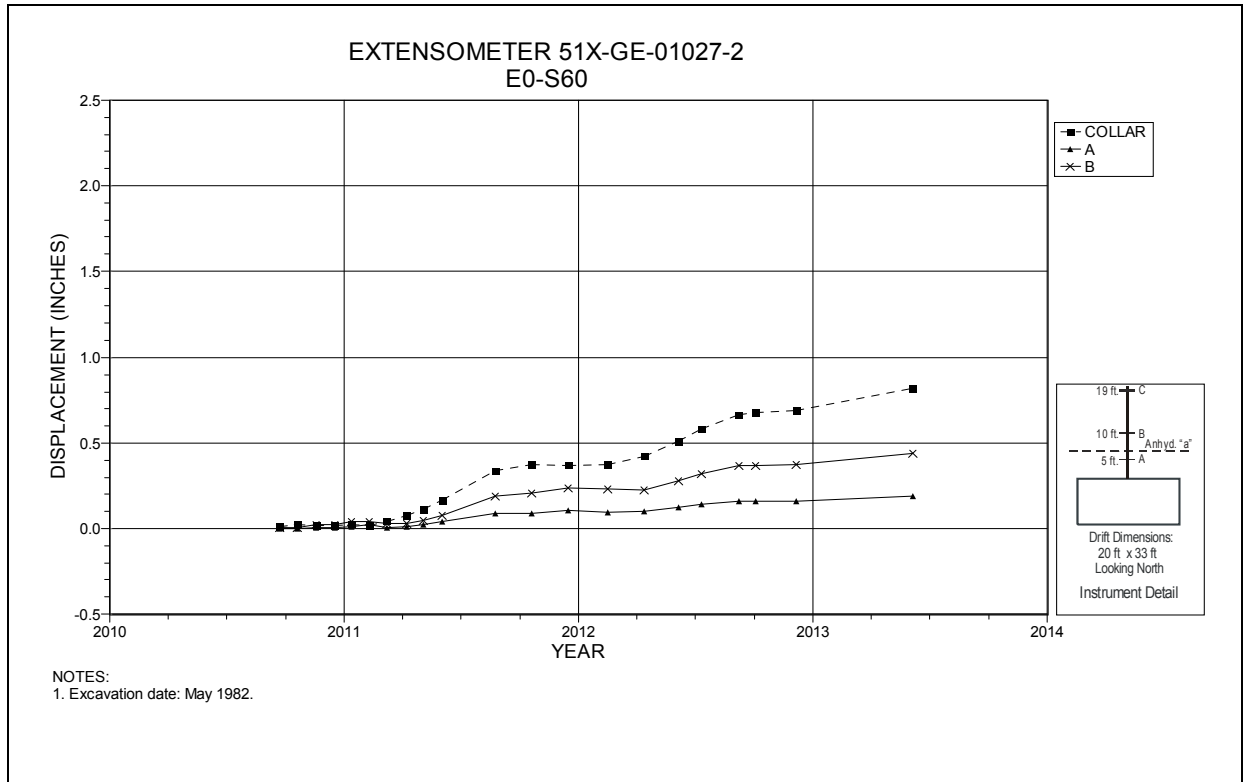

Figure 3-6 Extensometer 51X-GE-001027-2
Salt Handling Shaft Station at S60 – Roof

Table 3-2
Waste Shaft Station Data Analysis

Extensometers										
Fieldtag	Location	Figure Number	Date of Last Reading	Collar Displacement Relative to Deepest Anchor (inches)	Displacement Rate 2012 to 2013 (in/year)	Displacement Rate 2011 to 2012 (in/year)	Rate Change Percent	Comments		
51X-GE-00268	Waste Shaft Station - W30	3-7	06/05/13	11.079	0.0	0.1	-100%			
51X-GE-00404-2	Waste Shaft Station - E35	3-8	06/28/13	0.934	0.3	0.3	0%			
Convergence Points										
Field Tag	Location	Figure Number	Last Reading 2012-2013		Cumulative Displacement (inches)	Closure Rate 2012 to 2013 (in/year)	Closure Rate 2011 to 2012 (in/year)	Rate Change Percent	Comments	
			Date	Inches						
S400-E32 B-D	Waste Shaft Station - E32	3-9	06/25/13	5.690	5.690	1.4	1.2	17%		
S400-E85 B-D	Waste Shaft Station - E85	3-10	06/25/13	5.780	5.780	1.4	1.2	17%		

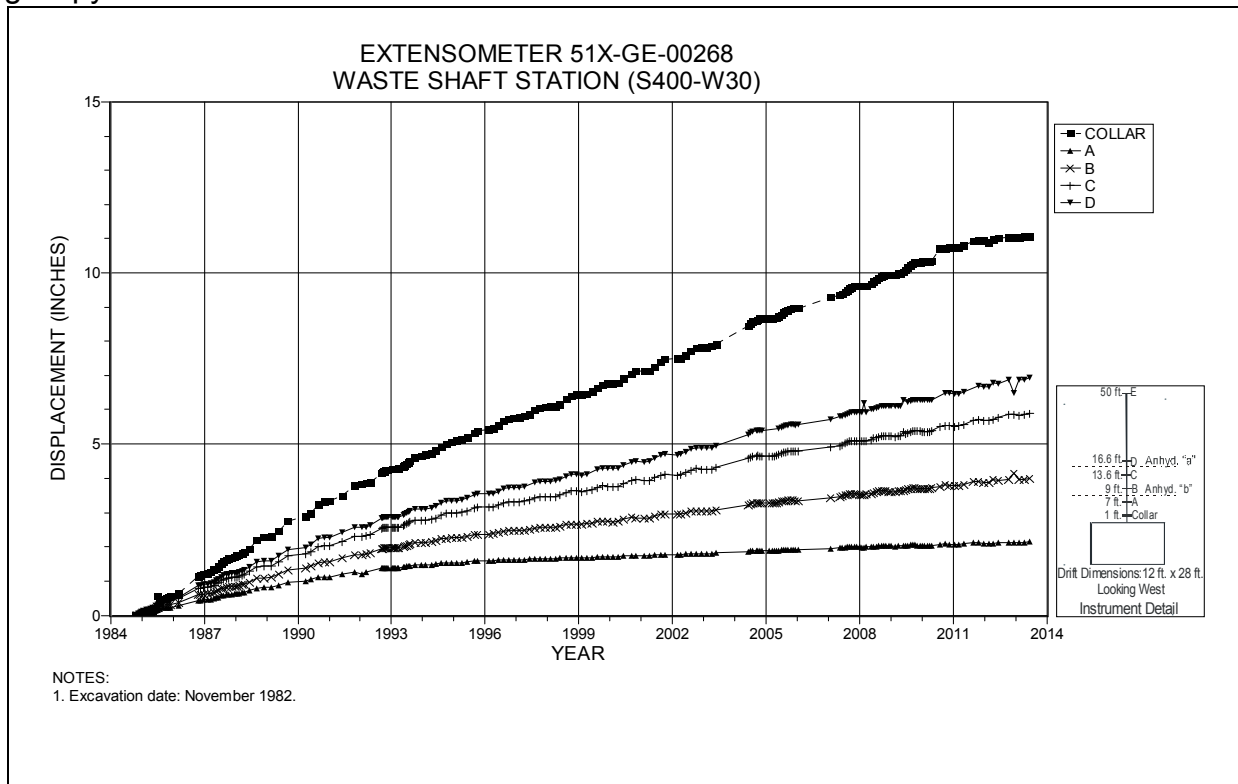

Figure 3-7 Extensometer 51X-GE-00268
Waste Shaft Station at S400 W30 – Roof

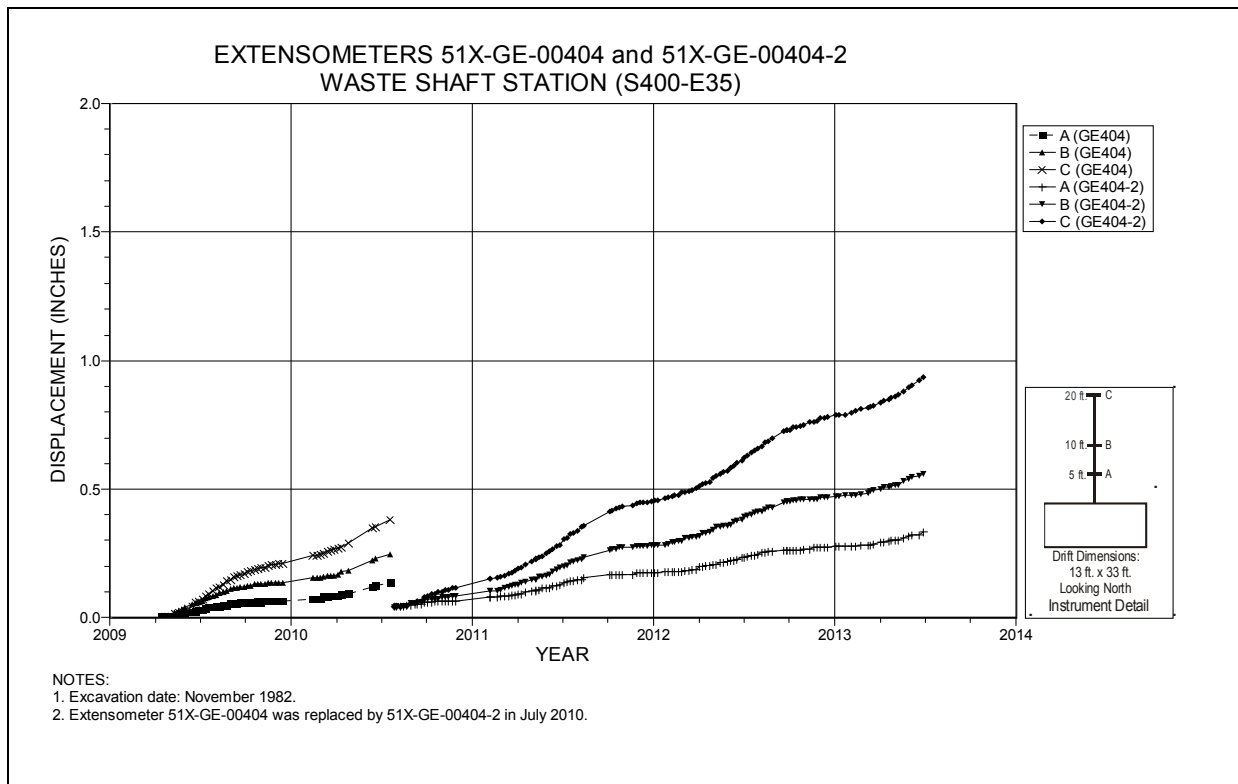

Figure 3-8 Extensometers 51X-GE-00404 and 51X-GE-00404-2
Waste Shaft Station at S400 E35 – Roof

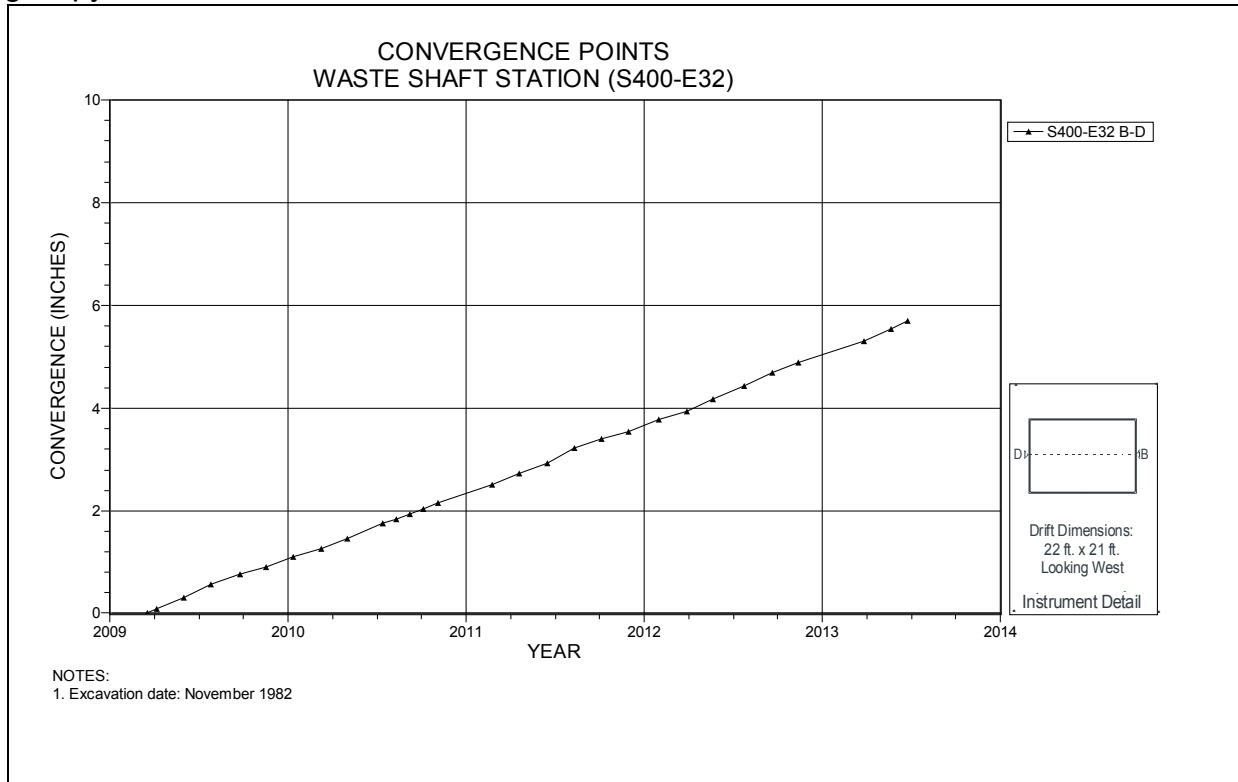

Figure 3-9 Convergence Point Array
Waste Shaft Station at S400 E32 – Rib to Rib

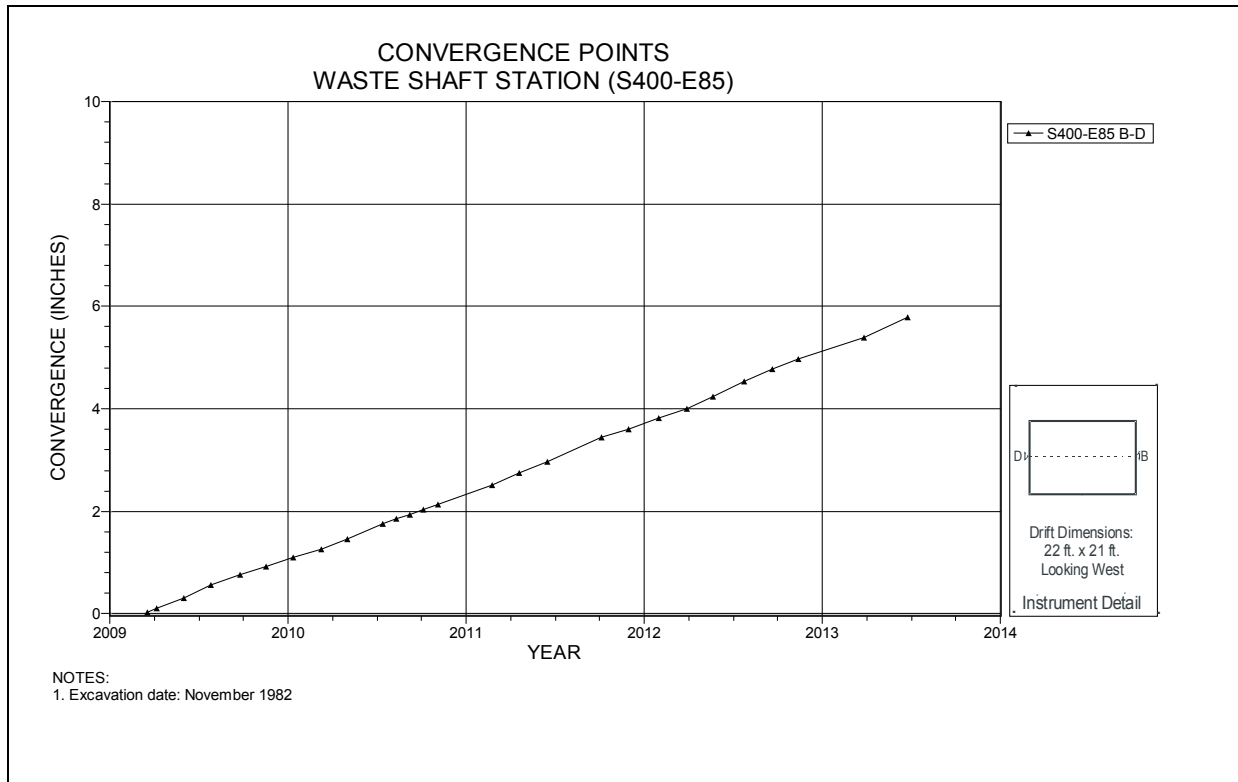

Figure 3-10 Convergence Point Array
Waste Shaft Station at S400 E85 – Rib to Rib

Table 3-3
Air Intake Shaft Station Data Analysis

Extensometers								
Field Tag	Location	Figure Number	Date of Last Reading	Collar Displacement Relative to Deepest Anchor (Inches)	Displacement Rate 2012 to 2013 in/year	Displacement Rate 2011 to 2012 in/year	Rate Change Percent	Comments
41X-GE-00122	W620-S65	3-11	05/09/13	4.620	0.1	0.3	-67%	Anchor "D" has reached its maximum range. Anchor "C" readings were used in the calculations.
41X-GE-00123	W620-N93	3-12	06/28/13	4.734	0.3	0.2	50%	The Collar and "C" anchors have reached their maximum range. Anchor "B" readings were used.
Rockbolt Load Cells								
Field Tag	Location	Figure Number	Date of Initial Reading	Date of Last Reading	Load (kips)	Comments		
51X-WG-00236	AIS Station Brow - South	3-13	01/19/93	06/28/13	66.9			
51X-WG-00237	AIS Station Brow - South	3-13	01/19/93	06/28/13	1.6	The rock bolt has failed.		
51X-WG-00238	AIS Station Brow - South	3-13	01/19/93	06/28/13	1.9			
51X-WG-00239	AIS Station Brow - South	3-13	01/19/93	06/28/13	38.4			
51X-WG-00240	AIS Station Brow - South	3-13	01/19/93	06/28/13	3.0			
51X-WG-00241	AIS Station Brow - South	3-14	01/19/93	06/28/13	69.7			
51X-WG-00242	AIS Station Brow - South	3-14	01/19/93	06/28/13	30.2			
51X-WG-00243	AIS Station Brow - South	3-14	01/19/93	06/28/13	25.2			
51X-WG-00244	AIS Station Brow - South	3-14	12/24/94	06/28/13	25.8			
51X-WG-00245	AIS Station Brow - South	3-14	01/19/93	06/28/13	0.7	The rock bolt has failed.		
51X-WG-00246	AIS Station Brow - North	3-15	01/19/93	06/28/13	27.4			
51X-WG-00247	AIS Station Brow - North	3-15	01/19/93	06/28/13	2.0	The rock bolt has failed.		
51X-WG-00248	AIS Station Brow - North	3-15	01/19/93	06/28/13	11.3			
51X-WG-00249	AIS Station Brow - North	3-15	01/19/93	06/28/13	0.3	The rock bolt has failed.		
51X-WG-00250	AIS Station Brow - North	3-15	12/24/94	06/28/13	16.6			
51X-WG-00251	AIS Station Brow - North	3-16	01/19/93	06/28/13	32.3			
51X-WG-00252	AIS Station Brow - North	3-16	01/19/93	06/28/13	99.4	The load cell or the instrument cable to the cell has been damaged.		
51X-WG-00253	AIS Station Brow - North	3-16	01/19/93	06/28/13	64.0			
51X-WG-00254	AIS Station Brow - North	3-16	01/19/93	06/28/13	11.9			
51X-WG-00255	AIS Station Brow - North	3-16	01/19/93	06/28/13	24.9			

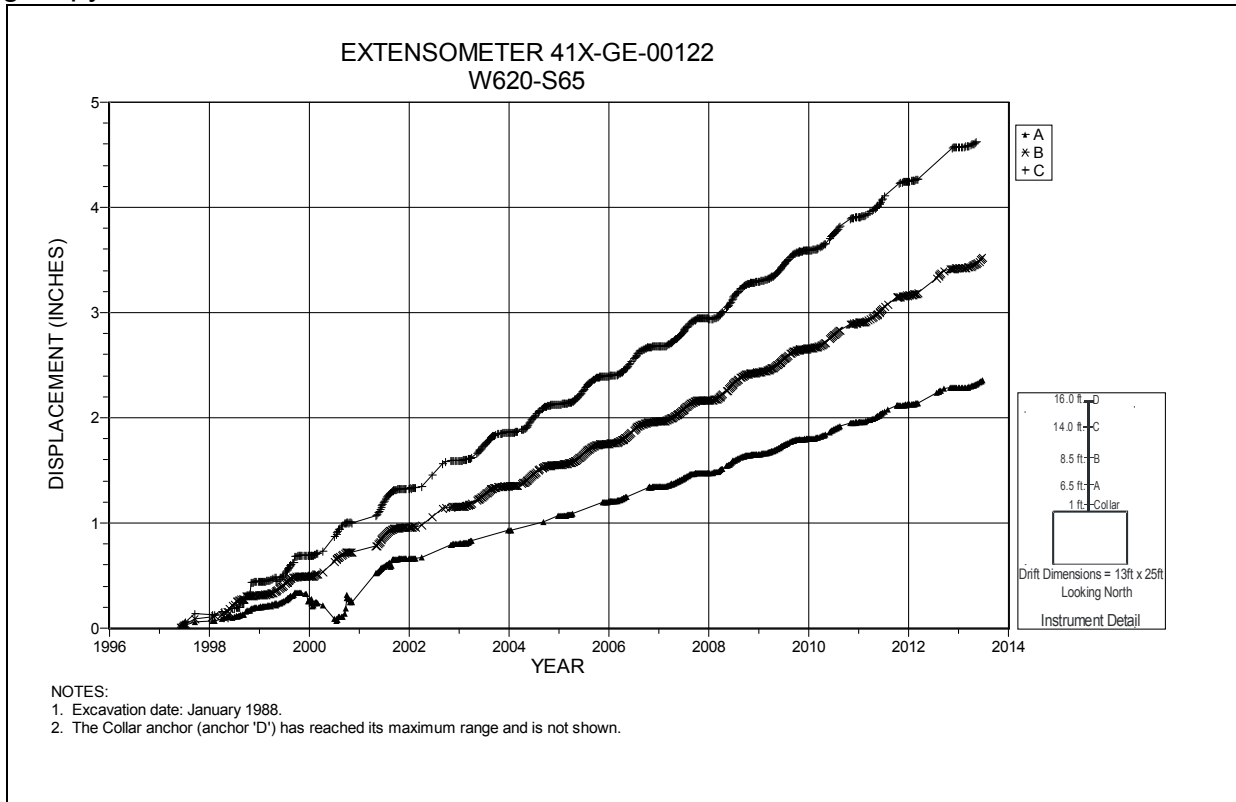

Figure 3-11 Extensometer 41X-GE-00122
Air Intake Shaft Station at S65 – Roof

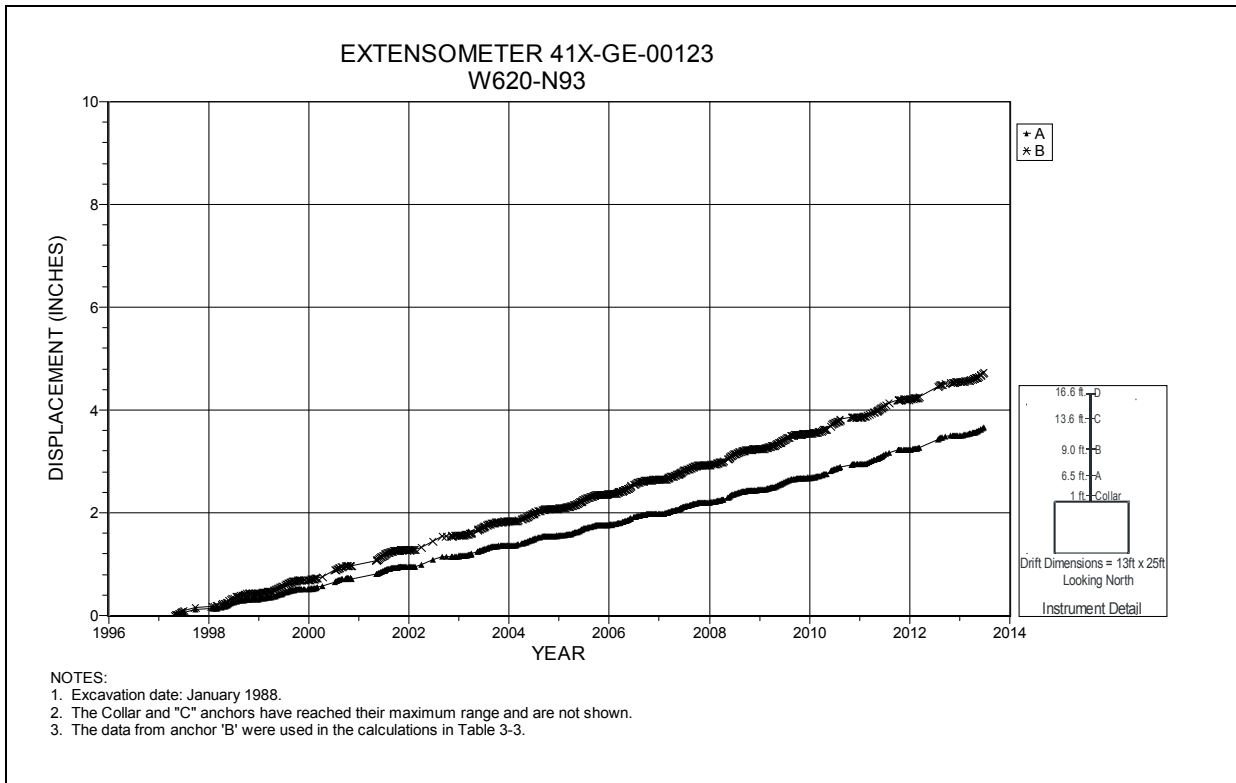

Figure 3-12 Extensometer 41X-GE-00123
Air Intake Shaft Station at N93 – Roof

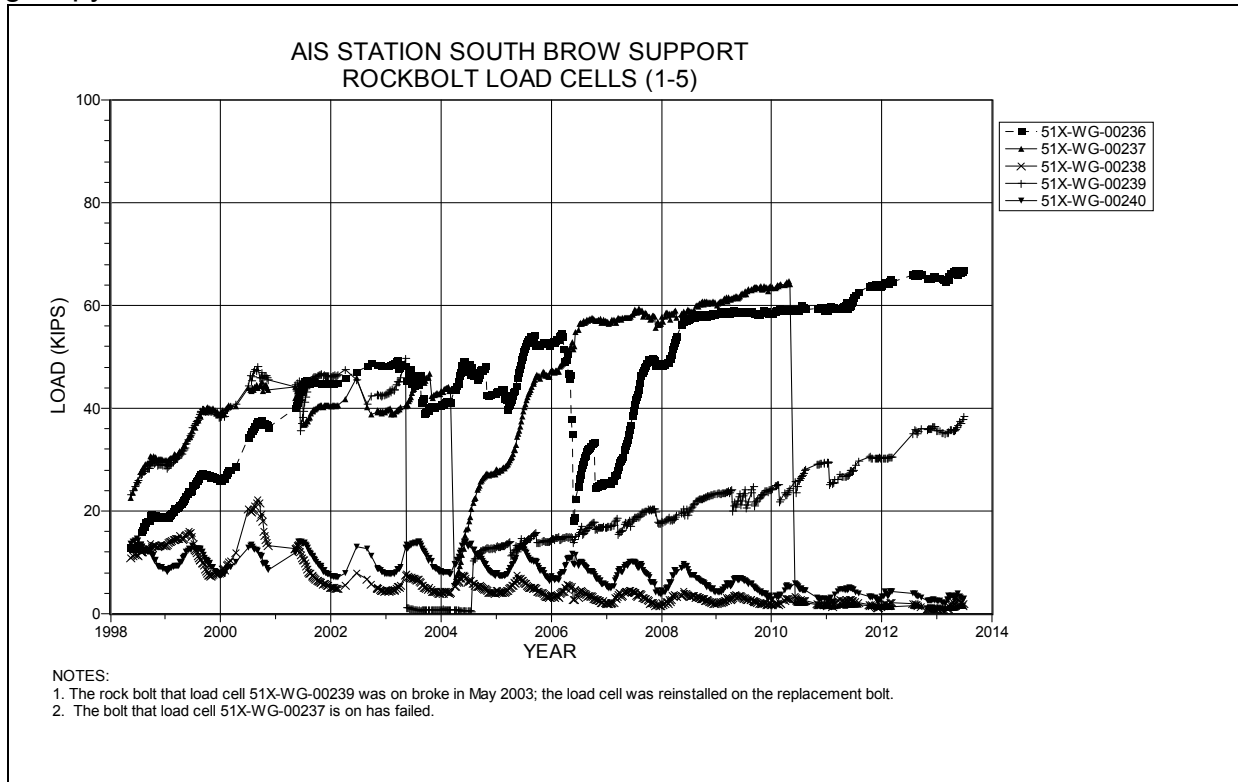

Figure 3-13 Rock Bolt Load Cells
Air Intake Shaft Station Brow – South Side Roof Bolts Set 1

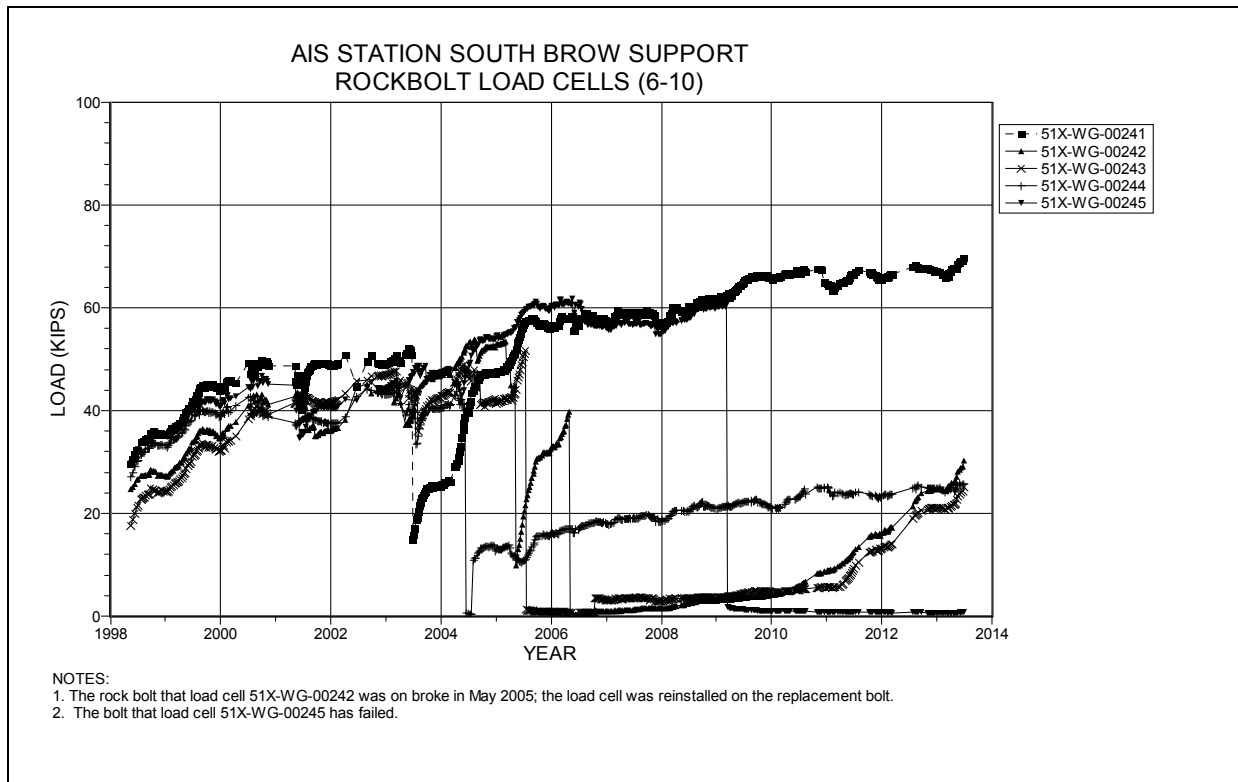

Figure 3-14 Rock Bolt Load Cells
Air Intake Shaft Station Brow – South Side Roof Bolts Set 2

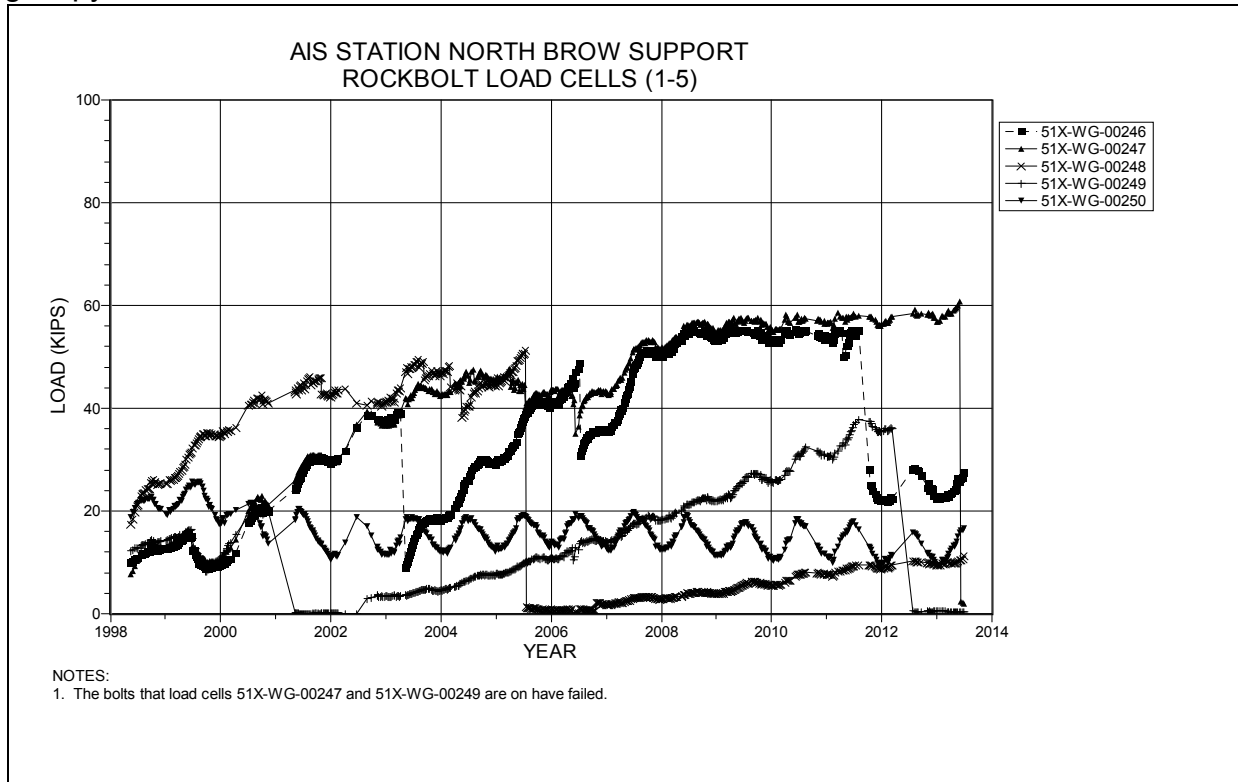

Figure 3-15 Rock Bolt Load Cells
Air Intake Shaft Station Brow – North Side Roof Bolts Set 1

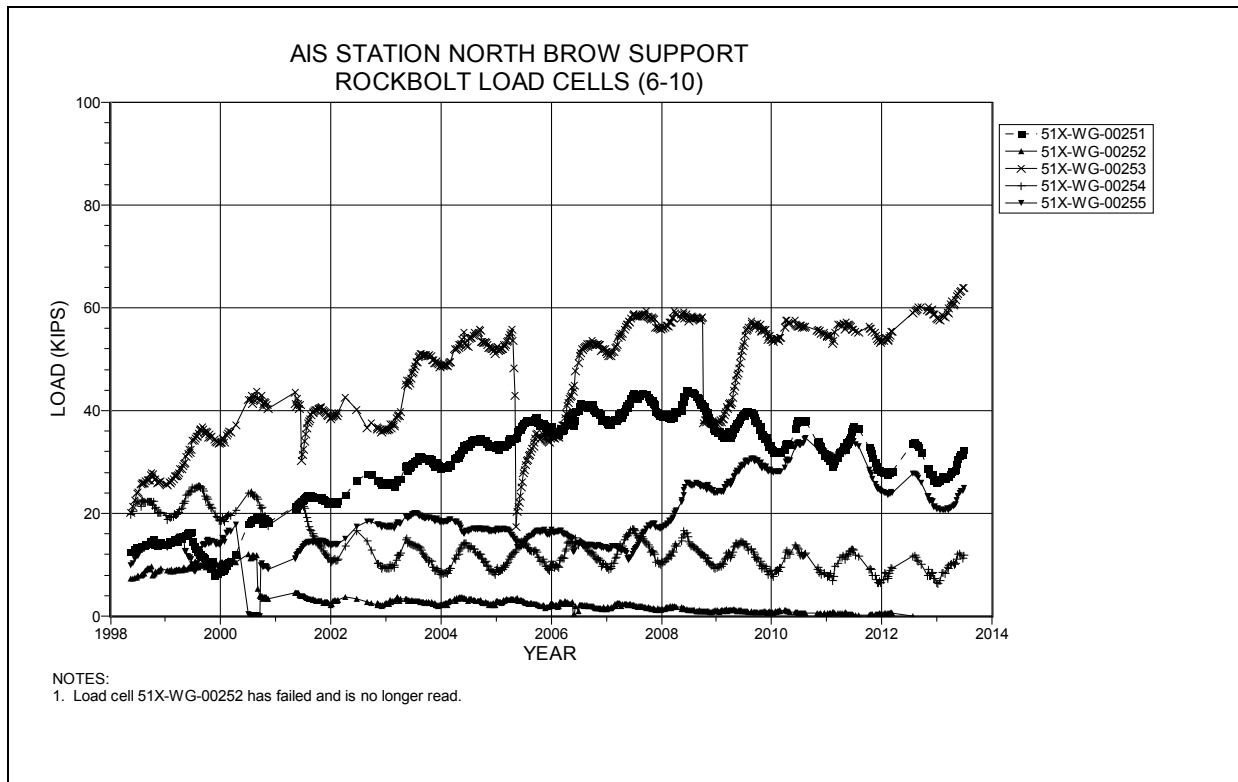

Figure 3-16 Rock Bolt Load Cells
Air Intake Shaft Station Brow – North Side Roof Bolts Set 2

4.0 Instrumentation Summary for the Access Drifts

This chapter presents the instrumentation data and data analyses for the access drifts throughout the WIPP underground. Table 4-1 provides the results of analyses performed on the instrument data including displacement, convergence rates, and rock bolt loading.

Figures 4-1 through 4-35 present data from borehole extensometers installed in the access drifts while Figures 4-36 through 4-264 present the convergence point data. Figure 4-265 through 4-270 presents data from joint meters installed at the S1950/E300 overcast and the access drifts. Figure 4-271 through 4-280 presents the data from rock bolt load cells installed in the E140 drift, the adjacent brows in E140-S1300 and at the E140-S1600 east brow.

Table 4-1
Access Drifts Data Analysis

Extensometers								
Field Tag	Location	Figure Number	Date of Last Reading	Collar Displacement Relative to Deepest Anchor (inches)	Displacement Rate 2012 to 2013 (in/year)	Displacement Rate ¹ 2011 to 2012 (in/year)	Rate Change Percent ¹	Comments
51X-GE-00355	E0-N300	4-1	06/28/13	5.990	0.7	0.6	17%	
51X-GE-00353	E0-N626	4-2	06/28/13	7.792	0.8	1.9	-58%	
51X-GE-00352	E0-N940	4-3	06/28/13	7.387	0.7	1.2	-42%	
51X-GE-00361	E0-N1266	4-4	06/28/13	11.460	0.7	1.5	-53%	
51X-GE-00105-3	E140-N150	4-5	04/16/13	4.141	0.3	0.7	-57%	
51X-GE-00364	E140-N1266	4-6	05/03/13	5.834	0.4	0.6	-33%	
51X-GE-00372	E140-S146	4-7	06/28/13	4.246	0.5	0.4	25%	Data taken from anchor 'B'.
51X-GE-00472	E140-S1000	4-8	06/25/13	6.214	0.4	0.4	0%	
51X-GE-00464	E140-S1025	4-9	06/25/13	5.291	0.2	0.4	-50%	
51X-GE-00333	E140 -S1075	4-10	12/03/12	5.903	0.5	0.7	-29%	Data taken from anchor 'B'.
51X-GE-00428-2	E140-S1150	4-11	06/27/13	2.592	2.2	3.2	-31%	
51X-GE-00335	E140-S1300	4-12	01/21/13	4.530	0.0	0.1	-100%	
51X-GE-00429	E140-S1450	4-13	06/26/13	2.625	1.5	1.9	-21%	
51X-GE-00430	E140-S1669	4-14	06/10/13	2.653	1.6	2.1	-24%	
51X-GE-00431	E140-S1775	4-15	06/26/13	2.469	1.7	1.3	31%	
51X-GE-00432	E140-S1850	4-16	06/26/13	3.138	1.9	2.2	-14%	
51X-GE-00433-2	E140-S2065	4-17	06/26/13	2.694	2.1	4.5	-53%	
51X-GE-00434	E140-S2265	4-18	06/26/13	1.835	0.8	2.5	-68%	
51X-GE-00435	E140-S2350	4-19	06/26/13	3.447	2.2	3.5	-37%	
51X-GE-00437	E140-S2635	4-20	04/18/13	1.852	2.1	N/A	N/A	See data plot Note 3.
51X-GE-00492	E140-S2750	4-21	06/24/13	3.920	0.3	0.3	0%	
51X-GE-00439	E140-S2916	4-22	06/26/13	0.657	0.5	0.9	-44%	
51X-GE-00396	E140-S3493	4-23	06/28/13	9.240	2.4	2.1	14%	
51X-GE-00373	E300-N1341	4-24	06/28/13	4.970	0.3	0.7	-57%	
51X-GE-00388	E300-N1266	4-25	06/28/13	4.083	0.6	0.7	-14%	
51X-GE-00374	E300-N1186	4-26	06/28/13	5.926	0.6	0.6	0%	
51X-GE-00474	S1000-E120	4-27	06/26/13	1.477	0.0	0.1	-100%	
51X-GE-00473	S1000-E160	4-28	06/26/13	1.287	0.1	0.1	0%	
51X-GE-00462	S1300-E120	4-29	06/26/13	0.854	0.0	0.0	0%	

**Table 4-1
Access Drifts Data Analysis (Continued)**

Extensometers (continued)								
Field Tag	Location	Figure Number	Date of Last Reading	Collar Displacement Relative to Deepest Anchor (inches)	Displacement Rate ¹ 2012 to 2013 (in/year)	Displacement Rate ¹ 2011 to 2012 (in/year)	Rate Change Percent ¹	Comments
51X-GE-00463	S1300-E160	4-30	08/30/12	5.208	N/A	0.44	N/A	Inst. failed after 8/30/12.
51X-GE-00442	S1600-E120	4-31	06/26/13	1.233	0.1	0.1	0%	
51X-GE-00500/502 ²	S2750-W93	4-32	06/24/13	0.075	0.3	2.9	-90%	See footnote 2.
51X-GE-00501-2	S2750-W285	4-33	06/24/13	2.316	5.9	N/A	N/A	
51X-GE-00415	W170-S2998	4-34	06/20/13	11.290	3.0	4.2	N/A	
51X-GE-00490	W30-S2750	4-35	06/03/13	4.600	0.8	0.7	14%	

¹ N/A – Insufficient data available to perform the calculation. This is usually due to the inability to read the instruments because of activities such as: the temporary removal of an instrument due to floor, rib or back trimming; locations blocked by equipment or waste disposal, installation timing, etc.

² GE500 data were used for the 2011-2012 reporting period and the 2012-2013 data came from GE502. The area was heavily bolted prior to GE502's installation.

**Table 4-1
Access Drifts Data Analysis (Continued)**

Convergence Points									
Field Tag	Location	Figure Number	Last Reading 2012-2013		Cumulative Displacement (inches)	Closure Rate 2012 to 2013 (in/year)	Closure Rate 2011 to 2012 (in/year)	Rate Change Percent	Comments
			Date	Inches					
CORE-W10 A-C	Core Storage W10	4-36	05/07/13	23.729	23.729	0.9	0.9	0%	
CORE-W20 A-C	Core Storage W20	4-36	05/07/13	22.570	22.570	0.9	0.9	0%	
CORE-W30 A-C	Core Storage W30	4-36	05/07/13	23.820	23.820	1.0	1.0	0%	
CORE-W51 A-C	Core Storage W51	4-36	05/07/13	27.654	27.654	1.2	1.3	-8%	
CORE-W62 A-C	Core Storage W62	4-36	05/08/13	28.932	28.932	1.2	1.4	-14%	
CORE-W73 A-C	Core Storage W73	4-36	05/08/13	29.205	29.205	1.2	1.4	-14%	
CORE-W101 A-C	Core Storage W101	4-36	05/08/13	28.152	28.152	1.1	1.3	-15%	
CORE-W117 A-C	Core Storage W117	4-36	05/08/13	25.272	25.272	1.0	1.1	-9%	
CORE-W133 A-C	Core Storage W133	4-36	10/30/12	20.677	20.677	0.9	0.9	0%	Instrument is inaccessible.
E0-N75 A-C	E0-N75	4-37	06/05/13	21.785	21.785	2.0	1.8	11%	
E0-N75 B-D	E0-N75	4-37	06/05/13	15.035	15.035	1.2	1.1	9%	
E0-N225-2 A-C	E0-N225	4-38	06/04/13	21.504	21.551	1.9	1.7	12%	
E0-N225-2 B-D	E0-N225	4-38	06/04/13	4.435	16.740	1.4	1.3	8%	

Table 4-1
Access Drifts Data Analysis (Continued)

Convergence Points (Continued)									
Field Tag	Location	Figure Number	Last Reading 2012-2013		Cumulative Displacement (inches)	Closure Rate 2012 to 2013 (in/year)	Closure Rate 2011 to 2012 (in/year)	Rate Change Percent	Comments
			Date	Inches					
E0-N300-6 A-C	E0-N300	4-39	06/05/13	5.036	56.081	1.8	1.7	6%	
E0-N460-3 A-C	E0-N460	4-40	06/05/13	25.789	45.878	2.3	2.2	5%	
E0-N562 A-C	E0-N562	4-41	06/05/13	19.816	19.816	2.1	2.2	-5%	
E0-N562 B-D	E0-N562	4-41	06/05/13	16.578	16.578	1.7	1.5	13%	
E0-N626-4 A-C	E0-N626	4-42	06/05/13	24.810	65.769	2.3	3.1	-26%	
E0-N686 A-C	E0-N686	4-43	06/05/13	27.073	27.073	2.4	4.0	-40%	
E0-N686 B-D	E0-N686	4-43	06/05/13	15.254	15.254	1.4	1.3	8%	
E0-N780-2 A-C	E0-N780	4-44	06/05/13	21.303	41.725	2.1	2.0	5%	
E0-N940-5 A-C	E0-N940	4-45	06/05/13	21.836	69.888	2.2	2.4	-8%	
E0-N1110-5 A-C	E0-N1110	4-46	06/05/13	14.639	49.063	1.3	1.4	-7%	
E0-N1266-4 A-C	E0-N1266	4-47	06/05/13	23.641	60.548	2.2	2.1	5%	
E140-N5-7 A-C	E140-N5	4-48	06/11/13	0.566	47.459	3.0	2.4	25%	
E140-N5-3 B-D	E140-N5	4-48	06/11/13	18.818	34.059	1.5	1.1	36%	
E140-N150-6 A-C	E140-N150	4-49	06/11/13	0.424	31.170	2.2	1.8	22%	
E140-N220-4 A-C	E140-N220	4-50	06/11/13	0.671	42.828	3.6	2.5	44%	
E140-N355-2 A-C	E140-N355	4-51	06/11/13	14.477	23.021	2.5	2.4	4%	
E140-N355 B-D	E140-N355	4-51	06/11/13	18.962	18.962	1.8	1.6	13%	
E140-N460-3 A-C	E140-N460	4-52	06/11/13	23.755	44.586	2.1	2.1	0%	
E140-N562-2 A-C	E140-N562	4-53	06/11/13	23.509	35.326	2.7	2.6	4%	
E140-N562-2 B-D	E140-N562	4-53	06/11/13	16.502	24.698	1.8	1.6	13%	
E140-N626-3 A-C	E140-N626	4-54	06/11/13	32.165	64.735	3.5	3.8	-8%	
E140-N626-4 B-D	E140-N626	4-54	06/11/13	15.740	37.047	1.6	1.5	7%	
E140-N686-2 A-C	E140-N686	4-55	06/11/13	25.622	38.761	2.6	3.1	-16%	
E140-N686-2 B-D	E140-N686	4-55	06/11/13	15.872	24.706	1.7	1.6	6%	
E140-N780-2 A-C	E140-N780	4-56	06/11/13	30.252	62.009	2.8	3.1	-10%	
E140-N940-2 A-C	E140-N940	4-57	06/11/13	29.216	29.216	3.4	4.6	-26%	The initial installation was at N952.
E140-N1100-2 A-C	E140-N1100	4-58	06/11/13	13.949	37.817	1.5	1.7	-12%	
E140-N1266-3 A-C	E140-N1266	4-59	06/11/13	22.335	60.090	2.3	2.5	-8%	

Table 4-1
Access Drifts Data Analysis (Continued)

Convergence Points (Continued)									
Field Tag	Location	Figure Number	Last Reading 2012-2013		Cumulative Displacement (inches)	Closure Rate 2012 to 2013 (in/year)	Closure Rate 2011 to 2012 (in/year)	Rate Change Percent	Comments
			Date	Inches					
E140-N1266-4 B-D	E140-N1266	4-59	06/11/13	11.269	33.274	1.3	1.3	0%	
E140-N1420-2 A-C	E140-N1420	4-60	04/16/13	14.931	31.401	1.4	1.9	-26%	
E140-S90-4 A-C	E140-S90	4-61	06/25/13	11.548	29.261	2.1	1.5	40%	
E140-S262-5 A-C	E140-S262	4-62	06/25/13	1.303	38.324	2.2	2.1	5%	
E140-S262-3 B-D	E140-S262	4-62	06/25/13	22.352	23.705	1.3	1.0	30%	
E140-S460-6 A-C	E140-S460	4-63	06/25/13	5.035	55.771	2.1	2.1	0%	
E140-S460-2 B-D	E140-S460	4-63	06/25/13	28.355	34.299	1.3	1.2	8%	
E140-S550-6 A-C	E140-S550	4-64	06/25/13	4.713	46.680	1.9	1.9	0%	
E140-S550-4 B-D	E140-S550	4-64	06/25/13	31.177	39.819	1.6	1.5	7%	
E140-S700-8 A-D	E140-S700	4-65	06/25/13	5.631	35.671	2.2	2.2	0%	
E140-S700-6 B-C	E140-S700	4-66	06/25/13	8.257	38.289	2.2	2.8	-21%	
E140-S700-6 E-F	E140-S700	4-67	06/25/13	4.657	24.654	1.4	1.4	0%	
E140-S850-10 A-C	E140-S850	4-68	06/25/13	0.669	58.405	2.6	2.5	4%	
E140-S850-4 B-D	E140-S850	4-69	06/25/13	21.113	37.060	1.4	1.3	8%	
E140-S1000-4 A-C	E140-S1000	4-70	06/25/13	0.597	40.944	2.3	1.4	64%	
E140-S1025-5 A-C	E140-S1025	4-71	06/25/13	0.602	28.009	2.3	2.0	15%	
E140-S1075-5 A-E	E140-S1075	4-72	06/25/13	0.862	29.664	3.2	2.5	28%	
E140-S1075-5 B-D	E140-S1075	4-73	06/25/13	0.381	22.472	1.4	1.2	17%	
E140-S1075-5 H-F	E140-S1075	4-73	06/25/13	0.570	21.890	2.1	1.7	24%	
E140-S1075-2 C-G	E140-S1075	4-74	06/25/13	19.638	20.460	1.4	1.4	0%	
E140-S1150-5 A-G	E140-S1150	4-75	06/25/13	1.364	71.538	5.1	4.2	21%	
E140-S1150-7 B-F	E140-S1150	4-76	05/22/13	0.537	32.994	3.2	2.1	52%	
E140-S1150 C-K	E140-S1150	4-77	06/25/13	19.886	19.886	1.3	1.3	0%	
E140-S1150-2 D-J	E140-S1150	4-77	06/25/13	21.360	39.281	1.6	1.6	0%	
E140-S1150-2 E-I	E140-S1150	4-77	06/25/13	19.273	20.134	1.4	1.5	-7%	
E140-S1150-6 L-H	E140-S1150	4-78	06/25/13	0.598	26.396	2.3	2.1	10%	
E140-S1225-5 A-E	E140-S1225	4-79	06/25/13	1.229	37.724	4.6	4.0	15%	

Table 4-1
Access Drifts Data Analysis (Continued)

Convergence Points (Continued)									
Field Tag	Location	Figure Number	Last Reading 2012-2013		Cumulative Displacement (inches)	Closure Rate 2012 to 2013 (in/year)	Closure Rate 2011 to 2012 (in/year)	Rate Change Percent	Comments
			Date	Inches					
E140-S1225-2 C-G	E140-S1225	4-79	06/25/13	27.812	28.719	2.2	2.3	-4%	
E140-S1225-5 B-D	E140-S1225	4-80	06/25/13	0.550	36.474	2.1	3.7	-43%	
E140-S1225-4 H-F	E140-S1225	4-80	06/25/13	0.779	26.162	2.9	2.5	16%	
E140-S1300-5 A-C	E140-S1300	4-81	06/25/13	0.523	38.466	1.9	1.7	12%	
E140-S1378-4 A-E	E140-S1378	4-82	06/25/13	1.289	43.830	4.5	3.5	29%	
E140-S1378-4 B-D	E140-S1378	4-83	06/25/13	0.657	30.195	2.3	1.9	21%	
E140-S1378-4 H-F	E140-S1378	4-83	06/25/13	1.423	47.285	5.0	3.8	32%	
E140-S1378 C-G	E140-S1378	4-84	06/25/13	24.034	28.204	1.8	1.7	6%	
E140-S1450-6 A-G	E140-S1450	4-85	06/25/13	1.234	82.041	4.3	3.8	13%	
E140-S1450-4 B-F	E140-S1450	4-86	06/25/13	0.373	47.861	1.3	3.2	-59%	
E140-S1450-3 I-E	E140-S1450	4-87	06/25/13	4.239	22.331	1.5	1.5	0%	
E140-S1456 K-C	E140-S1456	4-87	06/25/13	22.641	22.641	1.5	1.5	0%	
E140-S1450-4 L-H	E140-S1450	4-88	06/25/13	0.990	42.810	3.5	3.0	17%	
E140-S1456-2 D-J	E140-S1456	4-89	06/25/13	25.756	47.051	2.0	1.9	5%	
E140-S1534-4 A-E	E140-S1534	4-90	06/25/13	0.947	54.430	3.3	3.1	6%	
E140-S1534-2 C-G	E140-S1534	4-90	06/25/13	22.781	24.252	1.7	1.7	0%	
E140-S1534-5 B-D	E140-S1534	4-91	06/25/13	0.779	35.326	2.7	2.5	8%	
E140-S1534-4 H-F	E140-S1534	4-92	06/25/13	0.824	38.762	2.9	2.6	12%	
E140-S1600-7 A-C	E140-S1600	4-93	06/25/13	0.781	42.727	2.7	2.1	29%	
E140-S1687-4 A-E	E140-S1687	4-94	06/25/13	1.132	50.271	3.8	3.6	6%	
E140-S1687 C-G	E140-S1687	4-94	06/25/13	25.365	25.365	2.0	1.9	5%	
E140-S1687-4 B-D	E140-S1687	4-95	06/25/13	0.511	37.253	1.8	2.4	-25%	
E140-S1687-4 H-F	E140-S1687	4-95	06/25/13	0.837	37.605	2.8	2.9	-3%	
E140-S1775-4 A-G	E140-S1775	4-96	06/25/13	1.288	69.474	4.3	4.3	0%	
E140-S1775-5 B-F	E140-S1775	4-97	06/25/13	1.252	58.665	4.2	3.9	8%	
E140-S1775-4 L-H	E140-S1775	4-97	06/25/13	0.325	32.910	1.1	2.3	-52%	
E140-S1775 C-K	E140-S1775	4-98	06/25/13	24.090	24.090	1.7	1.7	0%	

Table 4-1
Access Drifts Data Analysis (Continued)

Convergence Points (Continued)									
Field Tag	Location	Figure Number	Last Reading 2012-2013		Cumulative Displacement (inches)	Closure Rate 2012 to 2013 (in/year)	Closure Rate 2011 to 2012 (in/year)	Rate Change Percent	Comments
			Date	Inches					
E140-S1775-2 D-J	E140-S1775	4-98	06/25/13	26.357	27.608	2.5	2.2	14%	
E140-S1775-3 I-E	E140-S1775	4-98	06/25/13	11.326	25.547	1.9	1.9	0%	
E140-S1862-4 A-E	E140-S1862	4-99	06/25/13	1.287	54.285	4.3	3.9	10%	
E140-S1862-3 C-G	E140-S1862	4-99	06/25/13	19.550	25.855	2.3	2.2	5%	
E140-S1862-4 B-D	E140-S1862	4-100	06/25/13	1.224	49.885	4.1	4.1	0%	
E140-S1862-4 H-F	E140-S1862	4-100	06/25/13	0.689	27.042	2.3	2.0	15%	
E140-S1950-7 A-C	E140-S1950	4-101	06/25/13	1.309	57.699	4.4	3.3	33%	
E140-S2007-8 A-C	E140-S2007	4-102	06/25/13	1.603	46.130	5.4	4.6	17%	
E140-S2065-7 A-C	E140-S2065	4-103	06/25/13	1.604	54.370	5.4	5.5	-2%	
E140-S2065-2 B-D	E140-S2065	4-103	06/25/13	19.547	26.195	2.2	2.2	0%	
E140-S2122-7 A-C	E140-S2122	4-104	06/25/13	0.513	50.753	3.0	5.0	-40%	
E140-S2275-7 A-C	E140-S2275	4-105	06/25/13	1.613	80.550	5.4	7.2	-25%	
E140-S2275 B-D	E140-S2275	4-105	06/25/13	28.193	28.193	2.4	2.4	0%	
E140-S2350-7 A-C	E140-S2350	4-106	06/25/13	1.731	84.444	5.7	6.5	-12%	
E140-S2350-2 B-D	E140-S2350	4-106	06/25/13	29.822	36.713	2.6	2.6	0%	
E140-S2425-6 A-C	E140-S2425	4-107	06/25/13	1.477	56.983	4.9	4.8	2%	
E140-S2425 B-D	E140-S2425	4-107	06/25/13	29.431	29.431	2.6	2.6	0%	
E140-S2520-4 A-C	E140-S2520	4-108	06/24/13	1.266	42.042	4.2	3.6	17%	
E140-S2634-2 A-C	E140-S2634	4-109	06/24/13	1.766	58.741	5.9	5.8	2%	
E140-S2634 B-D	E140-S2634	4-109	06/24/13	23.489	23.489	2.6	2.6	0%	
E140-S2750-4 A-C	E140-S2750	4-110	06/24/13	1.064	27.399	3.6	3.1	16%	
E140-S2833-3 A-C	E140-S2833	4-111	06/24/13	20.965	41.764	4.7	5.1	-8%	
E140-S2833 B-D	E140-S2833	4-111	06/24/13	20.600	20.600	2.3	2.2	5%	
E140-S2915-3 A-C	E140-S2915	4-112	06/24/13	15.005	41.221	2.7	3.1	-13%	
E140-S2915 B-D	E140-S2915	4-112	06/24/13	22.275	22.275	2.4	2.4	0%	
E140-S2998-3 A-C	E140-S2998	4-113	06/25/13	16.176	43.331	3.5	3.7	-5%	
E140-S2998 B-D	E140-S2998	4-113	06/25/13	20.409	20.409	2.1	2.1	0%	

Table 4-1
Access Drifts Data Analysis (Continued)

Convergence Points (Continued)									
Field Tag	Location	Figure Number	Last Reading 2012-2013		Cumulative Displacement (inches)	Closure Rate 2012 to 2013 (in/year)	Closure Rate 2011 to 2012 (in/year)	Rate Change Percent	Comments
			Date	Inches					
E140-S3080-2 A-C	E140-S3080	4-114	06/24/13	14.943	31.082	3.7	3.5	6%	
E140-S3195-2 A-C	E140-S3195	4-115	06/24/13	17.528	43.783	4.3	4.1	5%	
E140-S3195 B-D	E140-S3195	4-115	06/24/13	20.232	20.232	2.1	2.1	0%	
E140-S3295-2 A-C	E140-S3295	4-116	06/25/13	10.807	18.512	2.4	2.5	-4%	
E140-S3325 A-C	E140-S3325	4-117	06/25/13	18.043	18.043	2.3	2.4	-4%	
E140-S3395-2 A-C	E140-S3395	4-118	06/25/13	15.909	31.067	3.3	3.6	-8%	
E140-S3395 B-D	E140-S3395	4-118	06/25/13	14.468	14.468	1.7	1.7	0%	
E140-S3480-2 A-C	E140-S3480	4-119	06/25/13	17.945	32.245	4.3	4.2	2%	
E140-S3480 B-D	E140-S3480	4-119	06/25/13	14.833	14.833	1.8	1.8	0%	
E140-S3565-2 A-C	E140-S3565	4-120	06/25/13	13.444	24.772	3.3	3.1	6%	
E140-S3565 B-D	E140-S3565	4-120	06/25/13	14.077	14.077	1.6	1.6	0%	
E140-S3650-2 A-C	E140-S3650	4-121	06/10/13	8.890	15.510	1.9	1.9	0%	
E300-N45 A-E	E300-N45	4-122	01/28/13	32.881	32.881	1.9	1.3	46%	
E300-N45 C-G	E300-N45	4-122	11/27/12	24.273	24.273	1.7	1.2	42%	
E300-N45 H-F	E300-N45	4-122	01/28/13	29.539	29.539	1.8	1.2	50%	
E300-N170-2 A-E	E300-N170	4-123	01/28/13	10.980	33.474	2.3	1.7	35%	
E300-N170-2 C-G	E300-N170	4-123	01/28/13	11.260	26.104	1.8	1.3	38%	
E300-N170-2 H-F	E300-N170	4-123	01/28/13	10.235	30.295	2.3	1.6	44%	
E300-N250-3 A-C	E300-N250	4-124	01/28/13	10.651	39.605	1.9	1.6	19%	
E300-N1262-4 A-C	E300-N1262	4-125	06/13/13	1.779	23.845 ²	2.5	N/A	N/A	Inaccessible '11-'12.
E300-N1341-3 A-C	E300-N1341	4-126	06/13/13	1.680	22.278	2.4	N/A	N/A	Inaccessible '11-'12.
E300-S45-2 A-E	E300-S45	4-127	01/28/13	27.204	27.204	2.3	1.2	92%	See data plot Note 2.
E300-S45-2 B-D	E300-S45	4-127	01/28/13	25.191	25.191	2.8	1.5	87%	
E300-S45 C-G	E300-S45	4-127	01/28/13	20.517	20.517	1.7	0.8	113%	
E300-S45-2 H-F	E300-S45	4-127	01/28/13	23.249	23.249	1.7	1.0	70%	
E300-S90-2 A-C	E300-S90	4-128	05/28/13	0.207	20.277	1.4	0.7	100%	
E300-S250-2 A-C	E300-S250	4-129	05/28/13	9.969	14.354	0.8	0.7	14%	

Table 4-1
Access Drifts Data Analysis (Continued)

Convergence Points (Continued)									
Field Tag	Location	Figure Number	Last Reading 2012-2013		Cumulative Displacement (inches)	Closure Rate 2012 to 2013 (in/year)	Closure Rate 2011 to 2012 (in/year)	Rate Change Percent	Comments
			Date	Inches					
E300-S250-2 B-D	E300-S250	4-129	05/28/13	10.667	14.713	0.8	0.6	33%	
E300-S700-2 A-C	E300-S700	4-130	05/28/13	3.372	23.102	1.3	1.4	-7%	
E300-S850-2 A-E	E300-S850	4-131	05/28/13	1.757	16.839	0.7	0.8	-13%	
E300-S850-2 B-D	E300-S850	4-131	05/28/13	1.499	12.800	0.6	0.6	0%	
E300-S850-2 C-G	E300-S850	4-131	05/28/13	9.916	19.194	0.8	0.7	14%	
E300-S850-2 H-F	E300-S850	4-131	05/28/13	1.317	11.780	0.6	0.5	20%	
E300-S1000-2 A-C	E300-S1000	4-132	05/28/13	2.415	21.960	1.0	1.0	0%	
E300-S1150-4 A-E	E300-S1150	4-133	05/28/13	5.758	22.837	2.0	2.5	-20%	
E300-S1150-4 B-D	E300-S1150-4	4-134	05/28/13	1.848	13.953	0.7	0.8	-13%	
E300-S1150-4 H-F	E300-S1150	4-134	05/28/13	2.046	13.802	0.8	0.9	-11%	
E300-S1150-2 C-G	E300-S1150	4-135	05/28/13	12.199	22.655	1.0	1.0	0%	
E300-S1300-2 A-C	E300-S1300	4-136	05/28/13	4.414	17.948	1.7	1.8	-6%	
E300-S1450-2 A-C	E300-S1450	4-137	05/28/13	4.366	13.348	1.8	1.9	-5%	
E300-S1450 B-D	E300-S1450	4-137	05/28/13	14.095	14.095	1.3	1.3	0%	
E300-S1687-2 A-C	E300-S1687	4-138	05/28/13	3.112	12.969	1.4	1.3	8%	
E300-S1687 B-D	E300-S1687	4-138	05/28/13	13.958	13.958	1.3	1.2	8%	
E300-S1775-2 A-C	E300-S1775	4-139	05/28/13	3.738	12.533	1.6	1.6	0%	
E300-S1775 B-D	E300-S1775	4-139	05/28/13	14.236	14.236	1.3	1.2	8%	
E300-S1862-2 A-C	E300-S1862	4-140	05/28/13	4.672	14.125	2.0	2.1	-5%	
E300-S1862 B-D	E300-S1862	4-140	05/28/13	15.576	15.576	1.4	1.4	0%	
E300-S2065-2 A-C	E300-S2065	4-141	05/28/13	4.598	15.709	2.1	1.9	11%	
E300-S2065 B-D	E300-S2065	4-141	05/28/13	20.130	20.130	1.9	2.0	-5%	
E300-S2275-2 A-C	E300-S2275	4-142	05/28/13	7.074	20.500	2.9	3.1	-6%	
E300-S2275 B-D	E300-S2275	4-142	05/28/13	23.508	23.508	2.2	2.3	-4%	
E300-S2350-2 A-C	E300-S2350	4-143	05/28/13	9.669	25.233	3.8	4.3	-12%	
E300-S2350 B-D	E300-S2350	4-143	05/28/13	24.028	24.028	2.2	2.2	0%	
E300-S2425-2 A-C	E300-S2425	4-144	05/28/13	7.873	24.095	3.1	3.4	-9%	

Table 4-1
Access Drifts Data Analysis (Continued)

Convergence Points (Continued)									
Field Tag	Location	Figure Number	Last Reading 2012-2013		Cumulative Displacement (inches)	Closure Rate ¹ 2012 to 2013 (in/year)	Closure Rate 2011 to 2012 (in/year)	Rate Change Percent ¹	Comments
			Date	Inches					
E300-S2425 B-D	E300-S2425	4-144	05/28/13	24.004	24.004	2.1	2.1	0%	
E300-S2634-2 A-C	E300-S2634	4-145	05/28/13	5.115	18.500	2.1	2.3	-9%	
E300-S2634 B-D	E300-S2634	4-145	05/28/13	18.966	18.966	2.1	2.1	0%	
E300-S2833-2 A-C	E300-S2833	4-146	05/28/13	4.566	20.858	2.1	1.9	11%	
E300-S2833 B-D	E300-S2833	4-146	05/28/13	19.659	19.659	2.2	2.1	5%	
E300-S2916-4 A-C	E300-S2916	4-147	05/28/13	5.995	31.065	3.0	2.4	25%	
E300-S2916 B-D	E300-S2916	4-147	05/28/13	22.049	22.049	2.6	2.4	8%	
E300-S2998-4 A-C	E300-S2998	4-148	05/28/13	7.738	42.488	3.5	3.0	17%	
E300-S2998 B-D	E300-S2998	4-148	05/28/13	22.076	22.076	2.7	2.7	0%	
E300-S3195 A-C	E300-S3195	4-149	05/28/13	25.837	25.837	3.4	3.4	0%	
E300-S3195 B-D	E300-S3195	4-149	05/28/13	19.614	19.614	2.0	2.0	0%	
E300-S3480 A-C	E300-S3480	4-150	05/28/13	14.451	14.451	2.3	2.2	5%	
E300-S3480 B-D	E300-S3480	4-150	05/28/13	11.110	11.110	1.8	1.7	6%	
N140-E90-2 A-C	N140-E90	4-151	06/11/13	4.161	18.298	0.8	0.8	0%	
N140-E90 B-D	N140-E90	4-151	06/11/13	19.745	19.745	1.0	0.9	11%	
N215-W500-2 A-C	N215-W500	4-152	06/12/13	13.565	31.894	1.2	1.4	-14%	
N215-W500-2 B-D	N215-W500	4-152	06/12/13	13.957	20.775	0.9	0.9	0%	
N215-W620-2 A-C	N215-W620	4-153	06/12/13	10.373	26.591	1.0	1.2	-17%	
N250-E220-2 A-E	N250-E220	4-154	01/28/13	16.331	39.958	2.7	2.4	13%	
N250-E220-2 B-D	N250-E220	4-154	01/28/13	11.198	36.140	1.8	1.6	13%	
N250-E220 C-G	N250-E220	4-154	01/28/13	26.998	26.998	1.5	1.3	15%	
N250-E220-2 H-F	N250-E220	4-154	01/28/13	9.863	28.288	1.7	1.5	13%	
N300-W170-2 A-C	N300-W170	4-155	06/12/13	16.231	38.491	1.6	1.7	-6%	
N300-W170-2 B-D	N300-W170	4-155	06/12/13	18.383	26.578	1.3	1.3	0%	
N460-E70-3 A-C	N460-E70	4-156	06/05/13	16.961	33.407	1.7	1.6	6%	
N460-E70-2 B-D	N460-E70	4-156	06/05/13	17.724	29.422	1.6	1.4	14%	
N780-E70 A-C	N780-E70	4-157	12/06/12	13.737	13.737	N/A	1.3	N/A	Accessible only once during 2012-2013.

Table 4-1
Access Drifts Data Analysis (Continued)

Convergence Points (Continued)									
Field Tag	Location	Figure Number	Last Reading 2012-2013		Cumulative Displacement (inches)	Closure Rate 2012 to 2013 (in/year)	Closure Rate 2011 to 2012 (in/year)	Rate Change Percent	Comments
			Date	Inches					
N780-E70 B-D	N780-E70	4-157	12/06/12	13.523	13.523	N/A	1.0	N/A	
S90-W120 A-C	S90-W120	4-158	05/07/13	8.707	8.707	0.6	0.7	-14%	
S90-W120 B-D	S90-W120	4-158	05/07/13	9.275	9.275	0.7	0.6	17%	
S90-W400-2 A-C	S90-W400	4-159	05/07/13	5.289	18.638	0.6	0.6	0%	
S90-W400-2 B-D	S90-W400	4-159	05/07/13	10.179	18.073	0.6	0.6	0%	
S90-W590-2 A-C	S90-W590	4-160	05/07/13	5.055	14.384	0.6	0.6	0%	
S90-W590-2 B-D	S90-W590	4-160	05/07/13	9.688	13.495	0.6	0.5	20%	
S90-W620 A-C	S90-W620	4-161	05/07/13	27.255	27.255	1.0	1.1	-9%	
S90-W770 A-C	S90-W770	4-162	05/07/13	19.041	19.041	0.9	0.9	0%	
S90-W770-3 B-D	S90-W770	4-162	05/07/13	4.151	17.472	0.8	0.8	0%	
S90-W905 A-C	S90-W905	4-163	05/07/13	16.156	16.156	1.0	1.1	-9%	
S105-W920 A-C	S105-W920	4-164	05/07/13	5.063	5.063	1.0	1.0	0%	
S700-E55-2 A-C	S700-E55	4-165	06/26/13	6.162	10.296	1.8	2.0	-10%	
S700-E55-2 B-D	S700-E55	4-165	06/26/13	3.906	8.048	1.1	1.2	-8%	
S700-E180 A-C	S700-E180	4-166	06/27/13	13.844	13.844	1.9	2.0	-5%	
S700-E180 B-D	S700-E180	4-166	06/27/13	7.978	7.978	1.1	1.1	0%	
S700-E205-3 A-C	S700-E205	4-167	06/27/13	13.694	31.123	1.9	2.0	-5%	
S700-W98-3 A-C	S700-W98	4-168	06/26/13	3.116	27.457	2.1	2.7	-22%	
S1000-E58-4 A-C	S1000-E58	4-169	06/26/13	10.936	26.402	1.3	1.4	-7%	
S1000-E58-2 B-D	S1000-E58	4-169	06/26/13	20.024	22.986	1.2	1.2	0%	
S1000-E120-3 A-C	S1000-E120	4-170	06/26/13	9.666	18.106	1.1	1.2	-8%	
S1000-E160-3 A-C	S1000-E0160	4-171	06/26/13	5.100	13.310	0.9	0.9	0%	
S1000-W98-2 A-C	S1000-W98	4-172	06/27/13	17.848	36.596	2.1	2.0	5%	
S1300-E24 A-C	S1300-E24	4-173	06/26/13	24.296	24.296	1.3	1.4	-7%	
S1300-E120 A-C	S1300-E120	4-174	06/26/13	16.186	16.186	1.0	1.1	-9%	
S1300-E160 A-C	S1300-E160	4-175	06/26/13	25.947	25.947	1.8	2.0	-10%	
S1300-W100-3 A-C	S1300-W100	4-176	06/26/13	16.017	40.020	1.9	2.5	-24%	

Table 4-1
Access Drifts Data Analysis (Continued)

Convergence Points (Continued)									
Field Tag	Location	Figure Number	Last Reading 2012-2013		Cumulative Displacement (inches)	Closure Rate 2012 to 2013 (in/year)	Closure Rate 2011 to 2012 (in/year)	Rate Change Percent	Comments
			Date	Inches					
S1600-E110-2 A-C	S1600-E110	4-177	06/26/13	0.206	16.928	1.5	1.1	36%	
S1600-E170-2 A-C	S1600-E170	4-178	06/26/13	0.225	18.536	1.7	1.2	42%	
S1950-E113-4 A-C	S1950-E113	4-179	06/26/13	11.002	14.878	1.2	1.3	-8%	
S1950-E281-3 A-C	S1950-E281	4-180	06/24/13	16.812	23.354	1.2	1.3	-8%	
S1950-E284-3 A-C	S1950-E284	4-181	06/24/13	17.164	23.776	1.2	1.3	-8%	
S2180-E55-3 A-C	S2180-E55	4-182	06/10/13	8.885	19.732	2.2	2.2	0%	
S2180-E55 B-D	S2180-E55	4-182	06/10/13	17.675	17.675	1.9	1.9	0%	
S2180-E220 A-C	S2180-E220	4-183	06/10/13	17.575	17.575	1.7	1.7	0%	
S2180-E220 B-D	S2180-E220	4-183	06/10/13	19.510	19.510	2.0	1.9	5%	
S2180-W100-3 A-C	S2180-W100	4-184	06/10/13	8.926	27.109	3.4	3.4	0%	
S2180-W100-2 B-D	S2180-W100	4-184	06/10/13	16.844	16.985	2.1	2.1	0%	
S2520-E220 A-C	S2520-E220	4-185	06/10/13	22.218	22.218	1.7	1.8	-6%	
S2520-E220 B-D	S2520-E220	4-185	06/10/13	23.105	23.105	1.9	2.0	-5%	
S2520-W100-2 A-C	S2520-W100	4-186	06/10/13	4.690	24.370	3.0	3.2	-6%	
S2520-W100-2 B-D	S2520-W100	4-186	06/10/13	6.974	22.597	2.4	2.9	-17%	
S2750-E55-2 A-C	S2750-E55	4-187	06/10/13	12.755	29.436	5.1	4.7	9%	
S2750-E55 B-D	S2750-E55	4-187	06/10/13	19.941	19.941	2.4	3.0	-20%	
S2750-E220-2 A-C	S2750-E220	4-188	06/10/13	5.031	26.428	3.6	2.6	38%	
S2750-E220 B-D	S2750-E220	4-188	06/10/13	17.982	17.982	2.0	2.0	0%	
S2750-E410 A-C	S2750-E410	4-189	06/10/13	30.369	30.369	4.6	4.5	2%	
S2750-E410 B-D	S2750-E410	4-189	06/10/13	20.348	20.348	2.6	2.4	8%	
S2750-W93-3 A-C	S2750-W93	4-190	06/10/13	0.929	33.337	2.4	5.7	-58%	
S2750-W93 B-D	S2750-W93	4-190	06/10/13	16.647	16.647	2.2	2.3	-4%	
S3080-E220-2 A-C	S3080-E220	4-191	06/10/13	21.296	24.001	3.3	3.5	-6%	
S3080-E220 B-D	S3080-E220	4-191	06/10/13	17.366	17.366	1.8	1.8	0%	
S3080-W100 A-C	S3080-W100	4-192	06/10/13	30.991	30.991	5.4	4.4	23%	
S3080-W100 B-D	S3080-W100	4-192	06/10/13	18.681	18.681	2.6	2.3	13%	

Table 4-1
Access Drifts Data Analysis (Continued)

Convergence Points (Continued)									
Field Tag	Location	Figure Number	Last Reading 2012-2013		Cumulative Displacement (inches)	Closure Rate 2012 to 2013 (in/year)	Closure Rate 2011 to 2012 (in/year)	Rate Change Percent	Comments
			Date	Inches					
S3310-E55 A-C	S3310-E55	4-193	06/10/13	24.124	24.124	3.2	2.6	23%	
S3310-E55 B-D	S3310-E55	4-193	06/10/13	17.407	17.407	2.1	1.8	17%	
S3310-E220 A-C	S3310-E220	4-194	06/10/13	31.284	31.284	2.1	6.5	-68%	
S3310-E220 B-D	S3310-E220	4-194	06/10/13	19.630	19.630	2.1	1.9	11%	
S3310-W100-3 A-C	S3310-W100	4-195	06/10/13	22.658	28.936	4.1	3.6	14%	
S3310-W100 B-D	S3310-W100	4-195	06/10/13	17.711	17.711	1.8	1.8	0%	
S3650-E55-2 A-C	S3650-E55	4-196	06/10/13	9.706	13.039	2.8	2.6	8%	
S3650-E220-2 A-C	S3650-E220	4-197	06/10/13	9.981	13.338	3.1	2.4	29%	
S3650-W100-2 A-C	S3650-W100	4-198	06/10/13	12.554	18.571	2.8	4.0	-30%	
S3650-W100 B-D	S3650-W100	4-198	06/10/13	12.312	12.312	1.7	1.5	13%	
W30-S120-2 A-C	W30-S120	4-199	06/04/13	7.074	27.068	1.0	1.0	0%	
W30-S250-5 A-C	W30-S250	4-200	06/06/13	8.334	34.567	1.1	1.1	0%	
W30-S250-5 B-D	W30-S250	4-200	06/04/13	18.751	29.705	1.0	0.9	11%	
W30-S400-2 A-C	W30-S400	4-201	06/04/13	6.420	24.248	0.8	0.5	60%	
W30-S500-2 A-C	W30-S500	4-202	06/04/13	7.334	29.844	1.1	1.1	0%	
W30-S500 B-D	W30-S500	4-202	06/04/13	28.279	28.279	1.0	1.0	0%	
W30-S700-5 A-C	W30-S700	4-203	06/04/13	6.616	40.893	1.9	1.7	12%	
W30-S850-5 A-E	W30-S850	4-204	06/04/13	4.113	30.017	2.9	3.9	-26%	
W30-S850-4 B-D	W30-S850	4-205	06/04/13	4.579	20.409	1.4	1.5	-7%	
W30-S850-3 H-F	W30-S850	4-205	06/04/13	6.629	22.197	2.0	2.1	-5%	
W30-S850-4 C-G	W30-S850	4-206	06/04/13	1.609	27.086	1.1	1.5	-27%	
W30-S1000-5 A-C	W30-S1000	4-207	06/04/13	5.177	43.356	1.7	1.8	-6%	
W30-S1150-2 A-C	W30-S1150	4-208	06/04/13	10.507	12.008	3.6	3.0	20%	
W30-S1300-2 A-C	W30-S1300	4-209	06/04/13	6.092	27.330	1.6	1.7	-6%	
W30-S1453-2 A-C	W30-S1453	4-210	06/04/13	7.827	21.894	2.5	2.3	9%	
W30-S1453-3 B-D	W30-S1453	4-210	06/04/13	4.394	18.356	1.3	1.4	-7%	
W30-S1600-3 A-C	W30-S1600	4-211	06/04/13	7.260	26.390	2.0	2.1	-5%	
W30-S1775-3 A-C	W30-S1775	4-212	06/04/13	4.095	21.341	3.1	3.4	-9%	

Table 4-1
Access Drifts Data Analysis (Continued)

Convergence Points (Continued)									
Field Tag	Location	Figure Number	Last Reading 2012-2013		Cumulative Displacement (inches)	Closure Rate 2012 to 2013 (in/year)	Closure Rate 2011 to 2012 (in/year)	Rate Change Percent	Comments
			Date	Inches					
W30-S1775-3 B-D	W30-S1775	4-212	06/04/13	5.339	18.015	1.5	1.6	-6%	
W30-S1950-2 A-C	W30-S1950	4-213	06/06/13	9.226	29.674	2.5	2.7	-7%	
W30-S2067-3 A-C	W30-S2067	4-214	06/04/13	4.826	26.940	3.6	4.3	-16%	
W30-S2067-4 B-D	W30-S2067	4-214	06/04/13	2.222	20.816	1.7	2.1	-19%	
W30-S2275-4 A-C	W30-S2275	4-215	06/03/13	6.795	27.475	4.4	4.3	2%	
W30-S2275-2 B-D	W30-S2275	4-215	06/03/13	6.536	17.716	1.9	2.0	-5%	
W30-S2350-4 A-C	W30-S2350	4-216	06/03/13	9.607	28.916	6.2	6.2	0%	
W30-S2350-2 B-D	W30-S2350	4-216	06/03/13	7.416	19.911	2.3	2.3	0%	
W30-S2425-4 A-C	W30-S2425	4-217	06/03/13	6.479	24.767	4.1	4.3	-5%	
W30-S2425-2 B-D	W30-S2425	4-217	06/03/13	7.359	20.843	2.3	2.4	-4%	
W30-S2520-3 A-C	W30-S2520	4-218	06/03/13	9.155	28.313	3.0	3.1	-3%	
W30-S2685-3 A-C	W30-S2685	4-219	06/03/13	7.154	26.044	2.4	2.3	4%	
W30-S2685-3 B-D	W30-S2685	4-219	06/03/13	6.404	20.674	2.1	2.0	5%	
W30-S2750-3 A-C	W30-S2750	4-220	06/03/13	0.897	19.611	2.5	2.6	-4%	
W30-S2833-4 A-C	W30-S2833	4-221	06/27/13	1.410	24.509	3.3	3.7	-11%	
W30-S2833-2 B-D	W30-S2833	4-221	06/27/13	7.829	19.835	2.8	2.6	8%	
W30-S2916-2 A-C	W30-S2916	4-222	06/27/13	1.628	42.677	3.8	6.2	-39%	
W30-S2916-2 B-D	W30-S2916	4-222	06/27/13	6.722	17.106	2.4	2.2	9%	
W30-S2998-2 A-C	W30-S2998	4-223	06/27/13	1.438	25.882	3.4	5.1	-33%	
W30-S2998-2 B-D	W30-S2998	4-223	06/27/13	5.861	16.578	2.1	2.0	5%	
W30-S3080 A-C	W30-S3080	4-224	06/03/13	26.203	26.203	2.1	2.1	0%	
W30-S3195 A-C	W30-S3195	4-225	06/03/13	22.513	22.513	2.8	3.2	-13%	
W30-S3195 B-D	W30-S3195	4-225	06/03/13	16.002	16.002	1.7	1.6	6%	
W30-S3310 A-C	W30-S3310	4-226	06/03/13	18.839	18.839	1.7	1.8	-6%	
W30-S3395 A-C	W30-S3395	4-227	07/09/12	12.722	12.722	N/A	1.8	N/A	These instruments were read once in 2012-2013—blocked.
W30-S3395 B-D	W30-S3395	4-227	07/09/12	10.603	10.603	N/A	1.4	N/A	
W30-S3650-2 A-C	W30-S3650	4-228	06/10/13	8.956	14.608	2.2	2.1	5%	

Table 4-1
Access Drifts Data Analysis (Continued)

Convergence Points (Continued)									
Field Tag	Location	Figure Number	Last Reading 2012-2013		Cumulative Displacement (Inches)	Closure Rate 2012 to 2013 (in/year)	Closure Rate 2011 to 2012 (in/year)	Rate Change Percent	Comments
			Date	Inches					
W170-N150-3 A-C	W170-N150	4-229	05/07/13	3.251	11.603	0.6	0.6	0%	
W170-S5 A-C	W170-S5	4-230	05/07/13	15.932	15.932	0.6	0.5	20%	
W170-S5-2 B-D	W170-S5	4-230	05/07/13	10.562	18.328	0.7	0.7	0%	
W170-S90-3 A-C	W170-S90	4-231	05/07/13	10.124	17.326	0.8	0.9	-11%	
W170-S232-2 A-C	W170-S232	4-232	05/07/13	7.477	13.066	0.6	0.6	0%	
W170-S232-2 B-D	W170-S232	4-232	05/07/13	10.781	13.423	0.6	0.6	0%	
W170-S400 A-C	W170-S400	4-233	05/07/13	15.943	15.943	0.7	0.7	0%	
W170-S560-4 A-C	W170-S560	4-234	05/07/13	3.622	14.441	0.7	0.8	-13%	
W170-S560-3 B-D	W170-S560	4-234	05/07/13	2.692	15.520	0.7	0.7	0%	
W170-S700-2 A-C	W170-S700	4-235	05/07/13	4.918	24.711	1.1	1.3	-15%	
W170-S850-7 A-E	W170-S850	4-236	05/07/13	3.634	20.623	0.8	0.7	14%	
W170-S850-6 B-D	W170-S850	4-237	05/07/13	3.178	15.918	0.7	0.6	17%	
W170-S850-3 C-G	W170-S850	4-238	05/07/13	13.062	23.875	0.9	0.9	0%	
W170-S850-7 H-F	W170-S850	4-239	05/07/13	2.634	14.255	0.6	0.5	20%	
W170-S1000-3 A-C	W170-S1000	4-240	05/07/13	5.280	28.193	1.1	1.1	0%	
W170-S1150-4 A-E	W170-S1150	4-241	05/07/13	4.257	24.686	0.9	0.8	13%	
W170-S1150-4 B-D	W170-S1150	4-241	05/07/13	3.496	17.693	0.9	0.7	29%	
W170-S1150-2 H-F	W170-S1150	4-241	05/07/13	3.459	16.865	0.7	0.7	0%	
W170-S1150-2 C-G	W170-S1150	4-242	05/07/13	14.801	26.378	1.1	1.1	0%	
W170-S1300-4 A-C	W170-S1300	4-243	05/07/13	9.485	30.443	1.7	1.8	-6%	
W170-S1445-4 A-C	W170-S1445	4-244	05/07/13	7.778	19.070	1.6	1.7	-6%	
W170-S1445-2 B-D	W170-S1445	4-244	05/07/13	14.102	16.760	1.1	1.1	0%	
W170-S1600-4 A-C	W170-S1600	4-245	05/07/13	6.818	21.583	1.8	1.7	6%	
W170-S1779-3 A-C	W170-S1779	4-246	05/07/13	7.667	22.638	1.6	1.6	0%	
W170-S1779-2 B-D	W170-S1779	4-246	05/07/13	17.134	20.269	1.4	1.4	0%	
W170-S1950-3 A-C	W170-S1950	4-247	05/07/13	6.270	19.451	1.4	1.5	-7%	
W170-S2060-3 A-C	W170-S2060	4-248	05/07/13	1.954	20.198	1.5	1.5	0%	
W170-S2060-2 B-D	W170-S2060	4-248	05/07/13	19.002	22.326	1.8	2.0	-10%	

Table 4-1
Access Drifts Data Analysis (Continued)

Convergence Points (Continued)									
Field Tag	Location	Figure Number	Last Reading 2012-2013		Cumulative Displacement (inches)	Closure Rate 2012 to 2013 (in/year)	Closure Rate 2011 to 2012 (in/year)	Rate Change Percent	Comments
			Date	Inches					
W170-S2180-3 A-C	W170-S2180	4-249	06/03/13	2.702	26.266	2.0	1.7	18%	
W170-S2275 A-C	W170-S2275	4-250	06/03/13	17.133	17.133	1.7	1.9	-11%	
W170-S2275 B-D	W170-S2275	4-250	06/03/13	19.964	19.964	2.4	2.5	-4%	
W170-S2350 A-C	W170-S2350	4-251	06/03/13	22.614	22.614	2.2	2.6	-15%	
W170-S2350 B-D	W170-S2350	4-251	06/03/13	19.710	19.710	2.1	2.4	-13%	
W170-S2425 A-C	W170-S2425	4-252	06/03/13	19.773	19.773	1.8	2.0	-10%	
W170-S2425 B-D	W170-S2425	4-252	06/03/13	22.079	22.079	2.4	2.6	-8%	
W170-S2520-2 A-C	W170-S2520	4-253	06/03/13	5.480	26.075	3.4	3.8	-11%	
W170-S2685-2 A-C	W170-S2685	4-254	06/05/13	24.055	25.901	1.8	2.0	-10%	
W170-S2685-2 B-D	W170-S2685	4-254	06/05/13	20.439	22.302	2.2	2.4	-8%	
W170-S2833 A-C	W170-S2833	4-255	04/11/13	35.147	35.147	5.8	5.5	5%	
W170-S2833 B-D	W170-S2833	4-255	06/03/13	20.594	20.594	2.9	3.0	-3%	
W170-S2916 A-C	W170-S2916	4-256	06/03/13	30.532	30.532	2.9	3.5	-17%	
W170-S2916 B-D	W170-S2916	4-256	06/03/13	18.941	18.941	2.3	2.4	-4%	
W170-S2998 A-C	W170-S2998	4-257	04/08/13	42.015	42.015	4.9	6.6	-26%	
W170-S2998-2 B-D	W170-S2998	4-257	06/03/13	8.835	21.528	3.3	3.1	6%	
W170-S3080 A-C	W170-S3080	4-258	06/03/13	26.886	26.886	3.2	3.3	-3%	
W170-S3195 A-C	W170-S3195	4-259	06/03/13	25.515	25.515	3.0	3.0	0%	
W170-S3195 B-D	W170-S3195	4-259	06/03/13	17.462	17.462	1.9	1.9	0%	
W170-S3310 A-C	W170-S3310	4-260	06/03/13	21.849	21.849	2.0	1.9	5%	
W170-S3395 A-C	W170-S3395	4-261	06/03/13	24.754	24.754	4.8	3.6	33%	
W170-S3395 B-D	W170-S3395	4-261	06/03/13	14.179	14.179	2.1	1.9	11%	
W170-S3480 A-C	W170-S3480	4-262	06/03/13	27.257	27.257	5.6	4.0	40%	
W170-S3480 B-D	W170-S3480	4-262	06/03/13	17.951	17.951	2.4	2.3	4%	
W170-S3565 A-C	W170-S3565	4-263	06/03/13	15.590	15.590	2.2	2.2	0%	
W170-S3565 B-D	W170-S3565	4-263	06/03/13	12.586	12.586	1.6	1.5	7%	
W170-S3650-2 A-C	W170-S3650	4-264	06/10/13	8.358	16.003	1.9	1.8	6%	

Table 4-1
Access Drifts Data Analysis (Continued)

Joint Meters								
Field Tag	Location	Figure Number	Date	Cumulative Displacement (inches)	Closure Rate 2012 to 2013 (in/year)	Closure Rate 2011 to 2012 (in/year)	Rate Change Percent ¹	Comments
51X-CG-02706	S1950-E300	4-265	06/26/13	2.122	0.2	0.2	0%	
51X-CG-02707	S1950-E300	4-265	06/26/13	2.085	0.1	0.1	0%	
51X-CG-02876-2	E140-S1505	4-266	06/26/13	0.050	-0.1	0.0	N/A	Data plot indicates the fracture is closing.
51X-CG-02883-2	E140-S1529	4-267	11/14/12	0.676	0.2	0.3	-33%	
51X-CG-02885-2	E140-S1545	4-268	06/26/13	0.746	0.0	0.1	-100%	
51X-CG-02875-2	E140-S1795	4-269	06/27/13	0.489	0.1	0.2	-50%	
51X-CG-02713	E140-S2964	4-270	06/26/13	-0.419	-0.3	-0.4	-25%	

Table 4-1
Access Drifts Data Analysis (Continued)

Rockbolt Load Cells						
Field Tag	Location	Figure Number	Date of Initial Reading	Date of Last Reading	Load (klps)	Comments
5 ¹ X-WG-00325	E140-N1266	4-271	09/23/10	06/11/13	43.6	
51X-WG-00326	E140-N1266	4-271	09/23/10	06/11/13	43.5	
51X-WG-00327	E140-N1266	4-271	09/23/10	06/11/13	40.9	
51X-WG-00328	E140-N1266	4-271	09/23/10	06/11/13	40.9	
51X-WG-00329	E140-N1266	4-271	09/23/10	06/11/13	44.9	
51X-WG-00330	E140-N1266	4-272	09/23/10	06/11/13	35.2	
51X-WG-00331	E140-N1266	4-272	09/23/10	06/11/13	40.6	
51X-WG-00332	E140-N1266	4-272	09/23/10	06/11/13	40.5	
51X-WG-00333	E140-N1266	4-272	09/23/10	06/11/13	37.2	
51X-WG-00214	E140-S910	4-273	06/26/97	06/20/13	0.0	The rock bolt has failed.
51X-WG-00215-2	E140-S910	4-273	10/21/09	06/20/13	0.0	The rock bolt has failed.
51X-WG-00216	E140-S910	4-273	06/26/97	06/20/13	32.1	
51X-WG-00217	E140-S910	4-273	06/26/97	06/20/13	1.0	
51X-WG-00218	E140-S775	4-274	06/26/97	06/20/13	0.6	The rock bolt has failed.
51X-WG-00219	E140-S975	4-274	06/26/97	06/20/13	40.3	
51X-WG-00220	E140-S1023	4-274	10/23/96	06/20/13	18.4	
51X-WG-00293	E140-S1550	4-275	03/17/04	06/26/13	56.3	
51X-WG-00294	E140-S1775	4-276	03/17/04	05/22/13	61.8	
51X-WG-00296-2	E140-S2916	4-277	03/18/10	06/26/13	41.2	
51X-WG-00295-2	E140-S2916	4-277	03/18/10	06/26/13	38.7	
51X-WG-00221	S1300-E120	4-278	10/23/96	01/21/13	2.5	
51X-WG-00222	S1300-E160	4-279	10/23/96	01/21/13	43.5	
51X-WG-00223	S1600-E150	4-280	02/18/96	06/28/13	8.1	

N/A – Insufficient data available to perform the calculation. This is usually due to the inability to read the instruments because of activities such as: the temporary removal of an instrument due to floor, rib or back trimming; locations blocked by equipment or waste disposal; installation timing, etc.

²During a period of inaccessibility, an additional 20.753 inches of displacement was recorded (not represented in the cumulative) by a remotely read convergence meter from June 1996 until May 2002. Remote readings were not taken at E300-N1341.

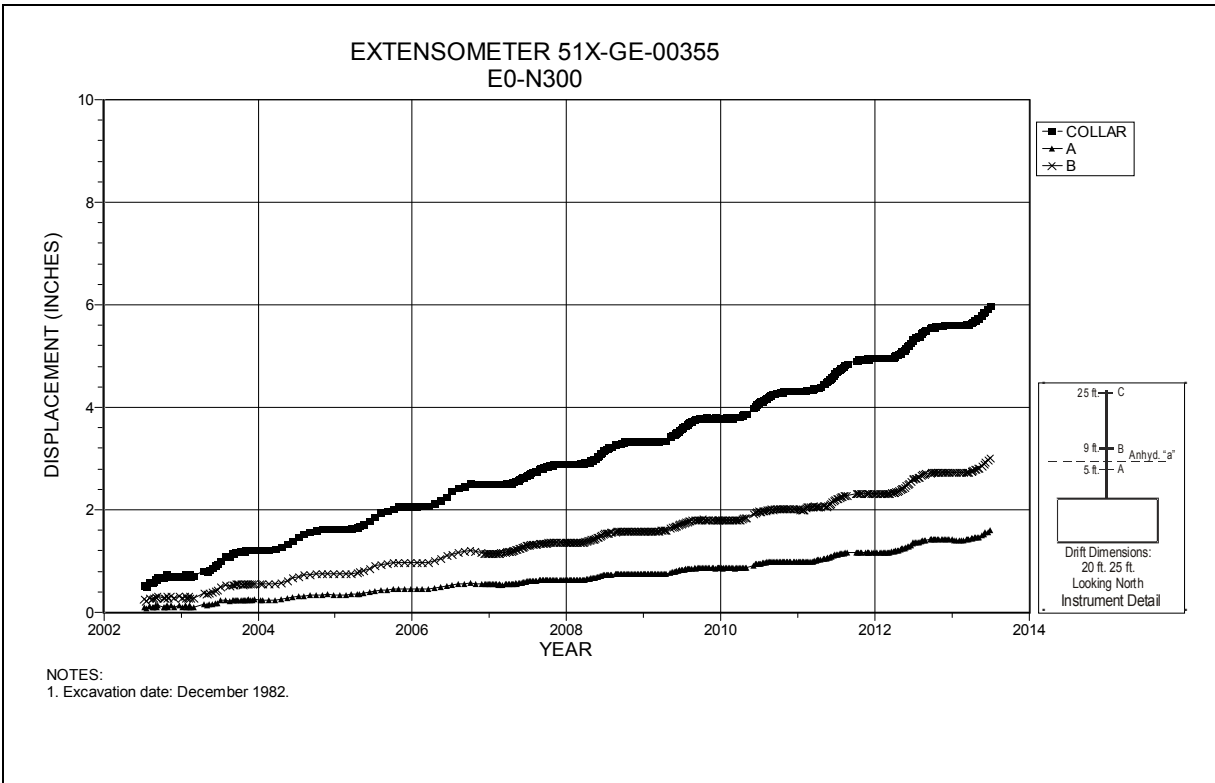

Figure 4-1 Extensometer 51X-GE-00355
E0 N300 – Roof

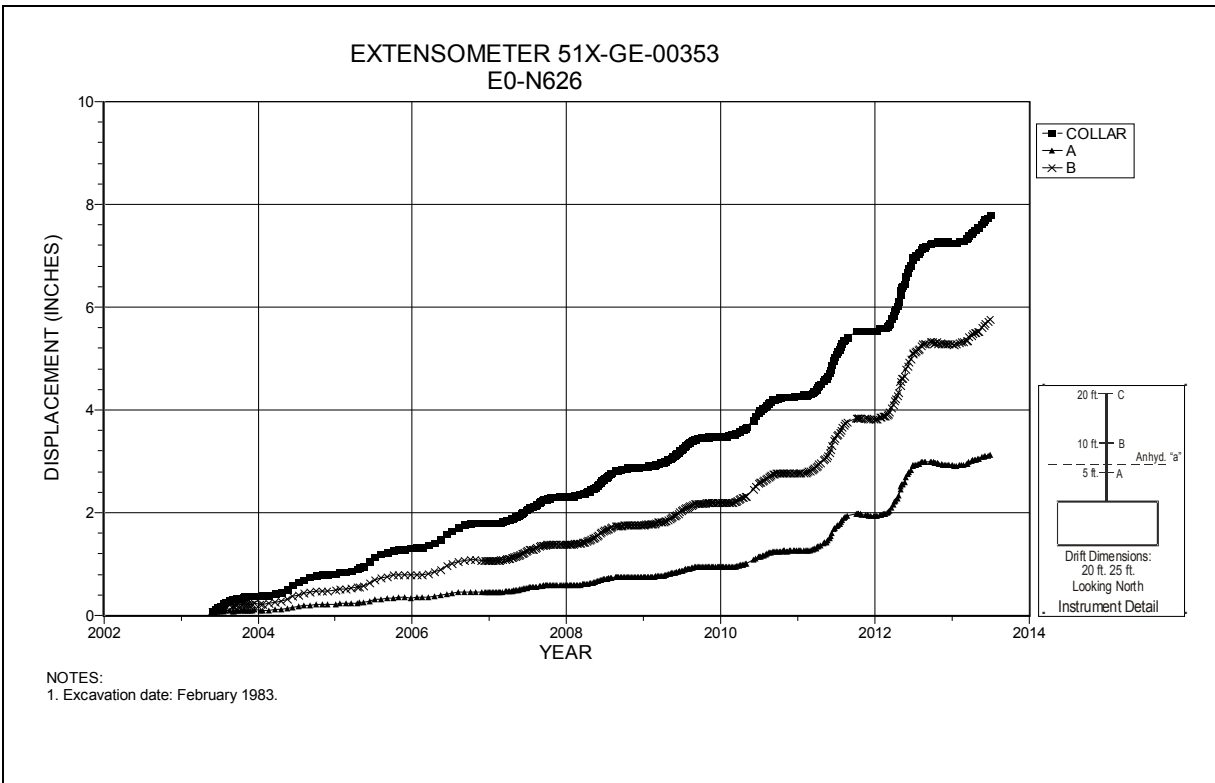

Figure 4-2 Extensometer 51X-GE-00353
E0 N626 – Roof

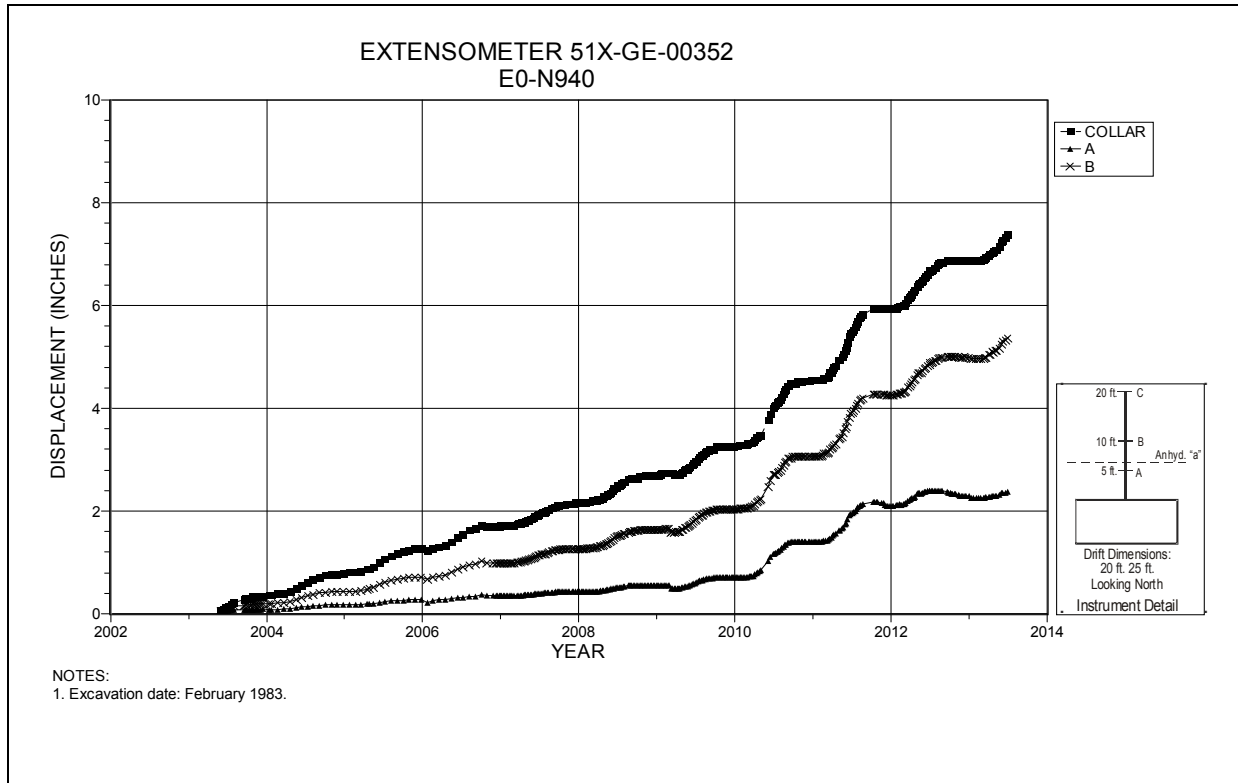

Figure 4-3 Extensometer 51X-GE-00352
E0 N940 – Roof

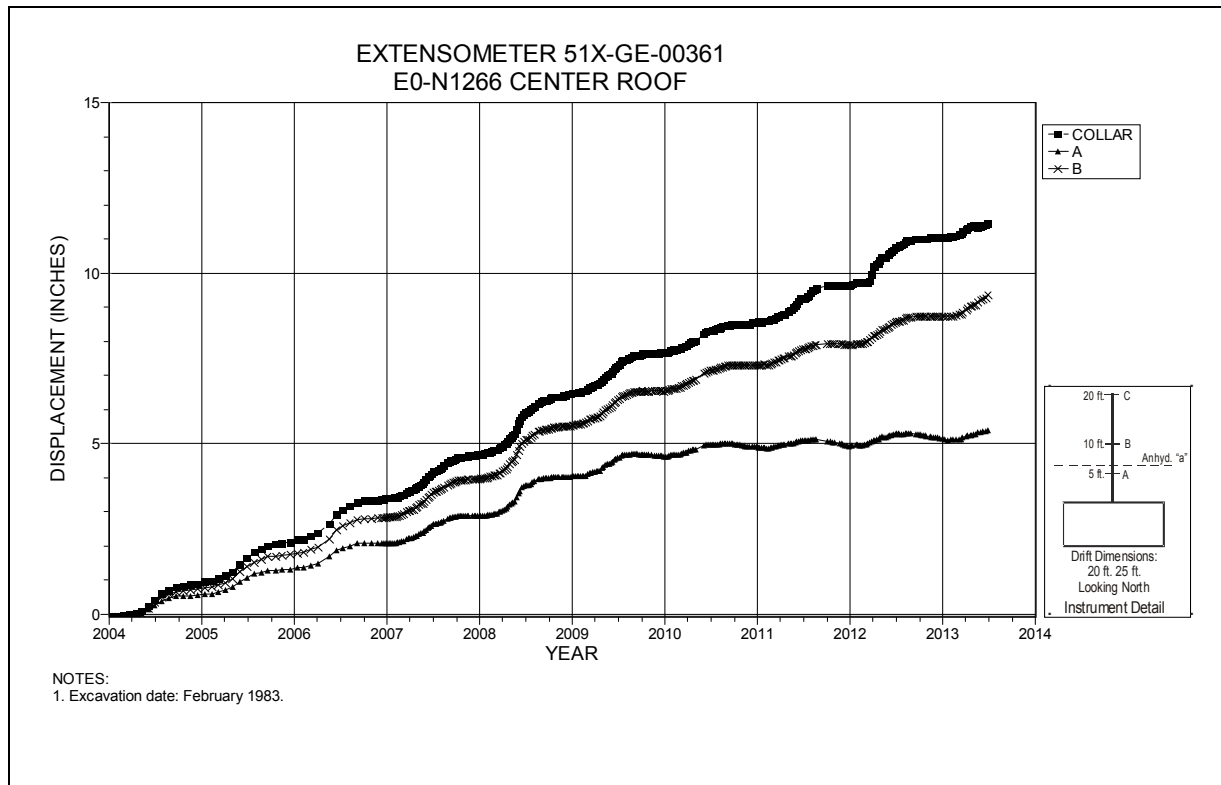

Figure 4-4 Extensometer 51X-GE-00361
E0-N1266 – Roof

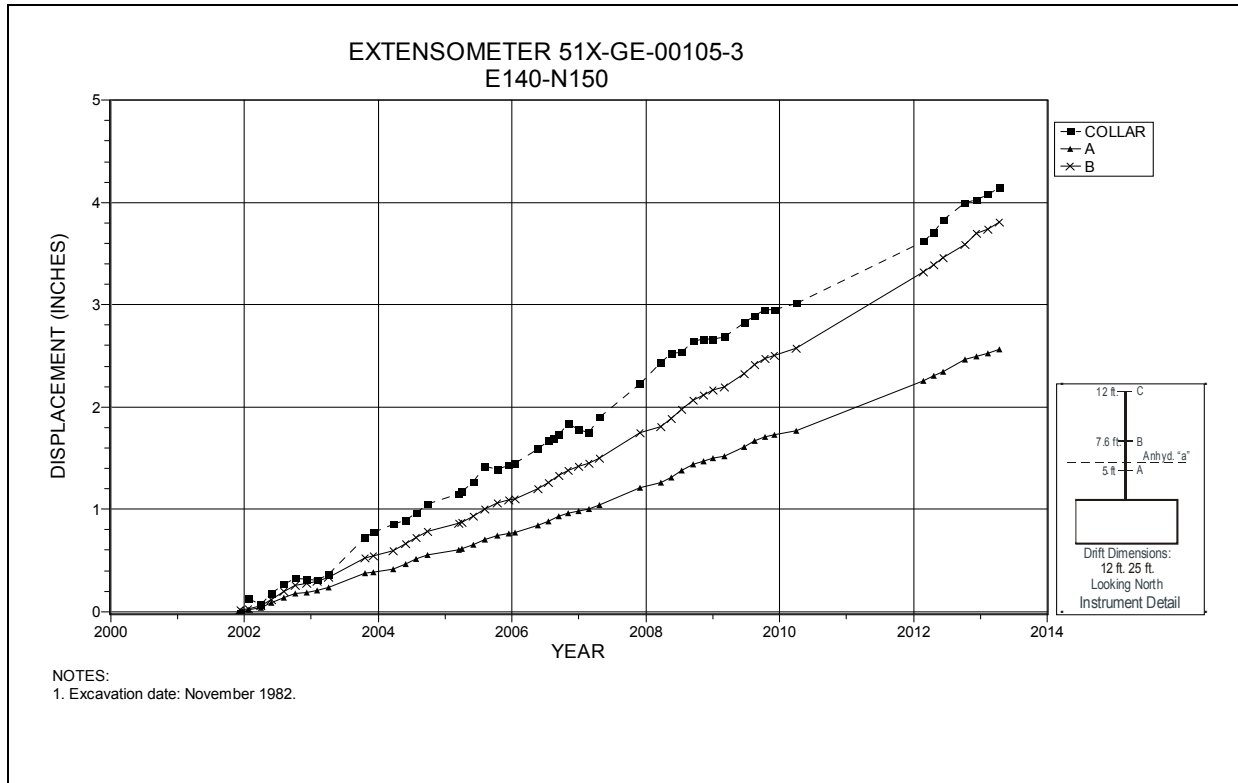

Figure 4-5 Extensometer 51X-GE-00105-3
E140 N150 – Roof

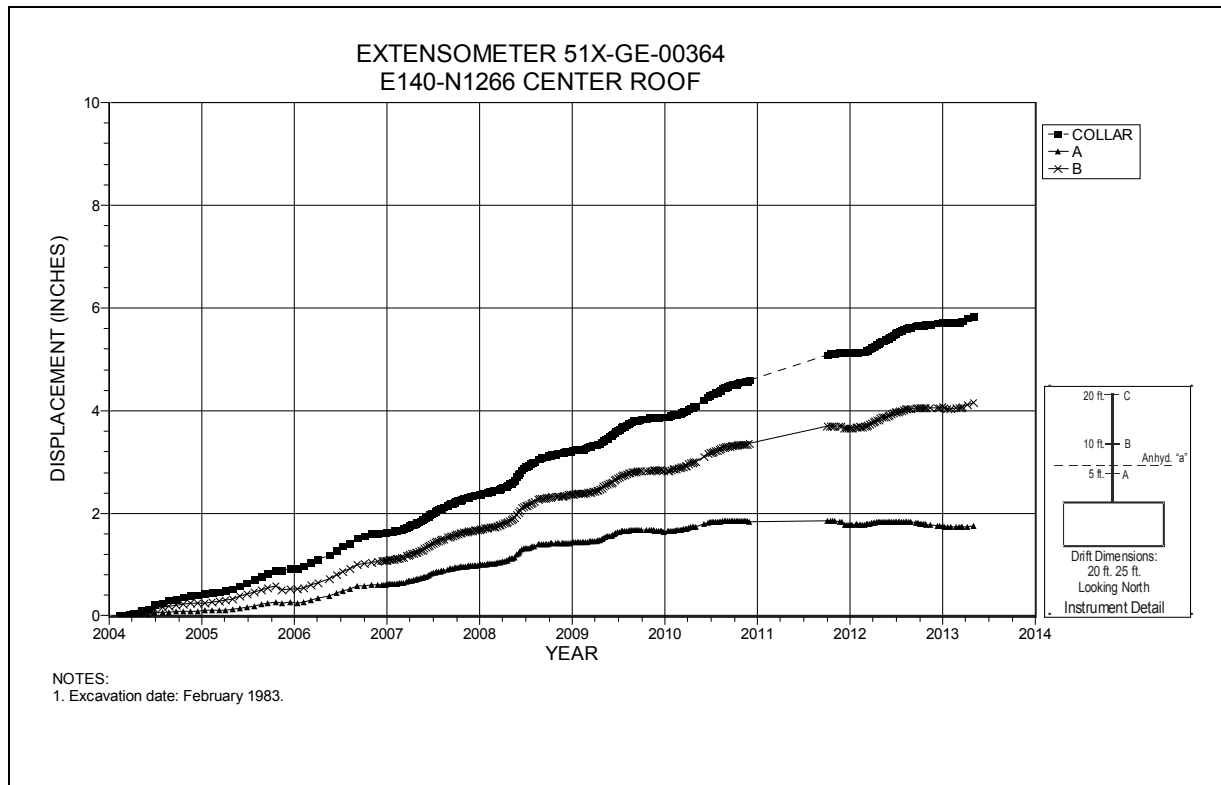

Figure 4-6 Extensometer 51X-GE-00364
E140 N1266 – Roof

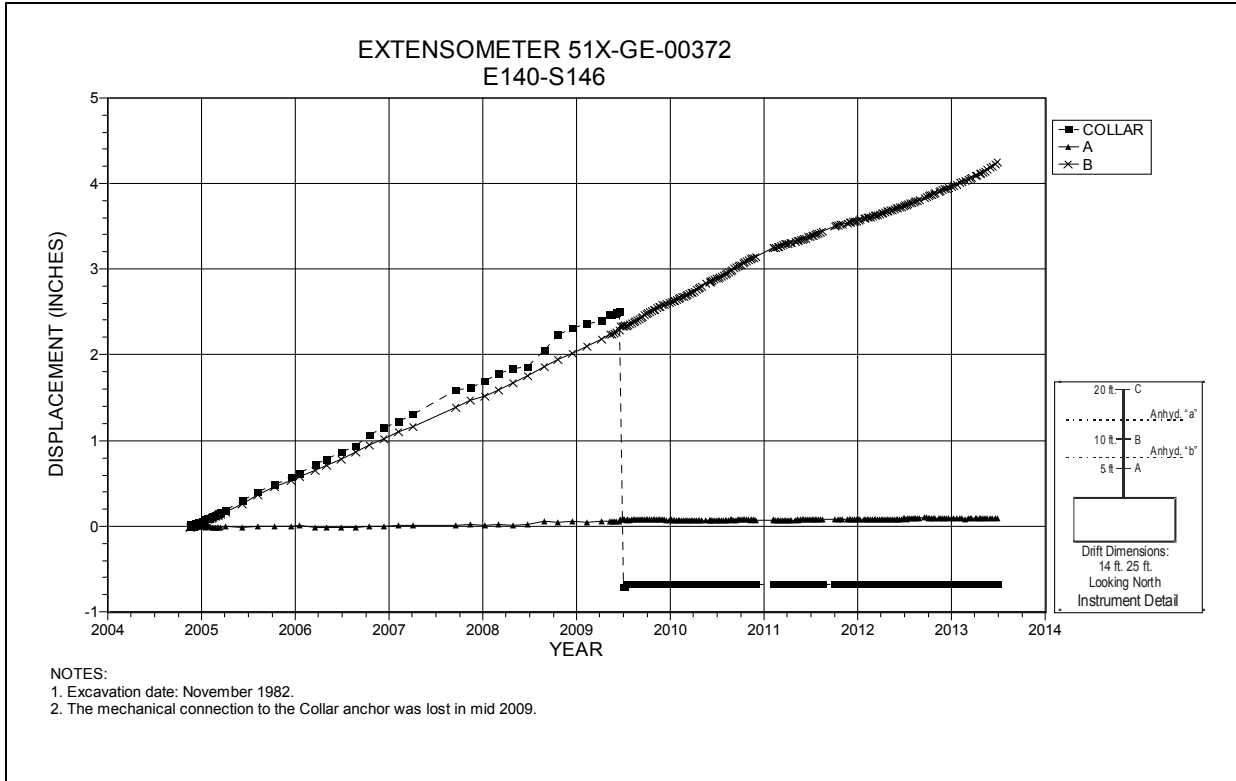

Figure 4-7 Extensometer 51X-GE-00372
E140 S146 – Roof

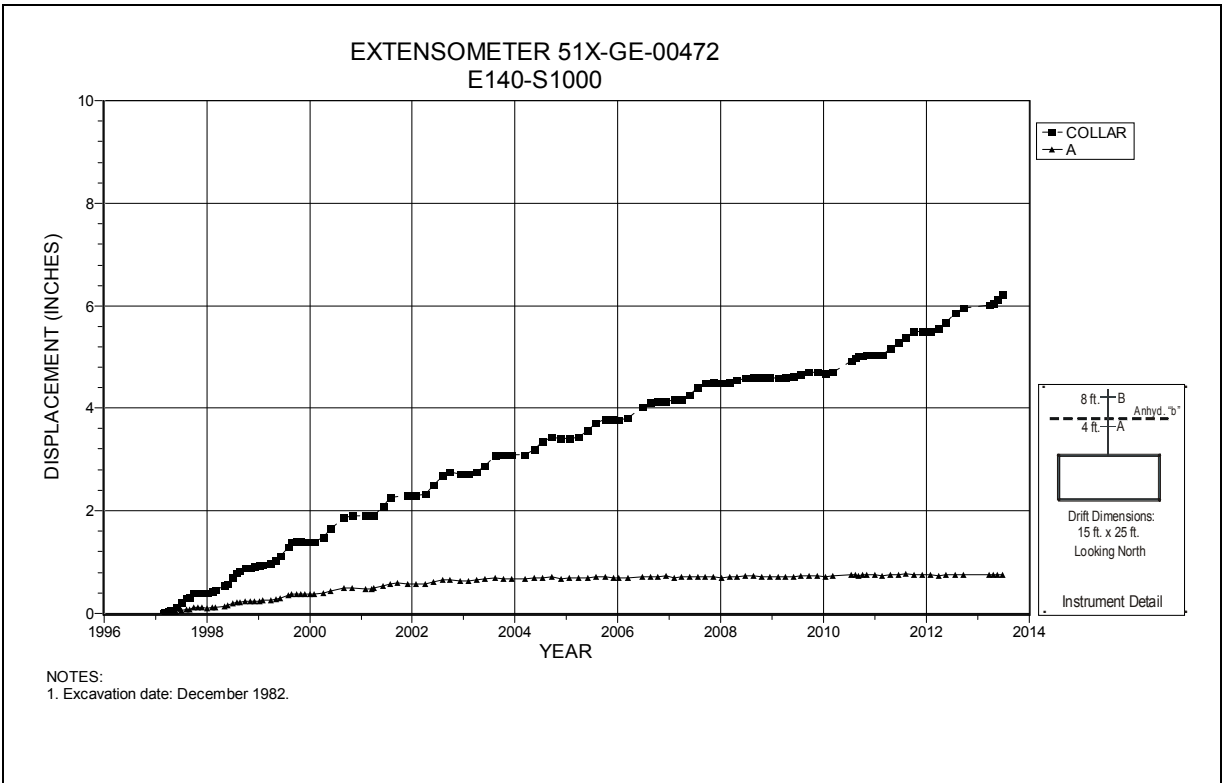

Figure 4-8 Extensometer 51X-GE-00472
E140 S1000 – Roof

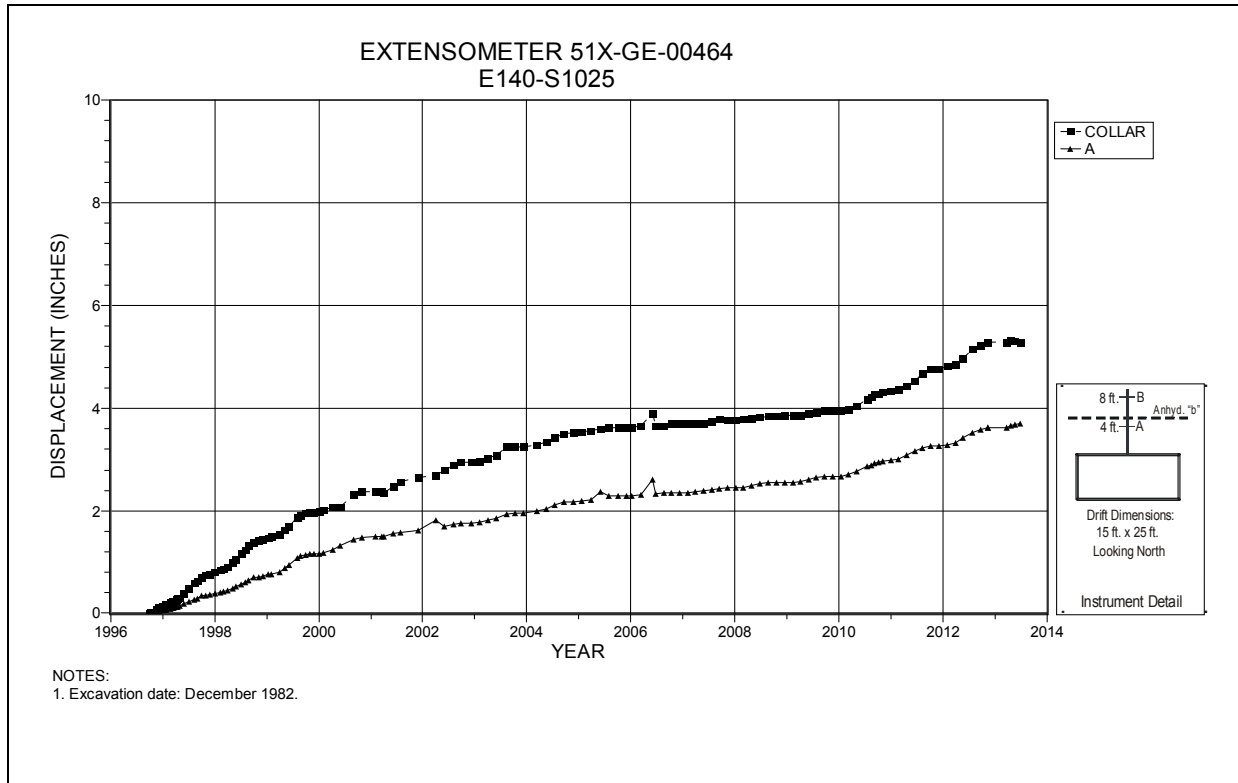

Figure 4-9 Extensometer 51X-GE-00464
E140 S1025 – Roof

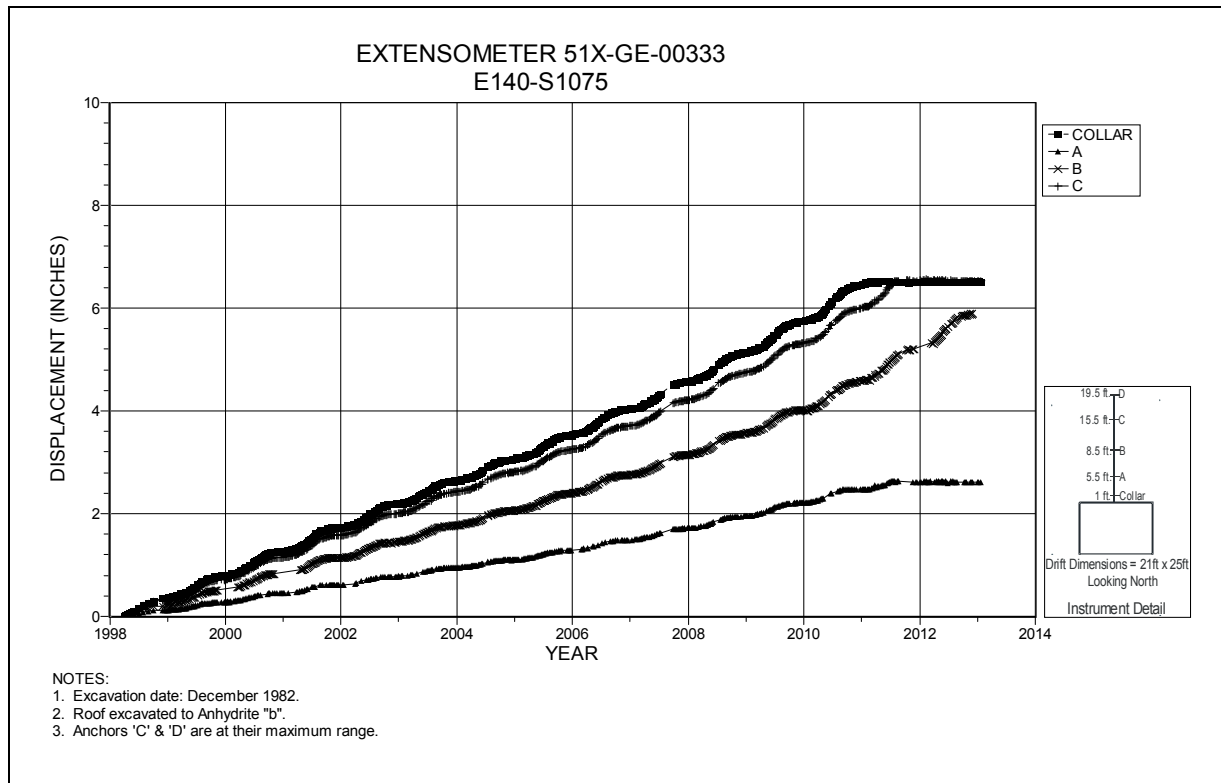

Figure 4-10 Extensometer 51X-GE-00333
E140 S1075 – Roof

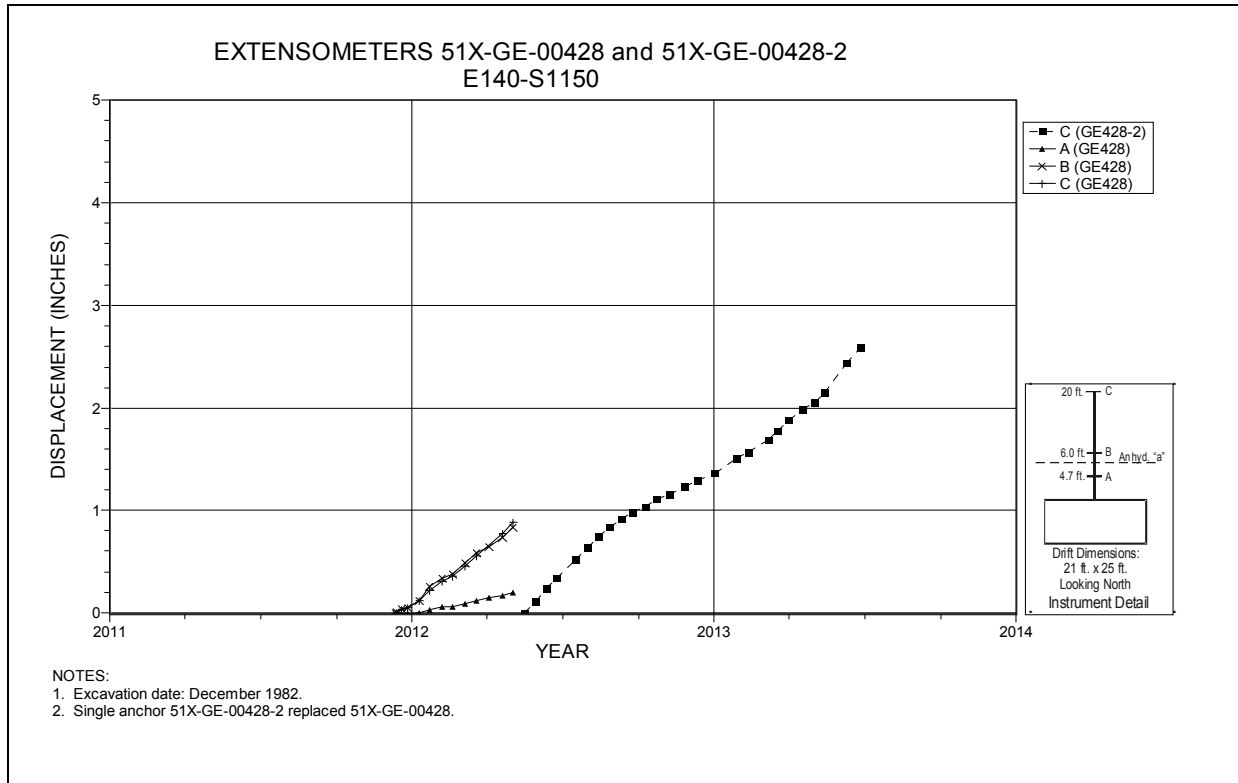

Figure 4-11 Extensometers 51X-GE-00428 and 51X-GE-00428-2
E140 S1150 – Roof

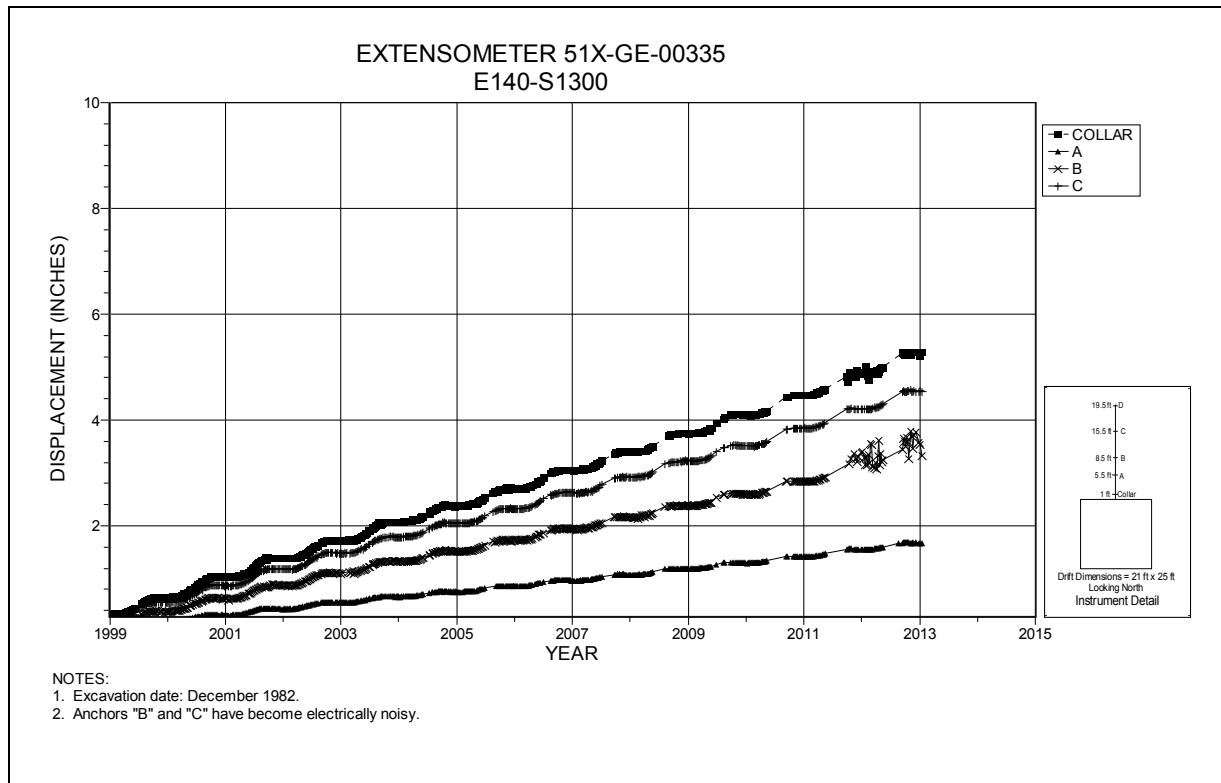

Figure 4-12 Extensometer 51X-GE-00335
E140 S1300 – Roof

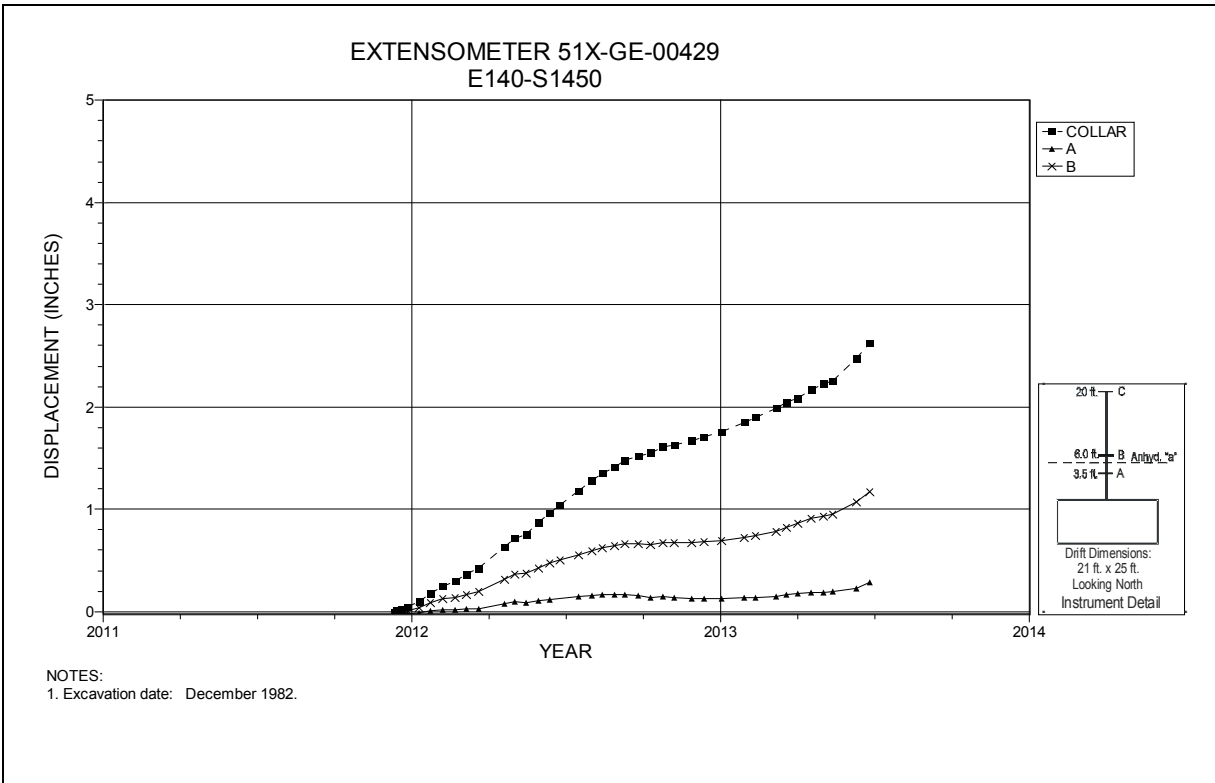

Figure 4-13 Extensometer 51X-GE-00429
E140 S1450 – Roof

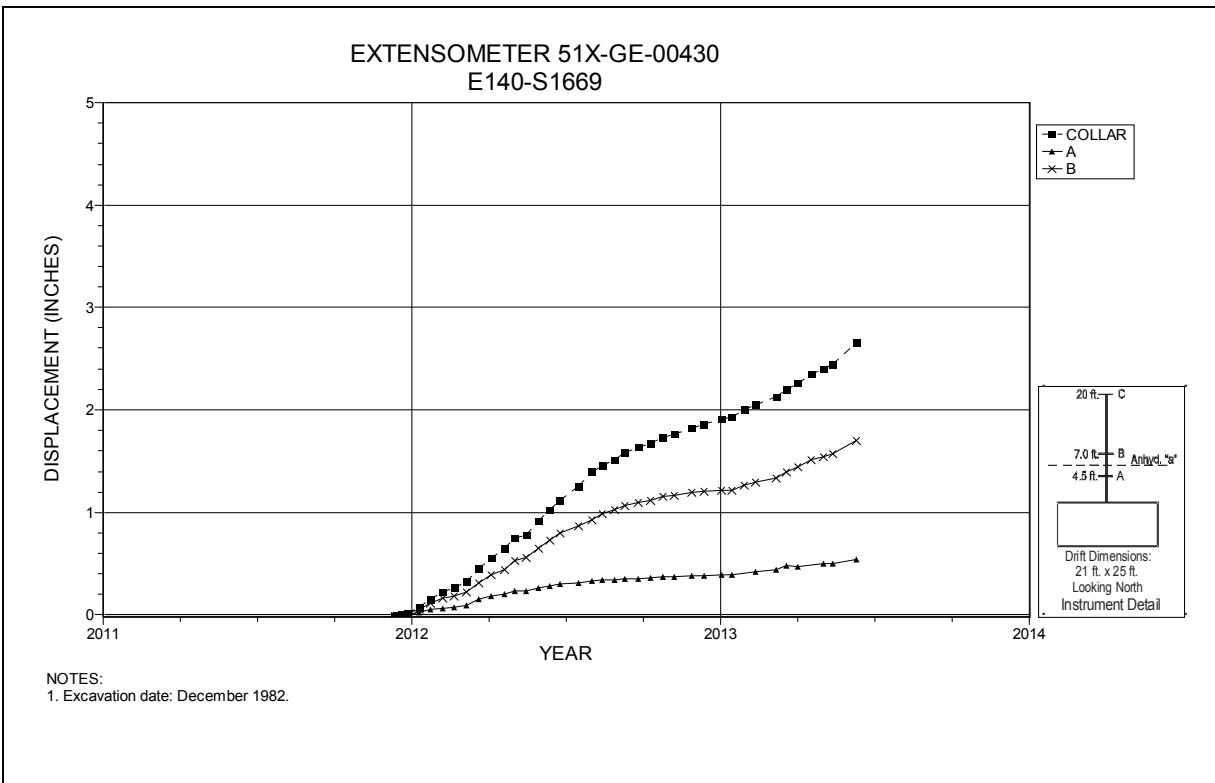

Figure 4-14 Extensometer 51X-GE-00430
E140 S1669 – Roof

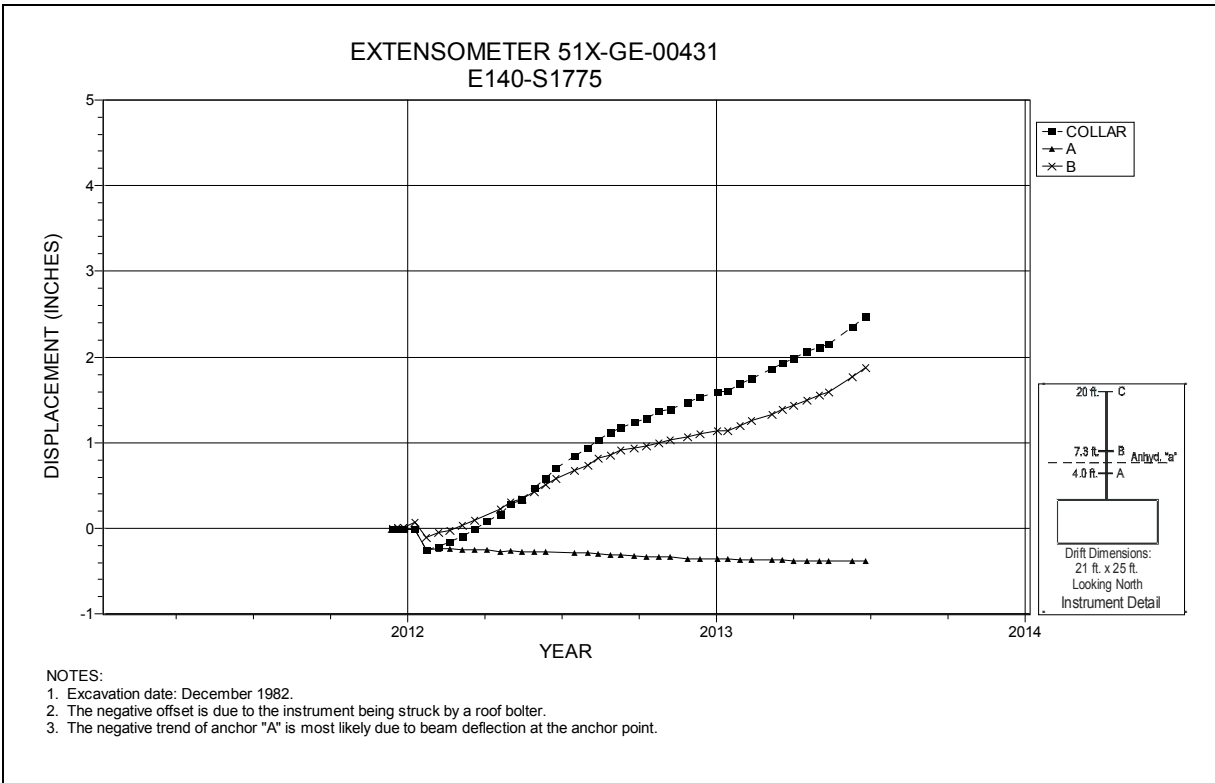

Figure 4-15 Extensometer 51X-GE-00431
E140 S1775 – Roof

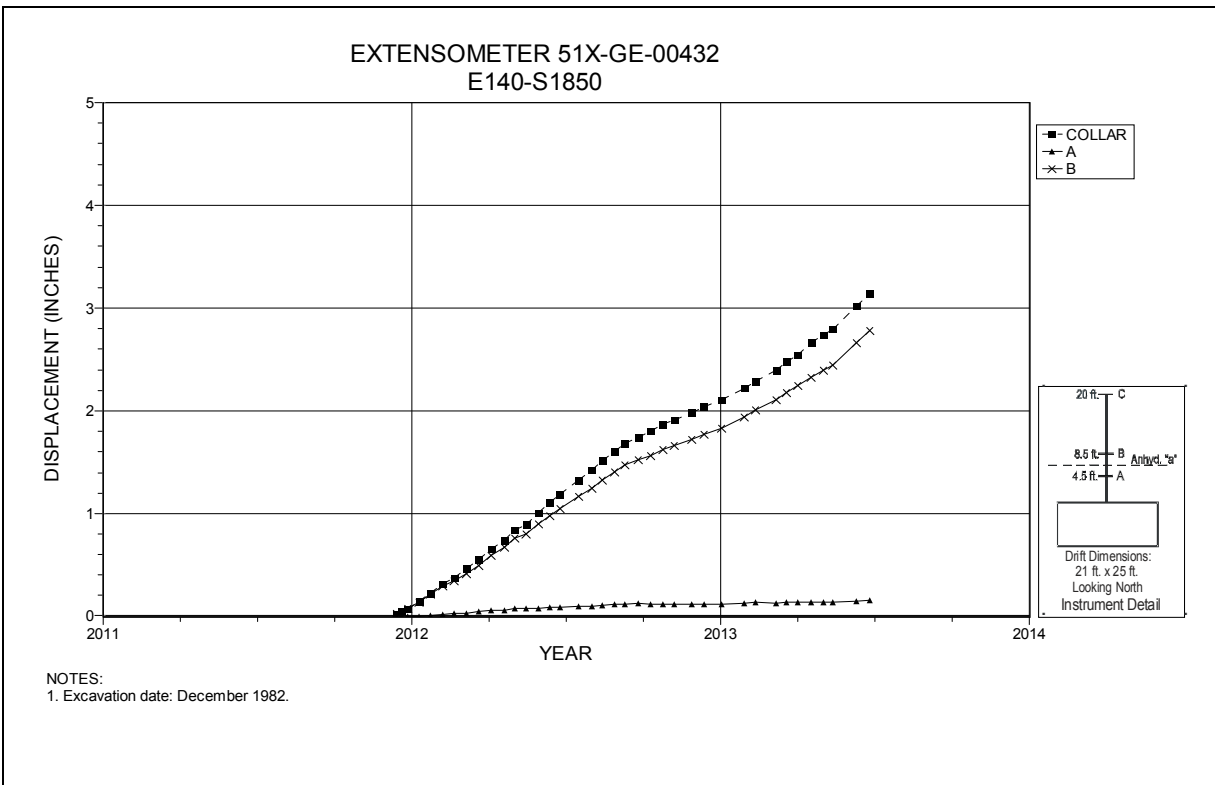
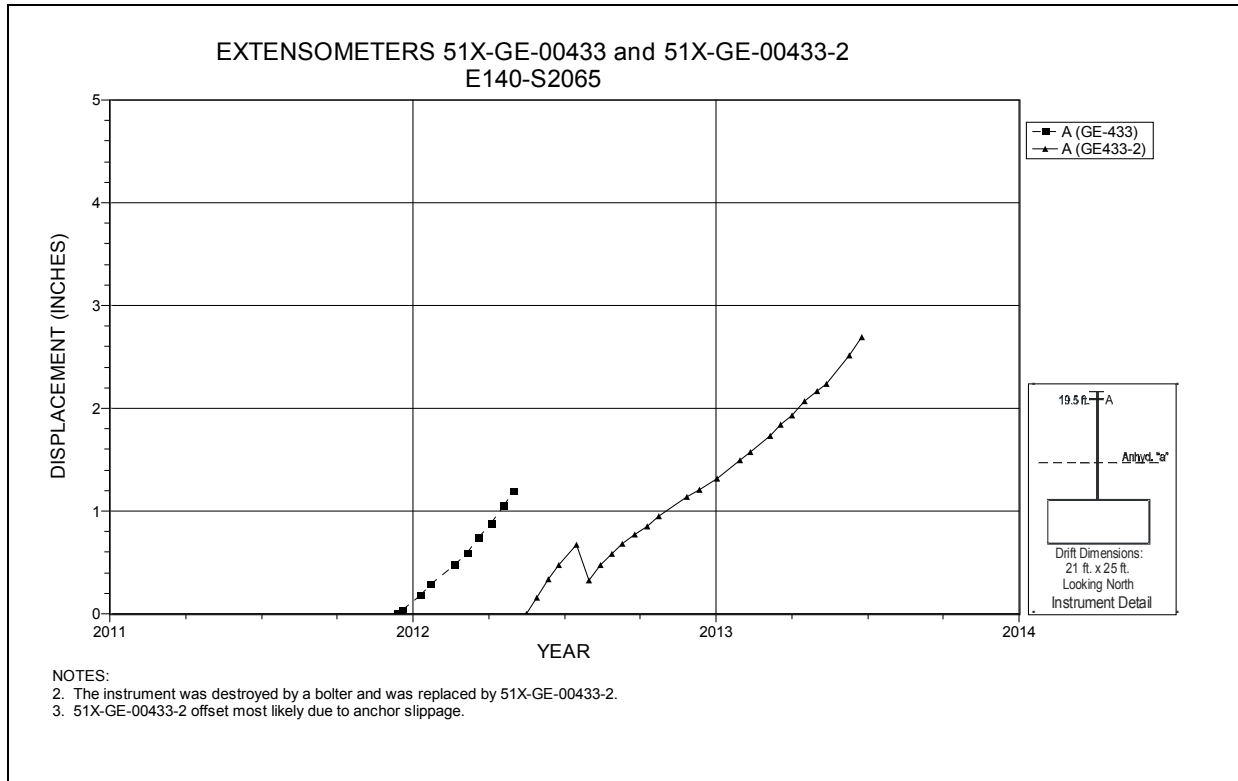
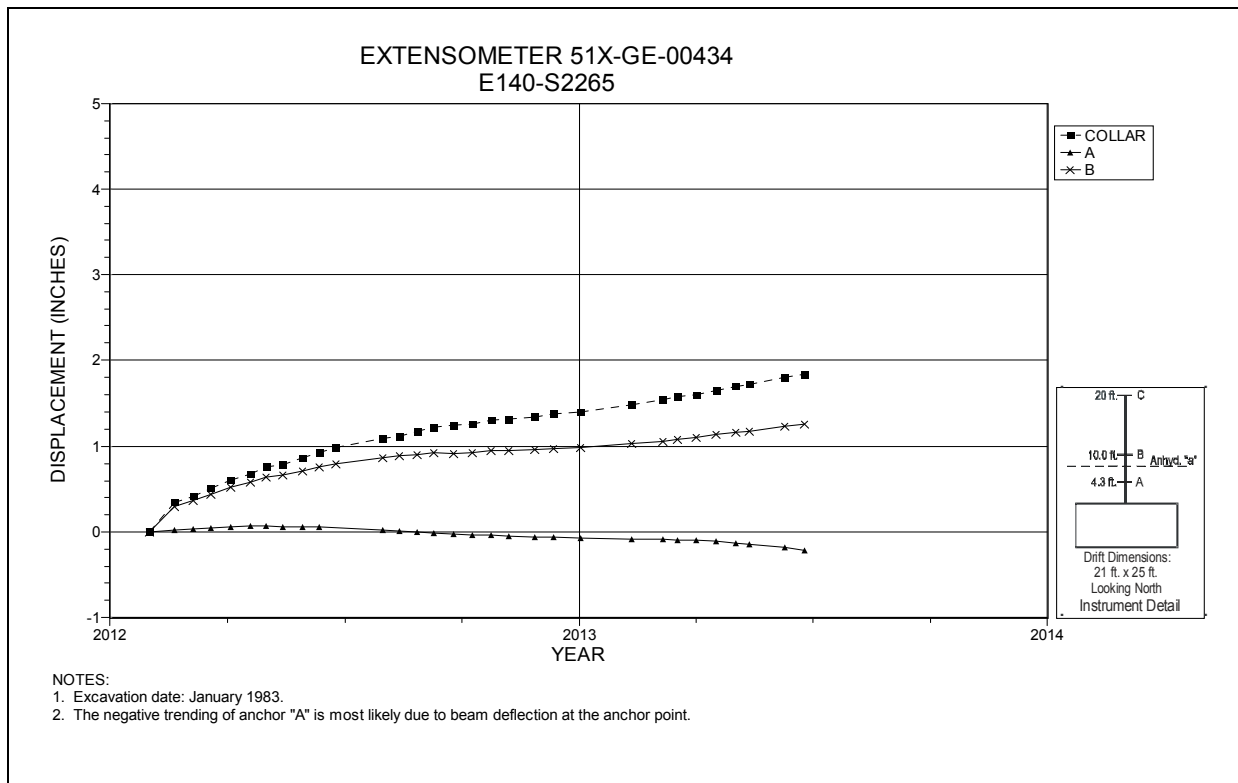

Figure 4-16 Extensometer 51X-GE-00432
E140 S1850 – Roof



**Figure 4-17 Extensometers 51X-GE-00433 and 51X-GE-00433-2
E140 S2065 – Roof**



**Figure 4-18 Extensometer 51X-GE-00434
E140 S2265 – Roof**

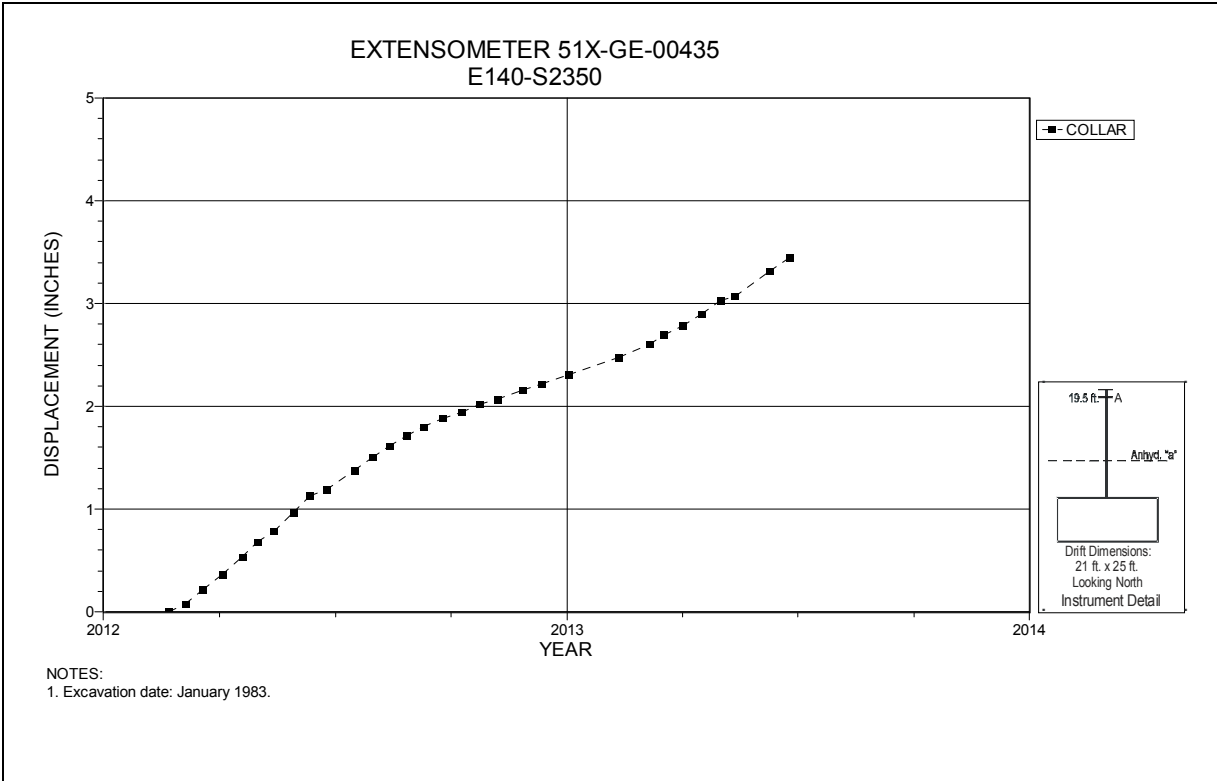

Figure 4-19 Extensometer 41X-GE-00435
E140 S2350 – Roof

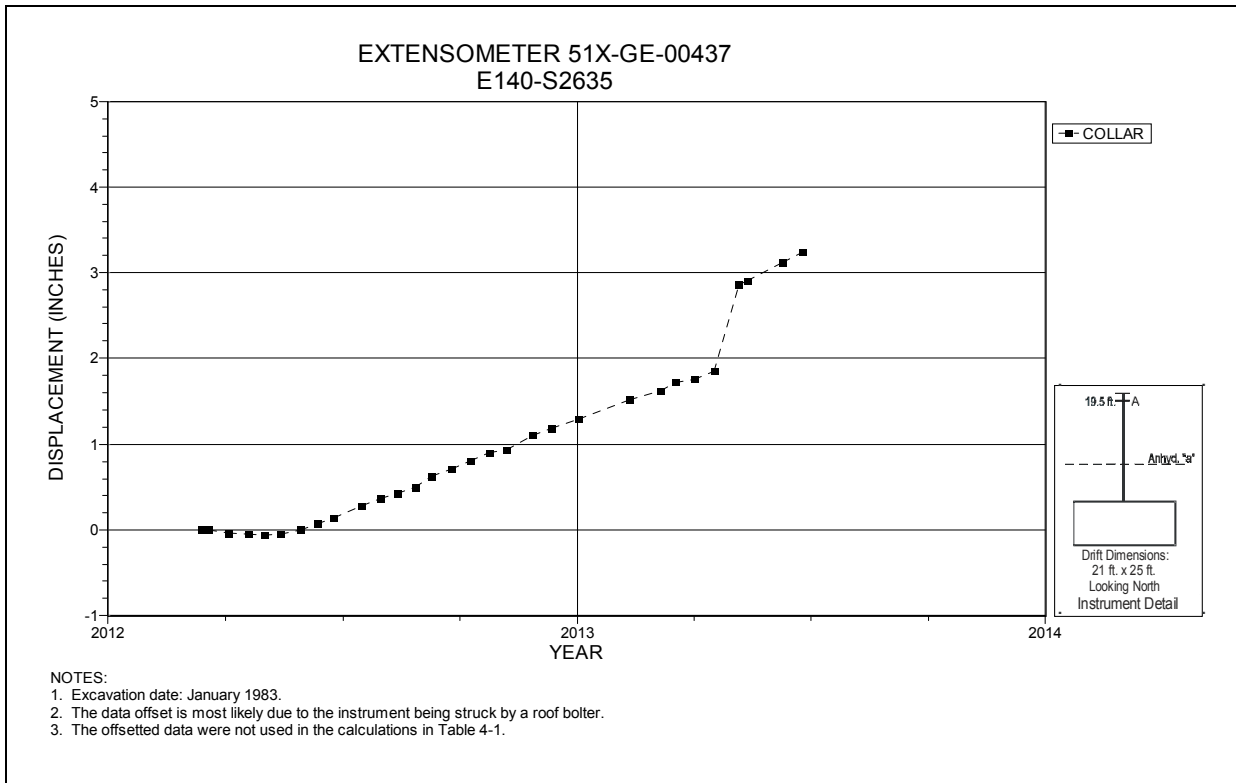

Figure 4-20 Extensometer 41X-GE-00437
E140 S2635 – Roof

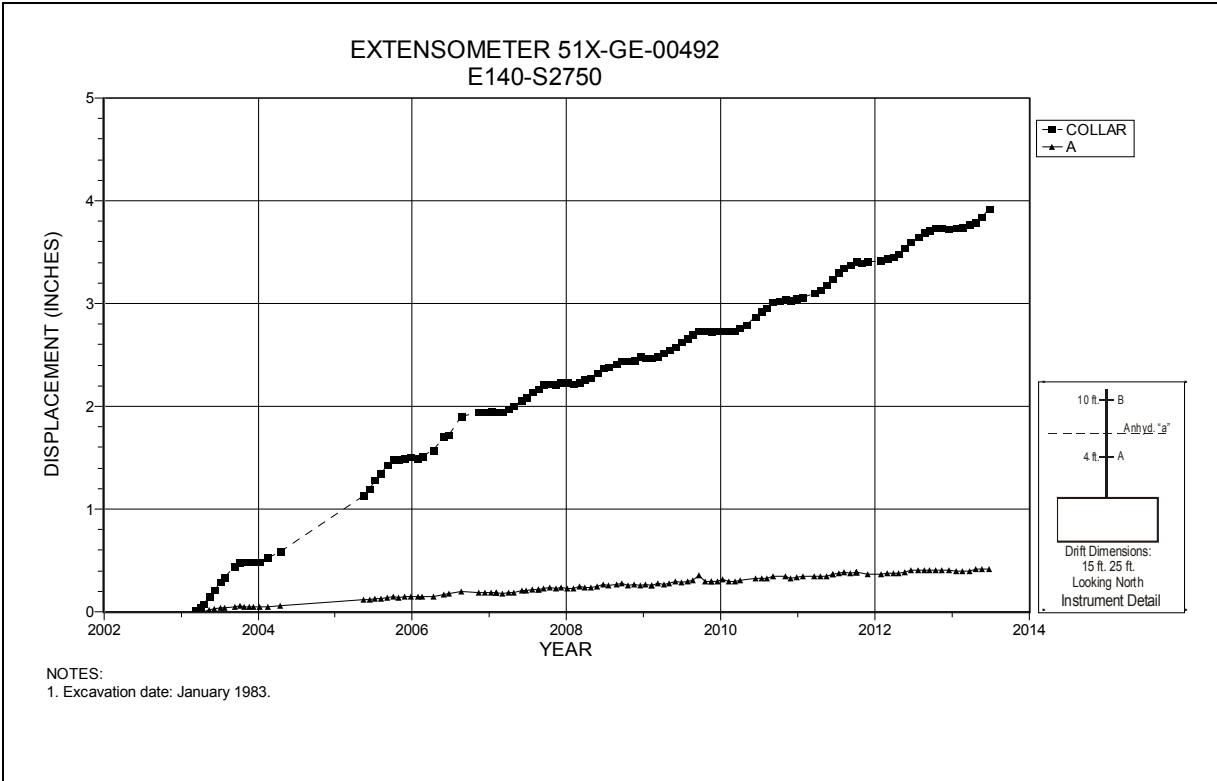

Figure 4-21 Extensometer 51X-GE-00492
E140 S2750 – Roof

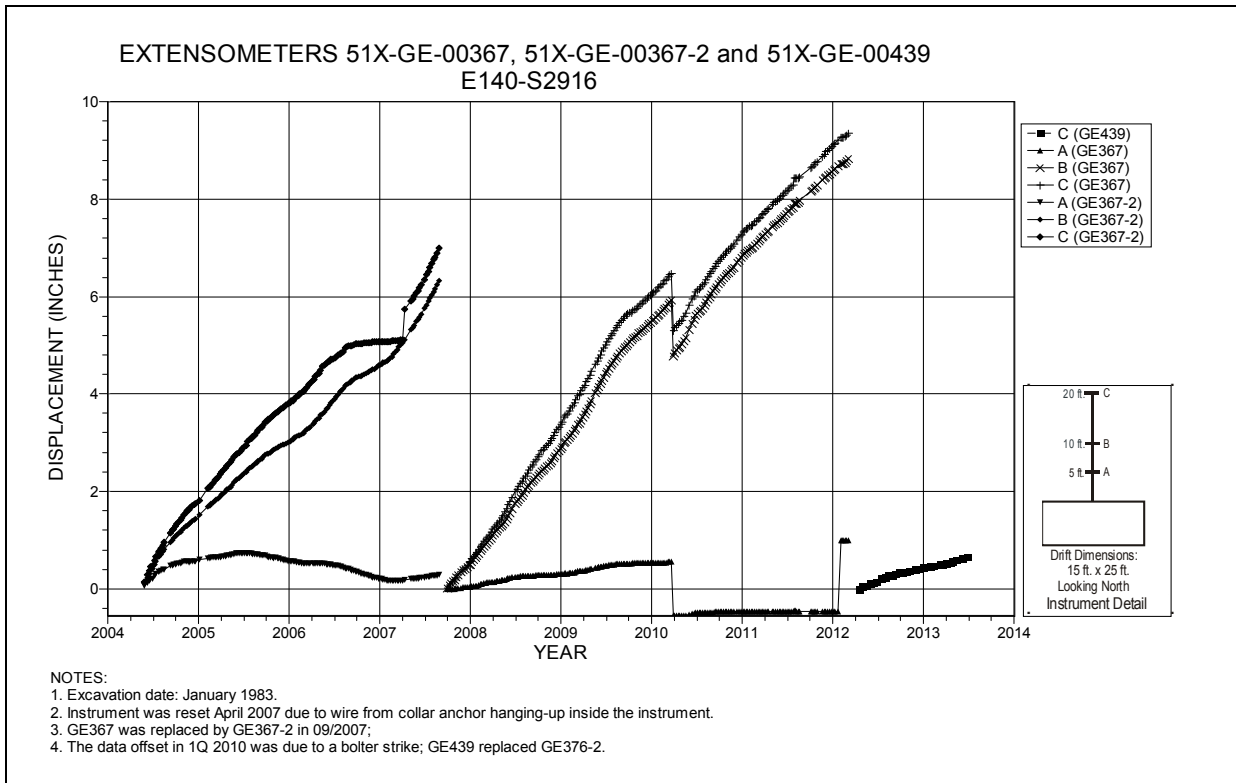

Figure 4-22 Extensometers 51X-GE-00367, 51X-GE-00367-2 and 51X-GE-00439
E140 S2916 – Roof

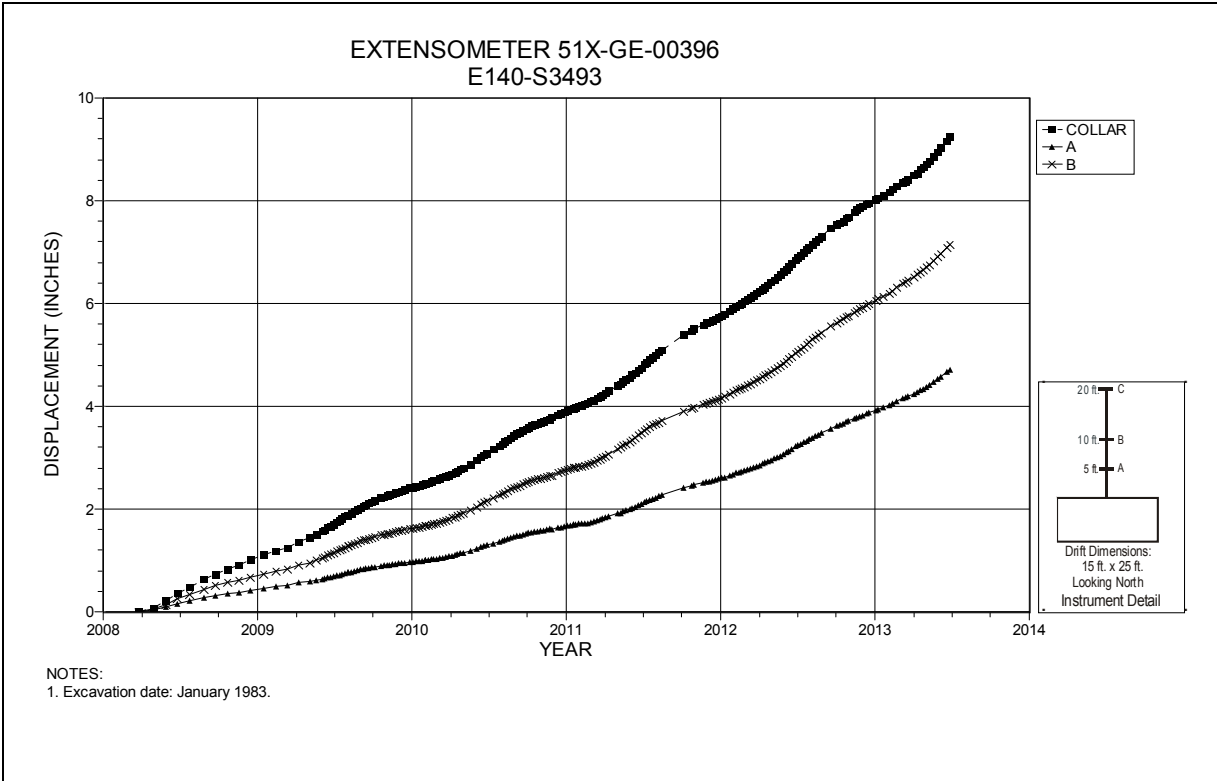

Figure 4-23 Extensometer 51X-GE-00396
E140 S3493 – Roof

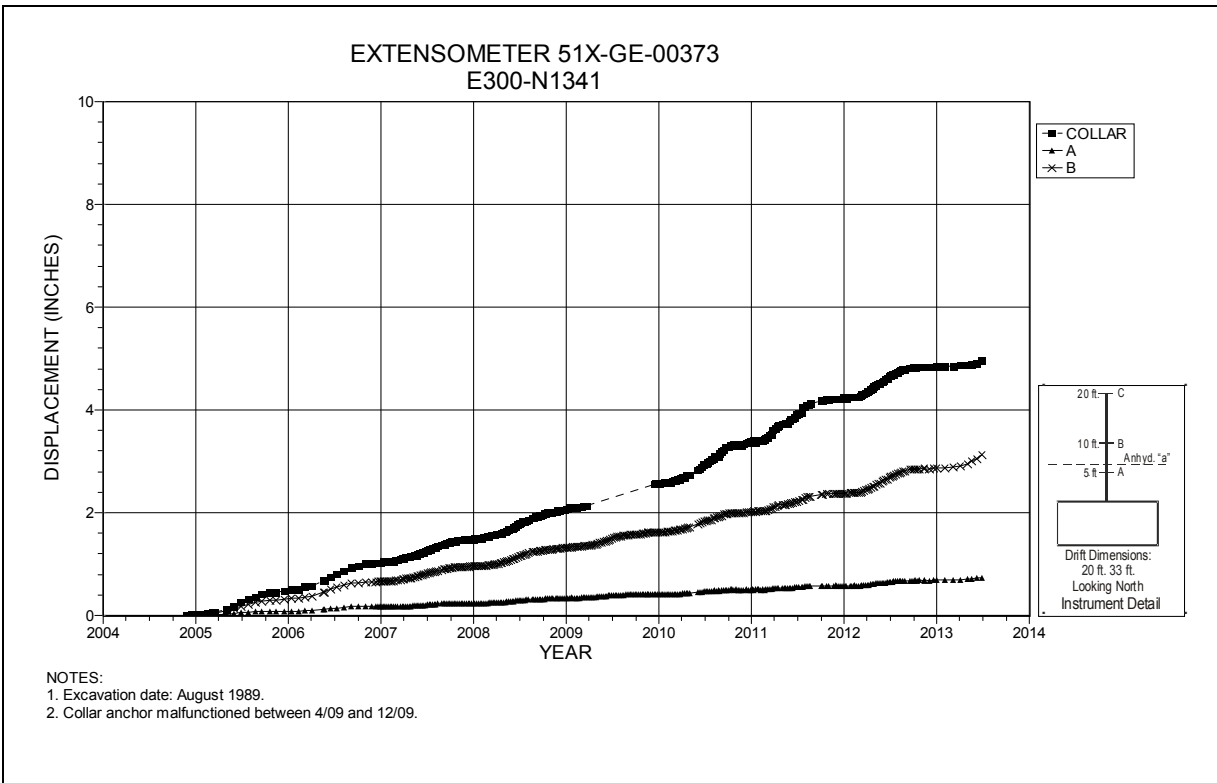

Figure 4-24 Extensometer 51X-GE-00373
E300 N1341 – Roof

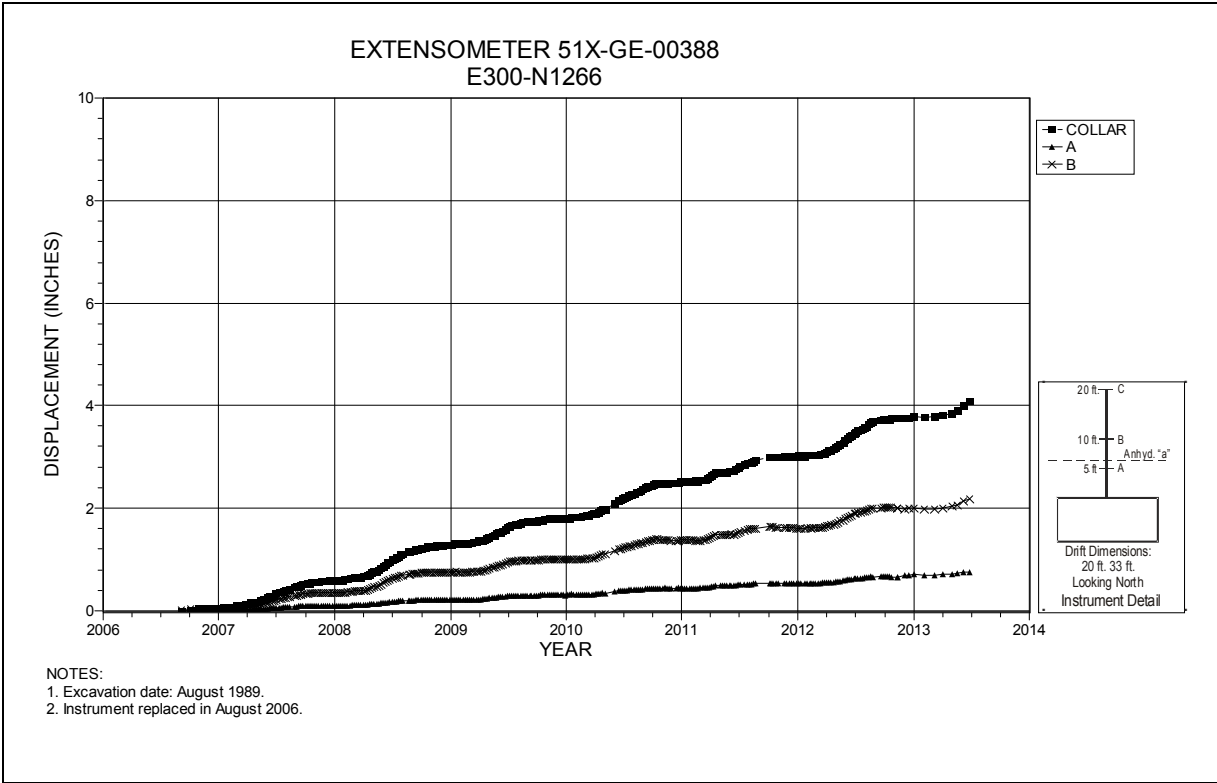

Figure 4-25 Extensometer 51X-GE-00388
E300 N1266 – Roof

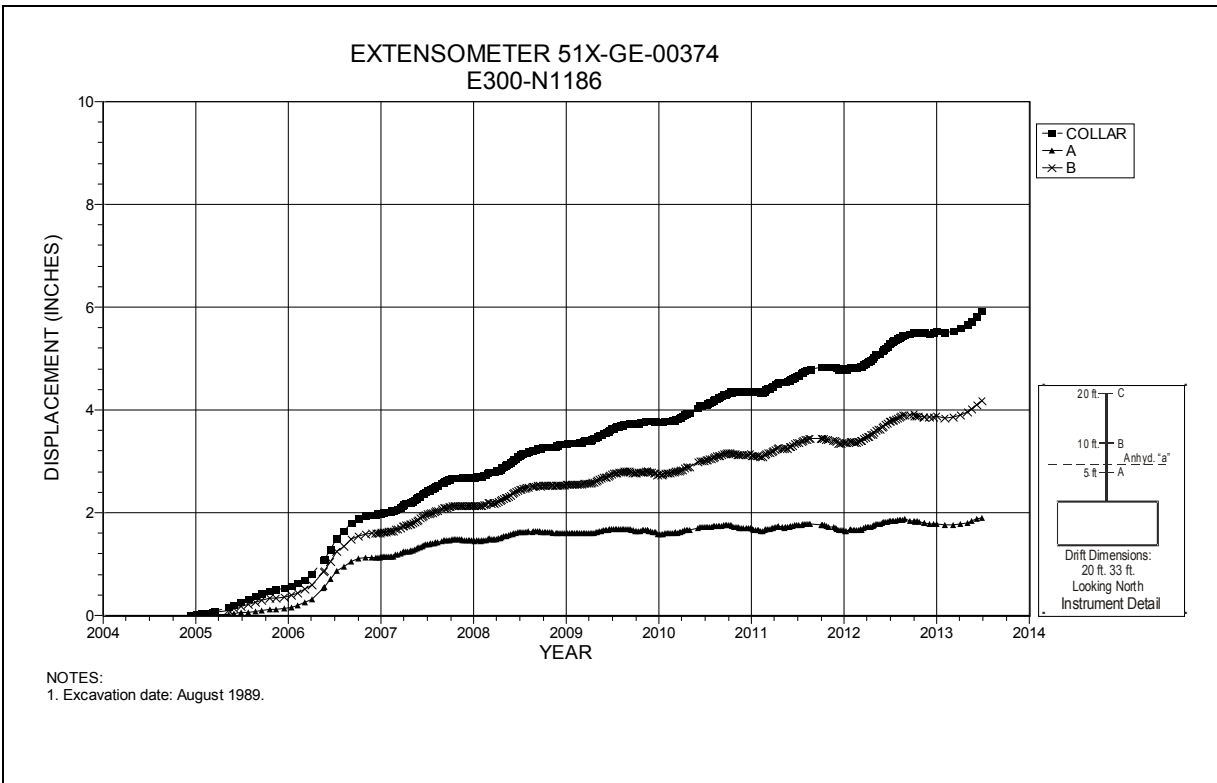

Figure 4-26 Extensometer 51X-GE-00374
E300 N1186 – Roof

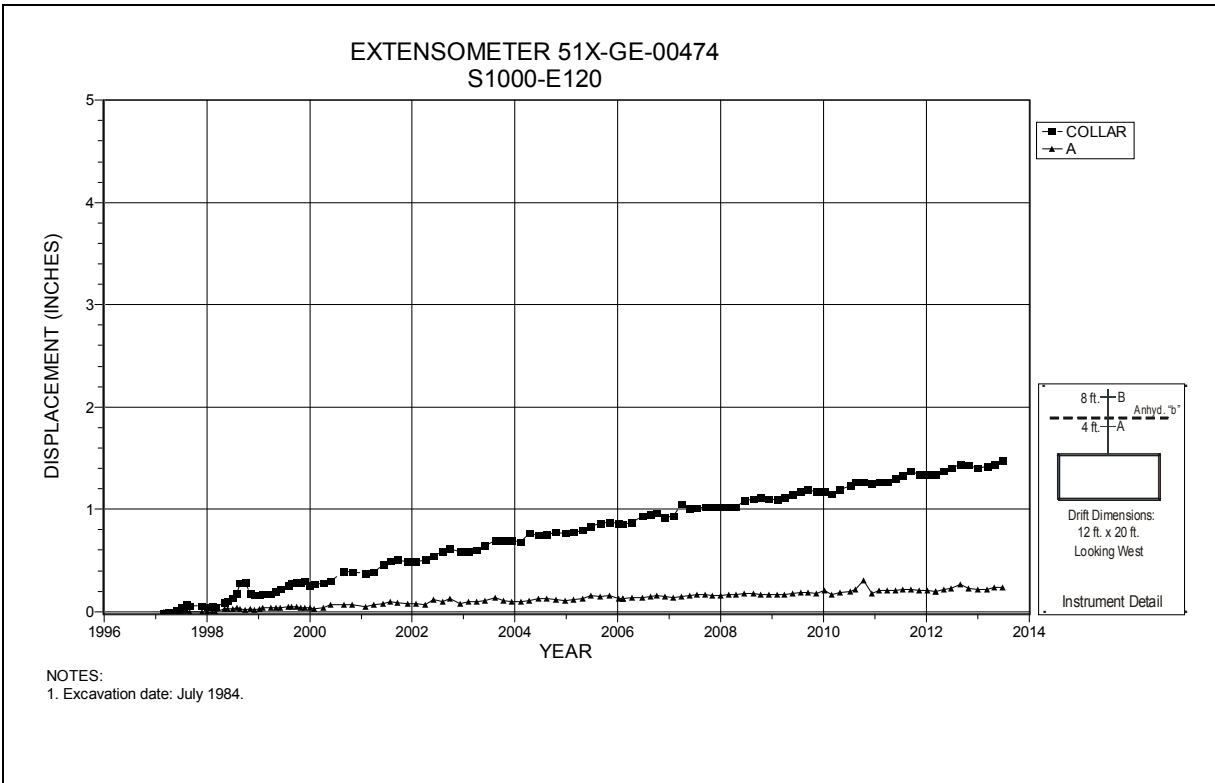

Figure 4-27 Extensometer 51X-GE-00474
S1000 E120 – Roof

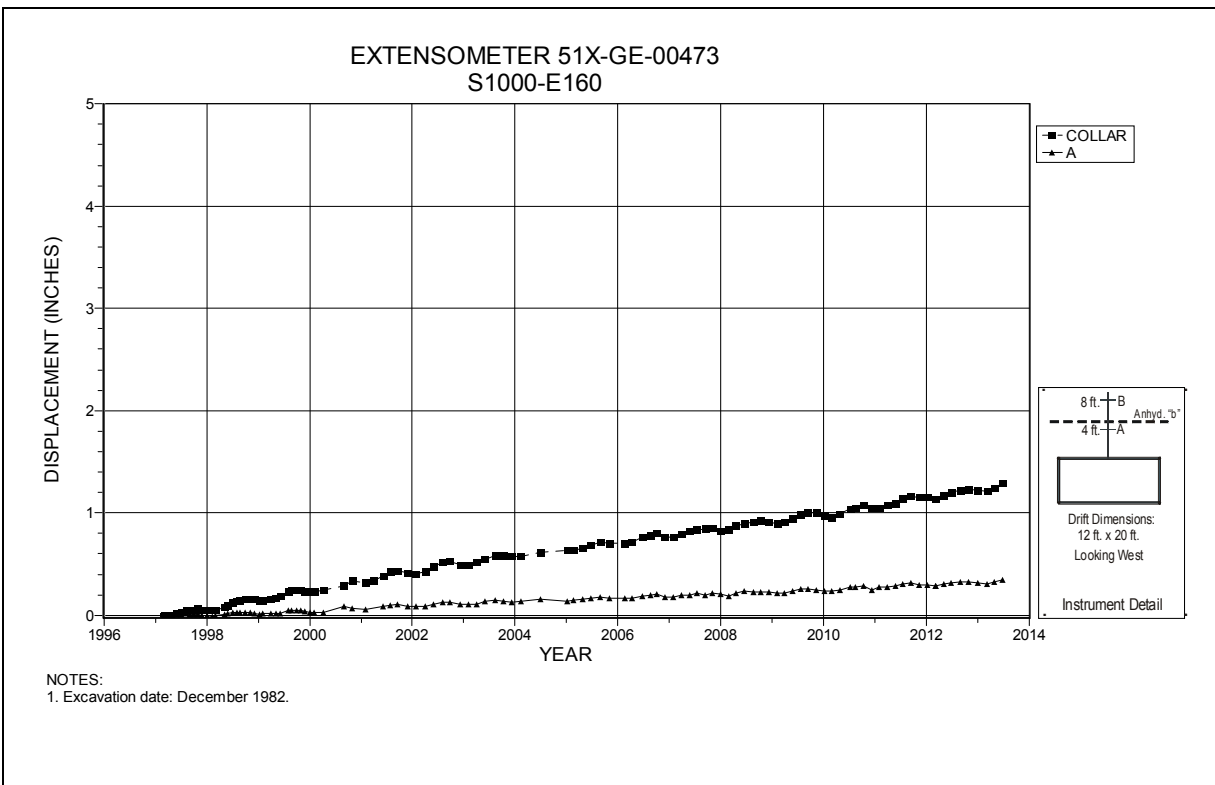

Figure 4-28 Extensometer 51X-GE-00473
S1000 E160 – Roof

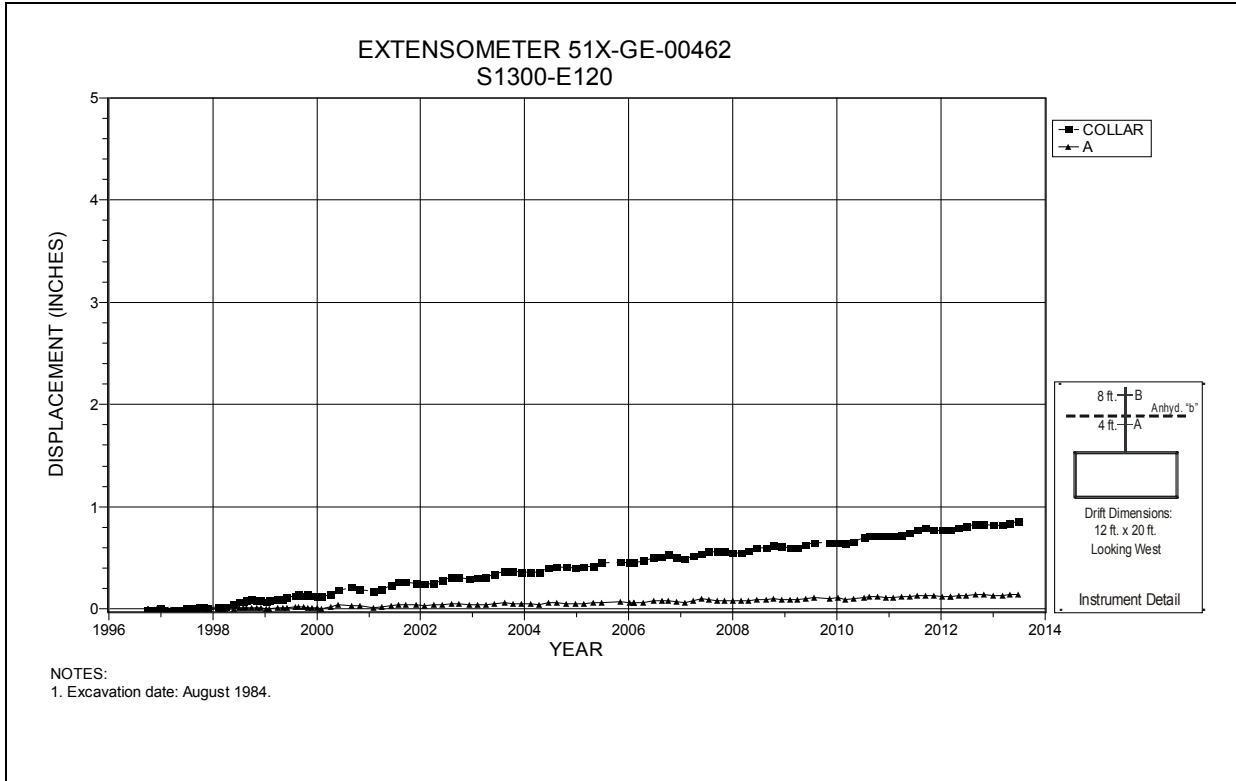

Figure 4-29 Extensometer 51X-GE-00462
S1300 E120 – Roof

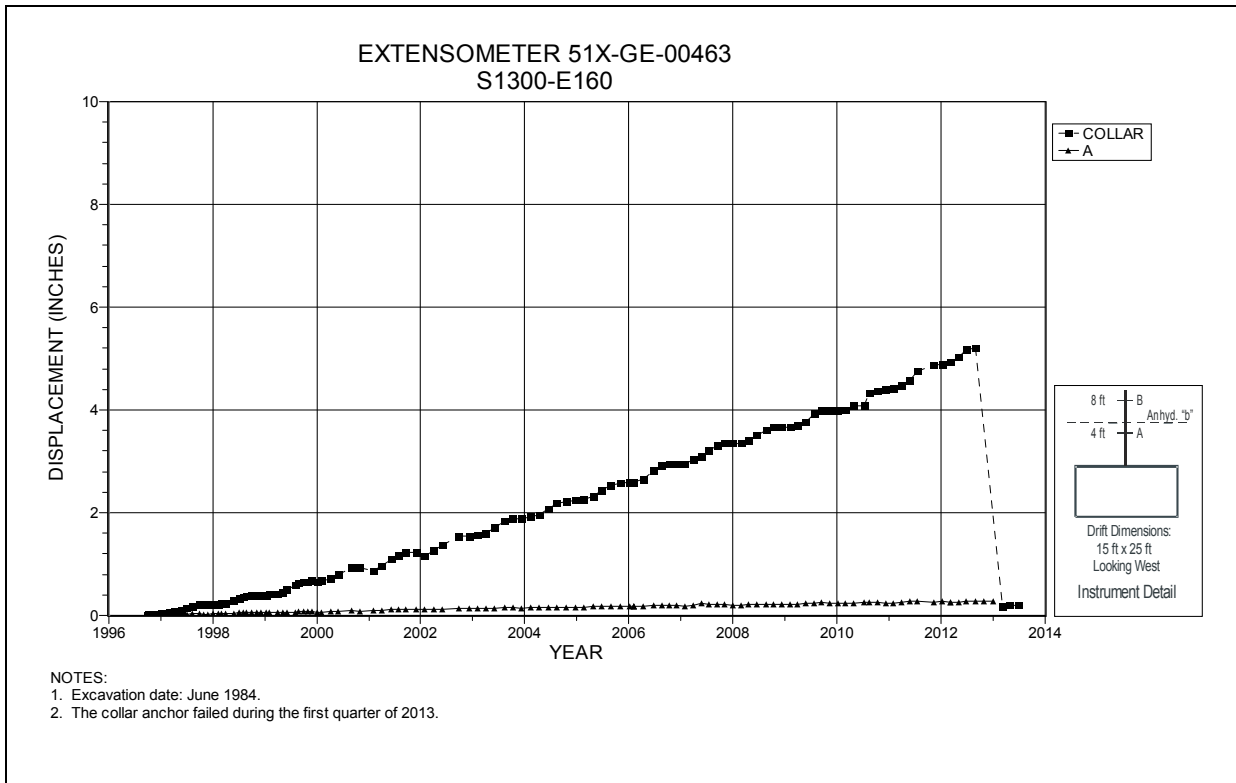

Figure 4-30 Extensometer 51X-GE-00463
S1300 E160 – Roof

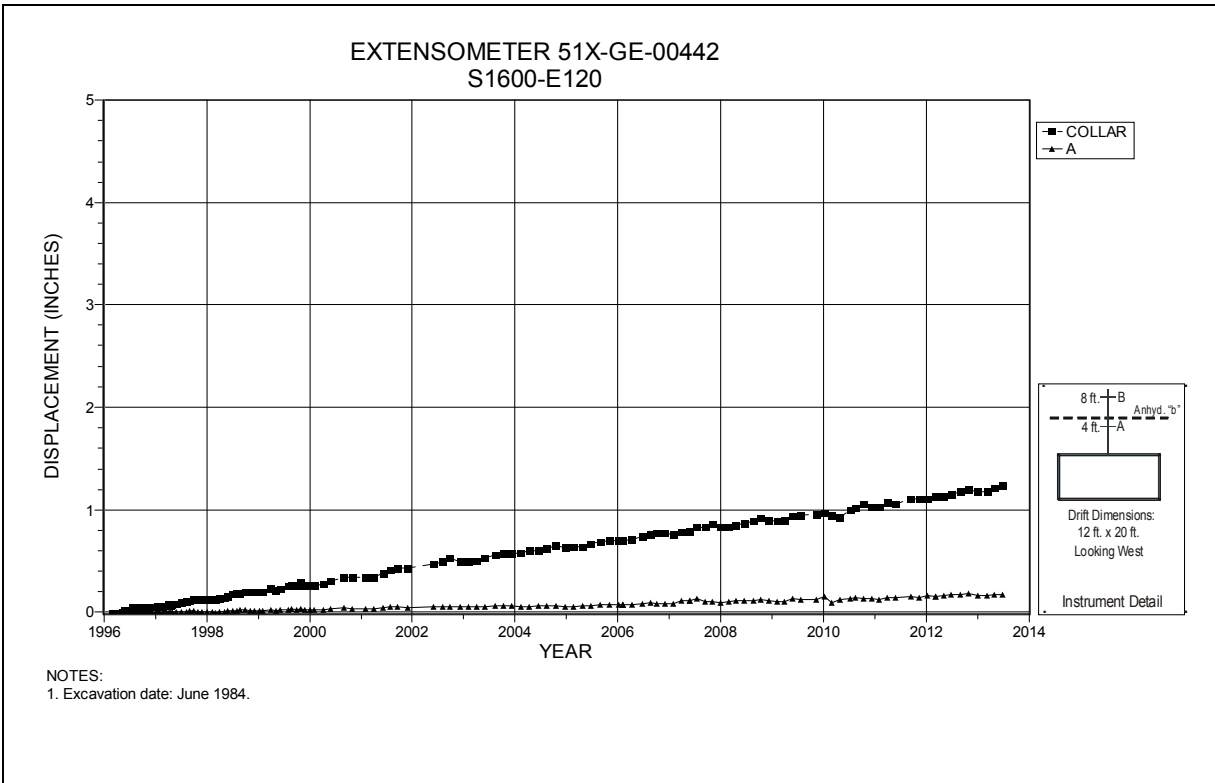

Figure 4-31 Extensometer 51X-GE-00442
S1600 E120 – Roof

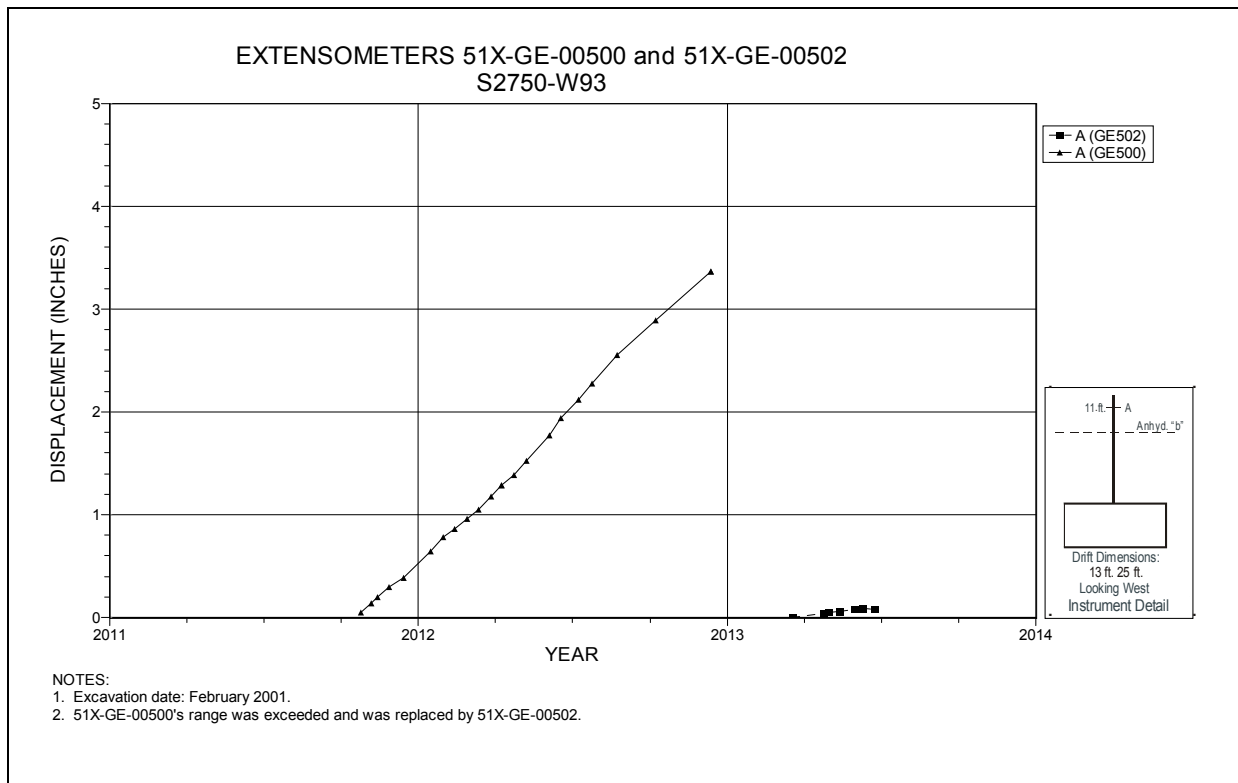

Figure 4-32 Extensometers 51X-GE-00500 and 51X-GE-00502
S2750 W93 – Roof

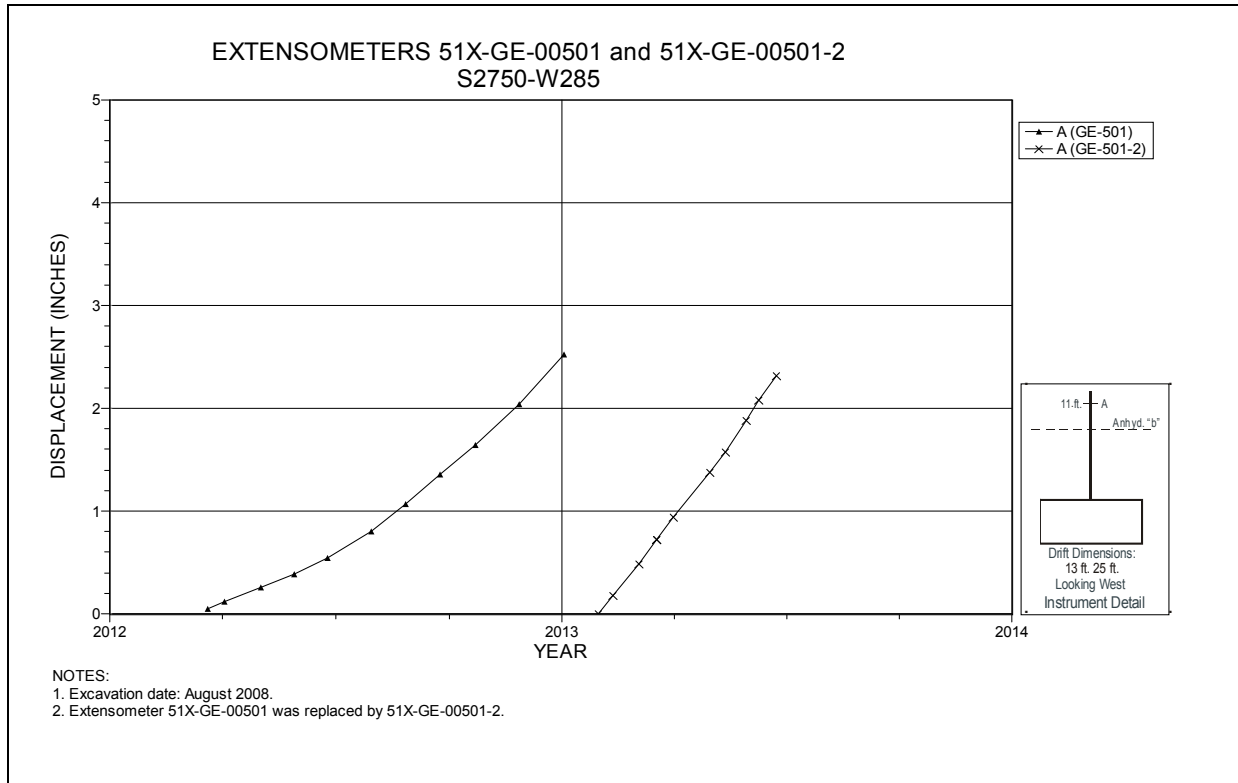

Figure 4-33 Extensometers 51X-GE-00501 and 51X-GE-00501-2
S2750 W285 – Roof

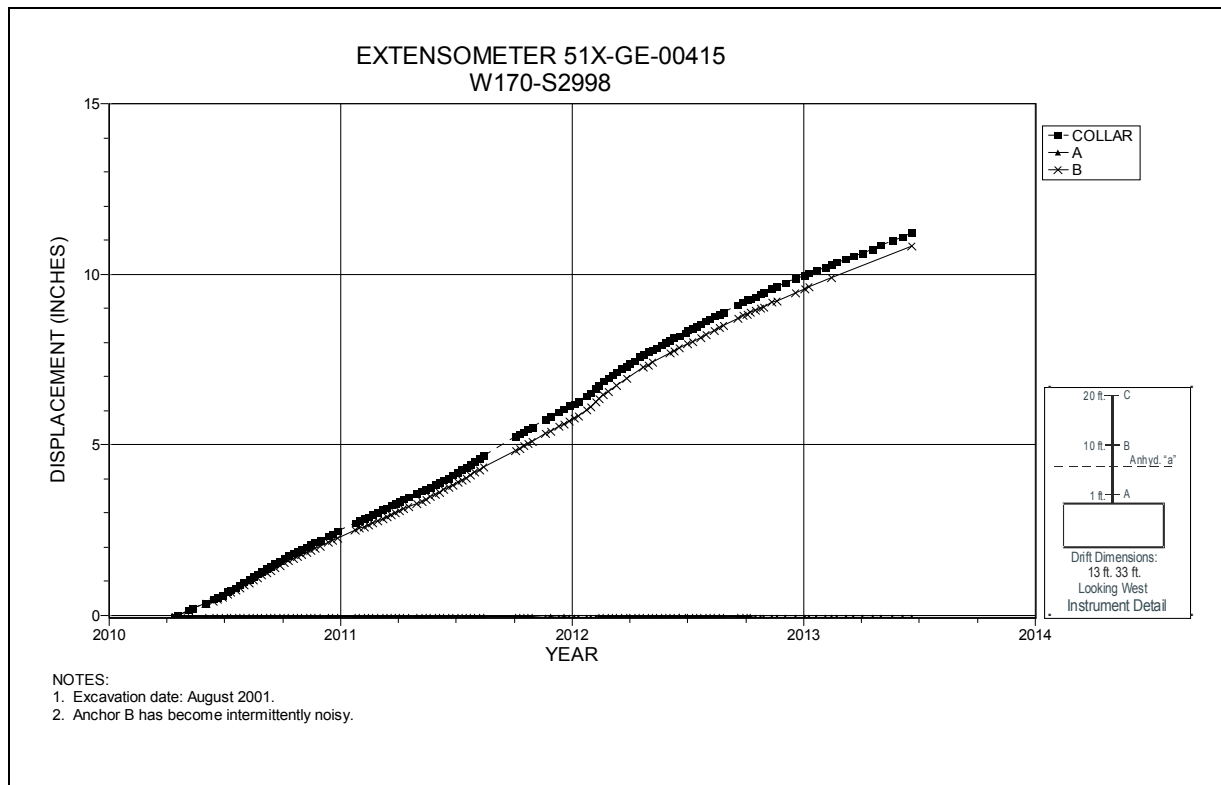

Figure 4-34 Extensometer 51X-GE-00415
W170 S2998 – Roof

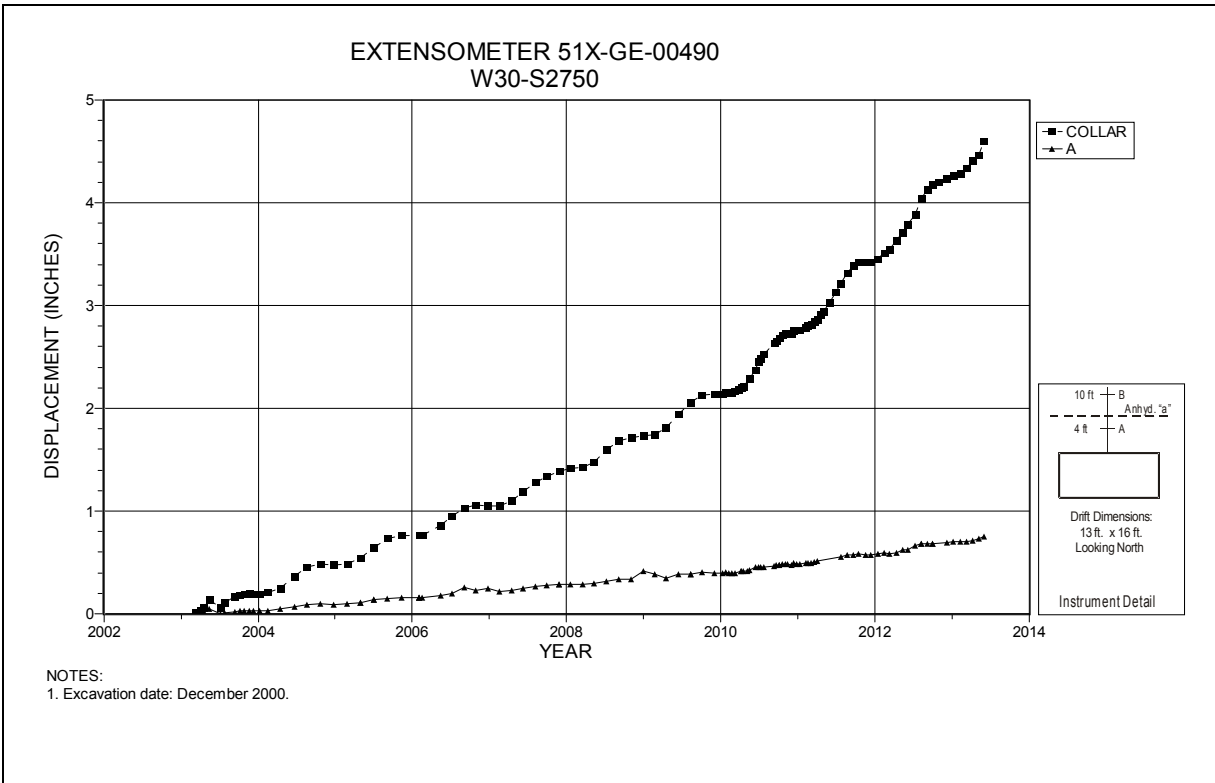

Figure 4-35 Extensometer 51X-GE-00490
W30 S2750 – Roof

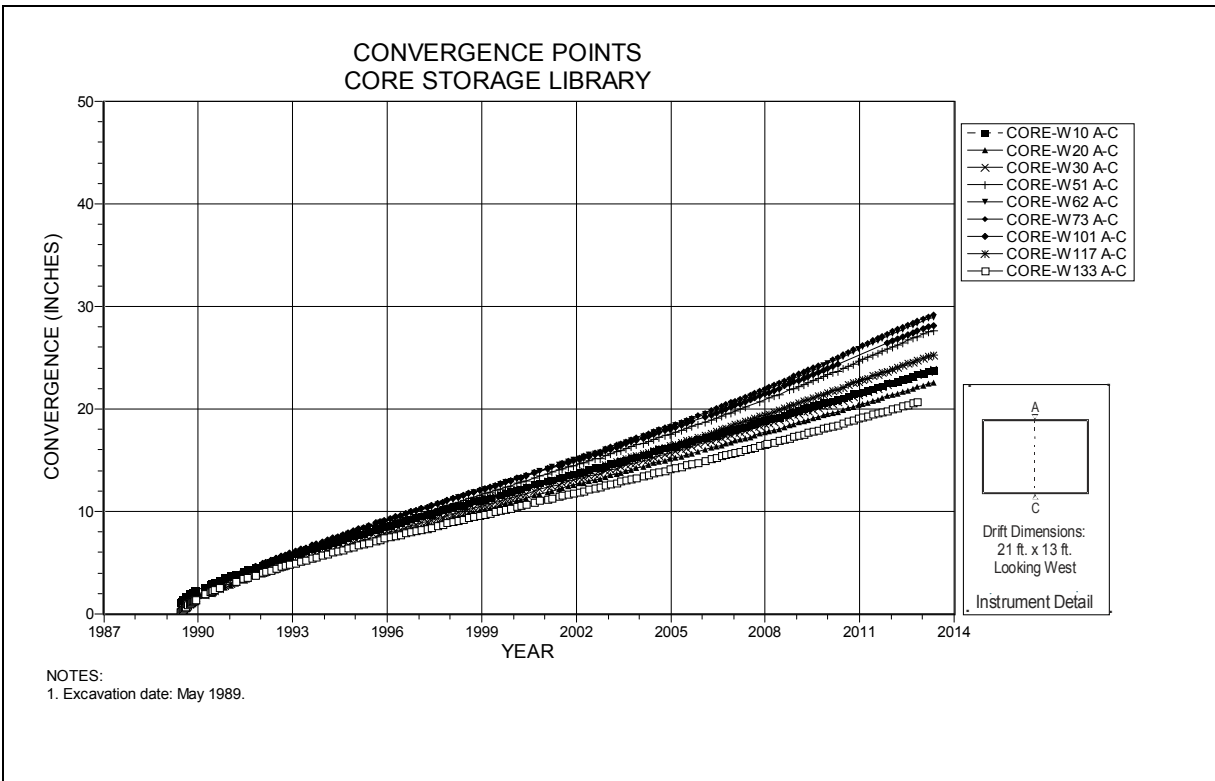
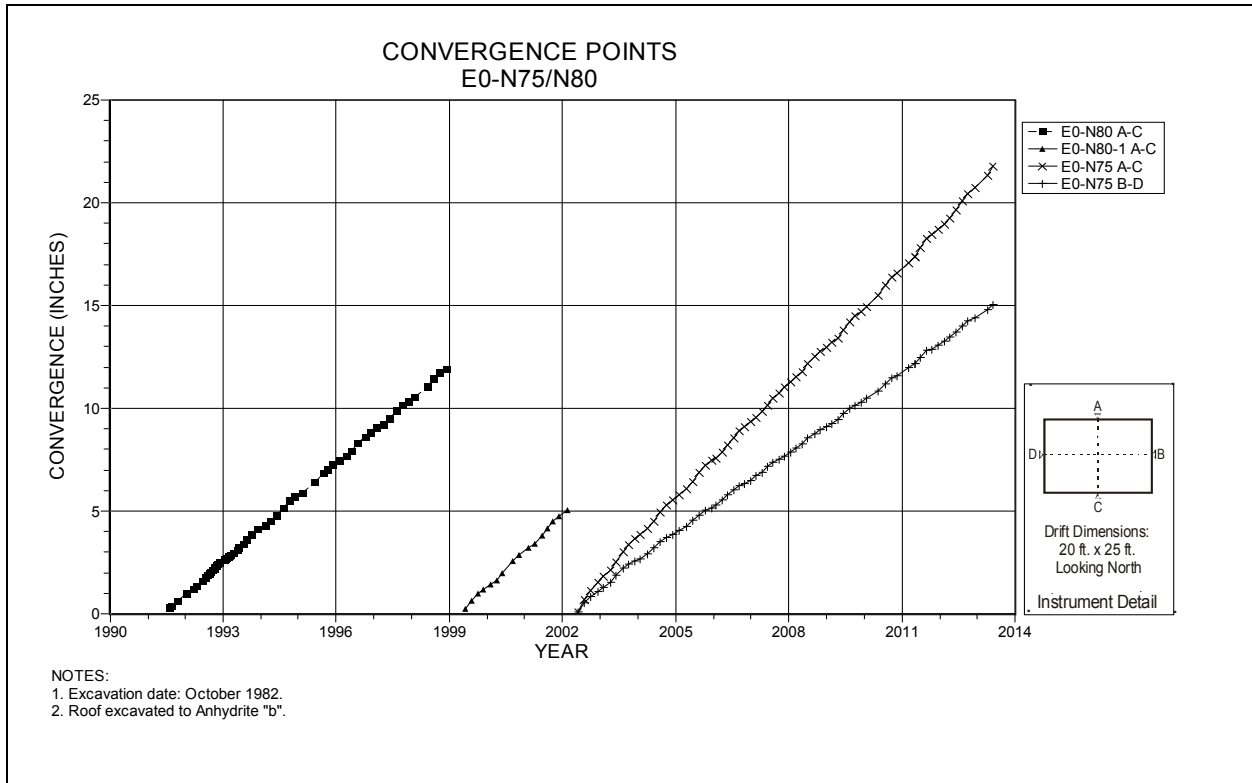
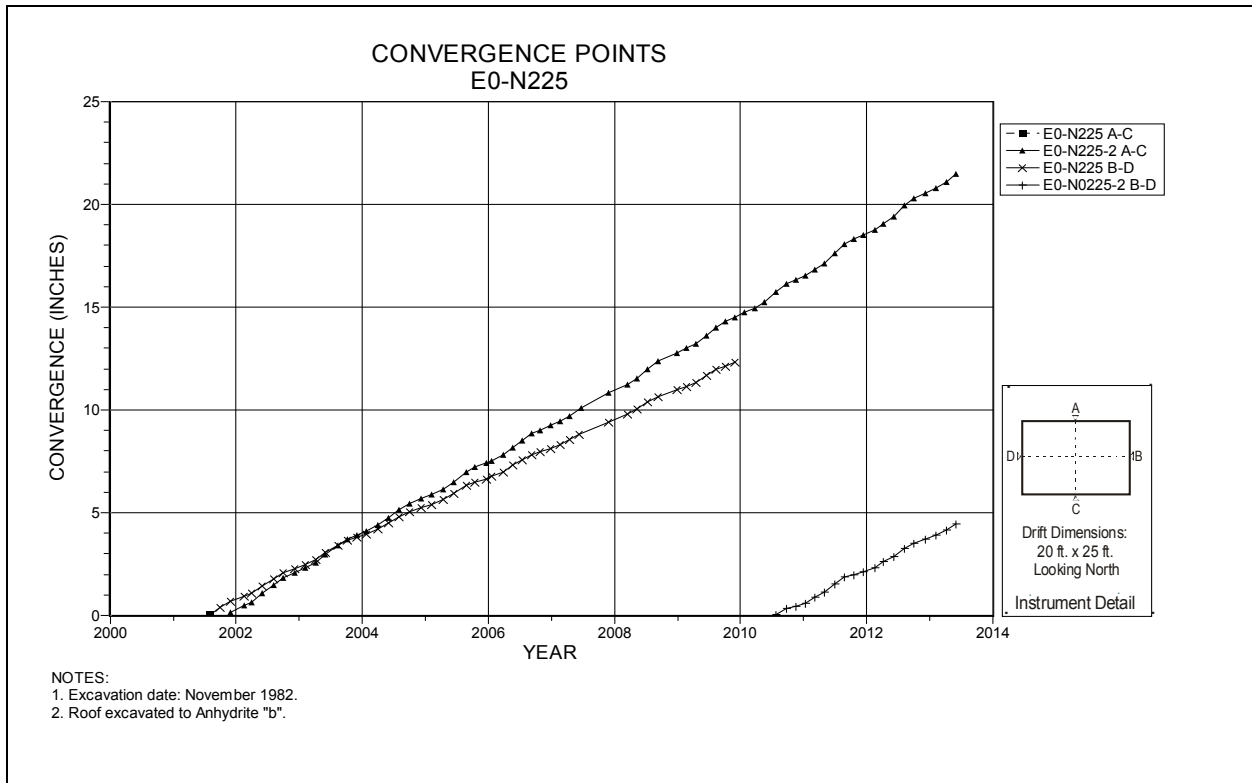

Figure 4-36 Convergence Point Array
Core Storage Library – Roof to Floor



**Figure 4-37 Convergence Point Array
E0 N75/N80 – All Chords**



**Figure 4-38 Convergence Point Array
E0 N225 – All Chords**

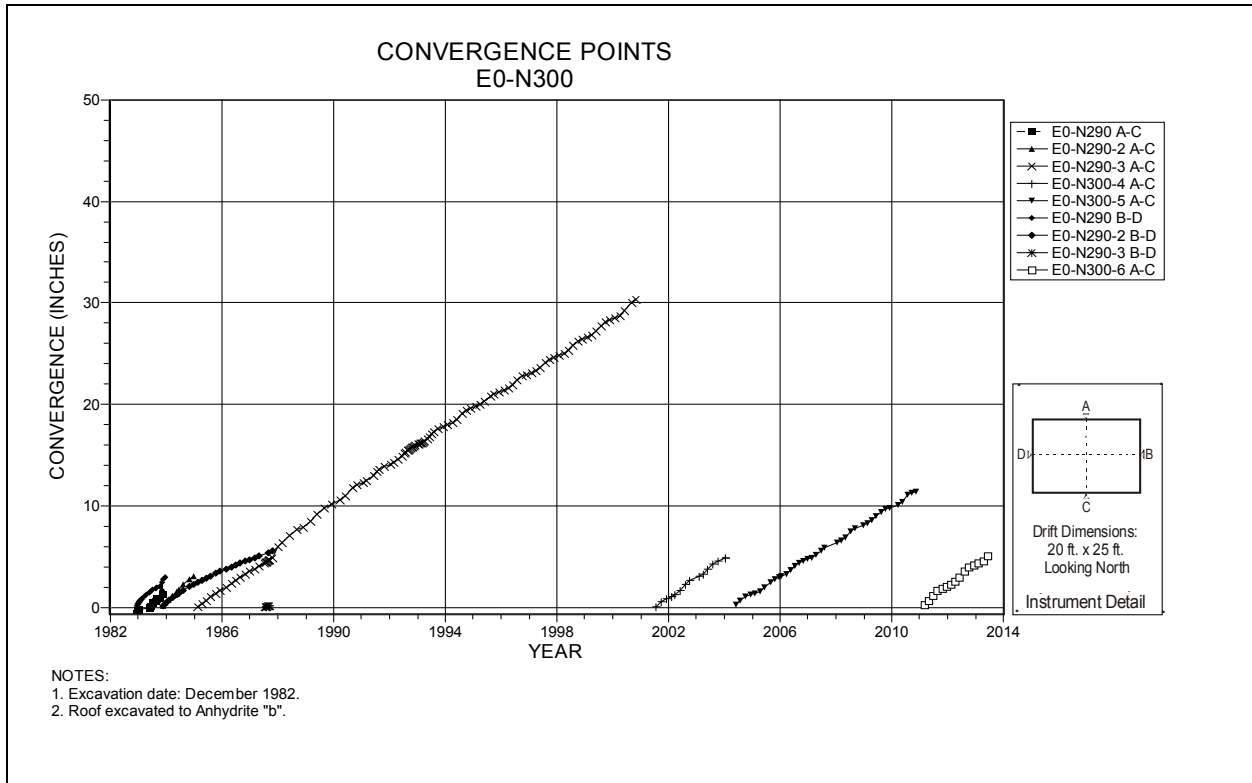

**Figure 4-39 Convergence Point Array
E0 N300 – All Chords**

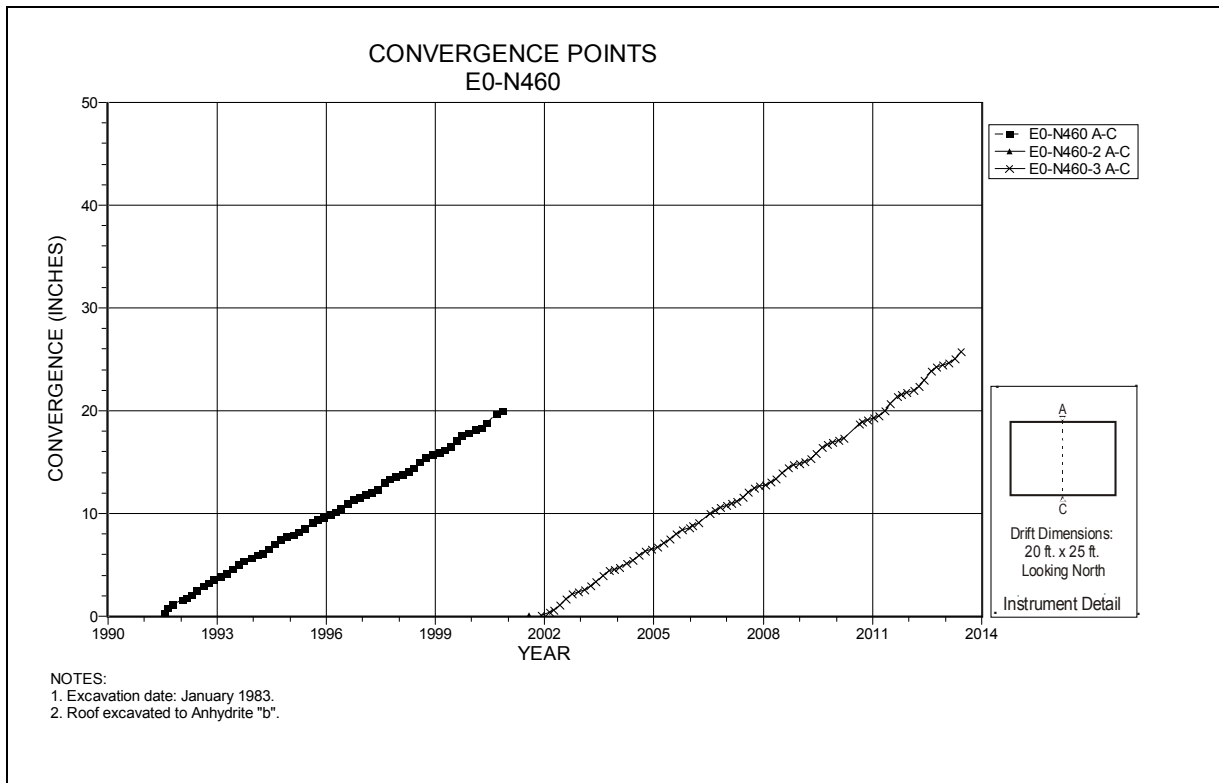

**Figure 4-40 Convergence Point Array
E0 N460 – Roof to Floor**

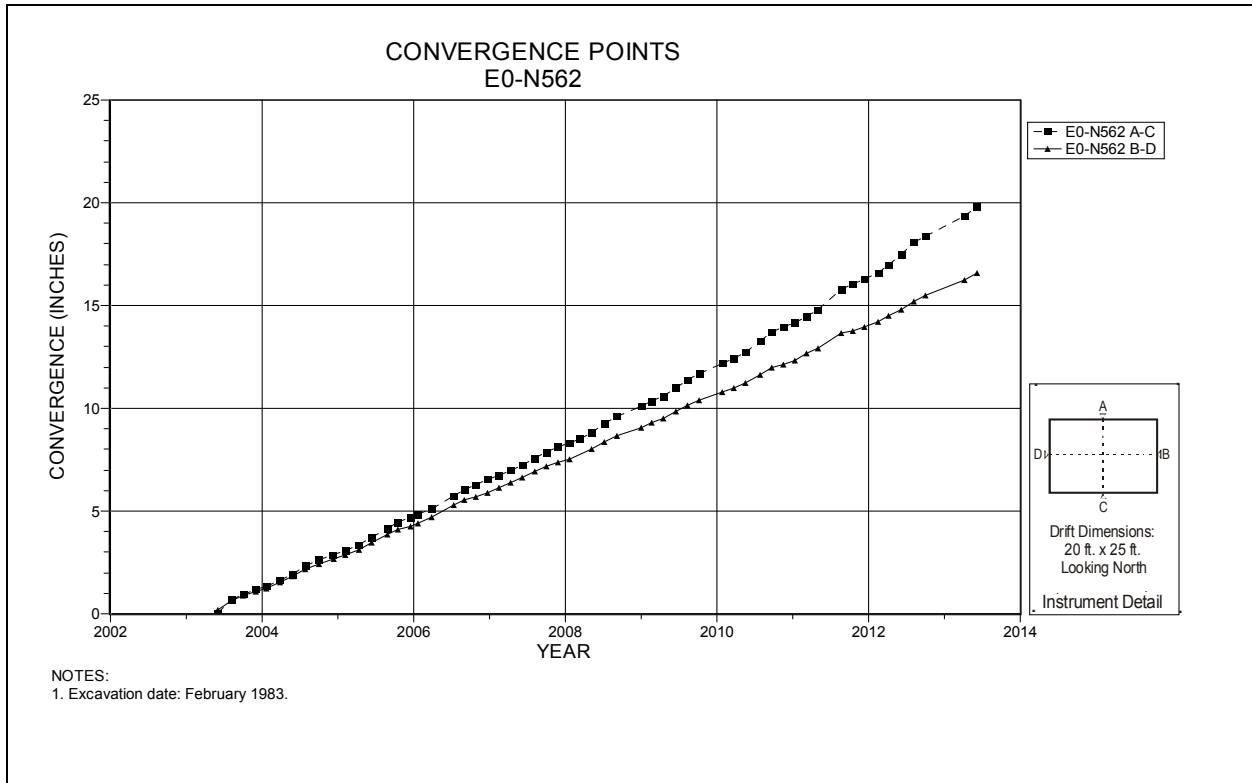

Figure 4-41 Convergence Point Array
E0 N562 – All Chords

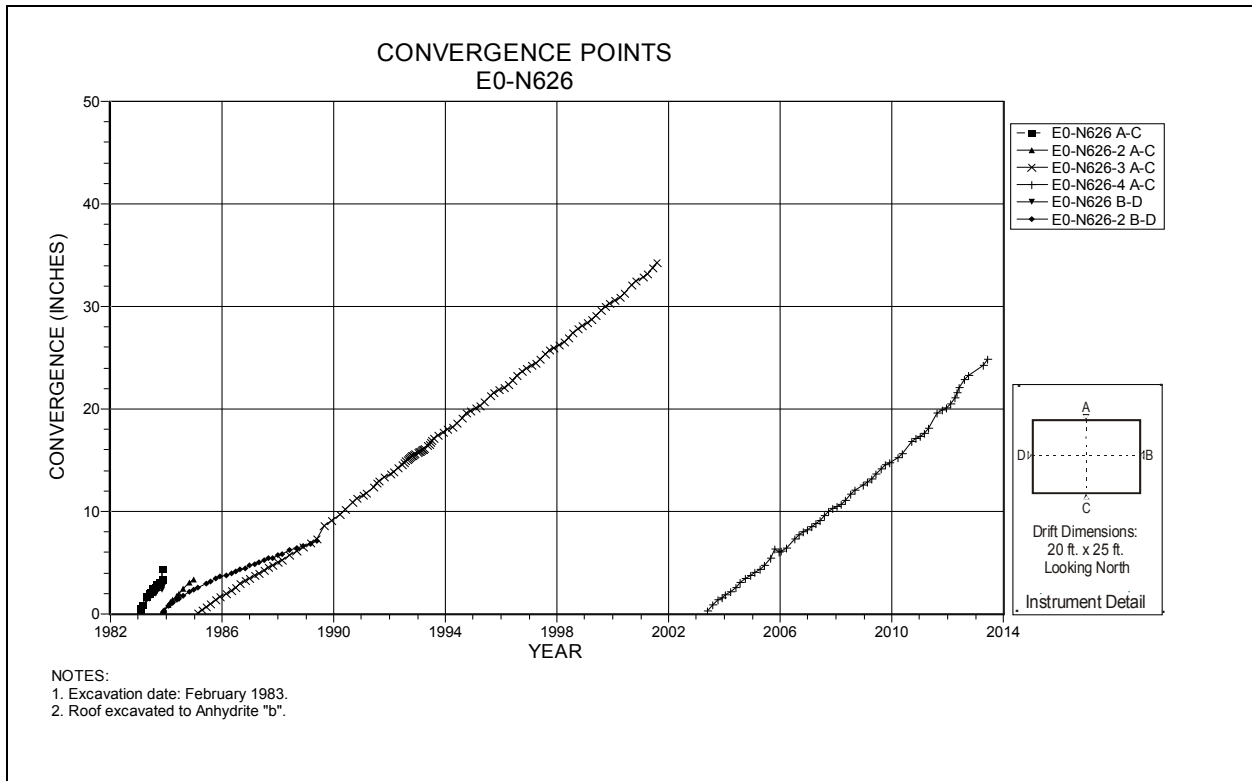

Figure 4-42 Convergence Point Array
E0 N626 – All Chords

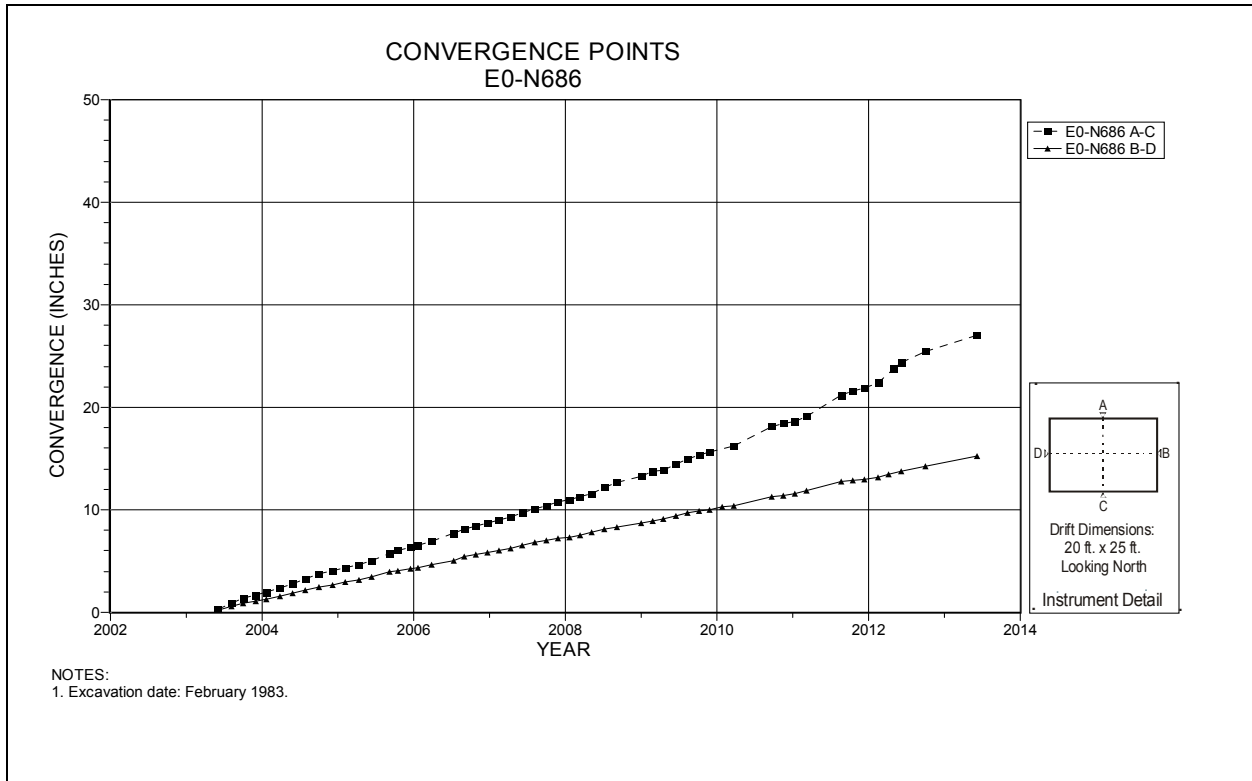

Figure 4-43 Convergence Point Array
E0 N686 – All Chords

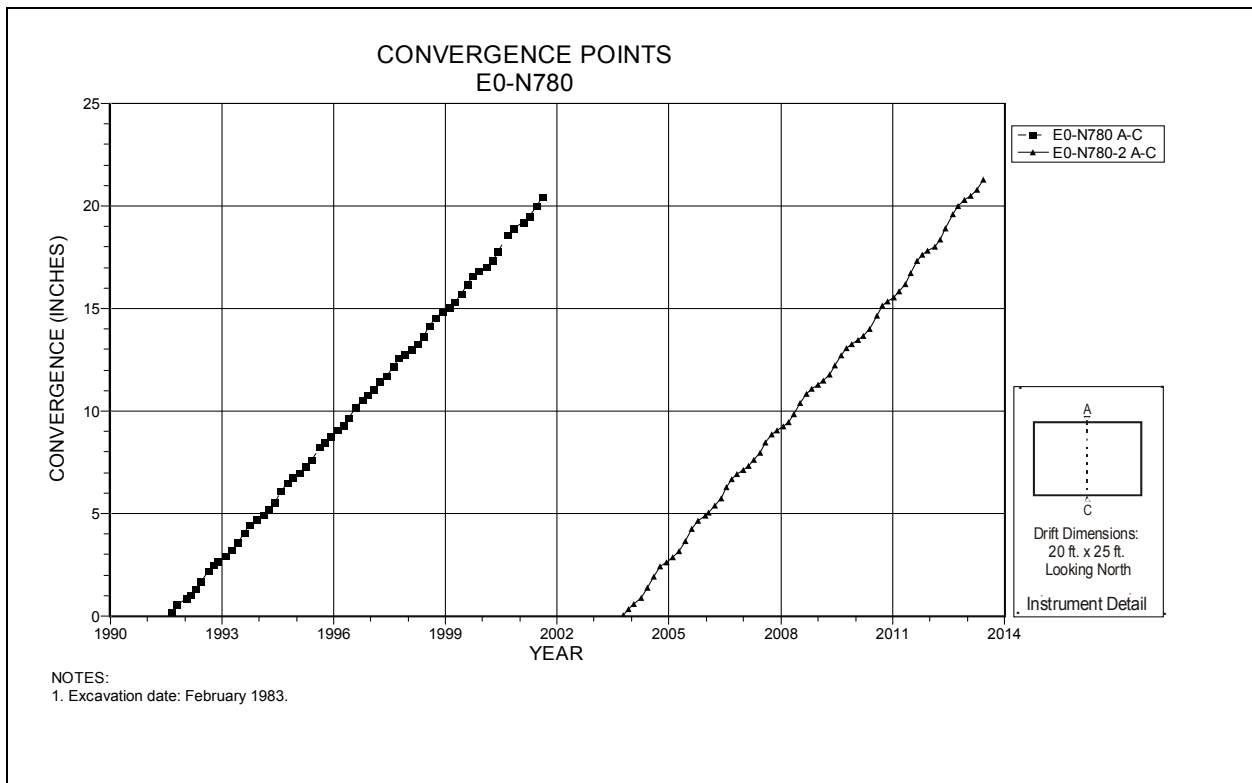
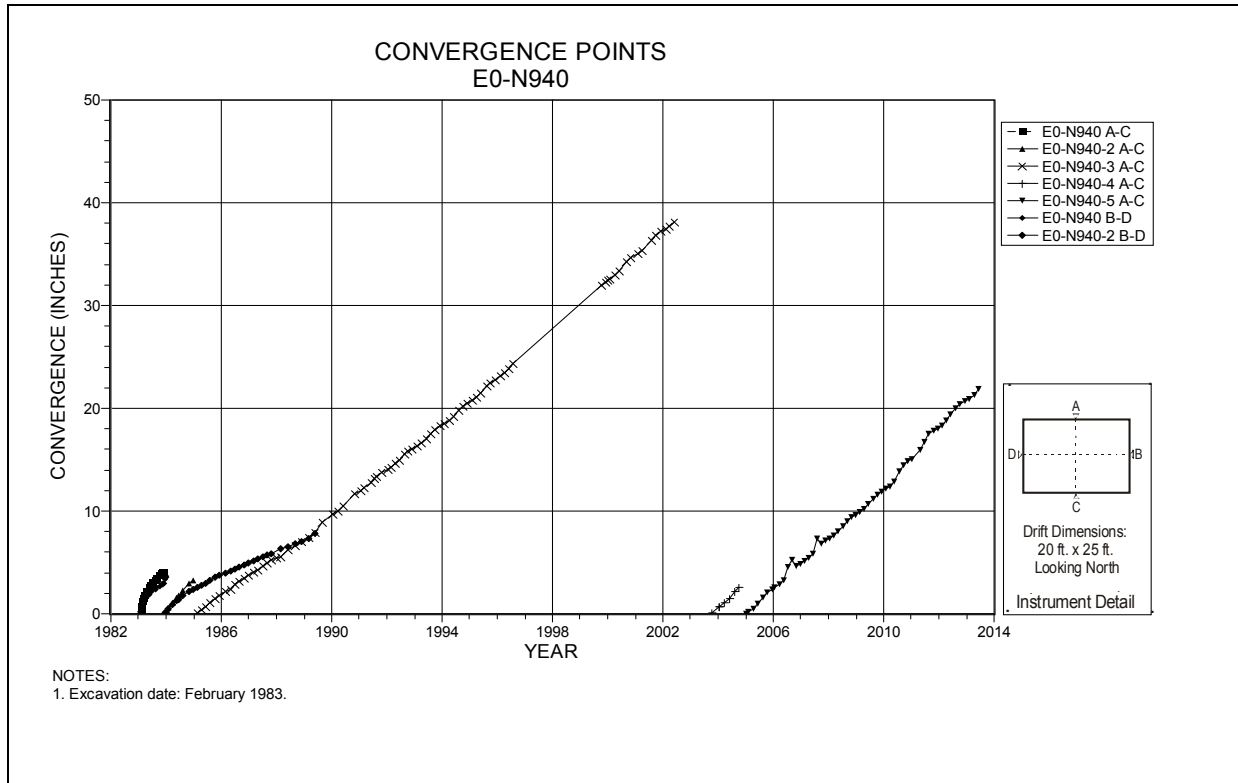
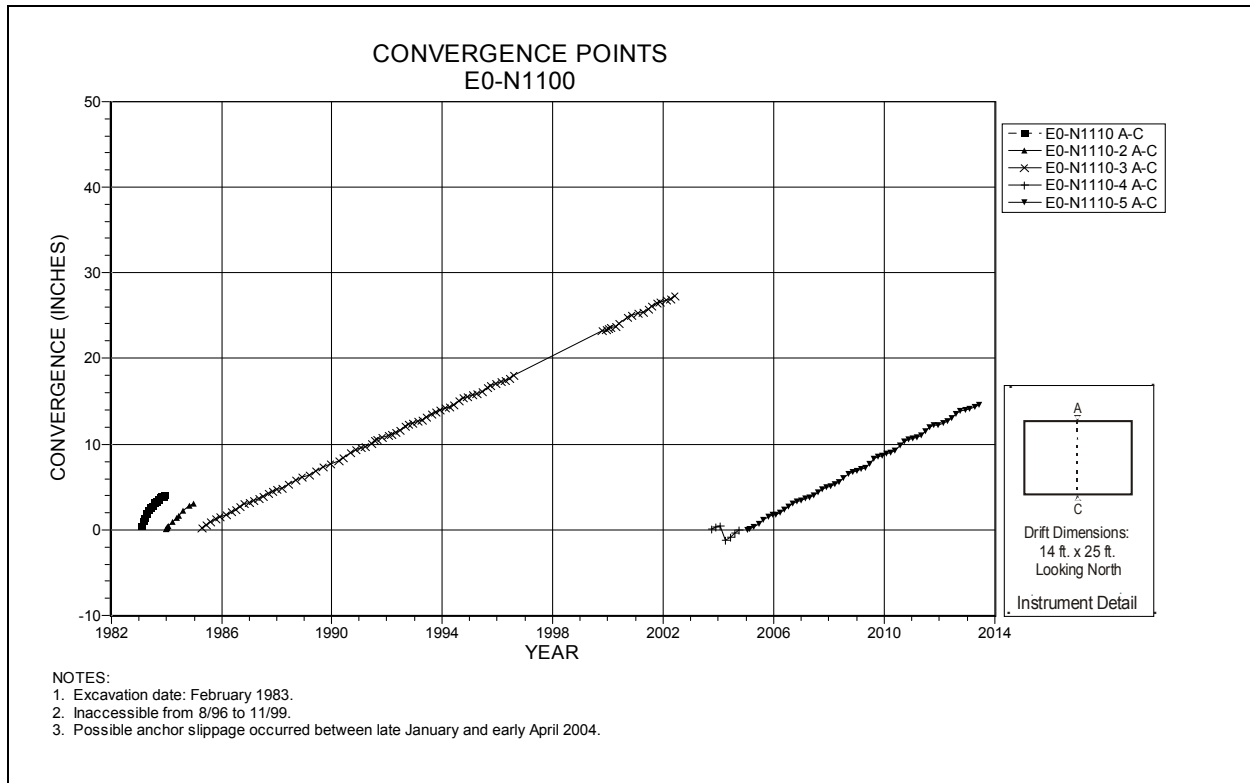

Figure 4-44 Convergence Point Array
E0 N780 – Roof to Floor



**Figure 4-45 Convergence Point Array
E0 N940 – All Chords**



**Figure 4-46 Convergence Point Array
E0 N1100 – Roof to Floor**

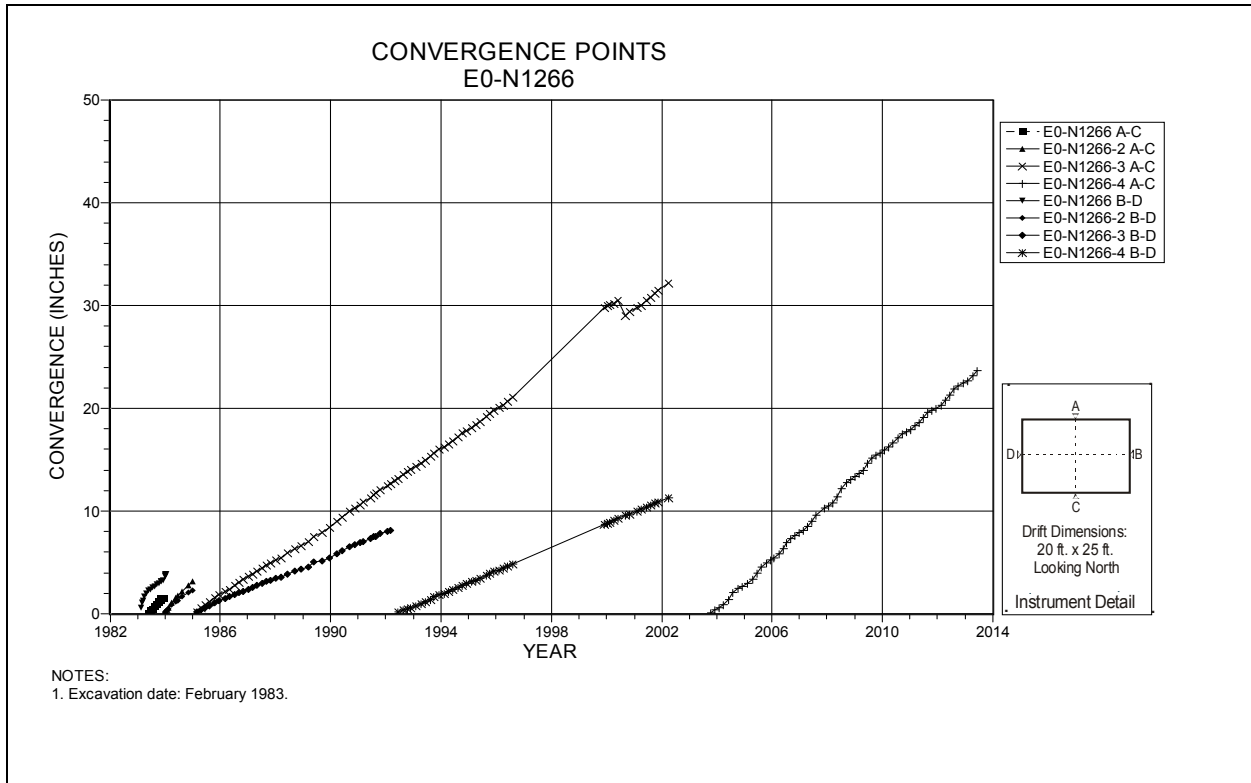

**Figure 4-47 Convergence Point Array
E0 N1266 – All Chords**

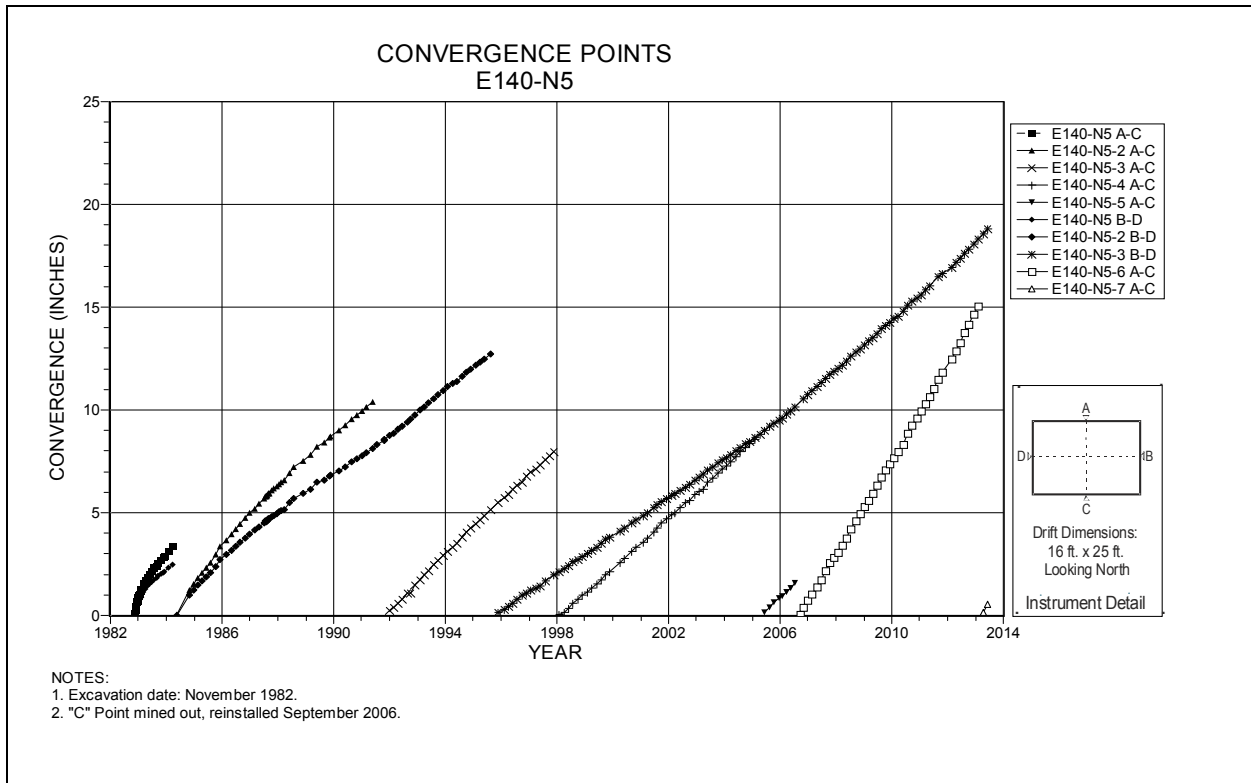

**Figure 4-48 Convergence Point Array
E140 N5 – All Chords**

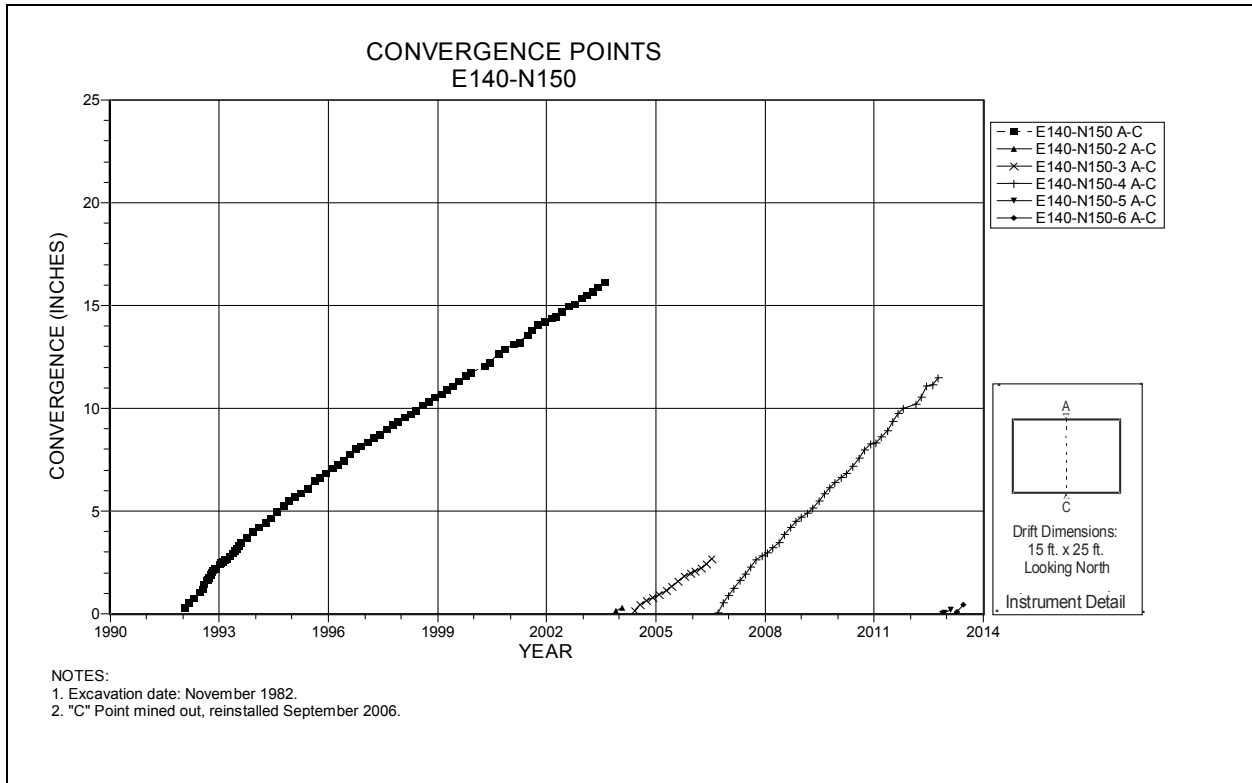

Figure 4-49 Convergence Point Array
E140 N150 – Roof to Floor

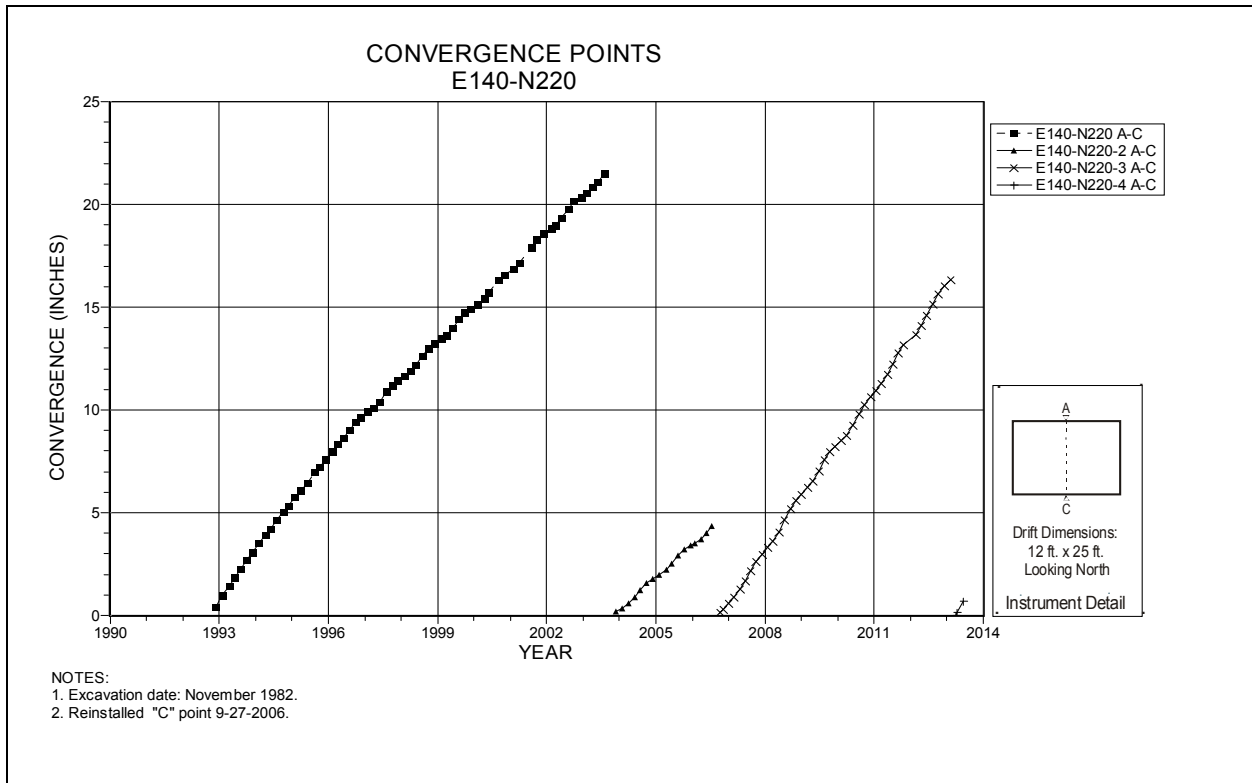
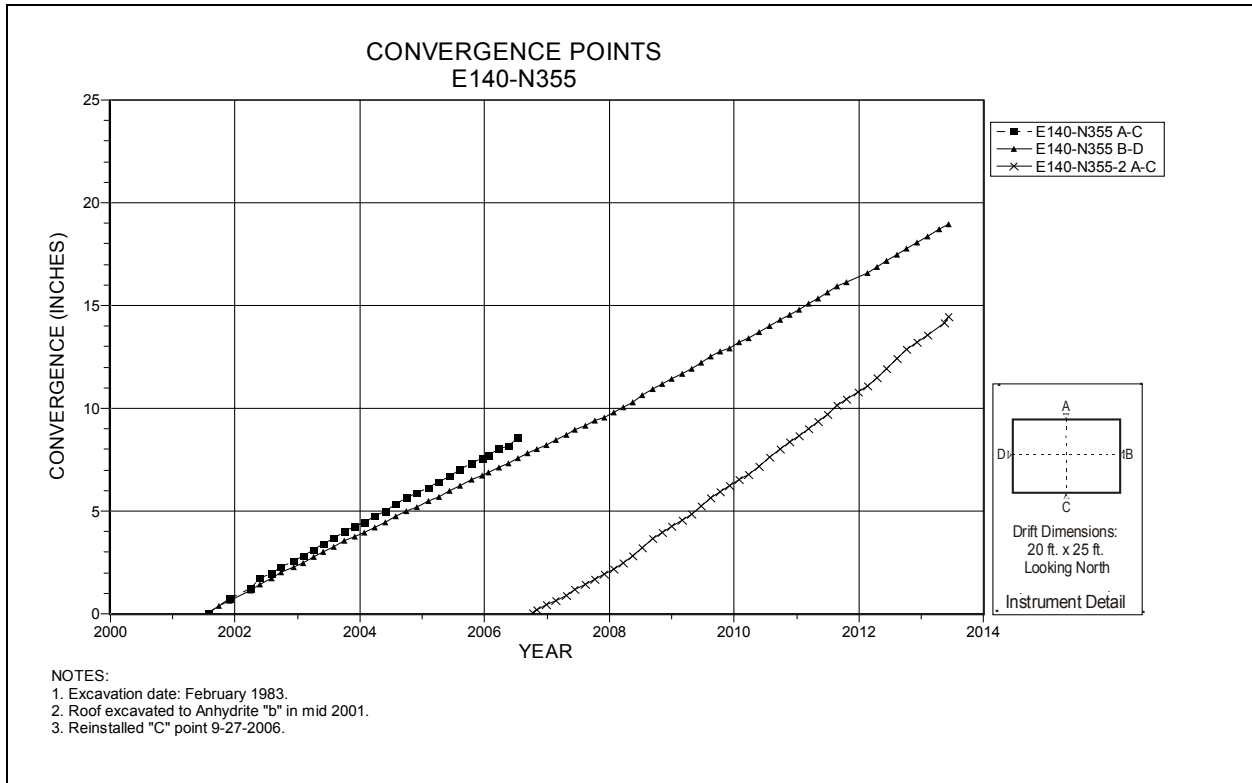
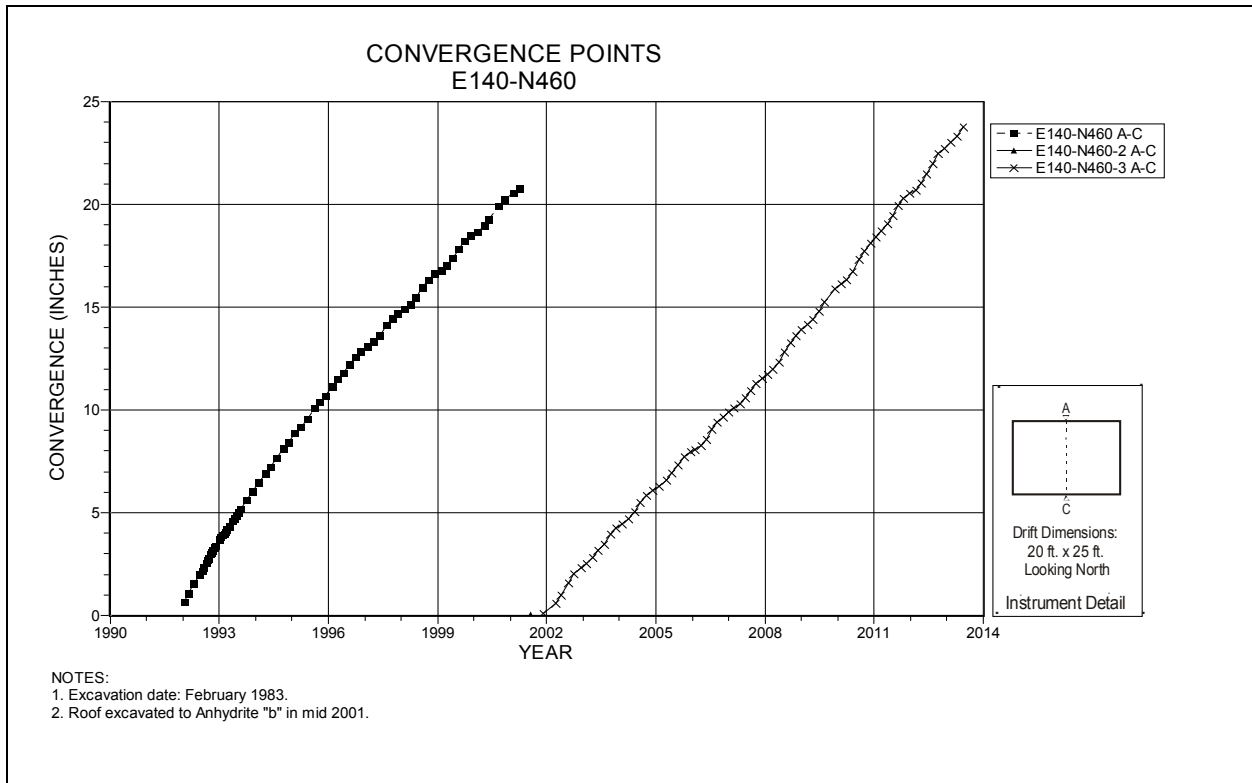

Figure 4-50 Convergence Point Array
E140 N220 – Roof to Floor



**Figure 4-51 Convergence Point Array
E140 N355 – All Chords**



**Figure 4-52 Convergence Point Array
E140 N460 – Roof to Floor**

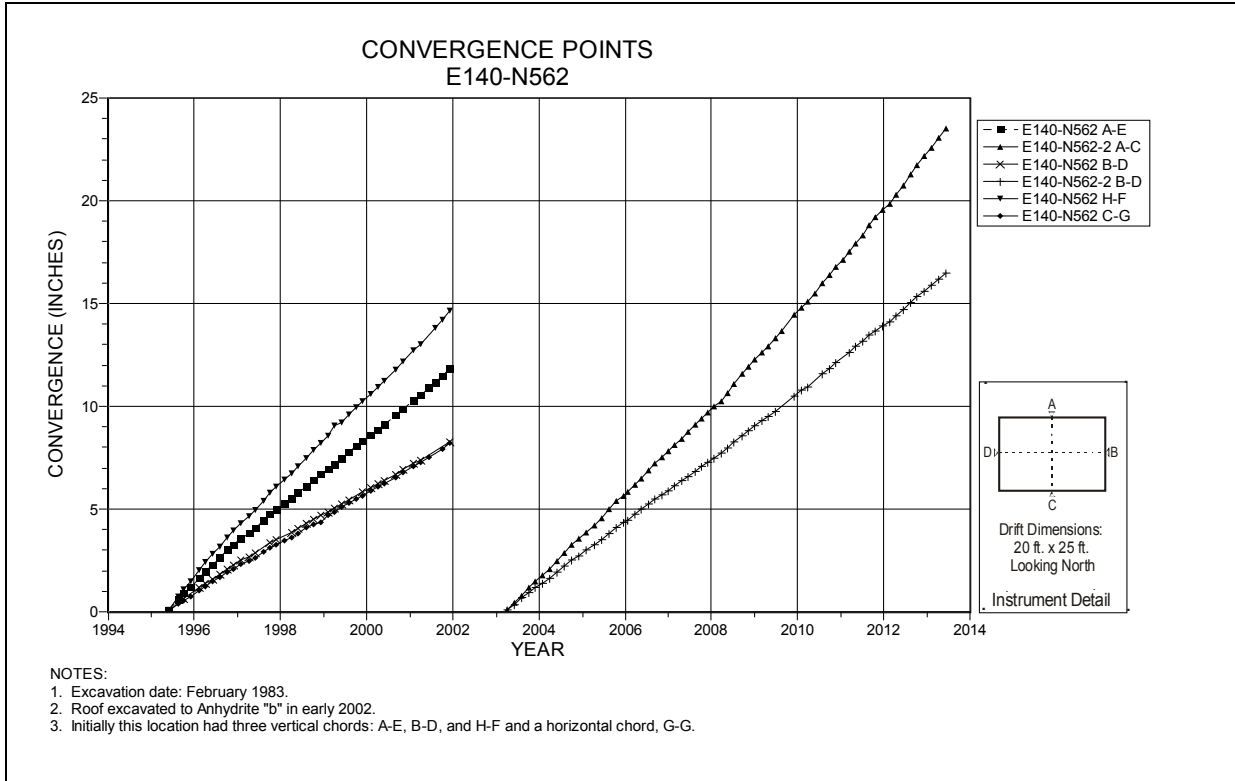

**Figure 4-53 Convergence Point Array
E140 N562 – All Chords**

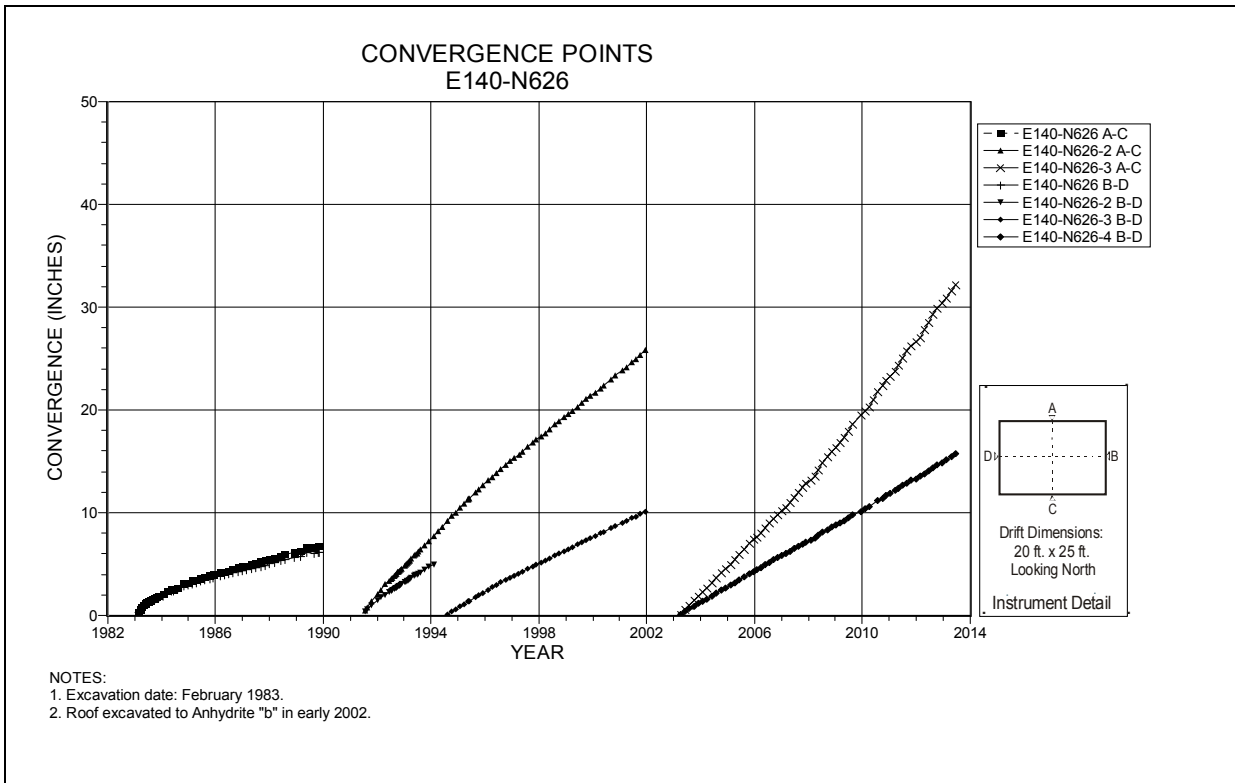

**Figure 4-54 Convergence Point Array
E140 N626 – All Chords**

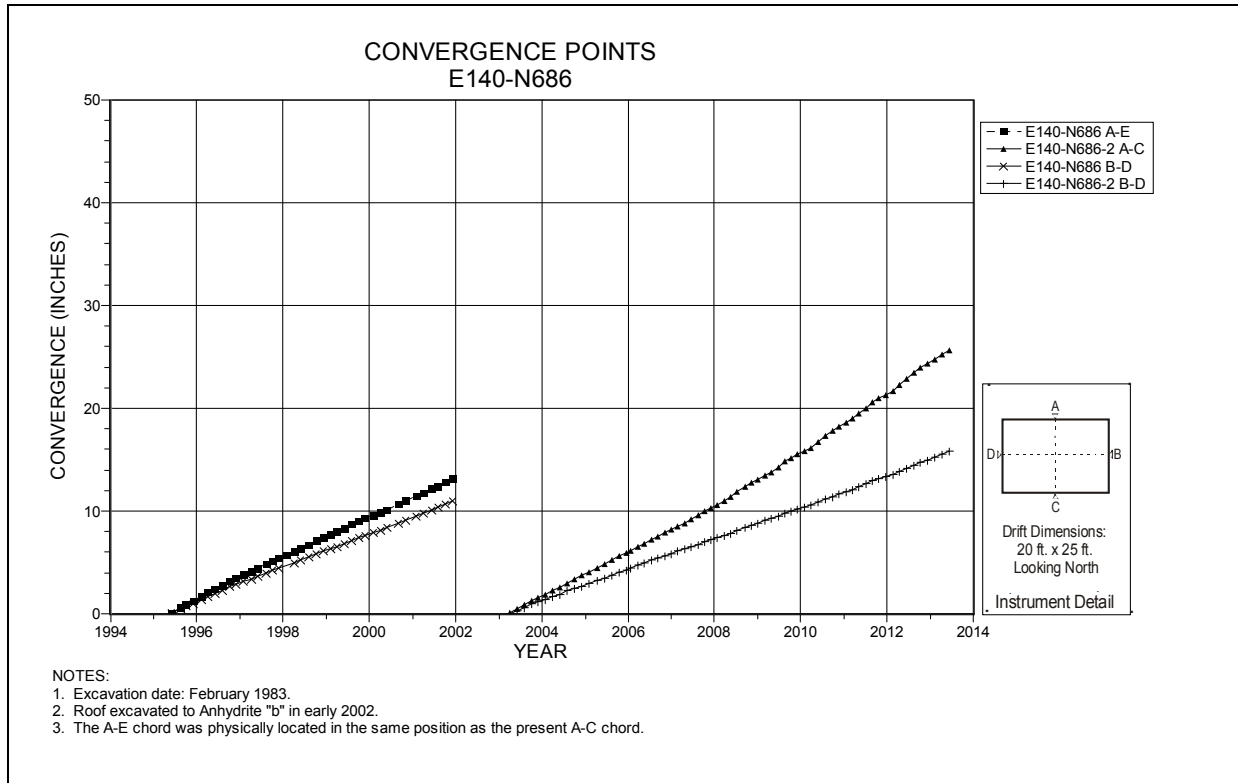

**Figure 4-55 Convergence Point Array
E140 N686 – All Chords**

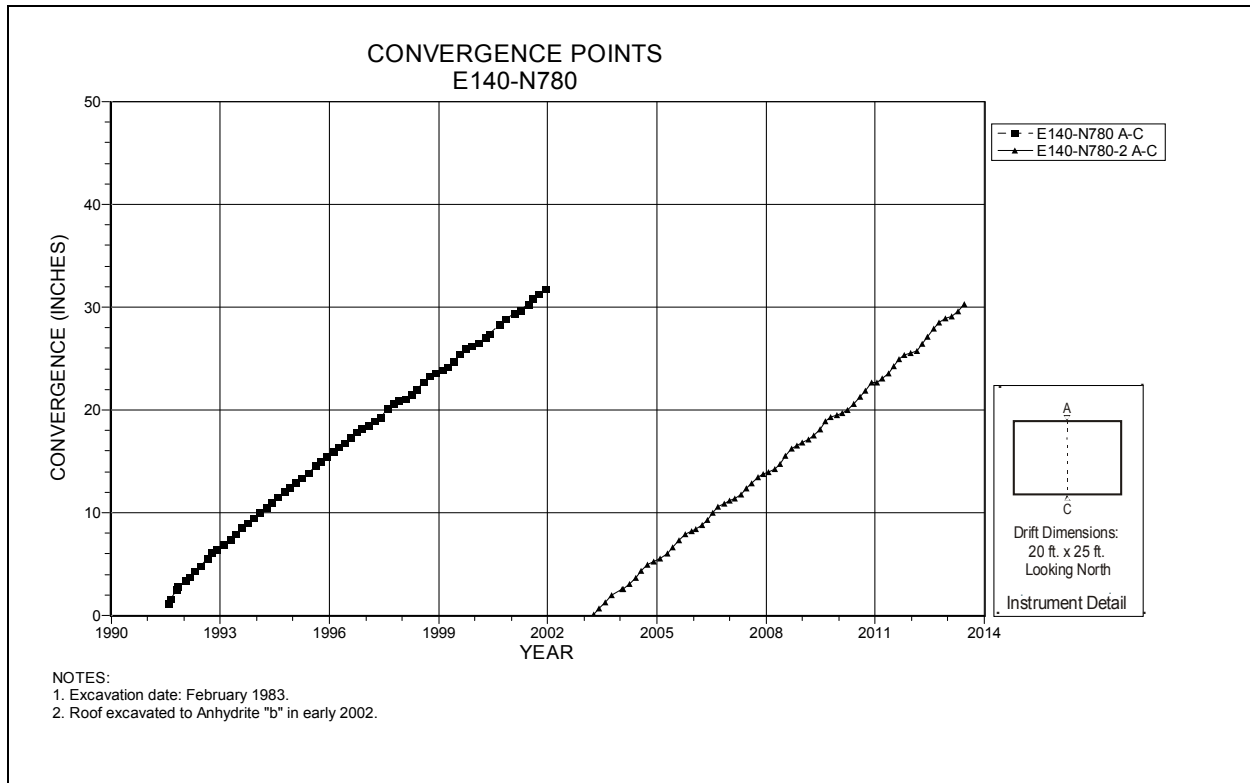

**Figure 4-56 Convergence Point Array
E140 N780 – Roof to Floor**

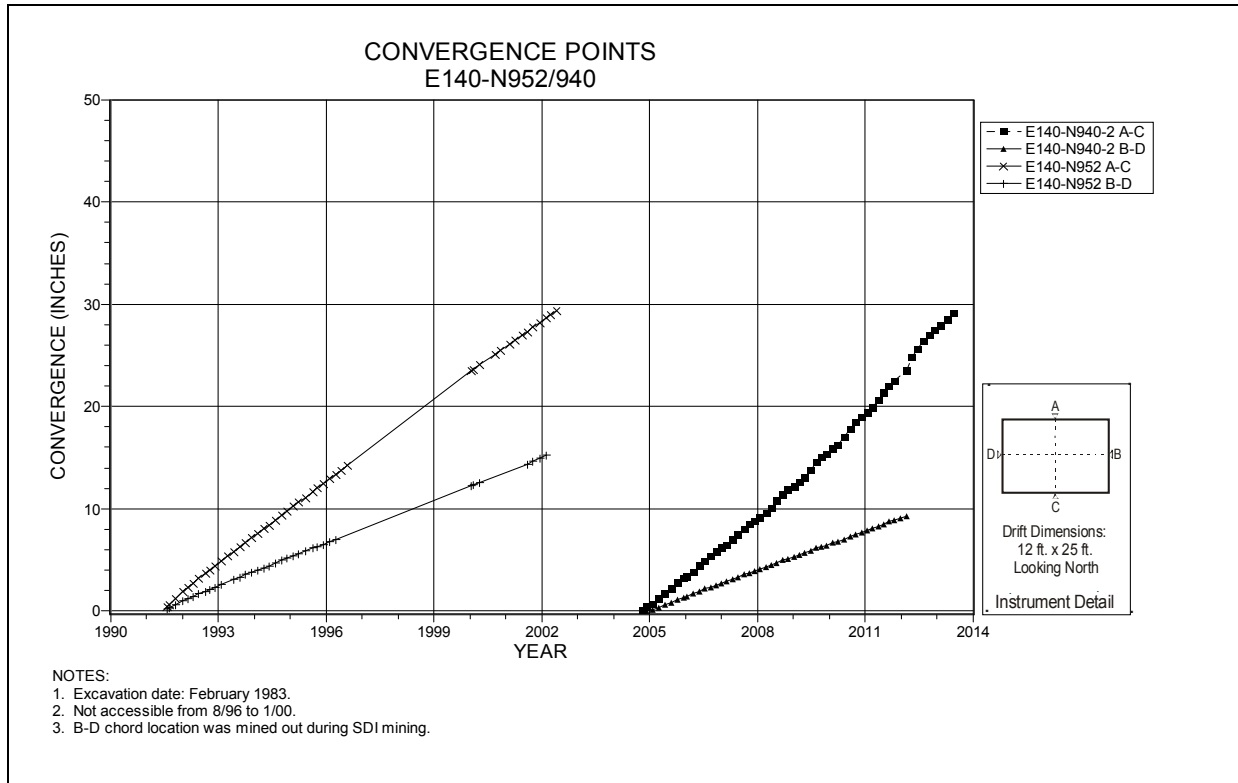

**Figure 4-57 Convergence Point Array
E140 N940/N952 – All Chords**

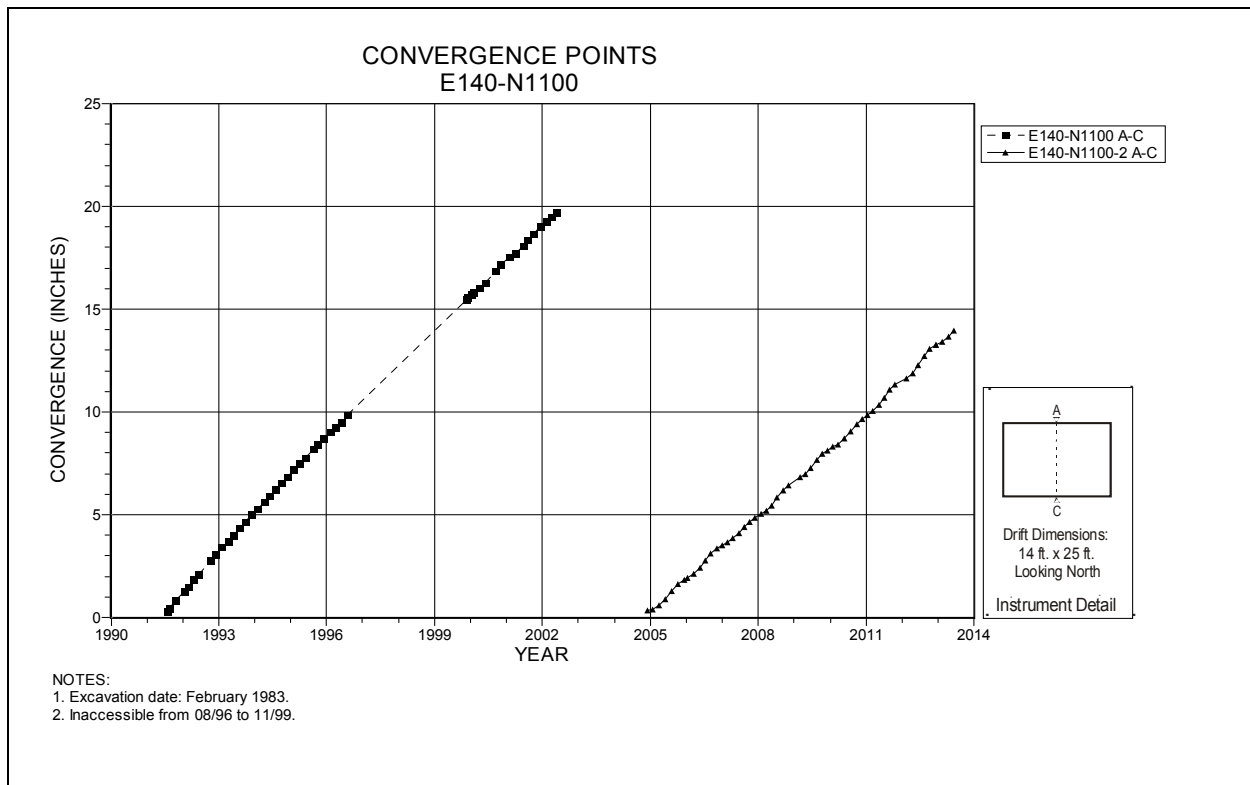

**Figure 4-58 Convergence Point Array
E140 N1100 – Roof to Floor**

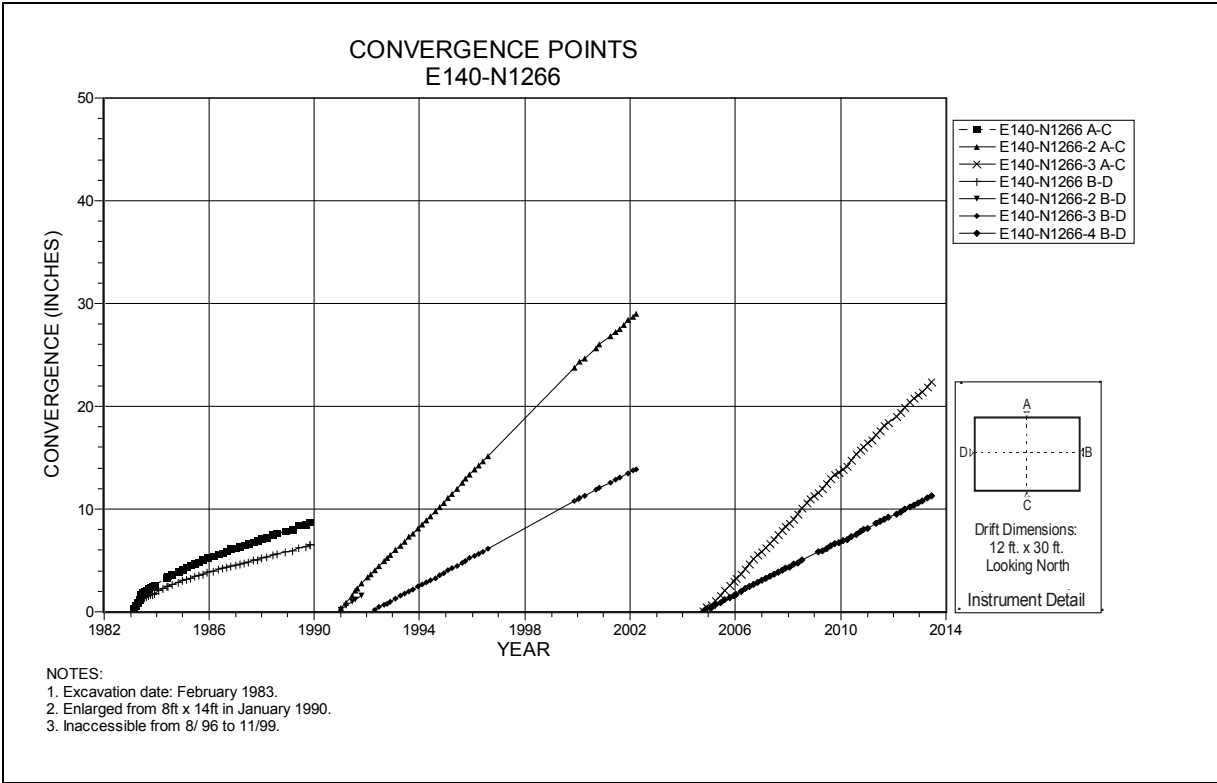

Figure 4-59 Convergence Point Array
E140 N1266 – All Chords

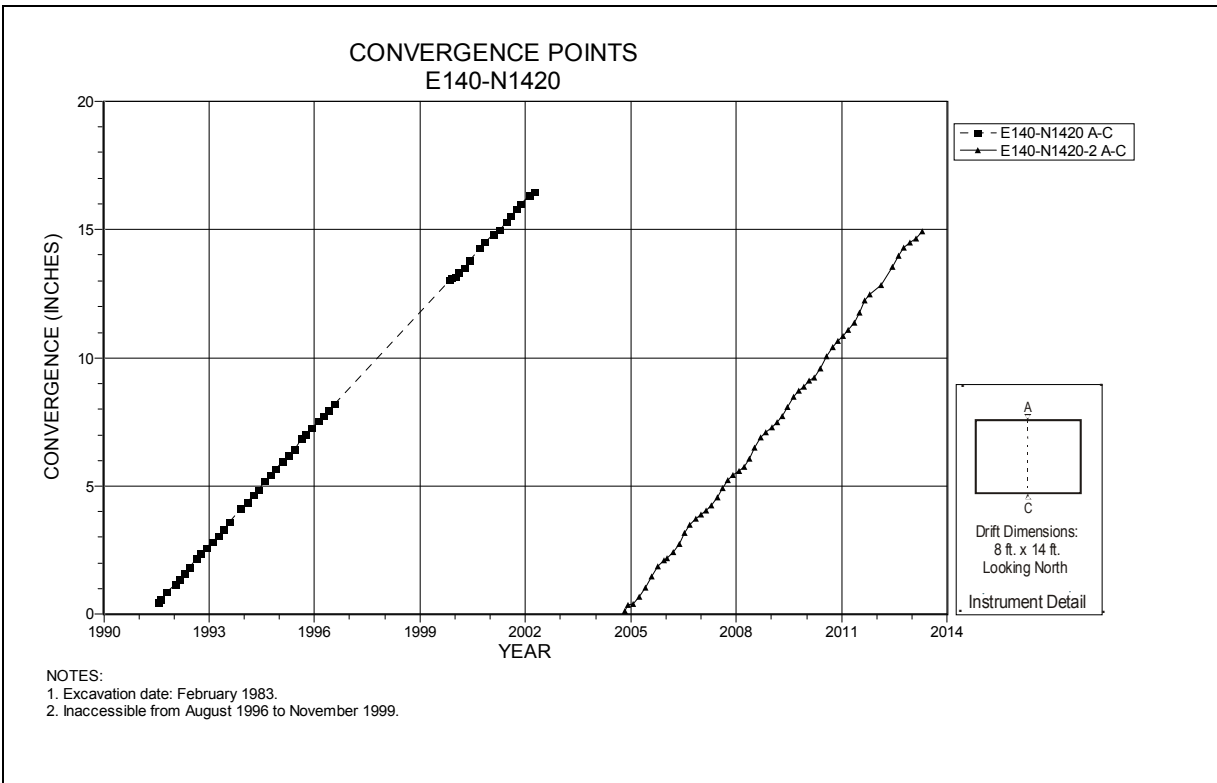

Figure 4-60 Convergence Point Array
E140 N1420 – Roof to Floor

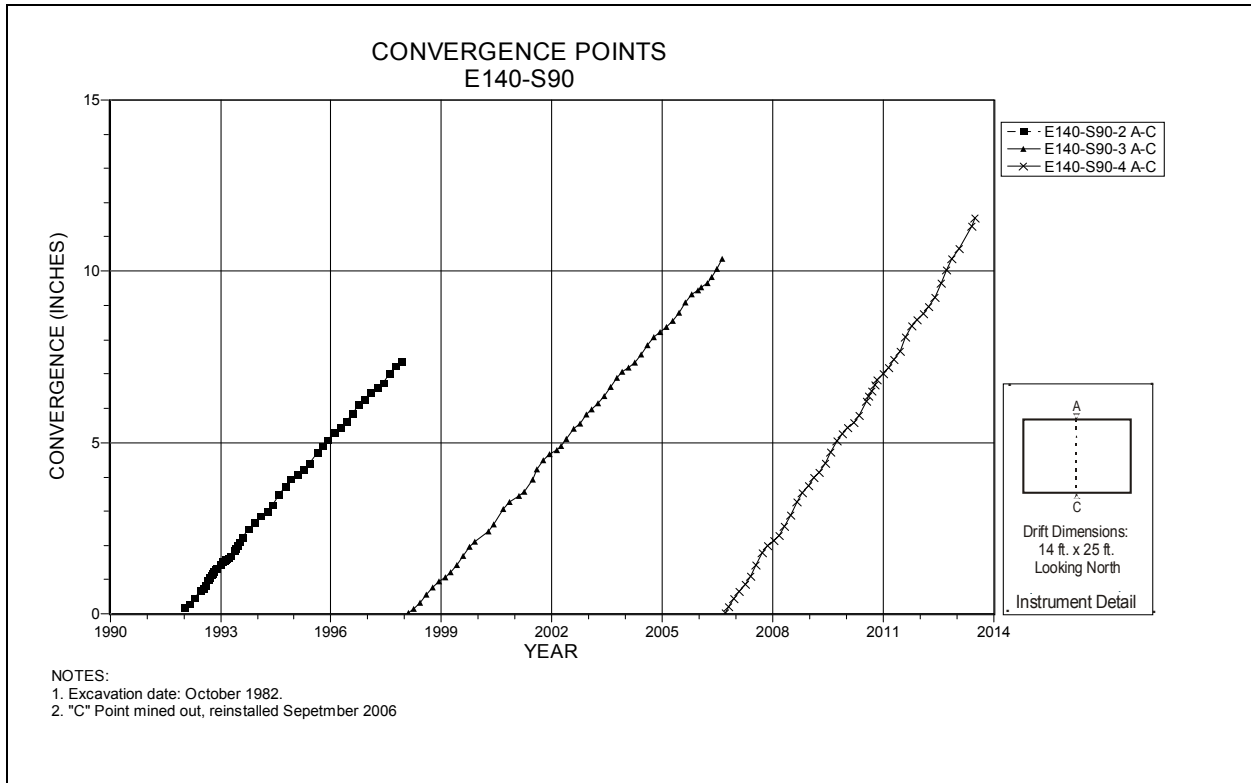

Figure 4-61 Convergence Point Array
E140 S90 – Roof to Floor

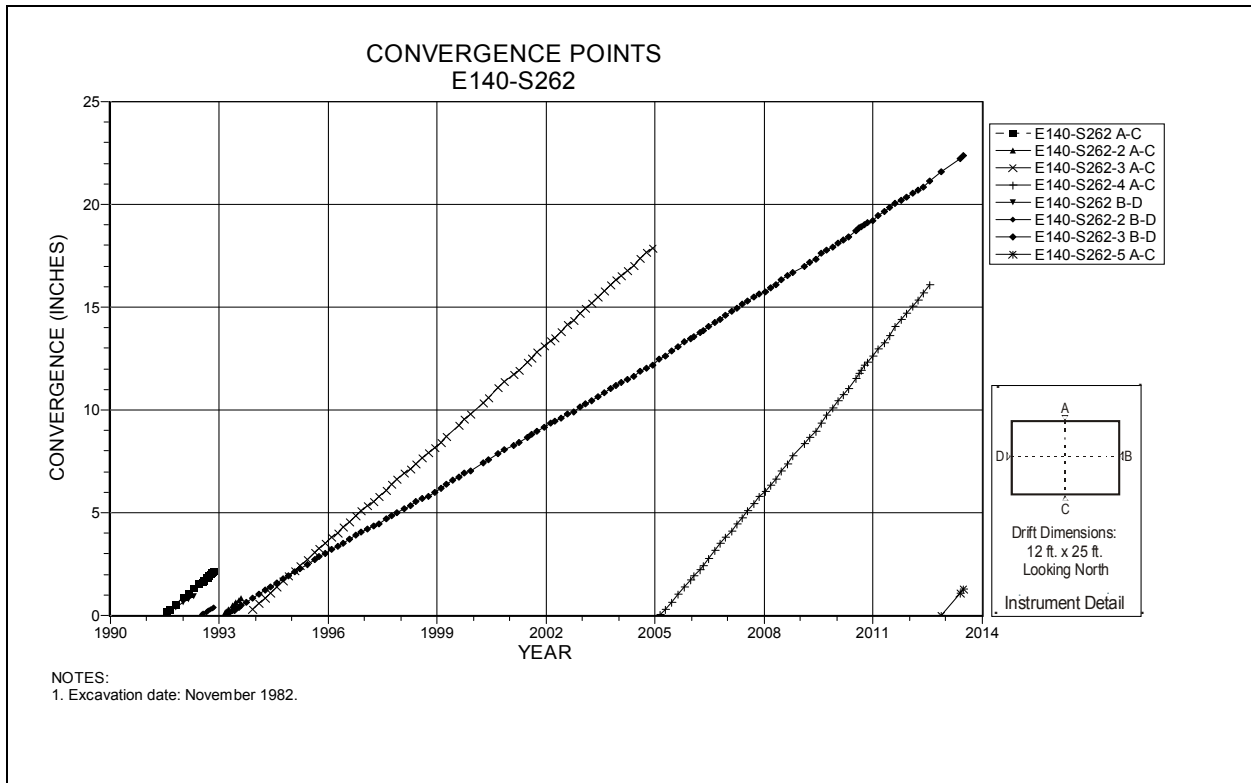

Figure 4-62 Convergence Point Array
E140 S262 – All Chords

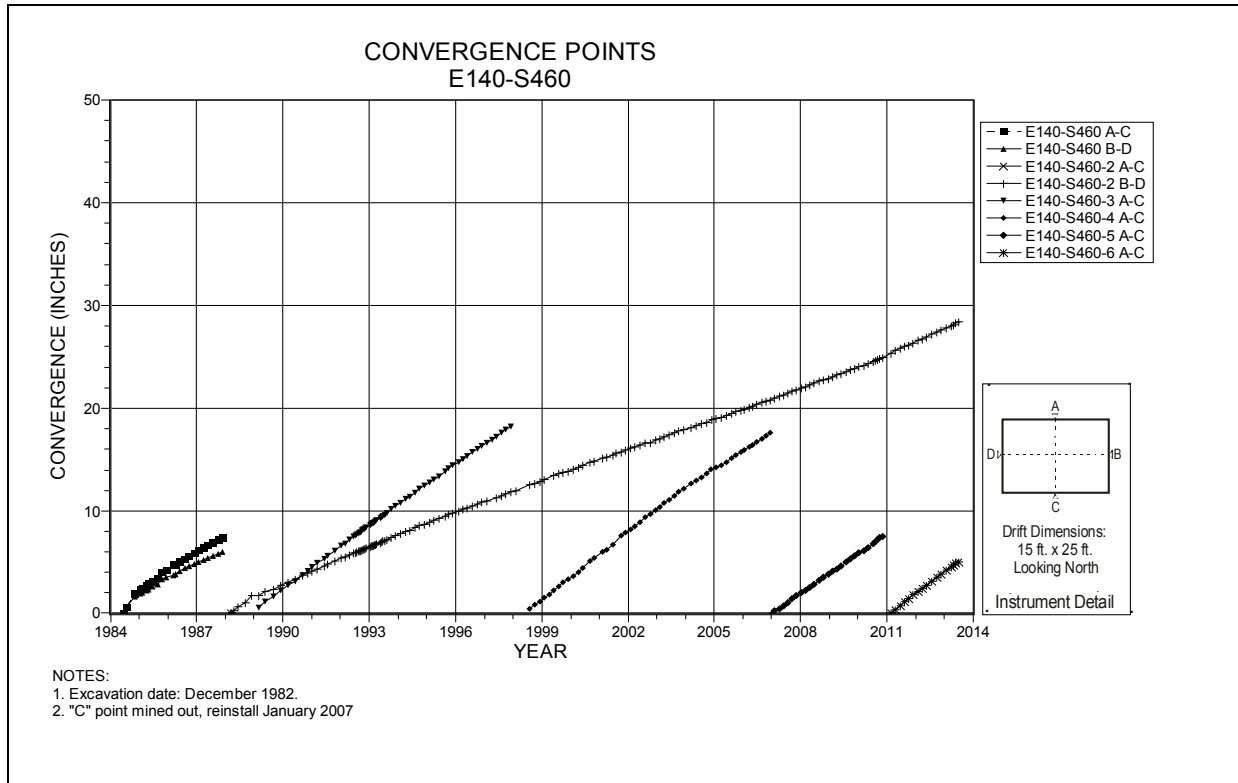

Figure 4-63 Convergence Point Array
E140 S460 – All Chords

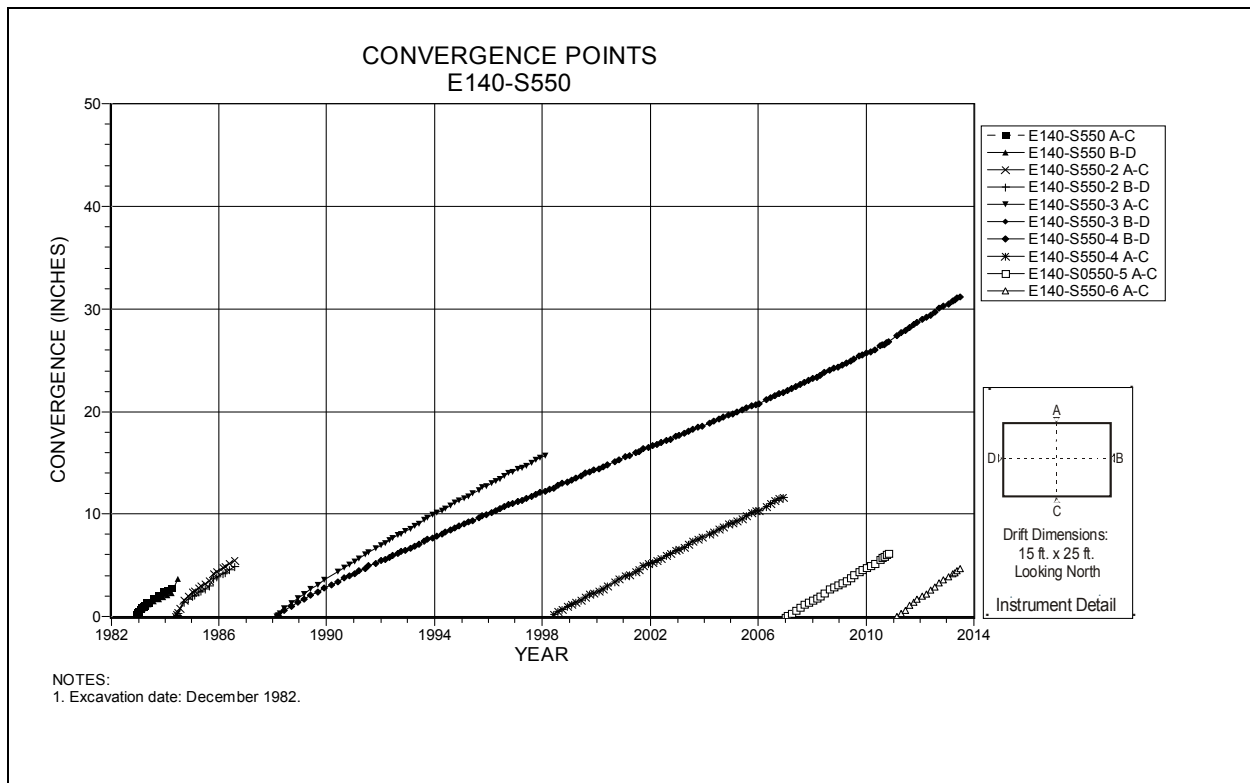
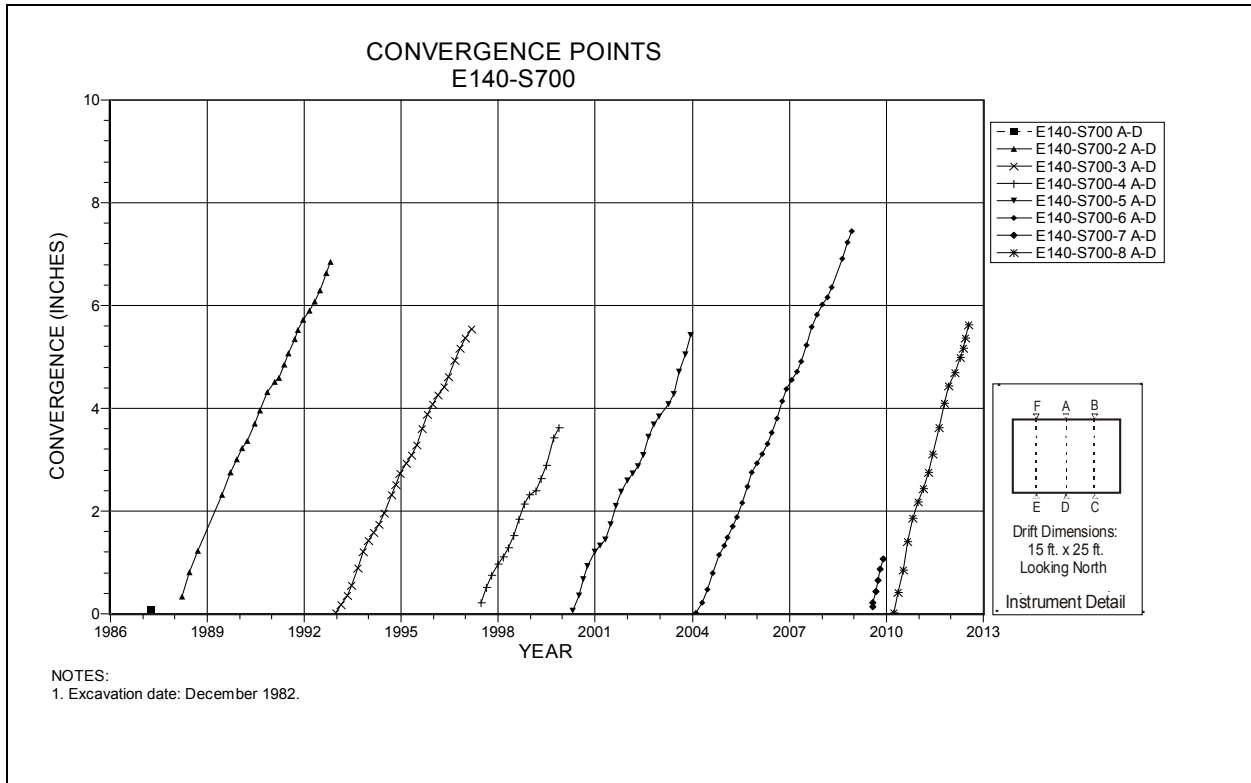
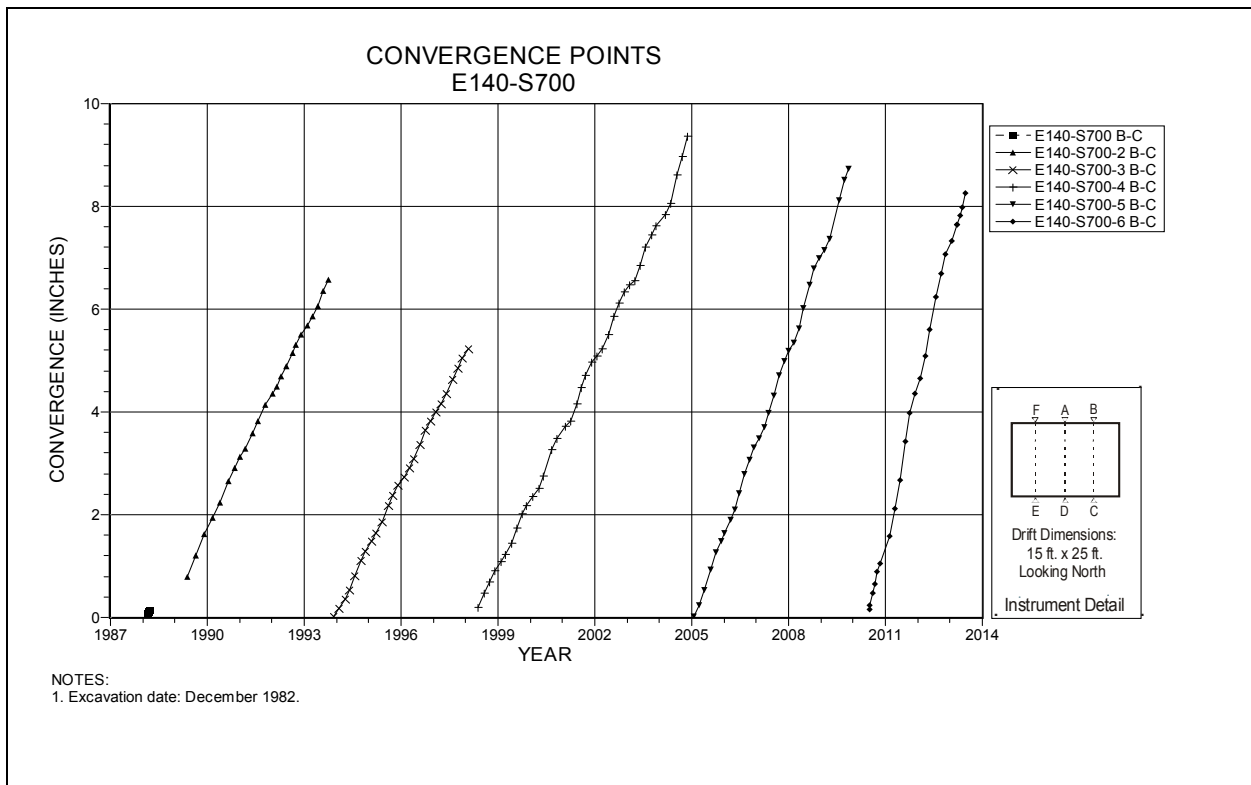

Figure 4-64 Convergence Point Array
E140 S550 – All Chords



**Figure 4-65 Convergence Point Array
E140 S700 – Roof to Floor – Centerline**



**Figure 4-66 Convergence Point Array
E140 S700 – Roof to Floor – East Quarter Point**

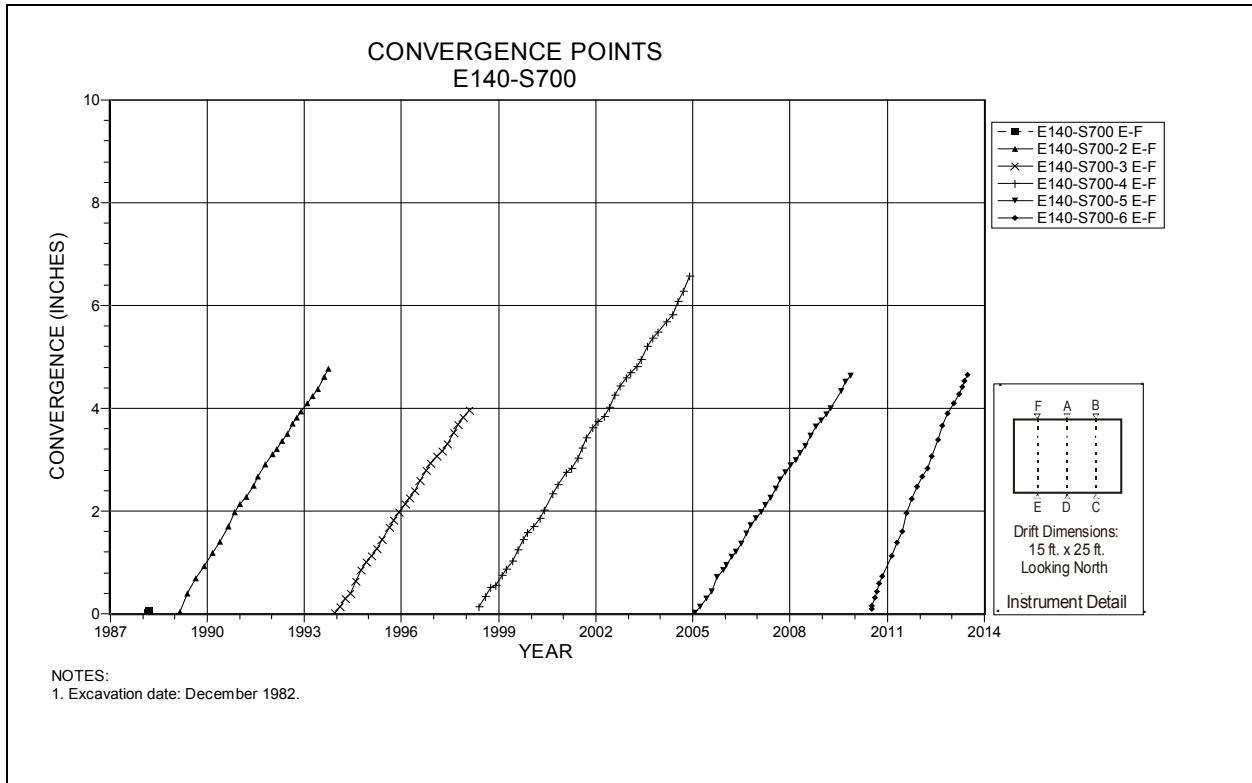

**Figure 4-67 Convergence Point Array
E140 S700 – Roof to Floor – West Quarter Point**

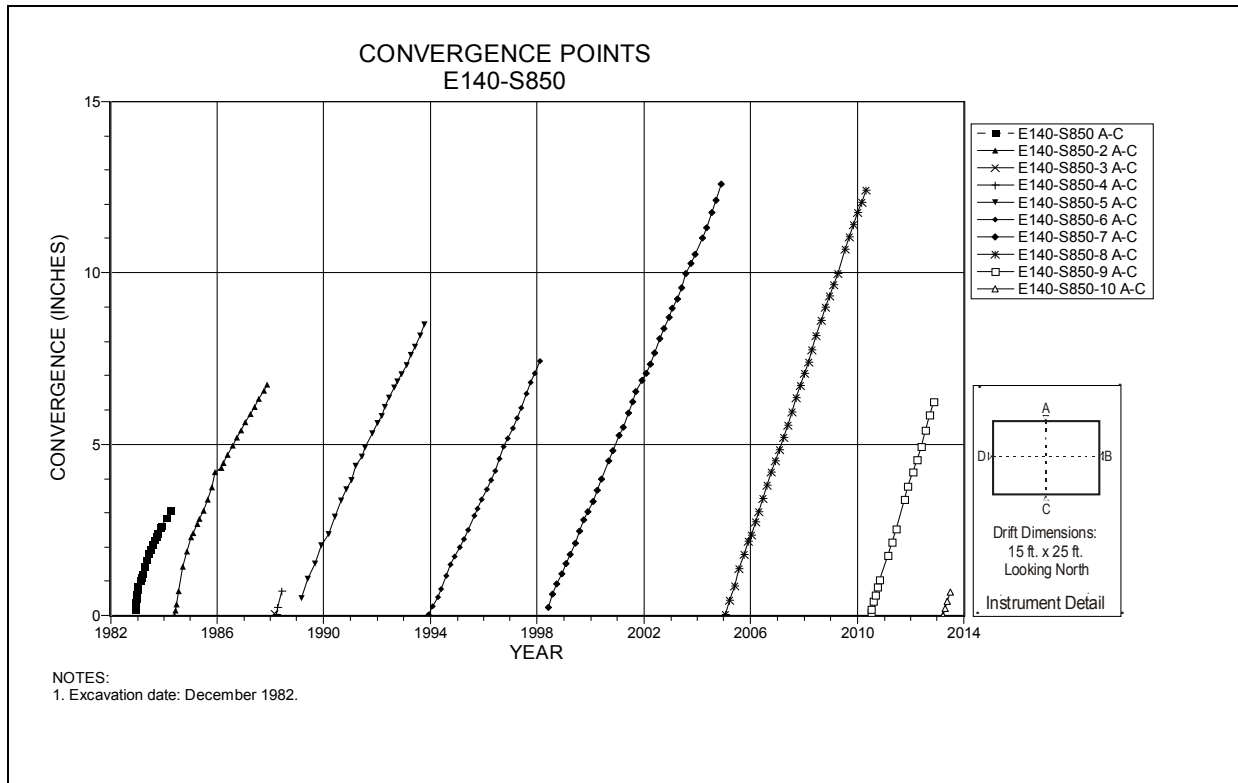

**Figure 4-68 Convergence Point Array
E140 S850 – Roof to Floor**

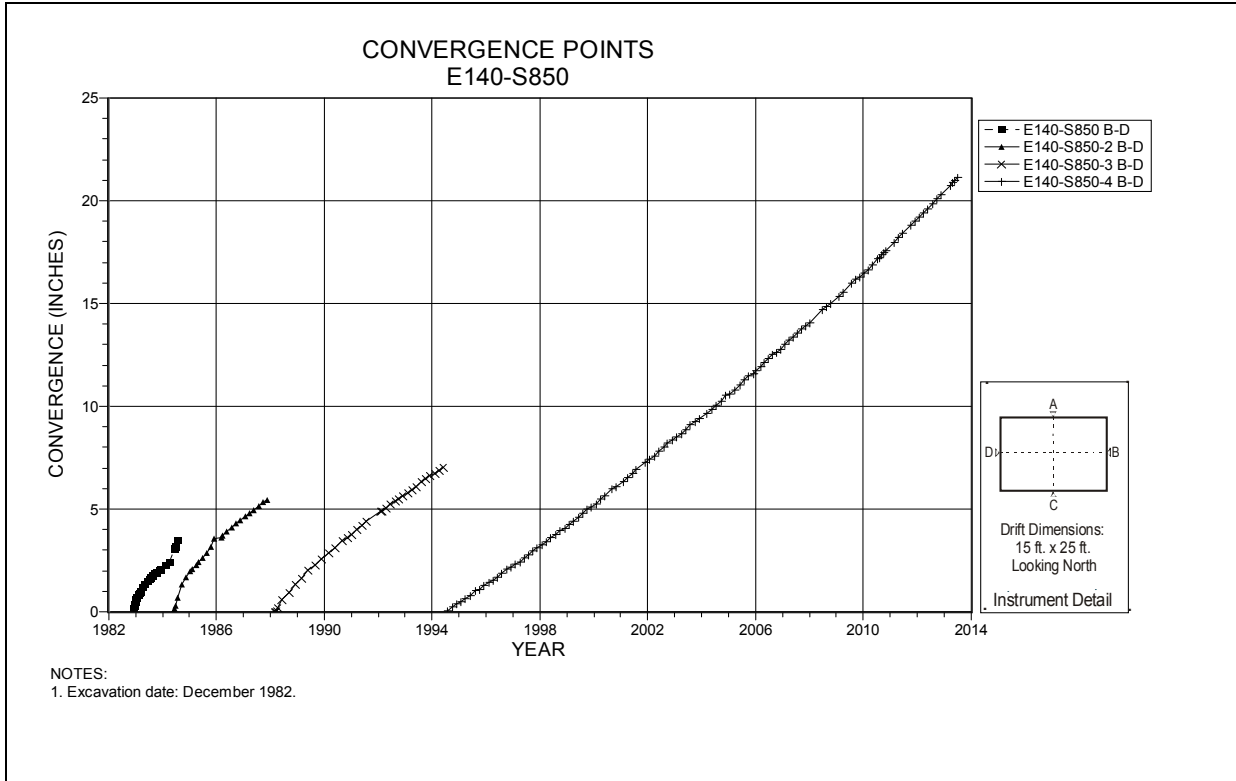

Figure 4-69 Convergence Point Array
E140 S850 – Rib to Rib

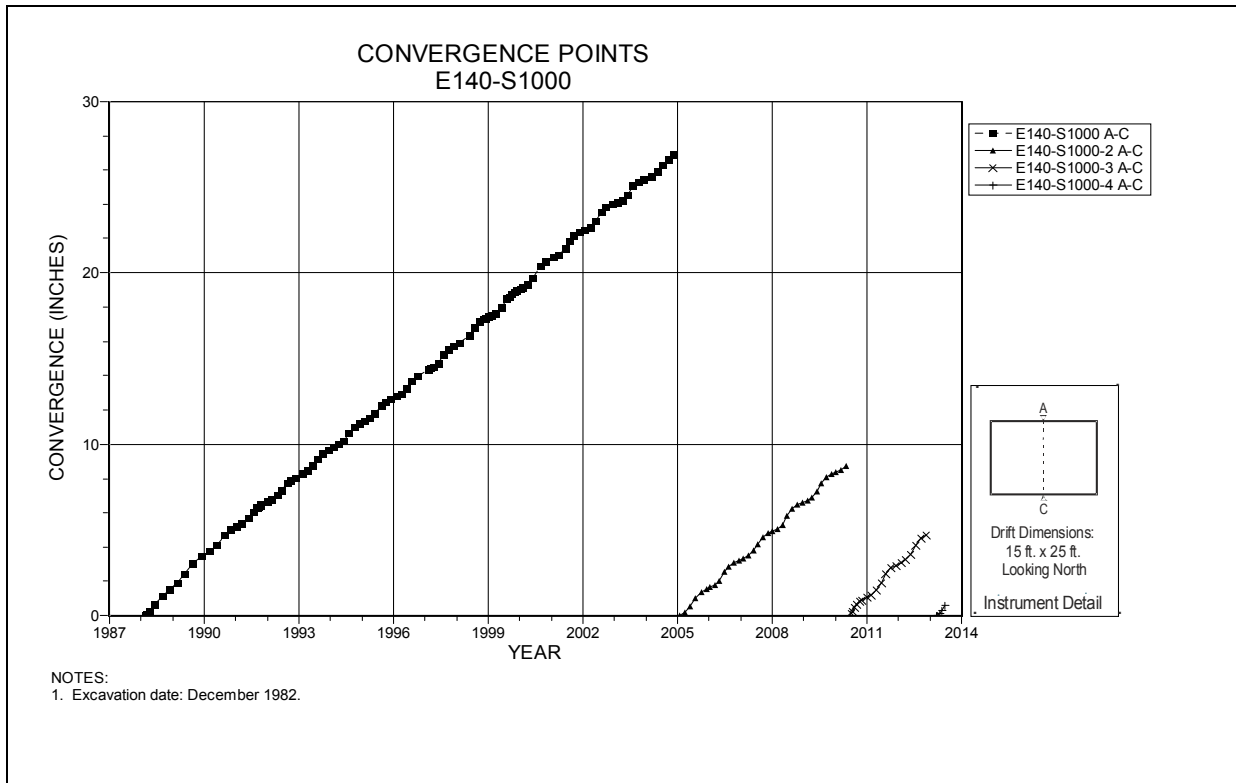
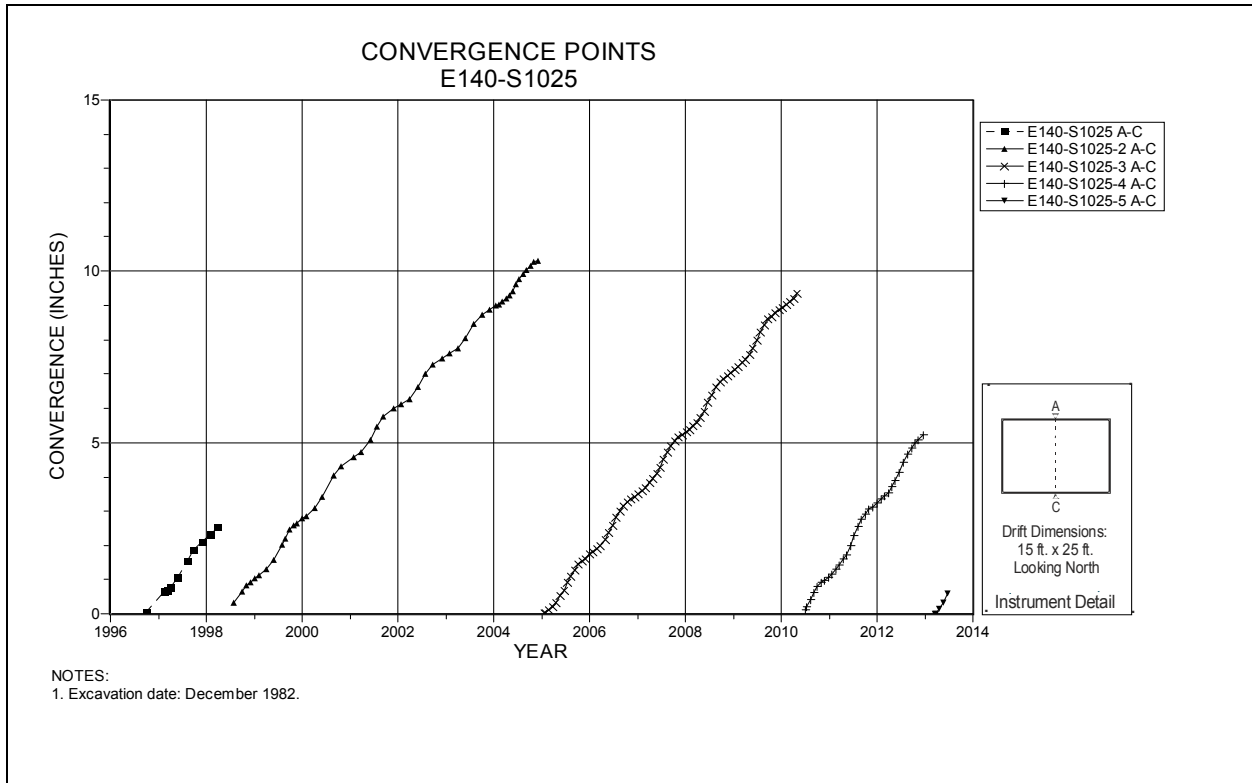
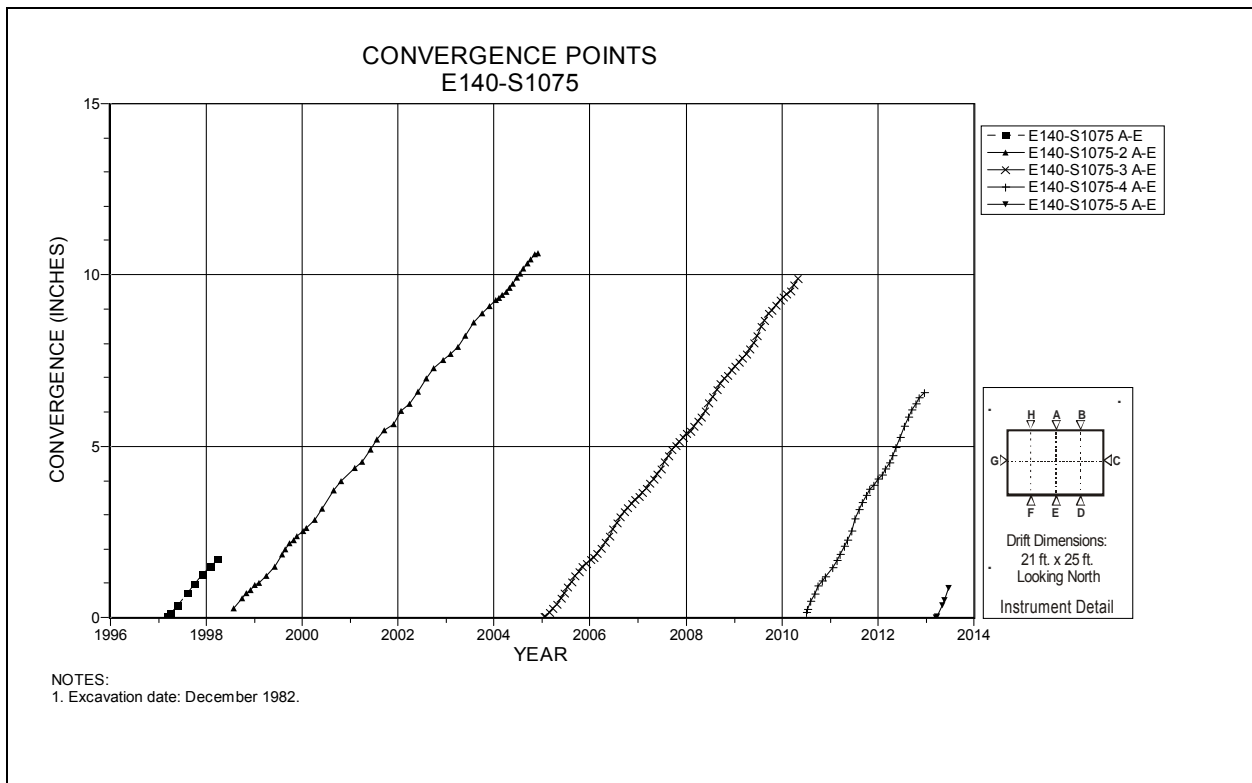

Figure 4-70 Convergence Point Array
E140 S1000 – Roof to Floor



**Figure 4-71 Convergence Point Array
E140 S1025 – Roof to Floor**



**Figure 4-72 Convergence Point Array
E140 S1075 – Roof to Floor – Centerline**

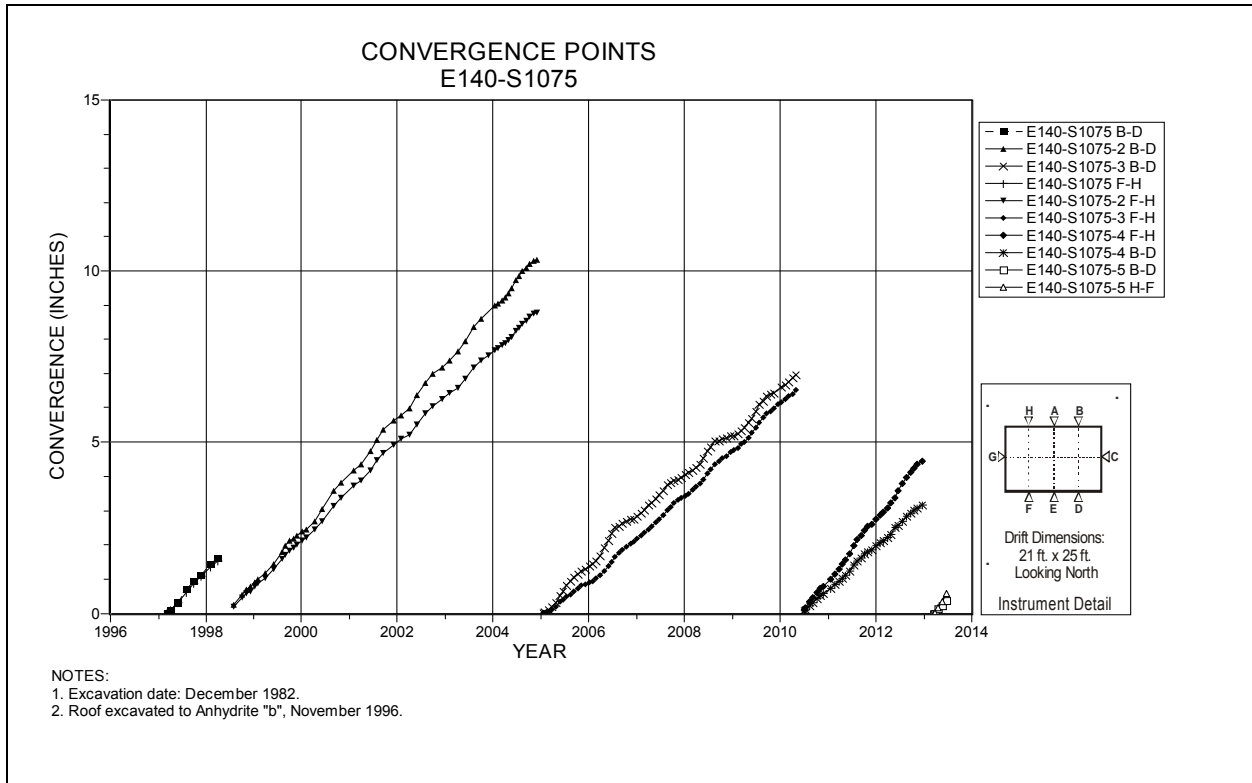

Figure 4-73 Convergence Point Array
E140 S1075 – Roof to Floor – Quarter Points

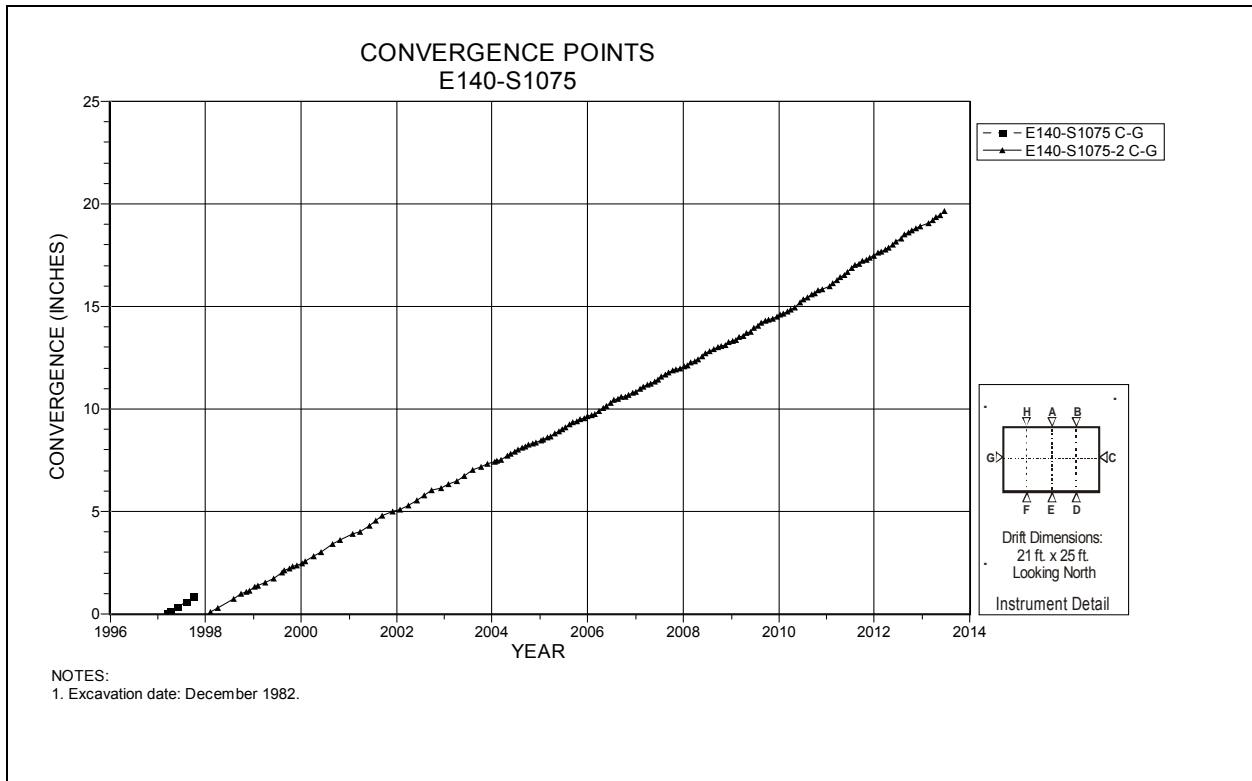
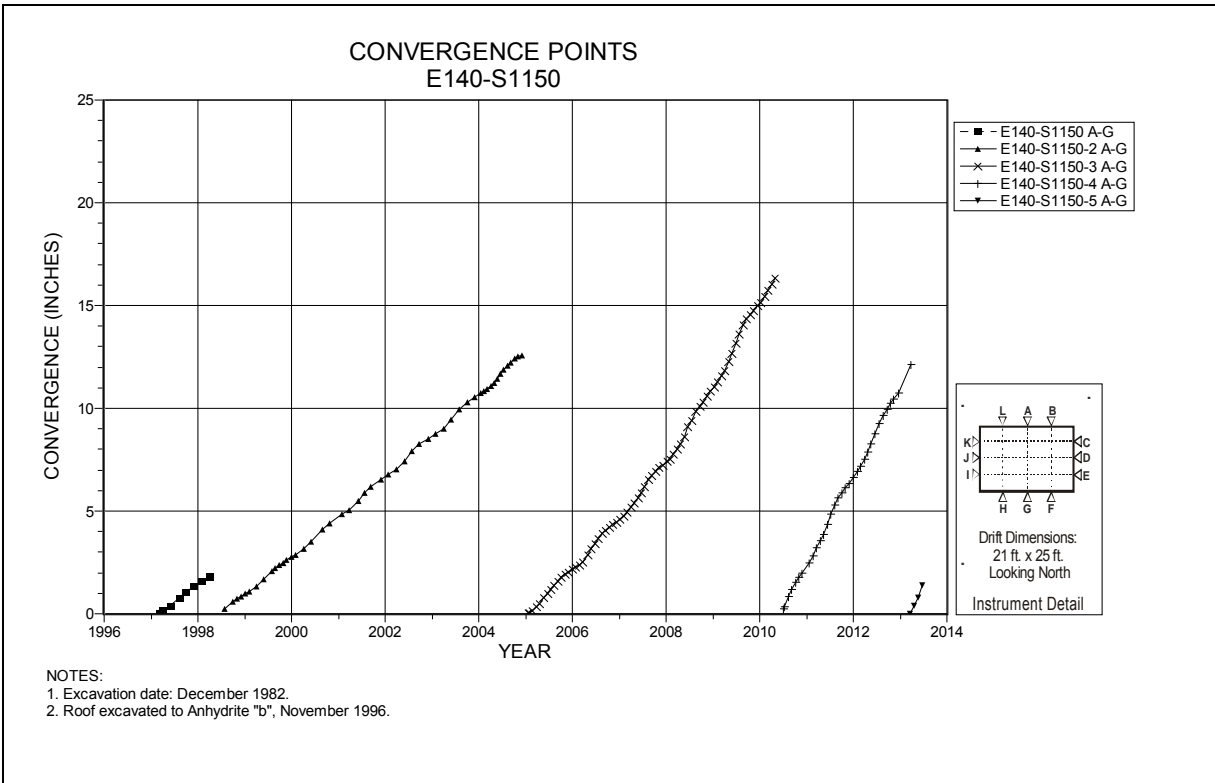
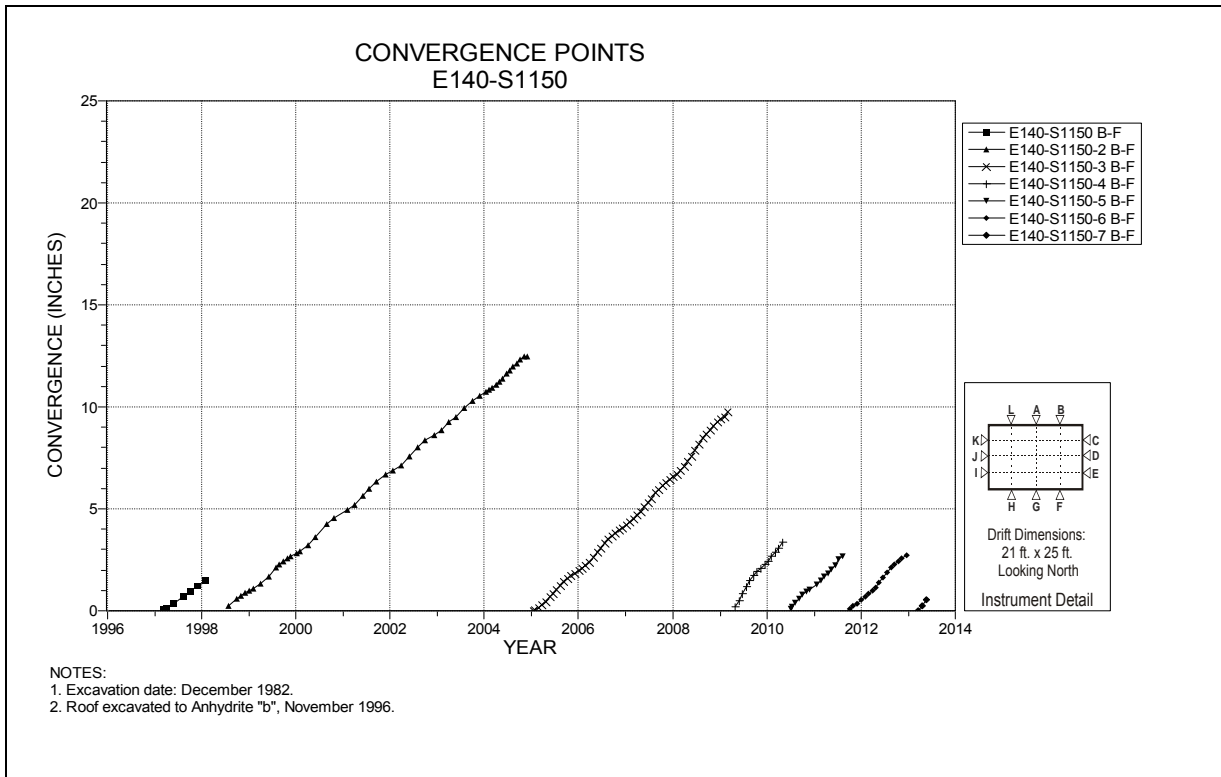

Figure 4-74 Convergence Point Array
E140 S1075 – Rib to Rib



**Figure 4-75 Convergence Point Array
E140 S1150 – Roof to Floor – Centerline**



**Figure 4-76 Convergence Point Array
E140 S1150 – Roof to Floor – East Quarter Point**

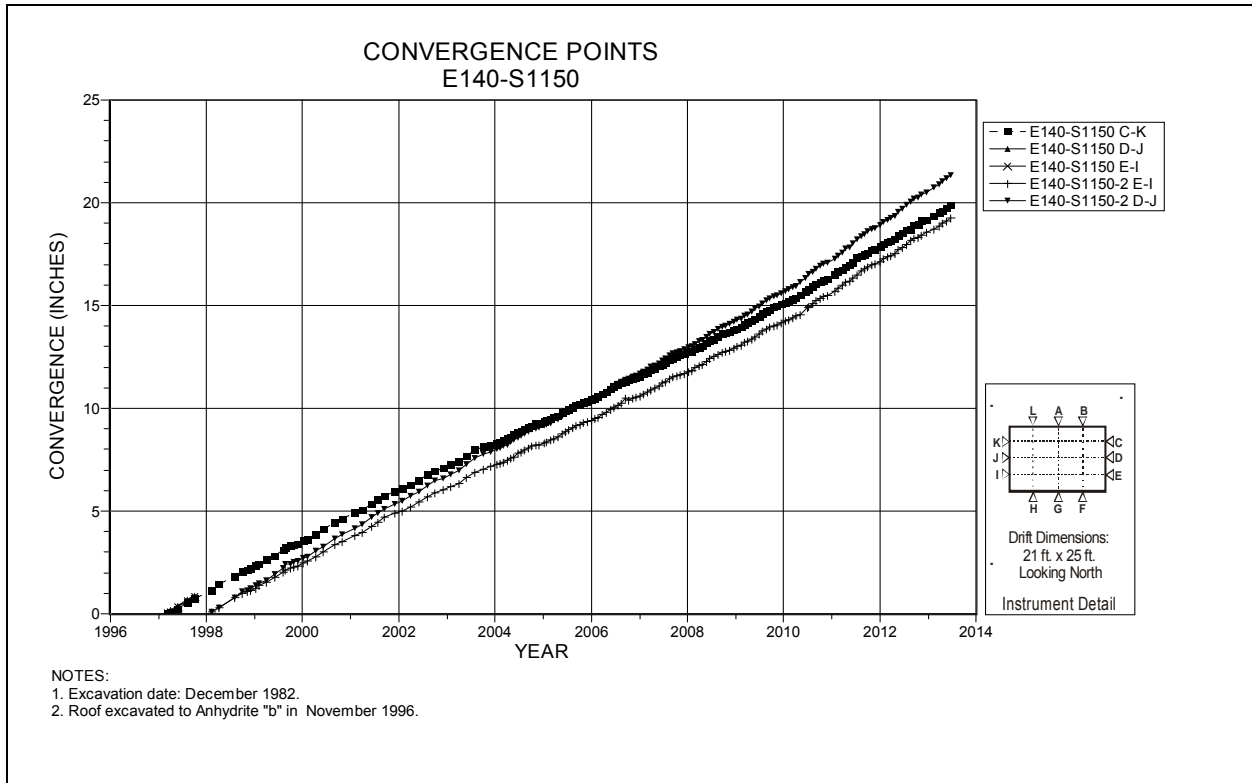

**Figure 4-77 Convergence Point Array
E140 S1150 – Rib to Rib**

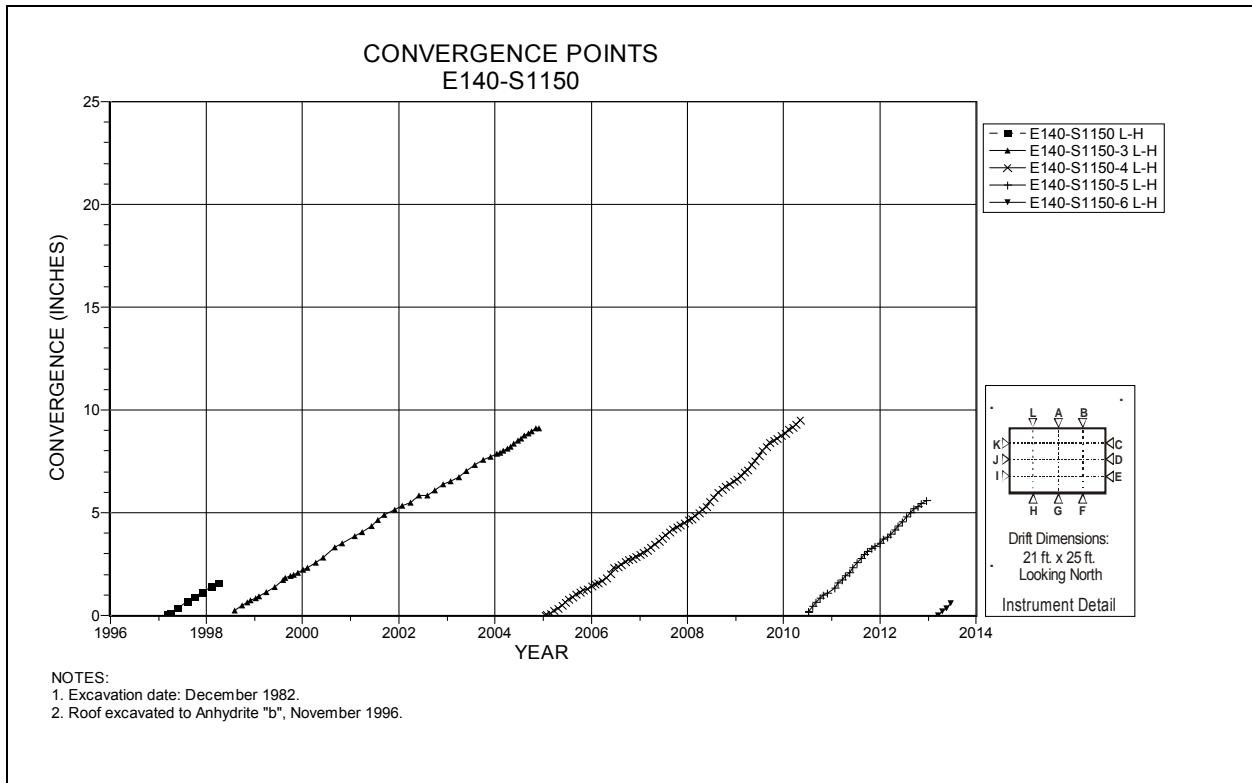

**Figure 4-78 Convergence Point Array
E140 S1150 – Roof to Floor – West Quarter Point**

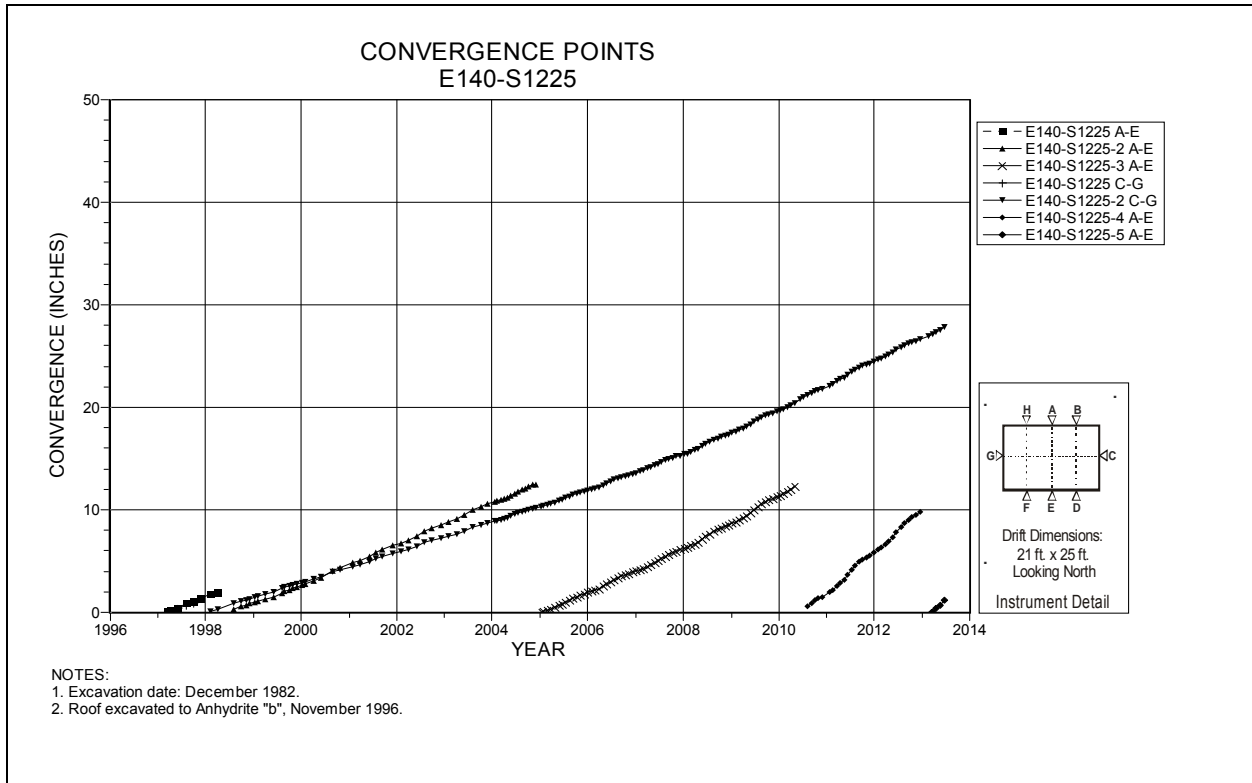

Figure 4-79 Convergence Point Array
E140 S1225 – Roof to Floor – Centerline and Rib to Rib

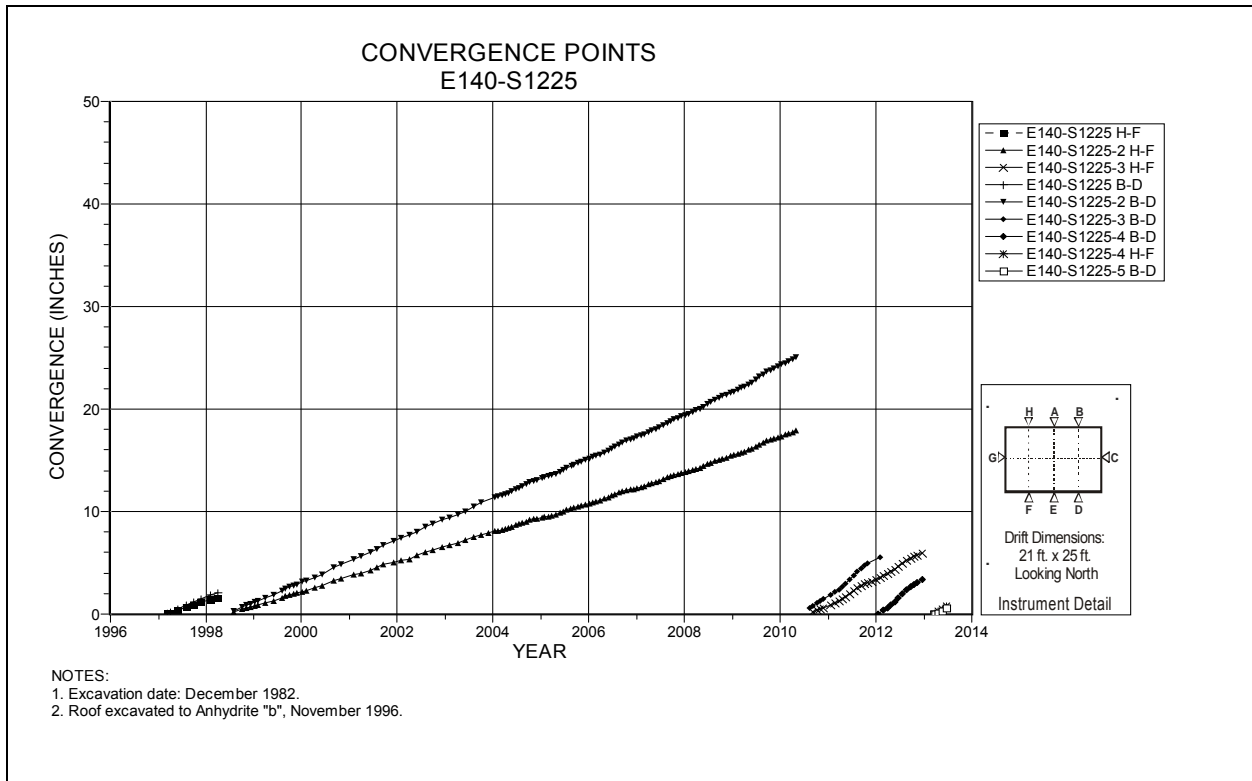

Figure 4-80 Convergence Point Array
E140 S1225 – Roof to Floor – Quarter Points

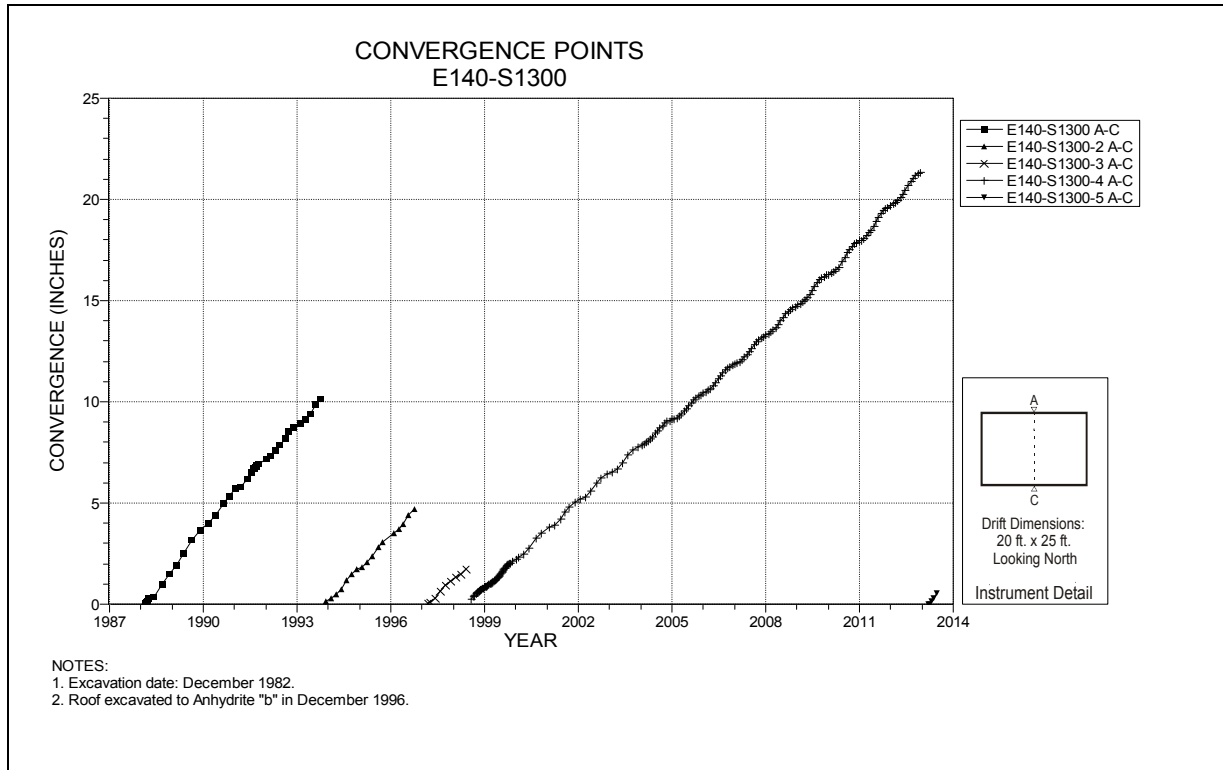

Figure 4-81 Convergence Point Array
E140 S1300 – Roof to Floor

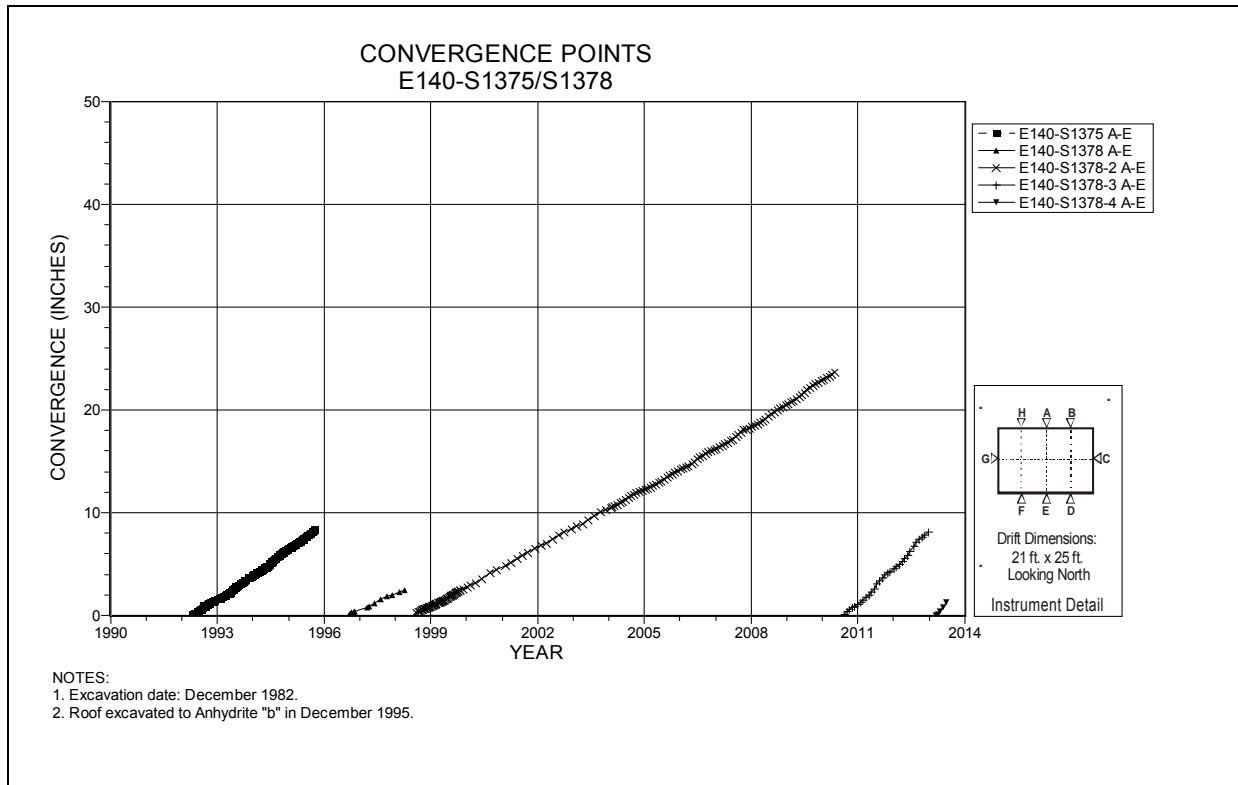

Figure 4-82 Convergence Point Array
E140 S1375/S1378 – Roof to Floor – Centerline

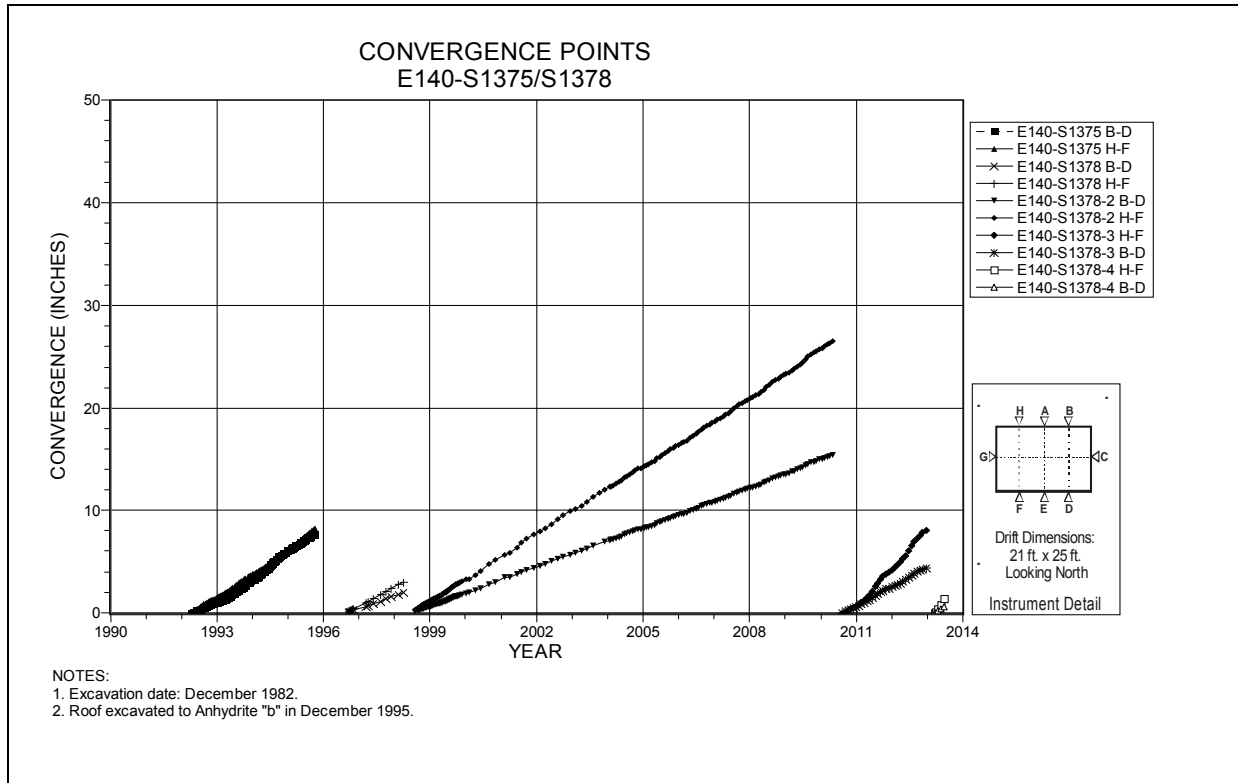

Figure 4-83 Convergence Point Array
E140 S1375/S1378 – Roof to Floor – Quarter Points

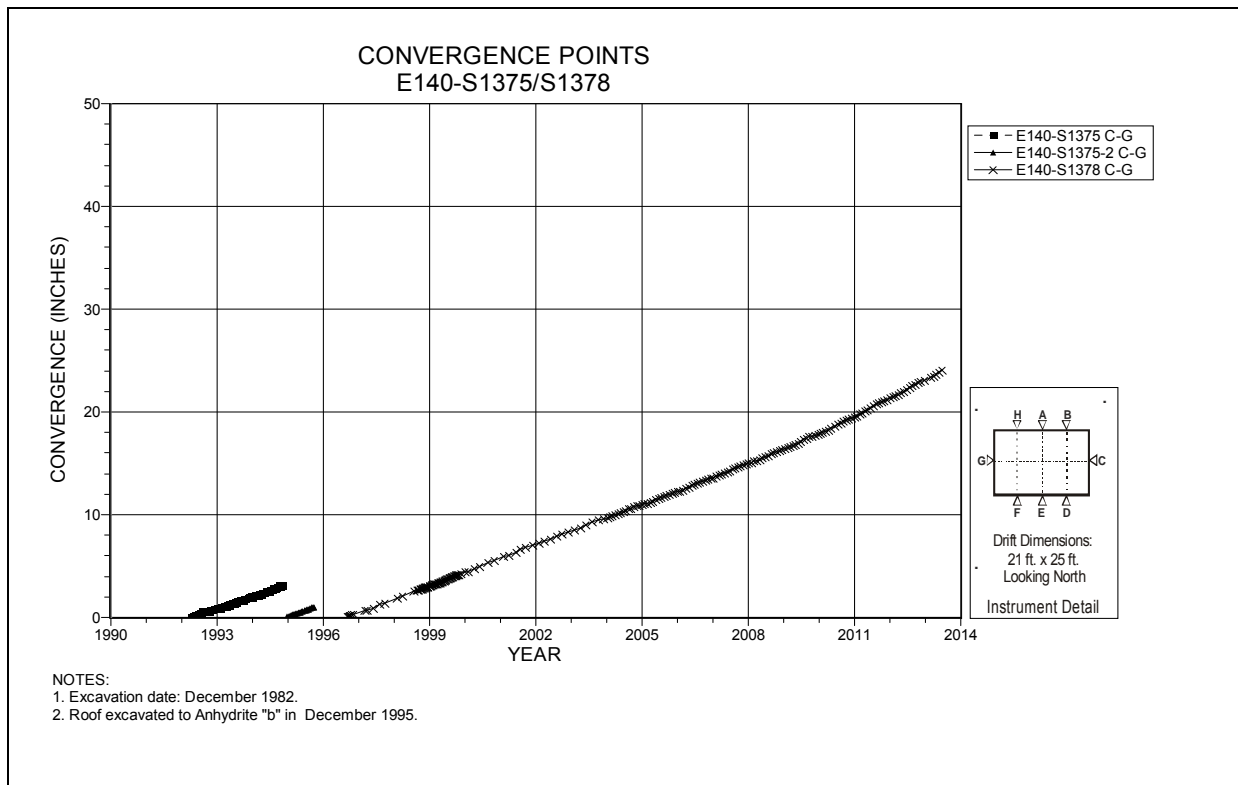

Figure 4-84 Convergence Point Array
E140 S1375/S1378 – Rib to Rib

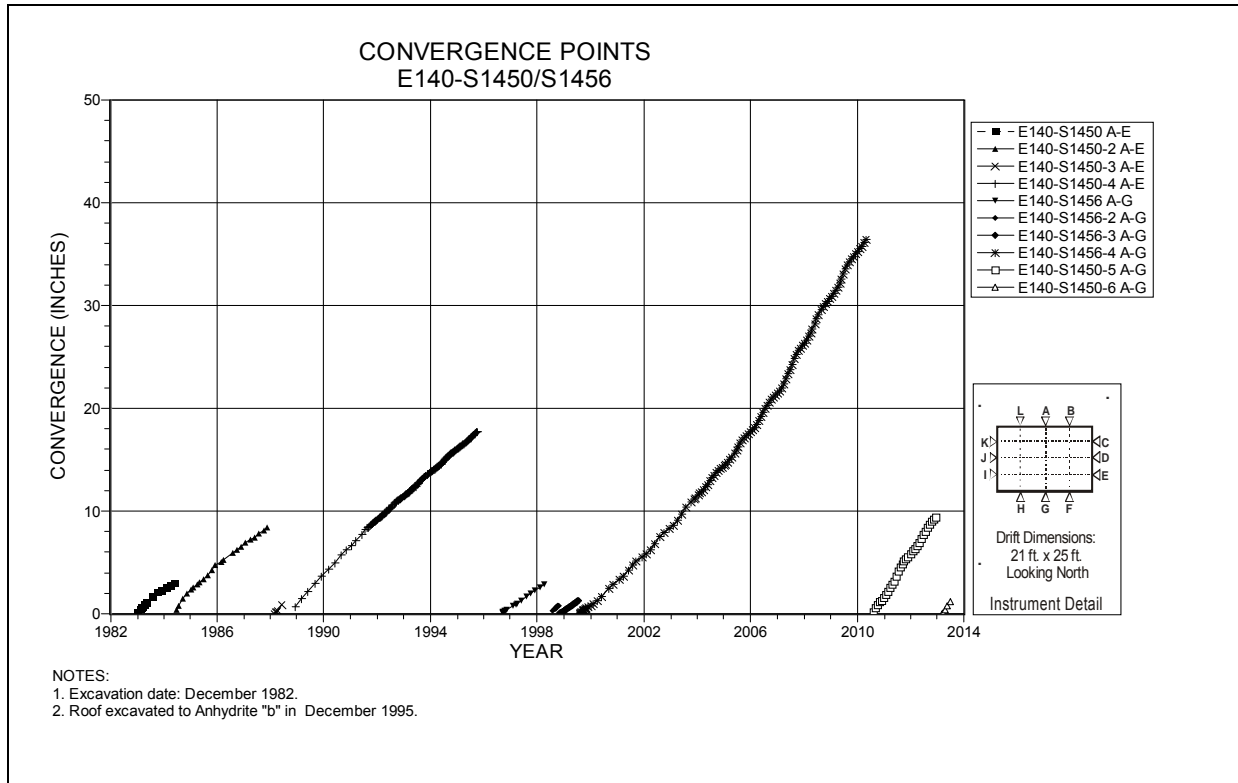

Figure 4-85 Convergence Point Array
E140 S1450/S1456 – Roof to Floor – Centerline

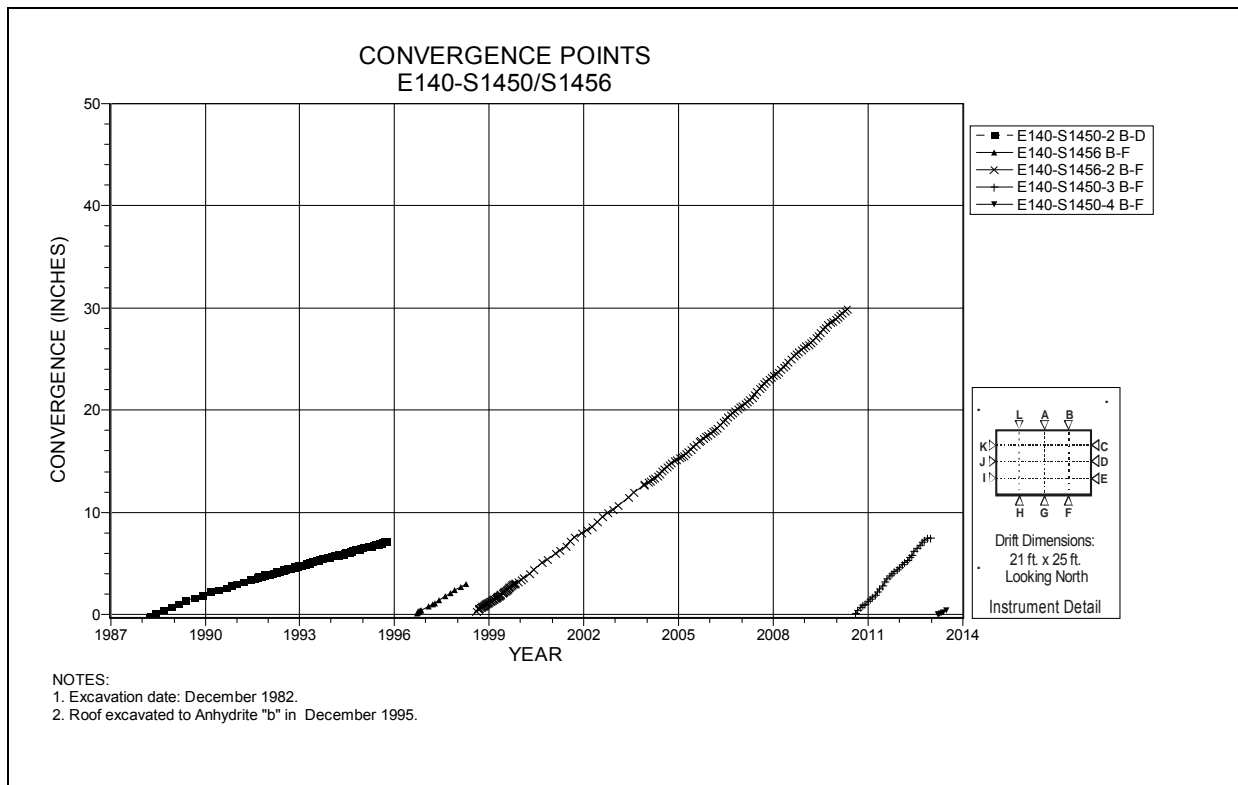

Figure 4-86 Convergence Point Array
E140 S1450/S1456 – Roof to Floor – East Quarter Point

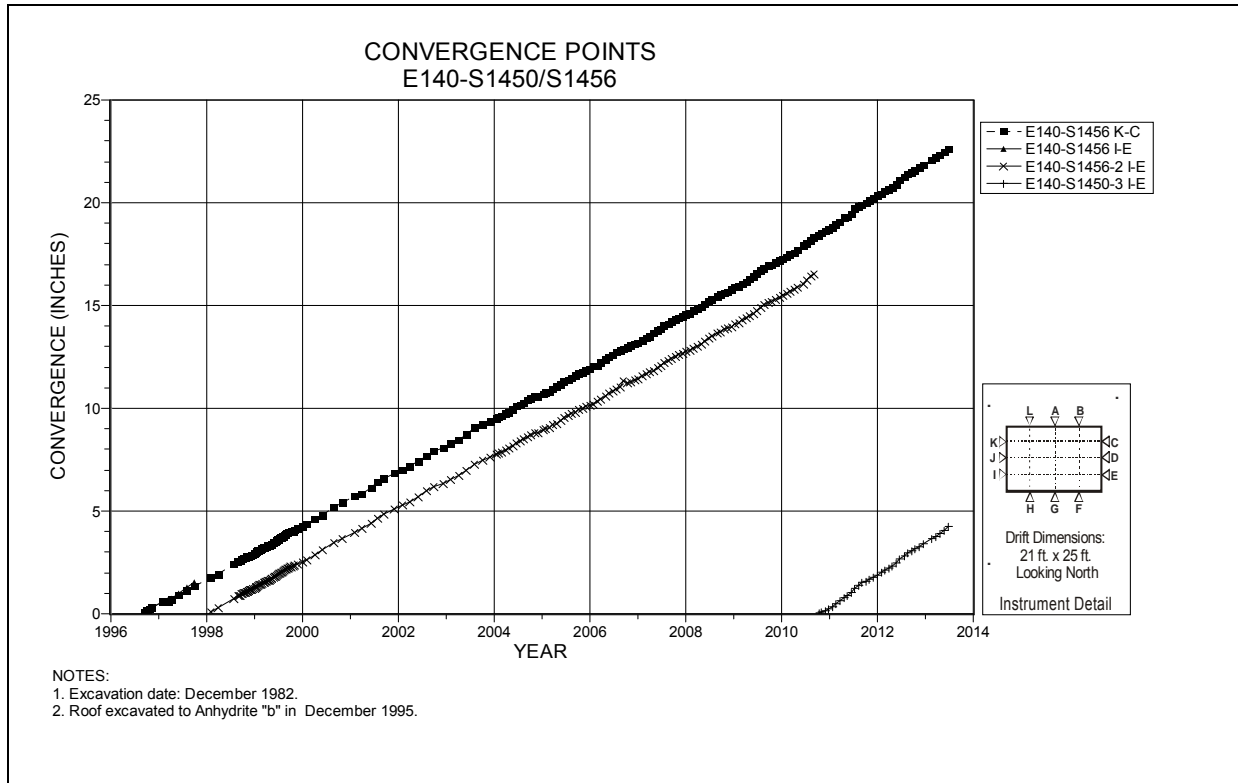

Figure 4-87 Convergence Point Array
E140 S1450/S1456 – Rib to Rib Quarter Points

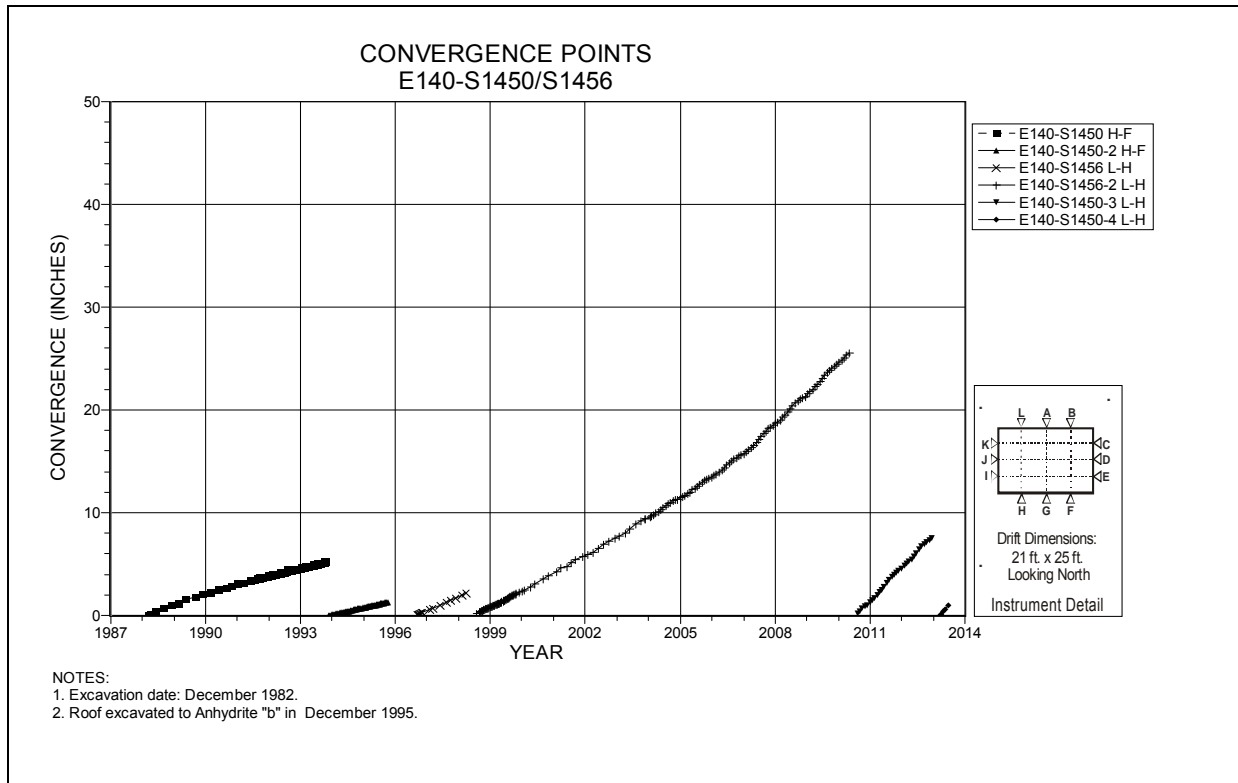

Figure 4-88 Convergence Point Array
E140 S1450/S1456 – Roof to Floor – West Quarter Point

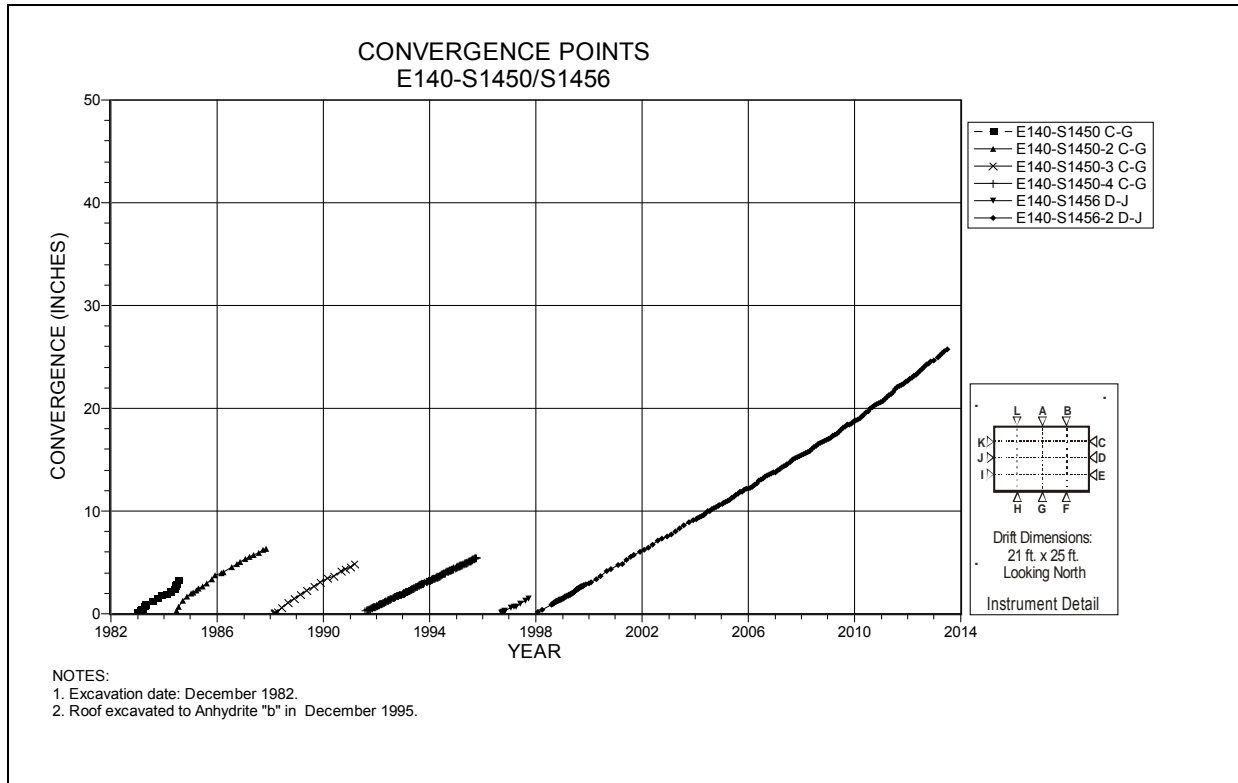

Figure 4-89 Convergence Point Array
E140 S1450/S1456 – Rib to Rib – Mid-Height

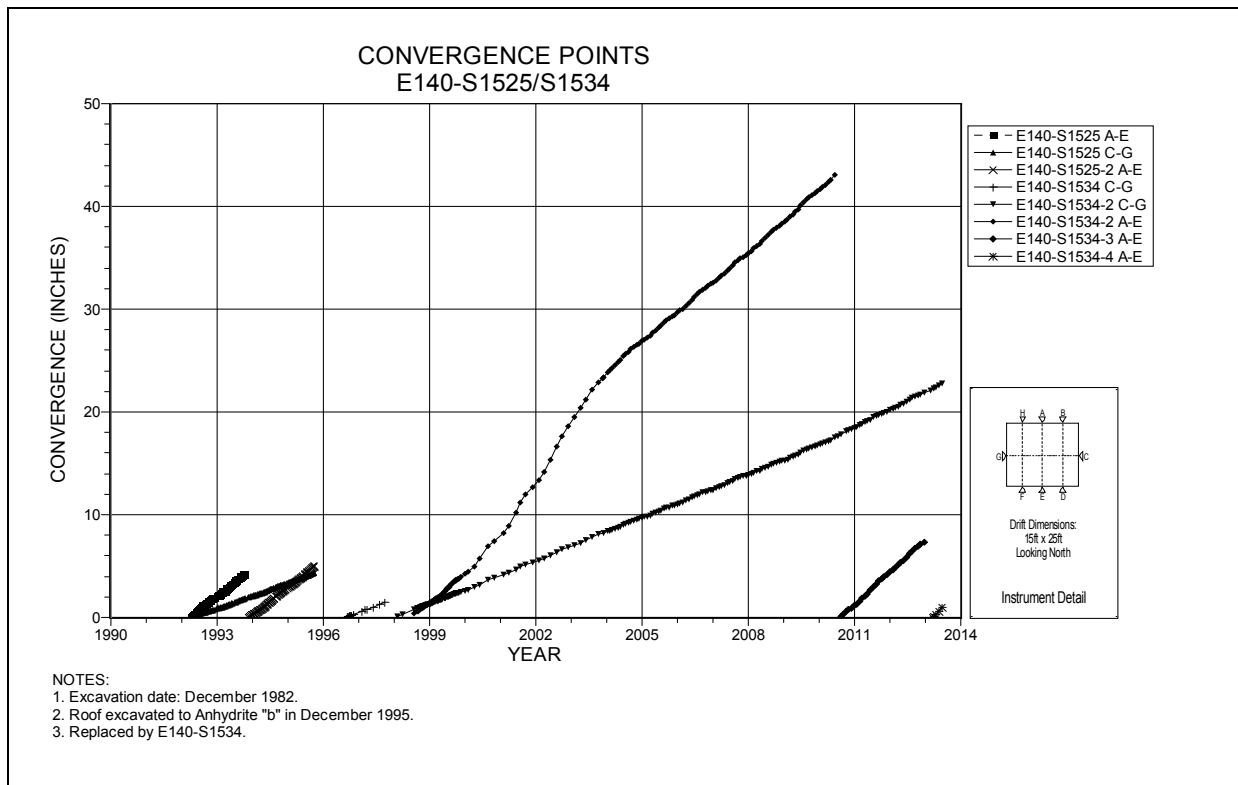

Figure 4-90 Convergence Point Array
E140 S1525/S1534 – Roof to Floor – Centerline and Rib to Rib

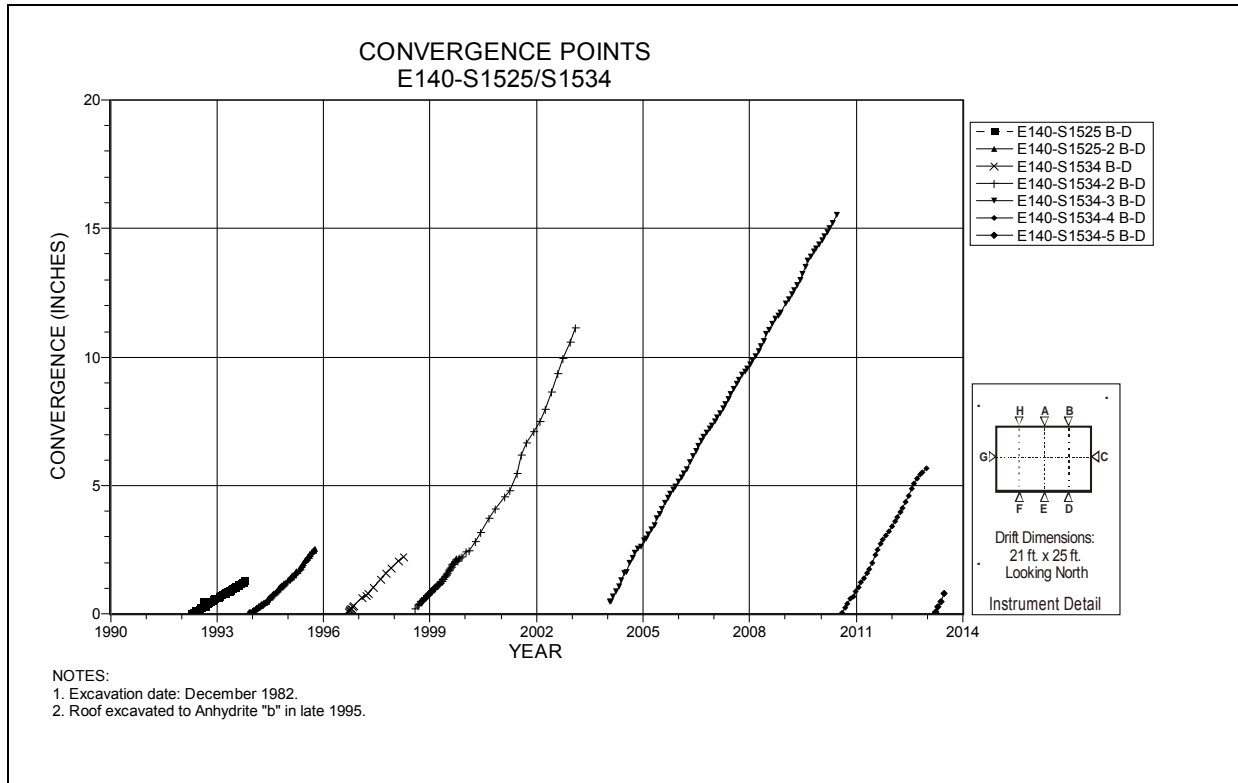

Figure 4-91 Convergence Point Array
E140 S1525/S1534 – Roof to Floor – East Quarter Point

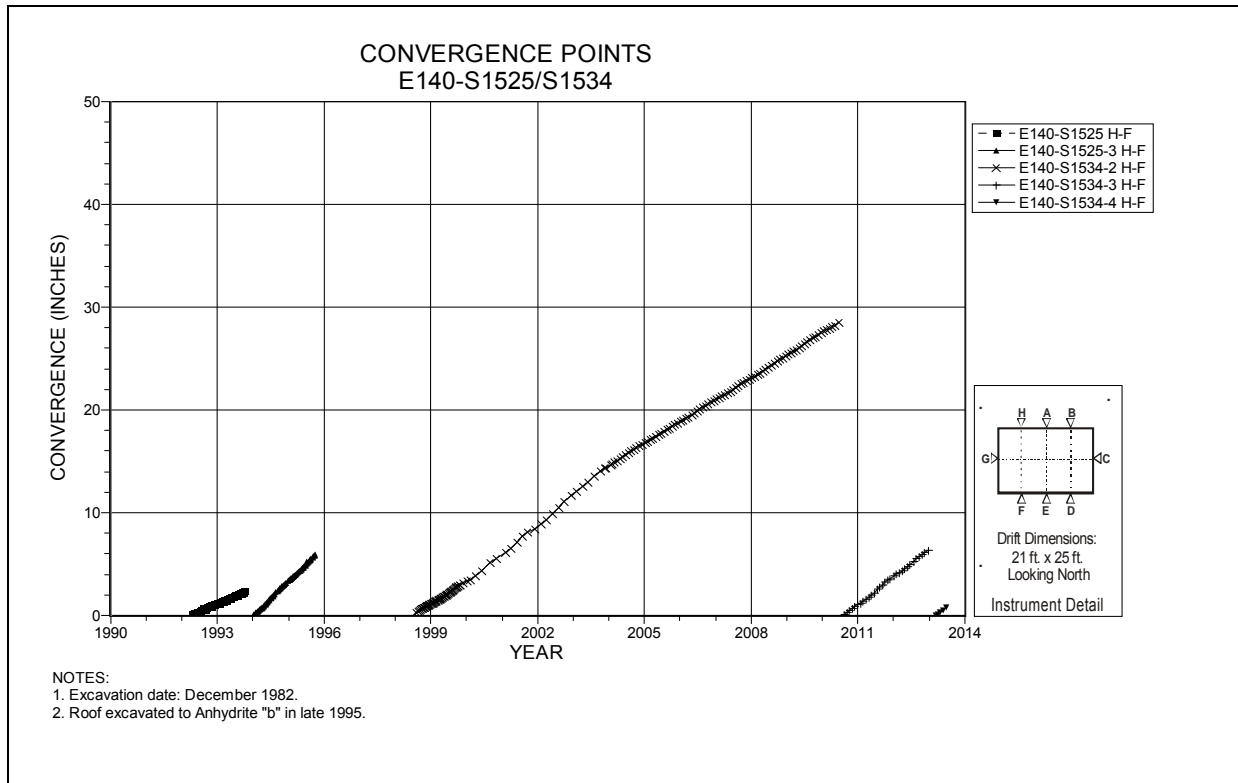
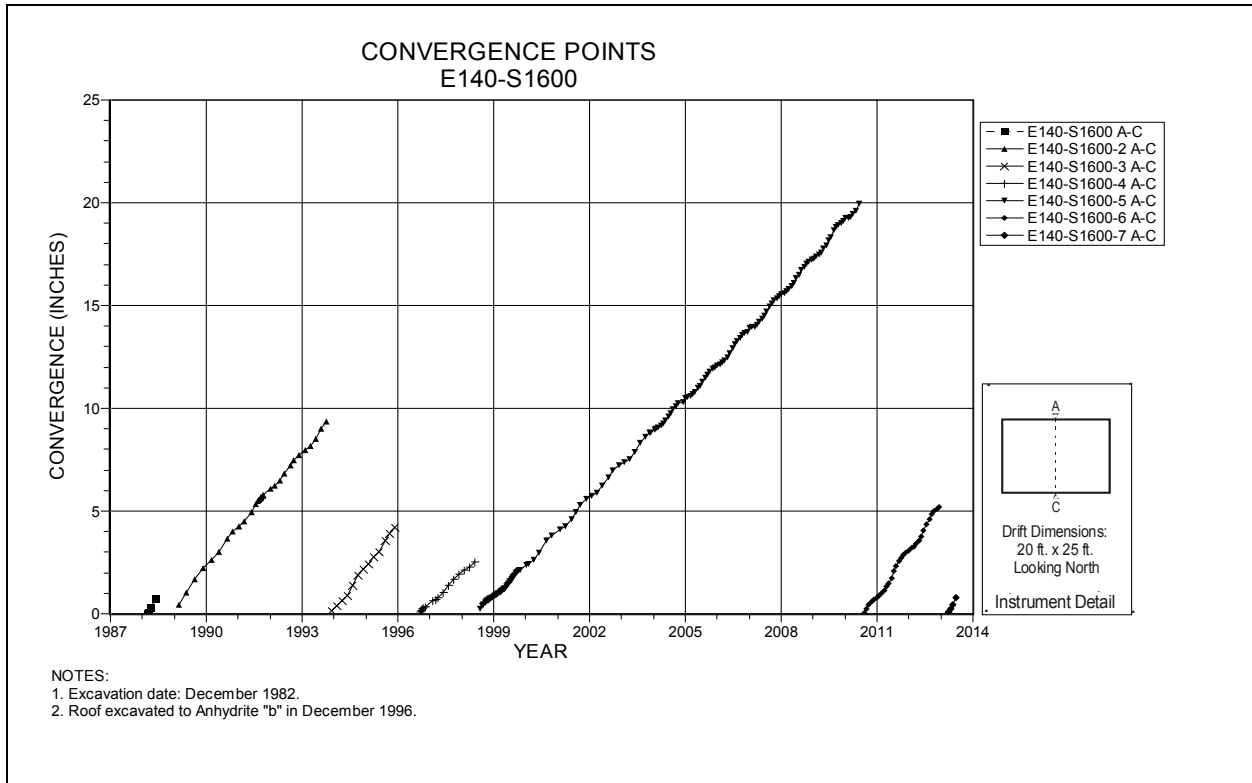
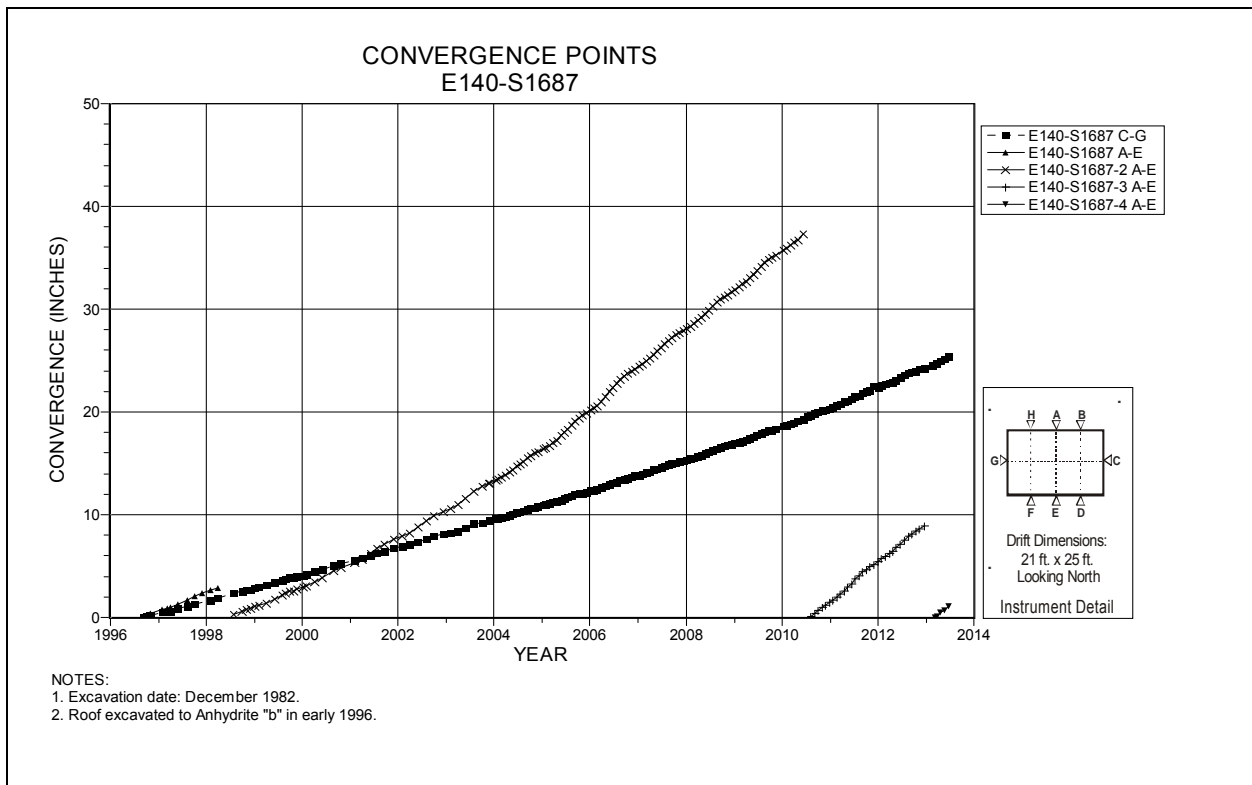

Figure 4-92 Convergence Point Array
E140 S1525/S1534 – Roof to Floor – West Quarter Point



**Figure 4-93 Convergence Point Array
E140 S1600 – Roof to Floor**



**Figure 4-94 Convergence Point Array
E140 S1687 – Roof to Floor – Centerline and Rib to Rib**

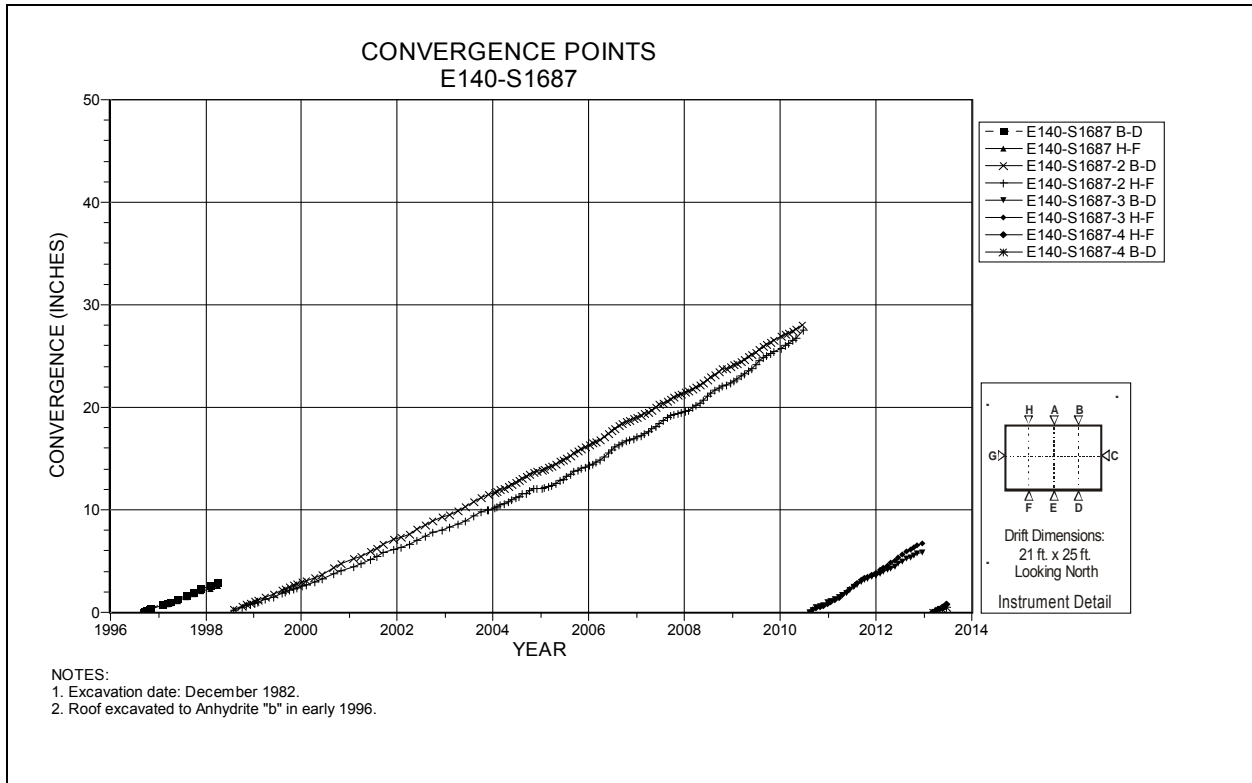

Figure 4-95 Convergence Point Array
E140 S1687 – Roof to Floor – Quarter Points

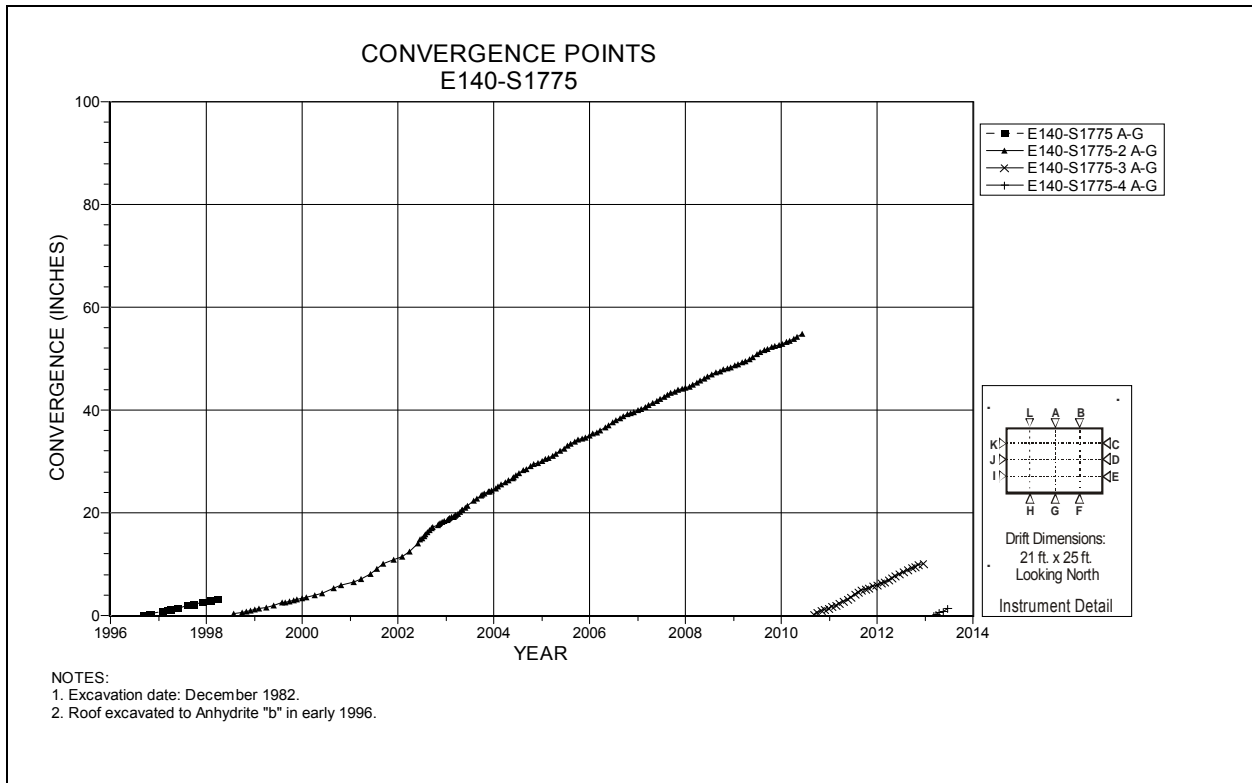
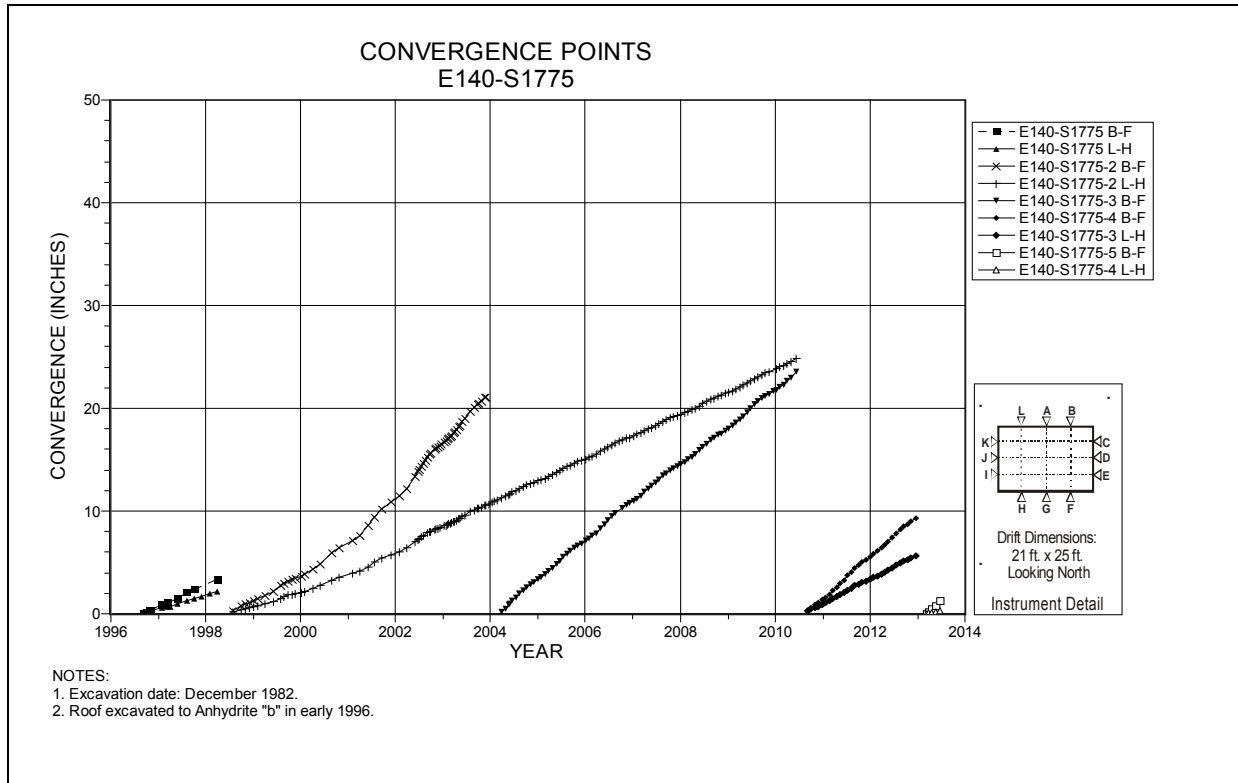
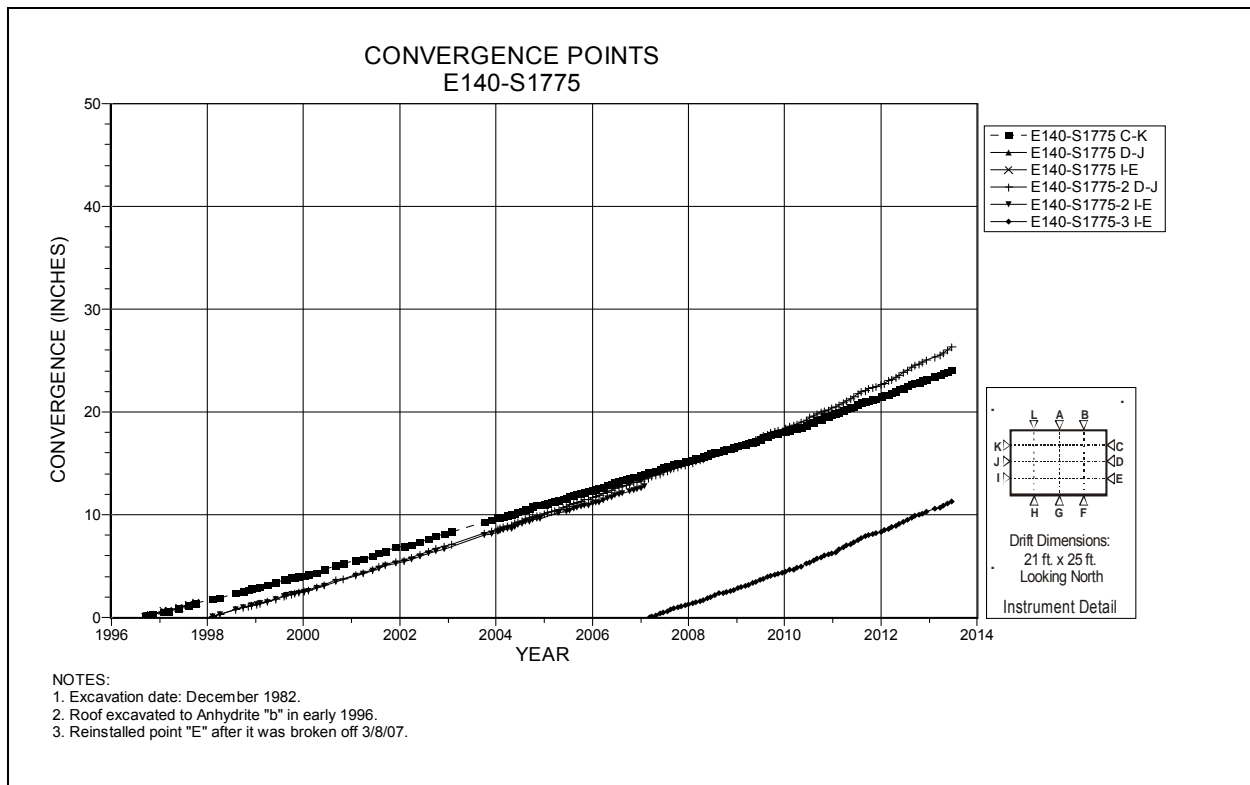

Figure 4-96 Convergence Point Array
E140 S1775 – Roof to Floor – Centerline



**Figure 4-97 Convergence Point Array
E140 S1775 – Roof to Floor – Quarter Points**



**Figure 4-98 Convergence Point Array
E140 S1775 – Rib to Rib**

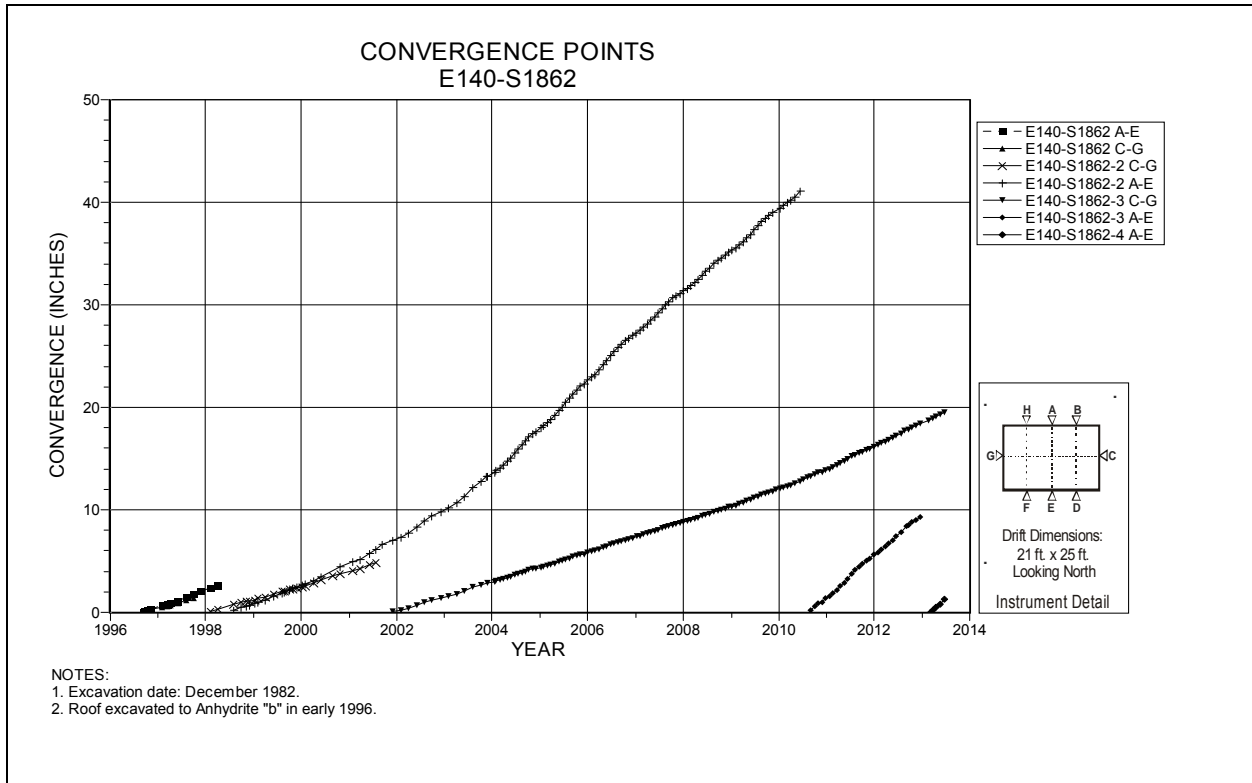

Figure 4-99 Convergence Point Array
E140 S1862 – Roof to Floor – Centerline and Rib to Rib

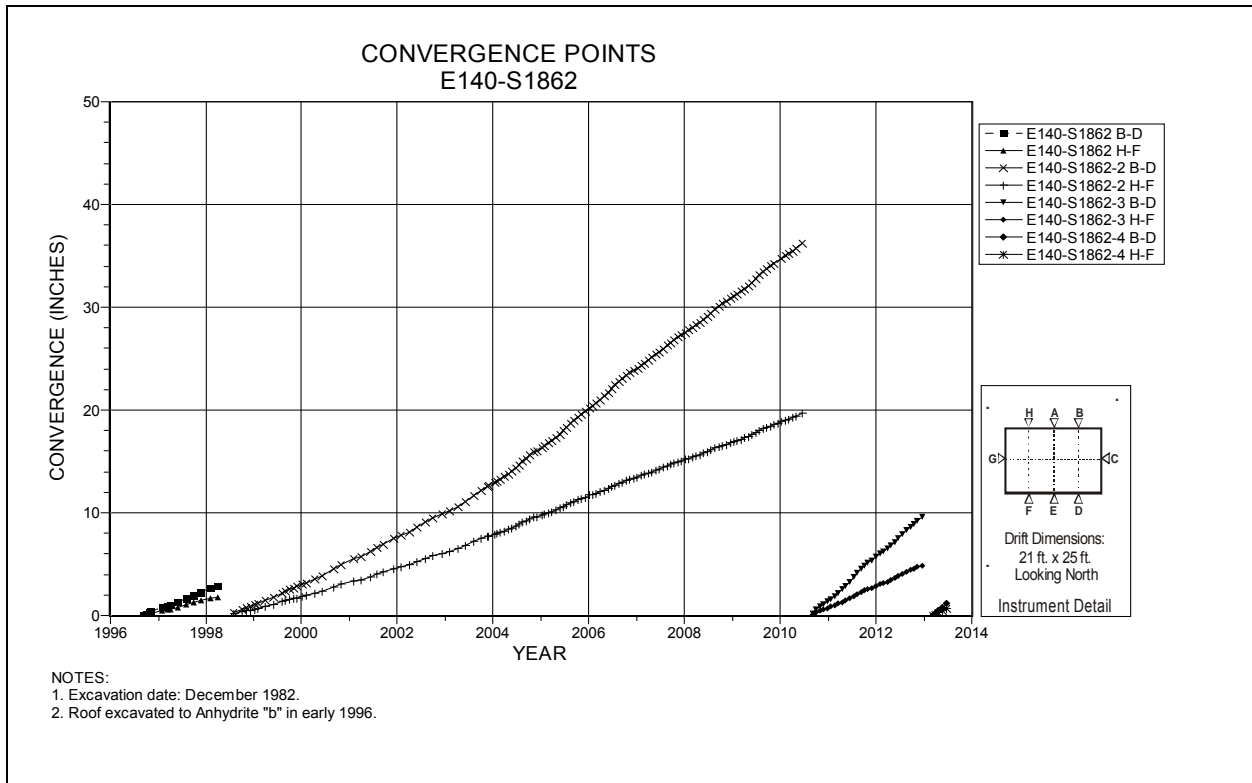
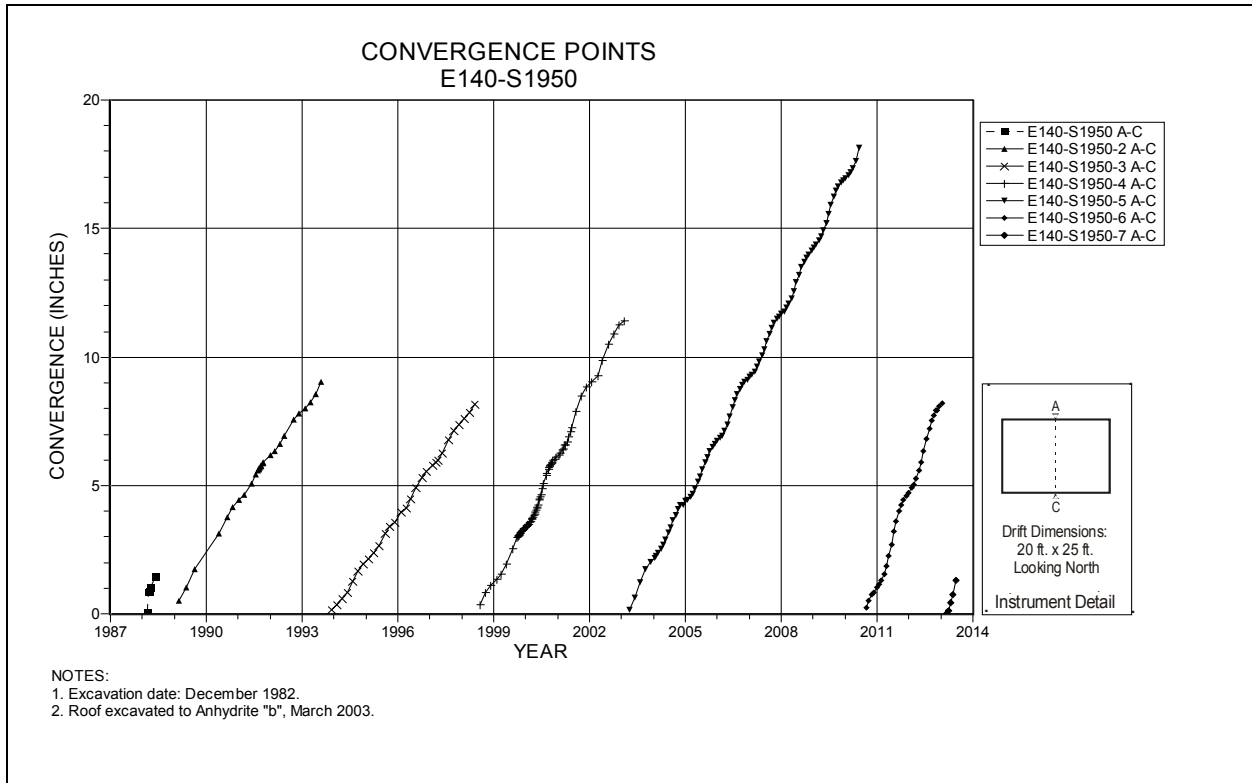
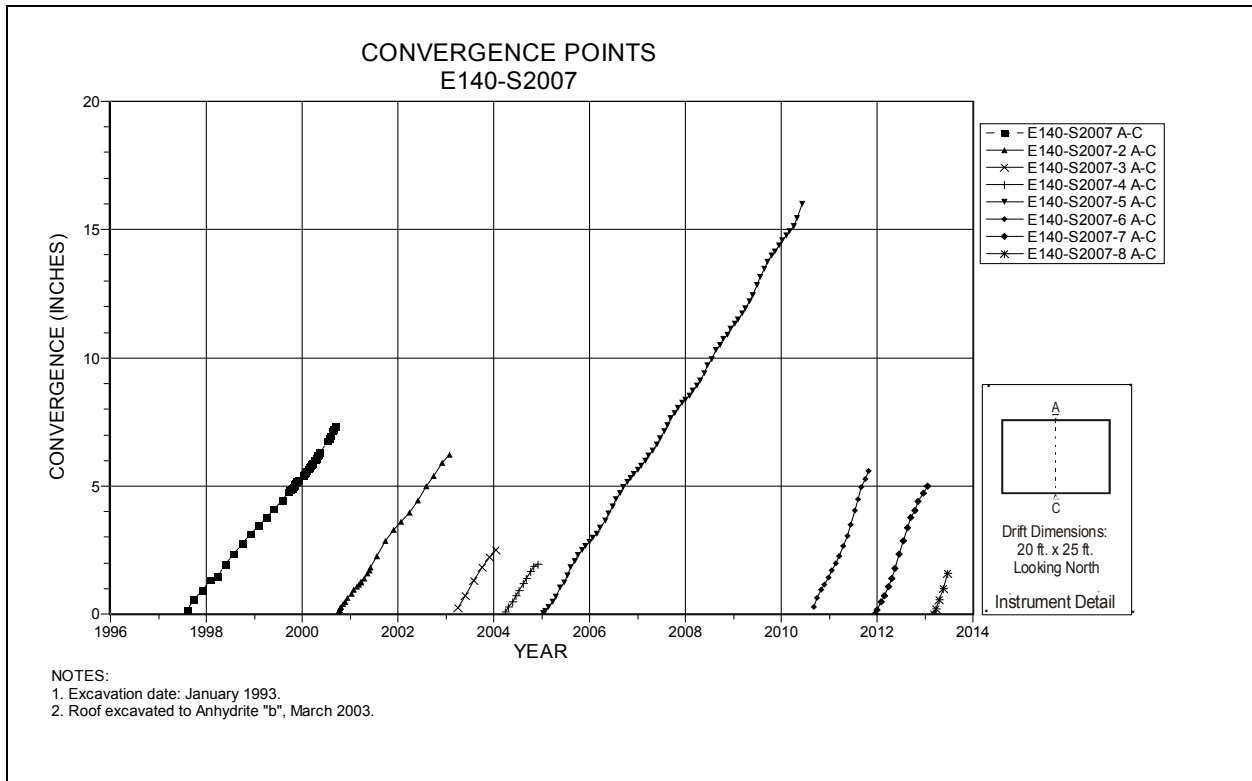

Figure 4-100 Convergence Point Array
E140 S1862 – Roof to Floor – Quarter Points



**Figure 4-101 Convergence Point Array
E140 S1950 – Roof to Floor**



**Figure 4-102 Convergence Point Array
E140 S2007 – Roof to Floor**

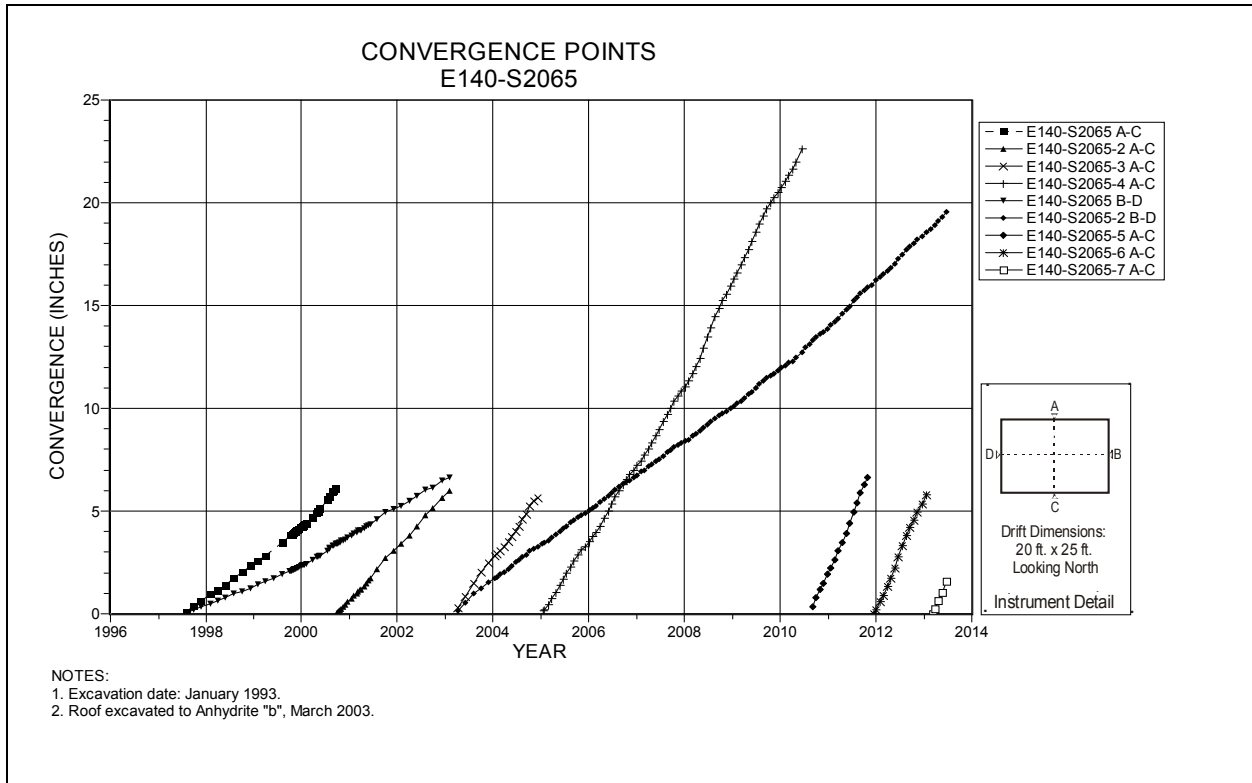

Figure 4-103 Convergence Point Array
E140 S2065 – All Chords

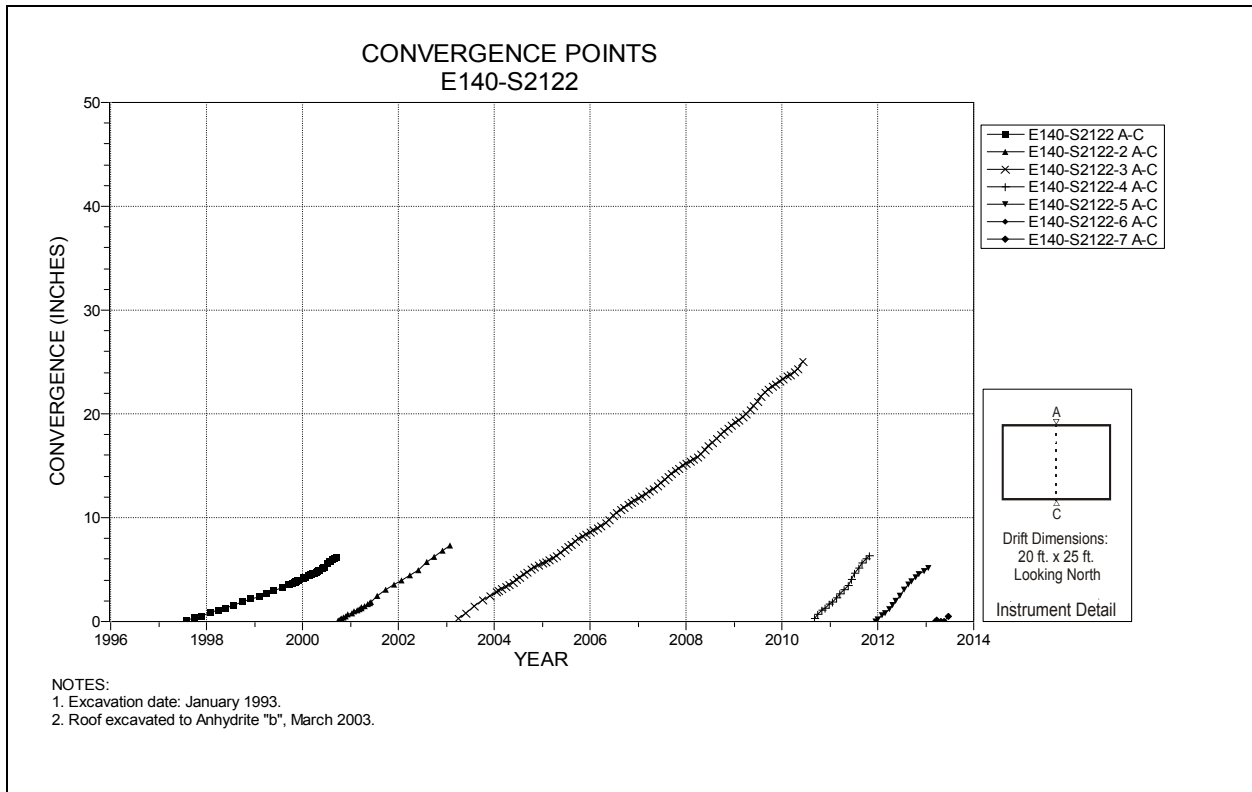

Figure 4-104 Convergence Point Array
E140 S2122 – Roof to Floor

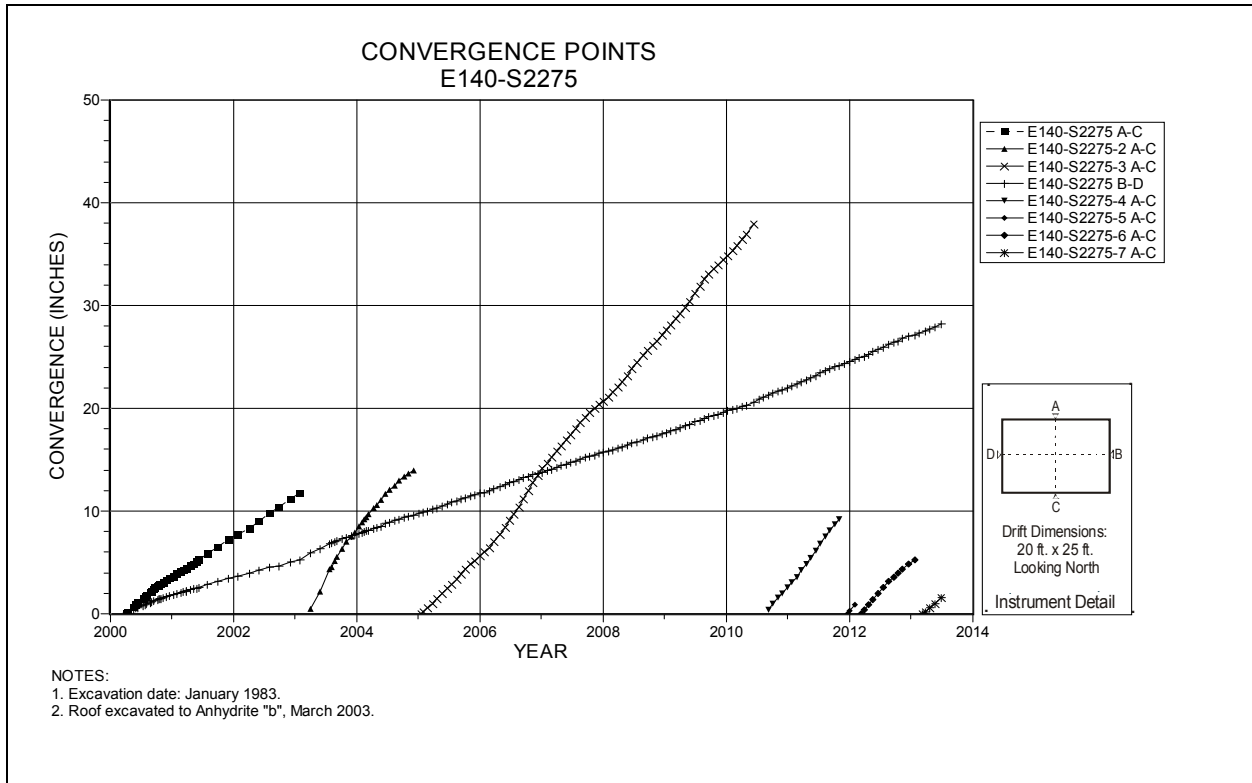

Figure 4-105 Convergence Point Array
E140 S2275 – All Chords

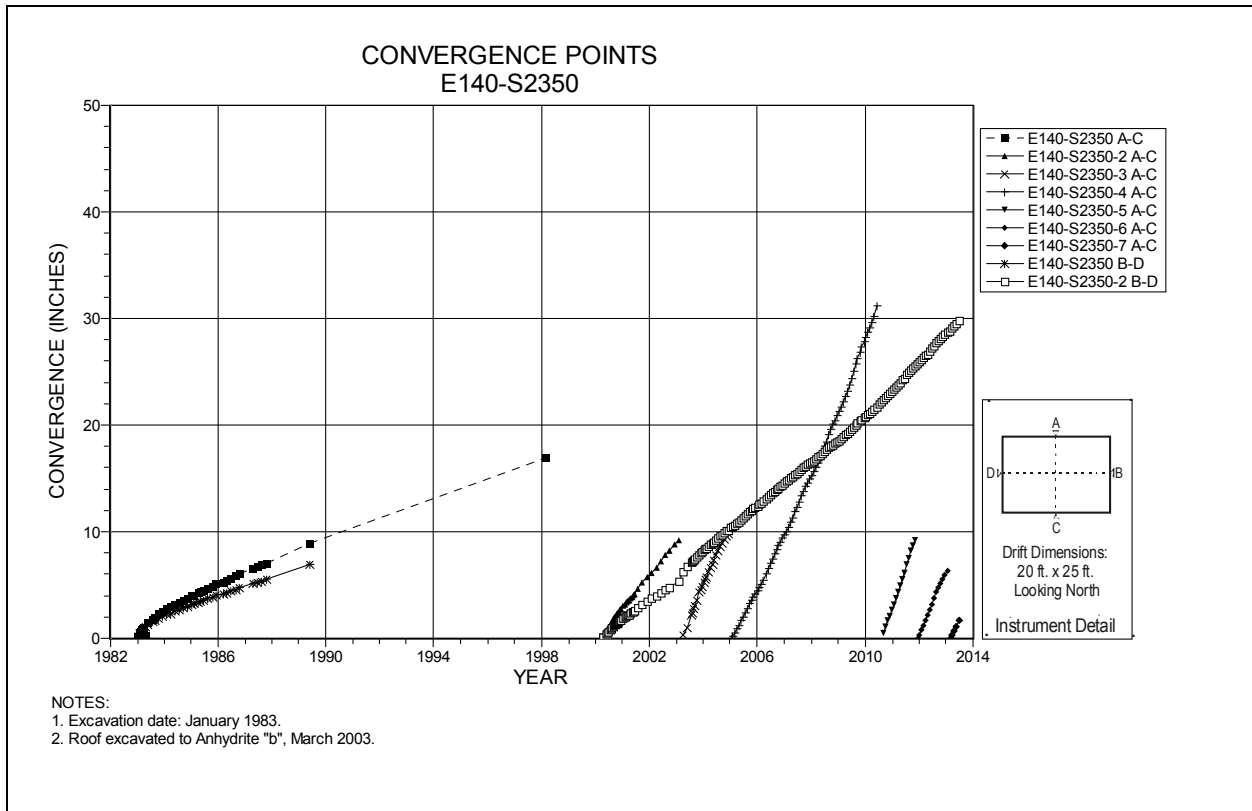

Figure 4-106 Convergence Point Array
E140 S2350 – All Chords

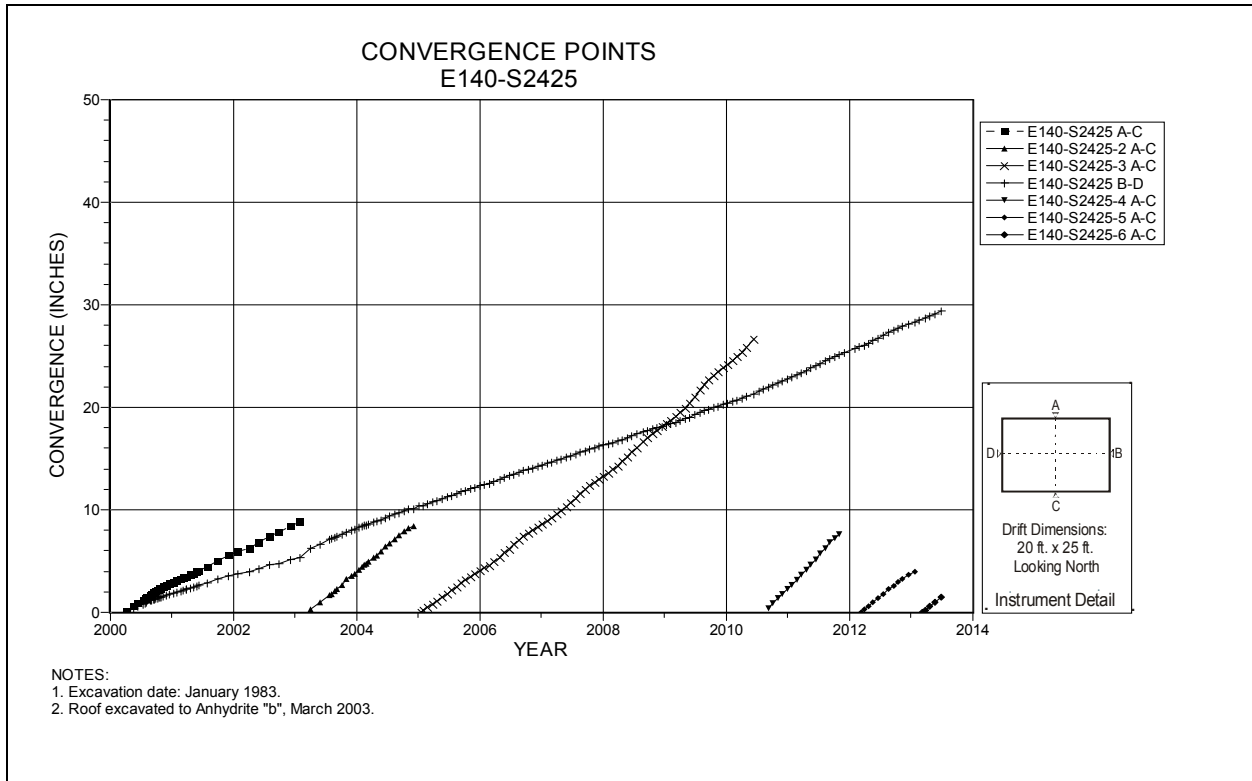

Figure 4-107 Convergence Point Array
E140 S2425 – All Chords

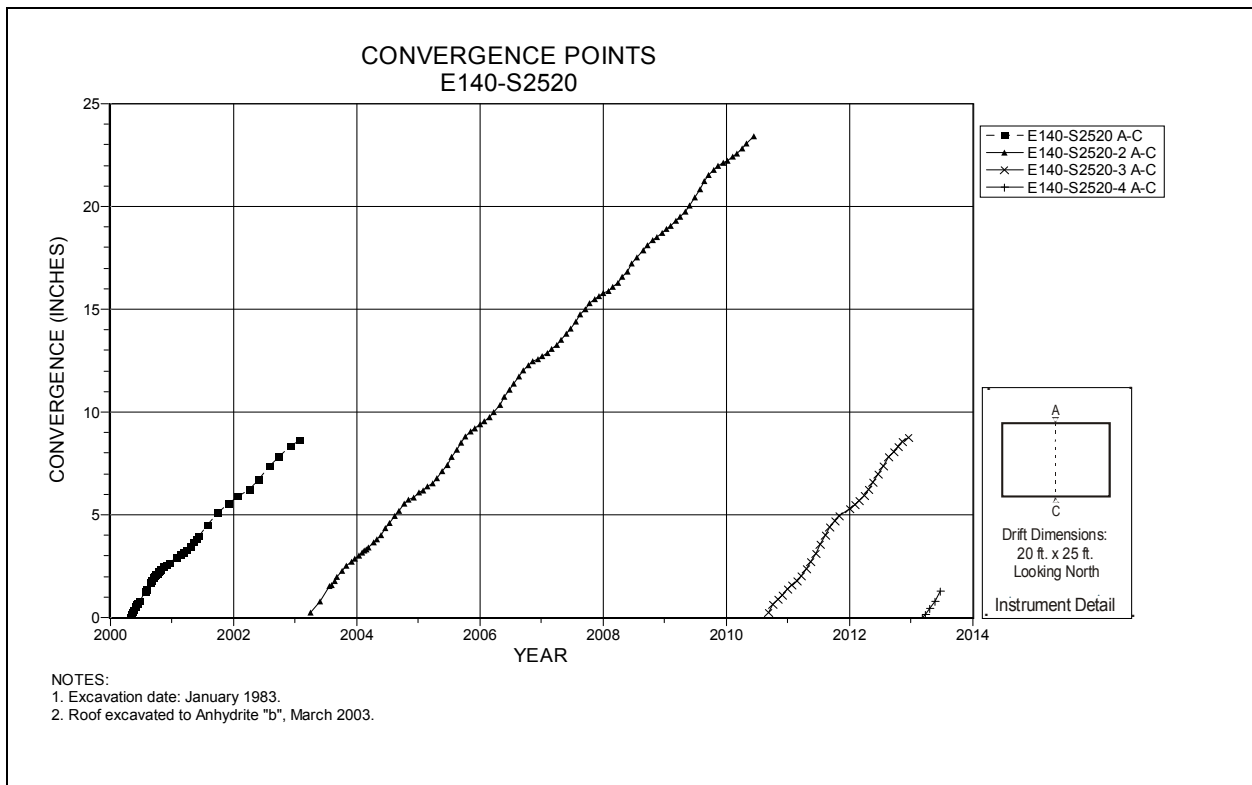

Figure 4-108 Convergence Point Array
E140 S2520 – Roof to Floor

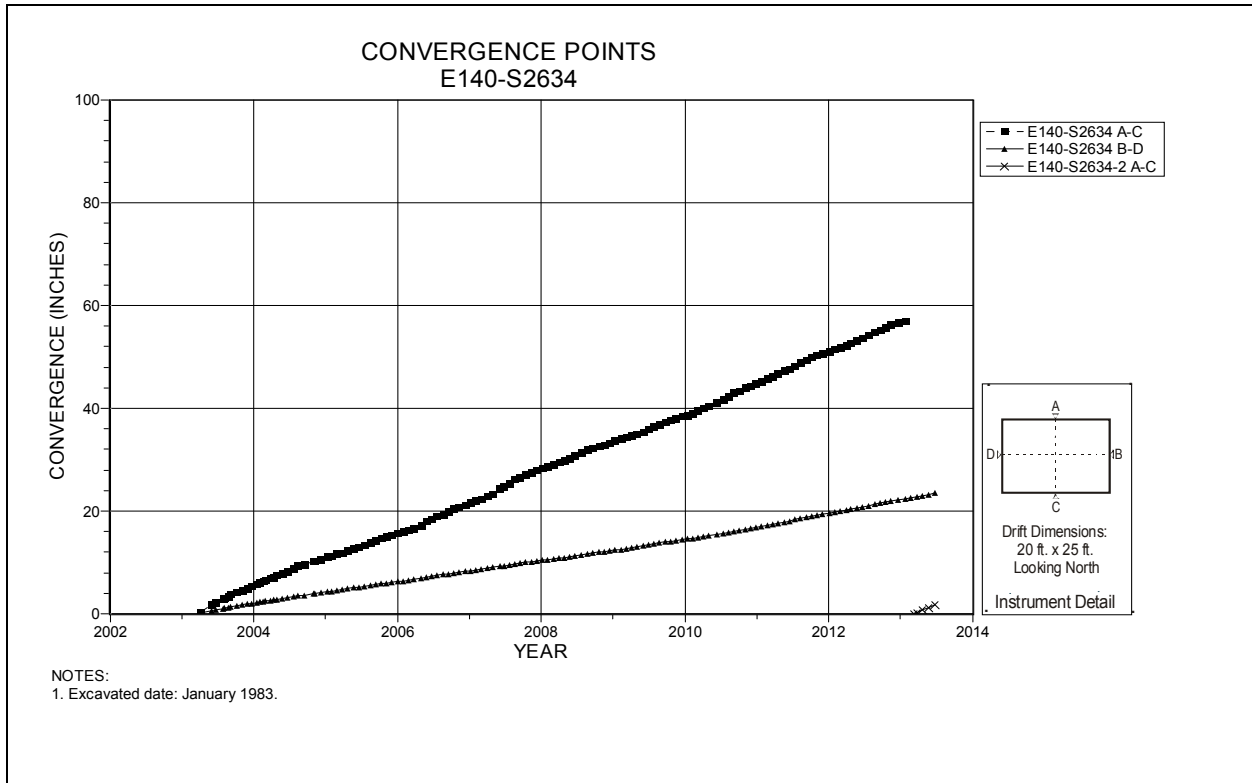

Figure 4-109 Convergence Point Array
E140 S2634 – All Chords

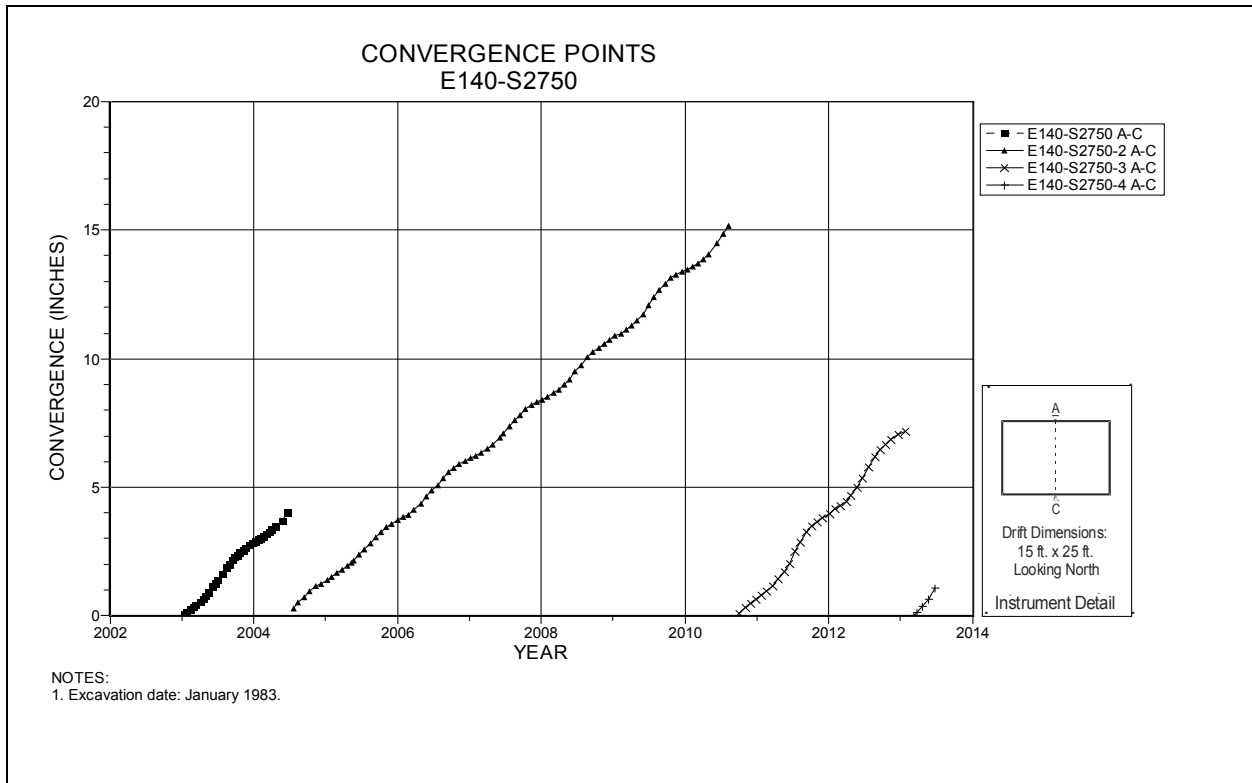

Figure 4-110 Convergence Point Array
E140 S2750 – Roof to Floor

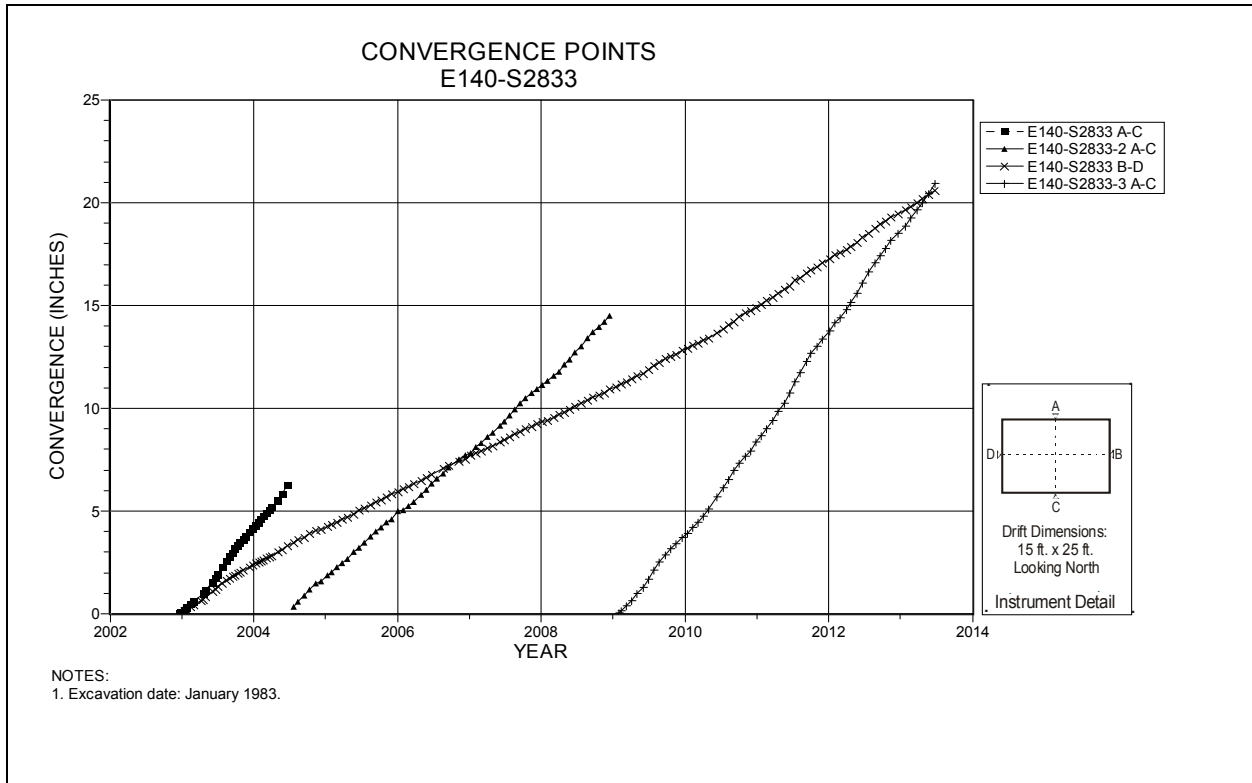

Figure 4-111 Convergence Point Array
E140 S2833 – All Chords

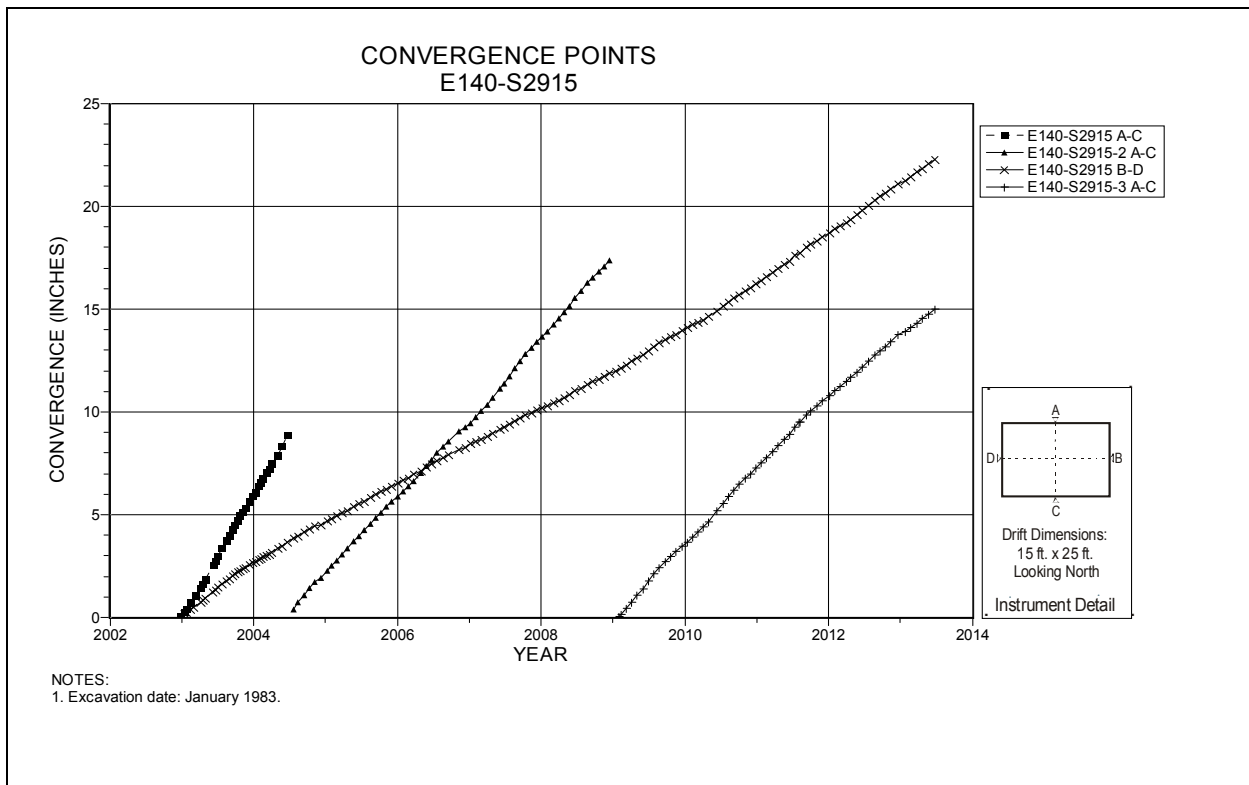

Figure 4-112 Convergence Point Array
E140 S2915 – All Chords

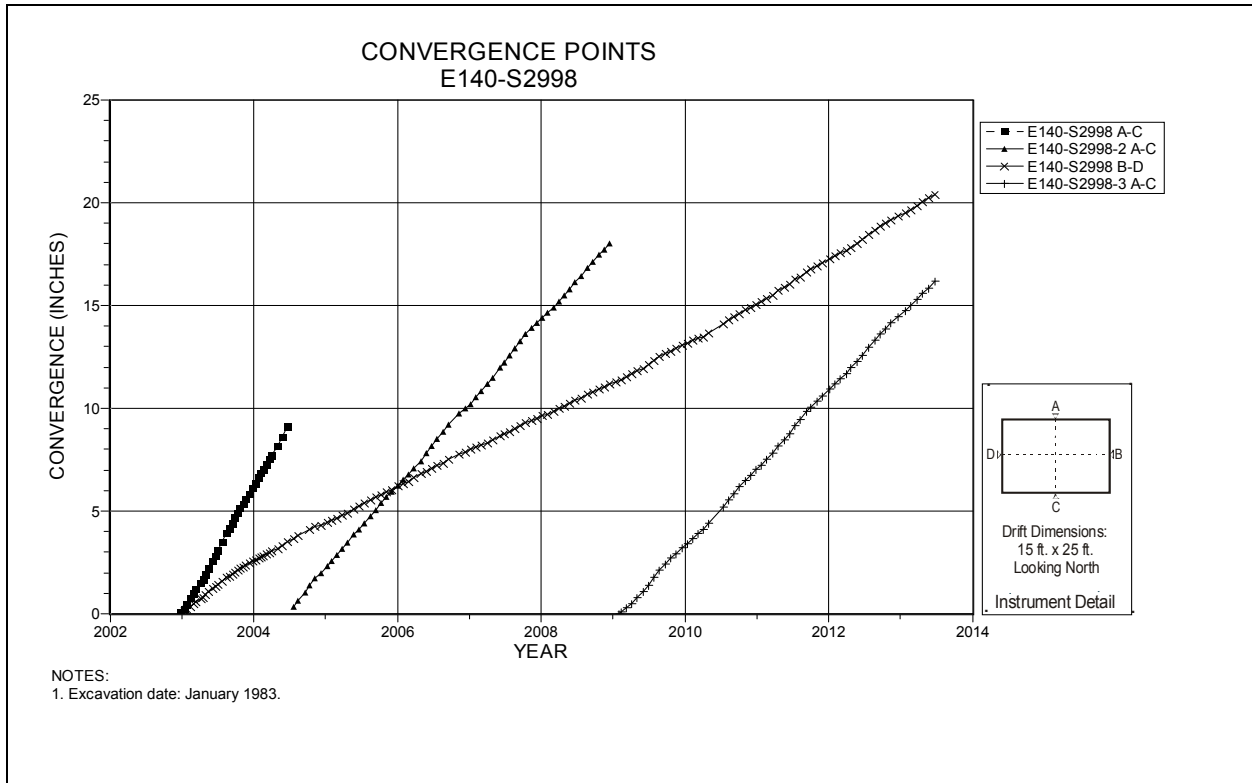

Figure 4-113 Convergence Point Array
E140 S2998 – All Chords

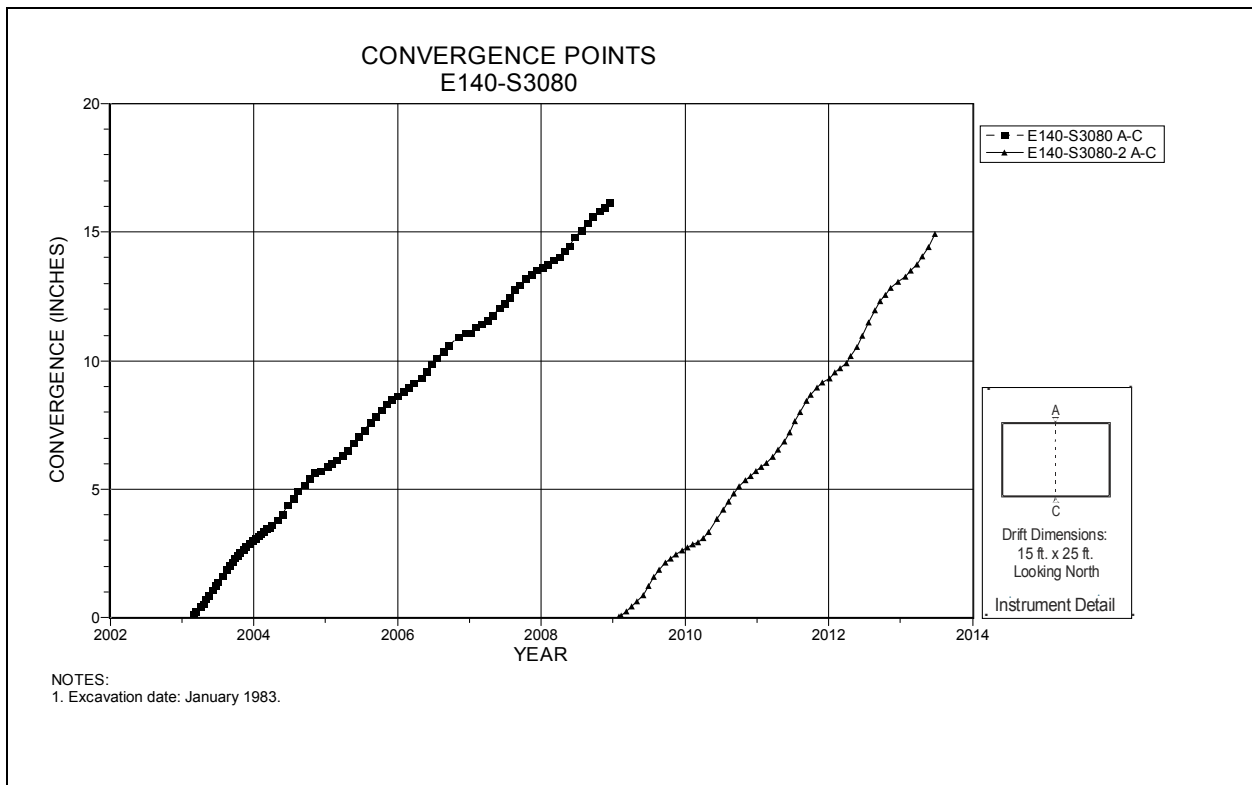

Figure 4-114 Convergence Point Array
E140 S3080 – Roof to Floor

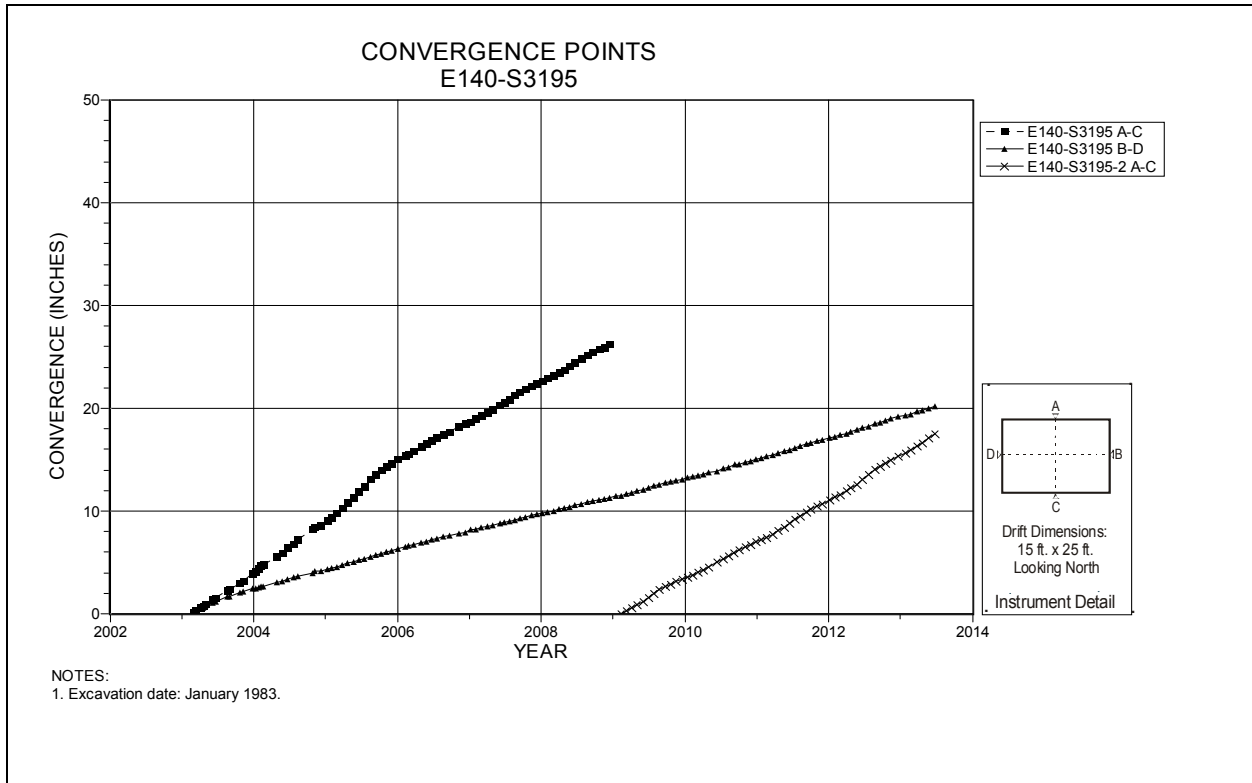

Figure 4-115 Convergence Point Array
E140 S3195 – All Chords

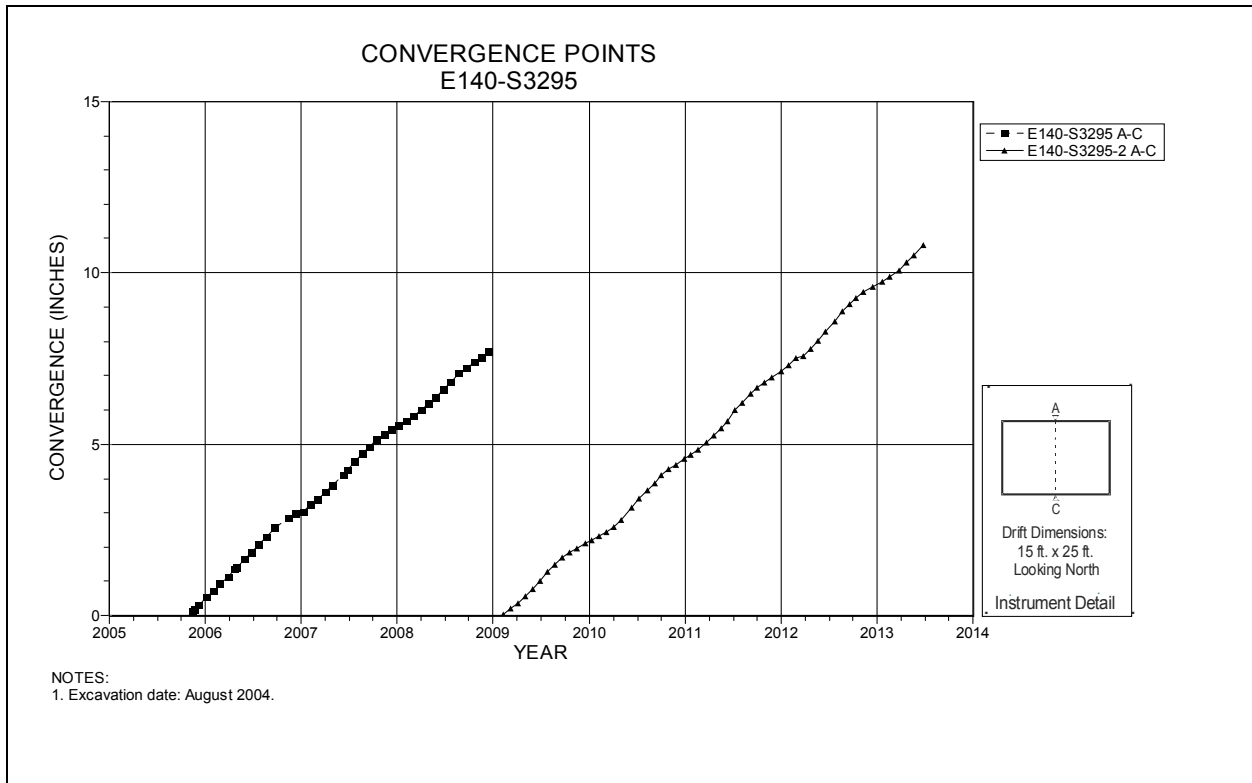
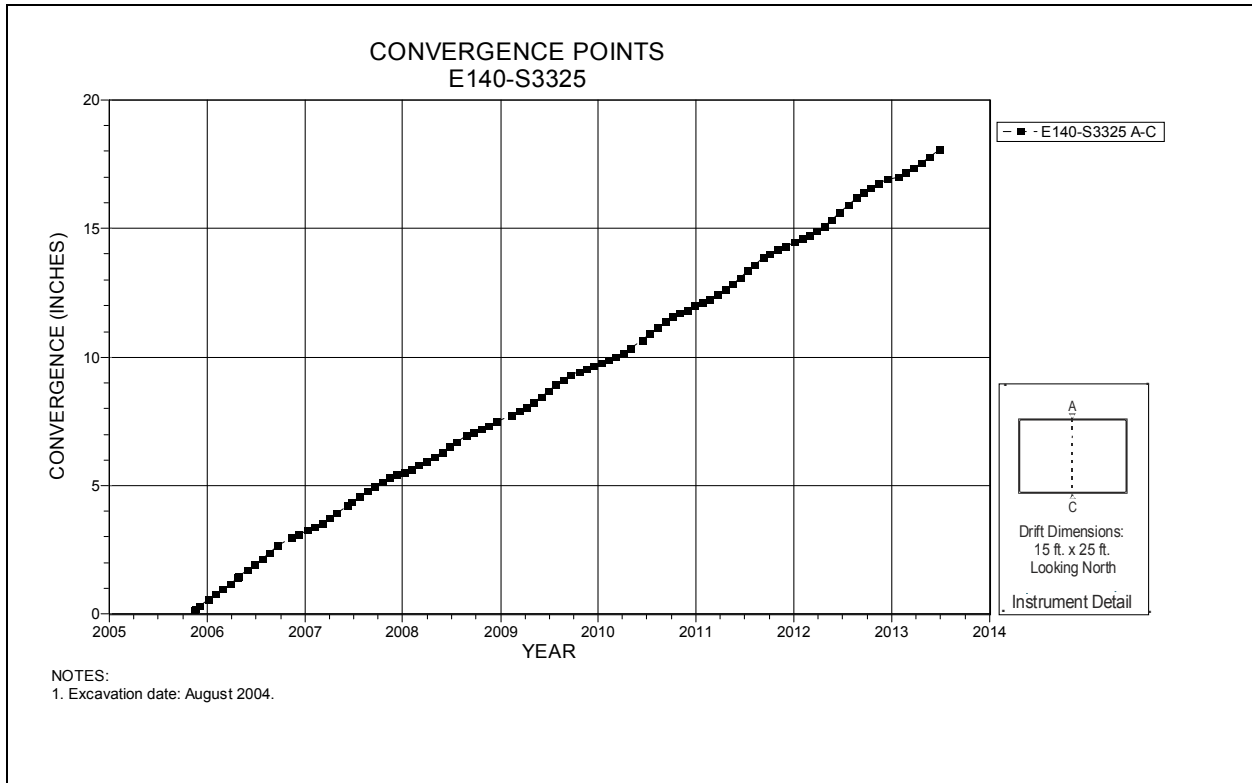
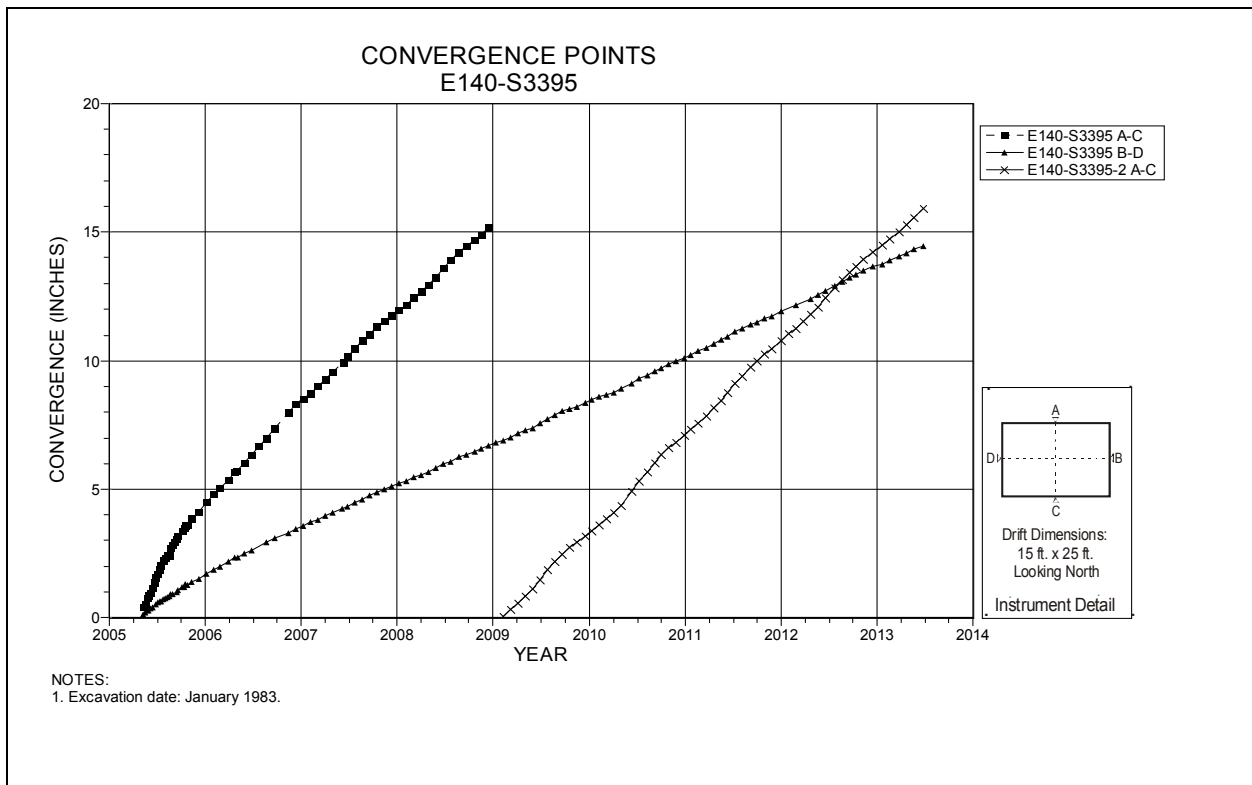

Figure 4-116 Convergence Point Array
E140 S3295 – Roof to Floor



**Figure 4-117 Convergence Point Array
E140 S3325 – Roof to Floor**



**Figure 4-118 Convergence Point Array
E140 S3395 – All Chords**

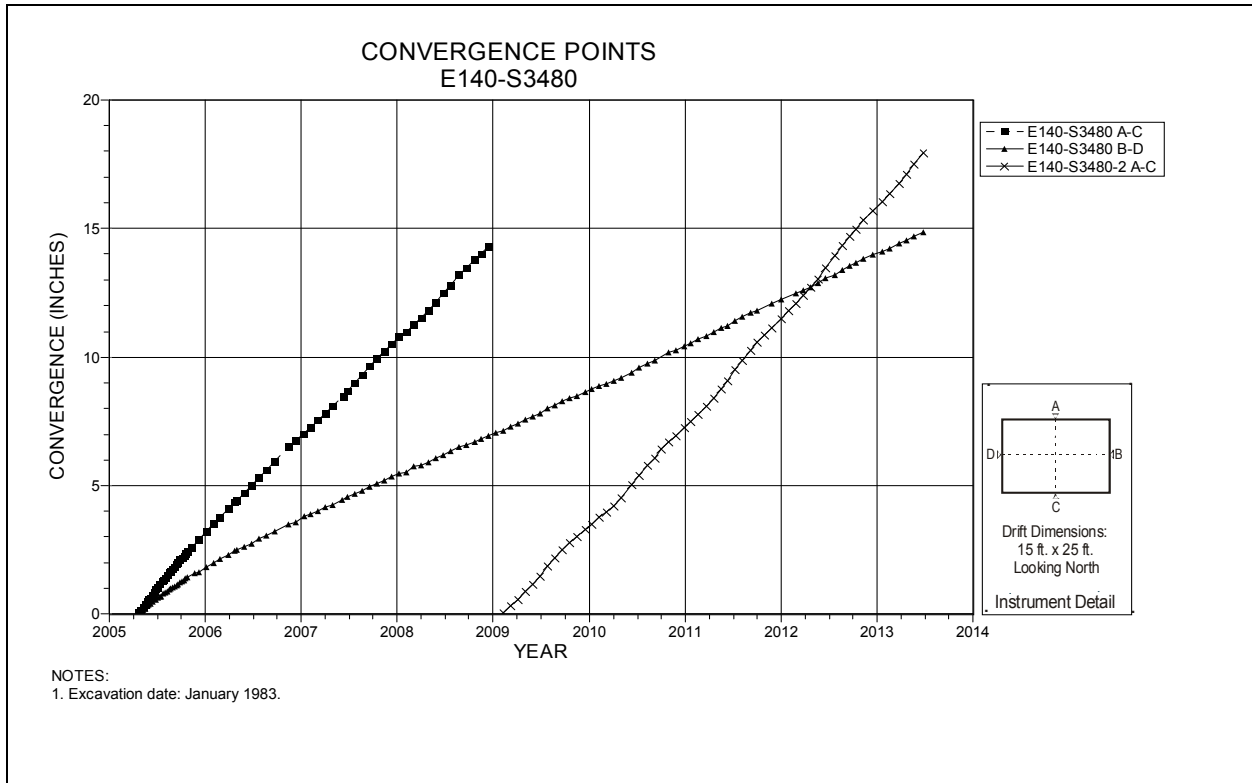

Figure 4-119 Convergence Point Array
E140 S3480 – All Chords

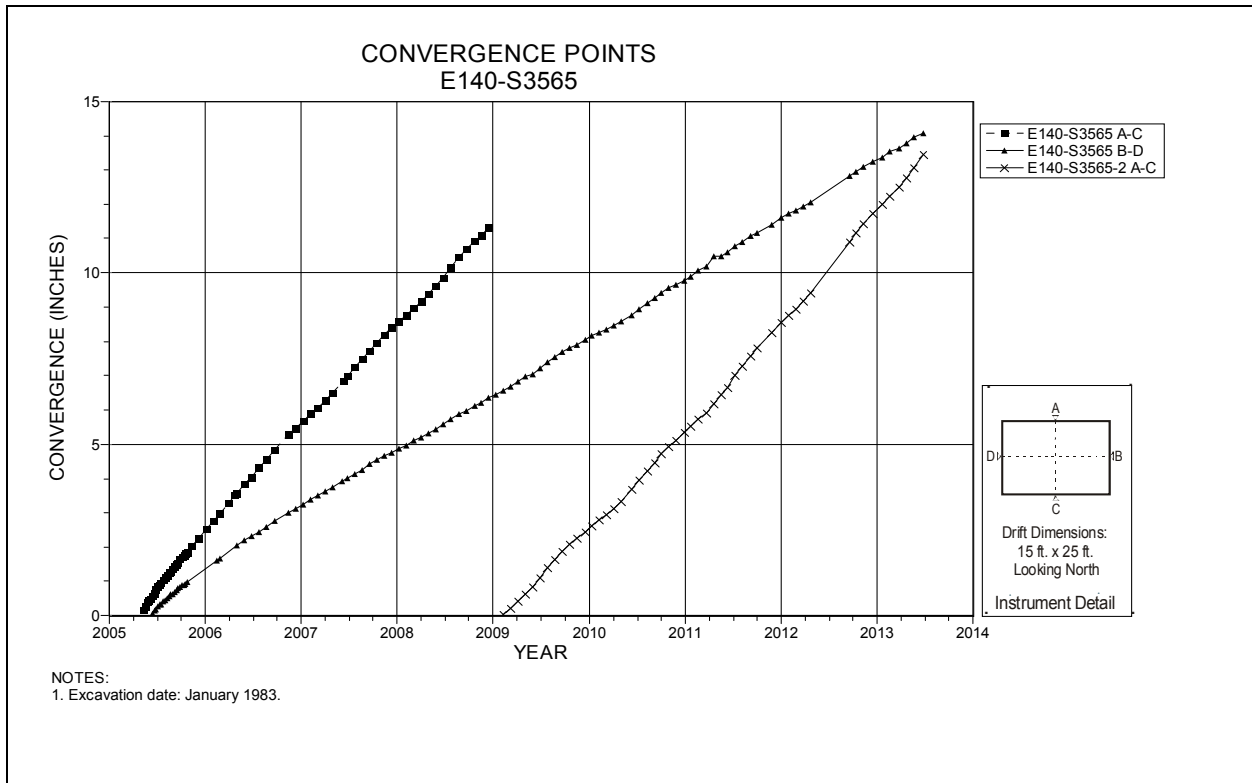

Figure 4-120 Convergence Point Array
E140 S3565 – All Chords

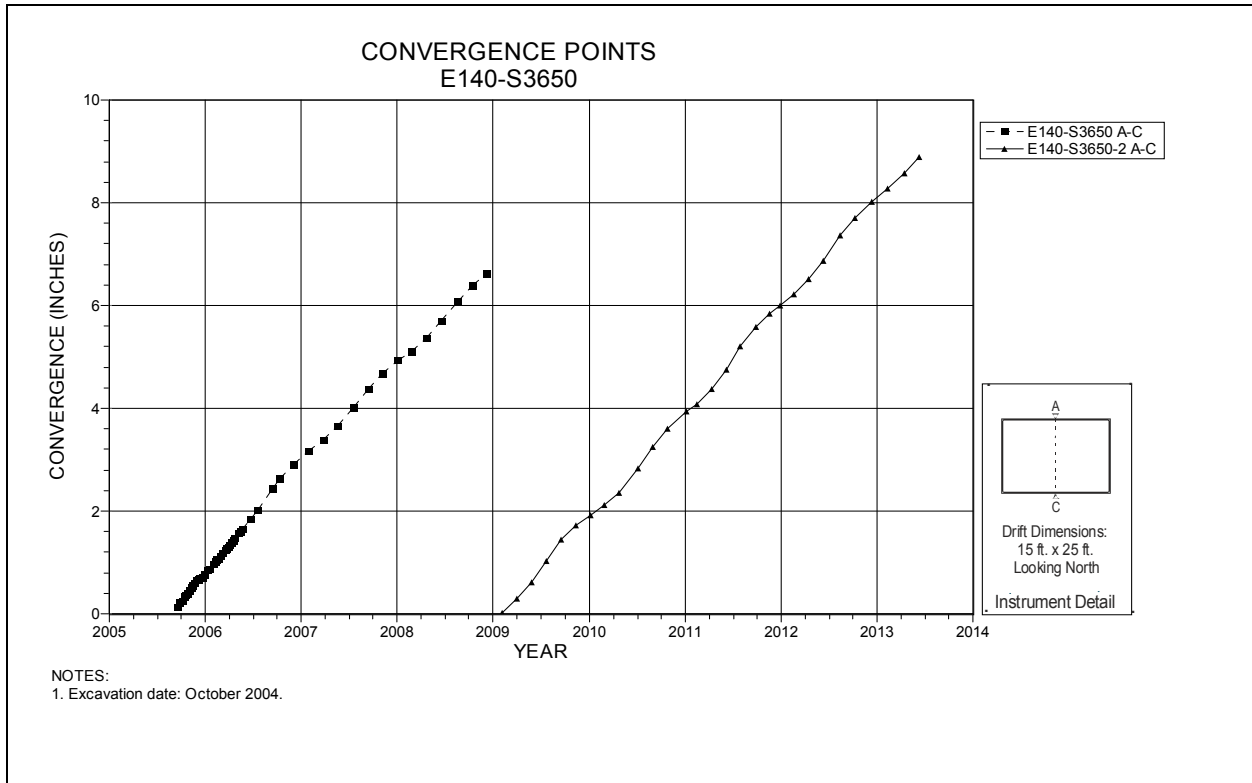

Figure 4-121 Convergence Point Array
E140 S3650 – Roof to Floor

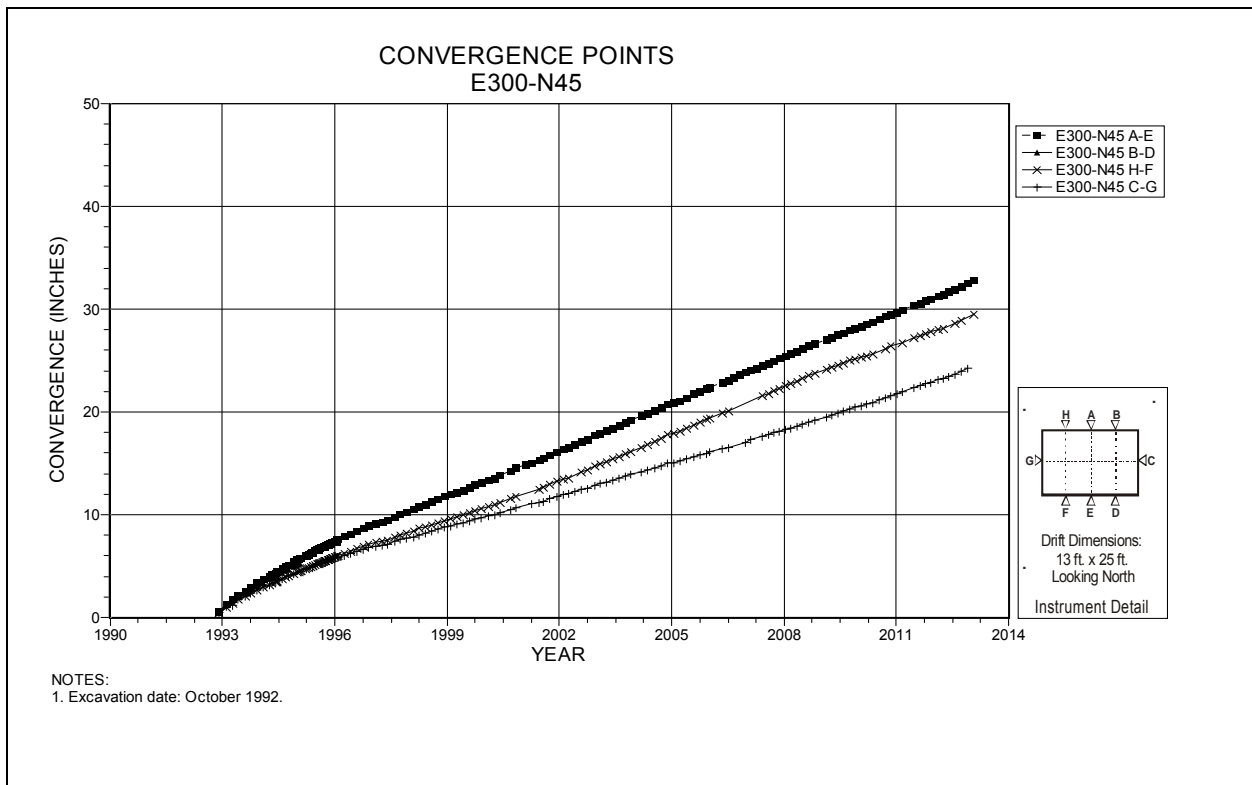

Figure 4-122 Convergence Point Array
E300 N45 – All Chords

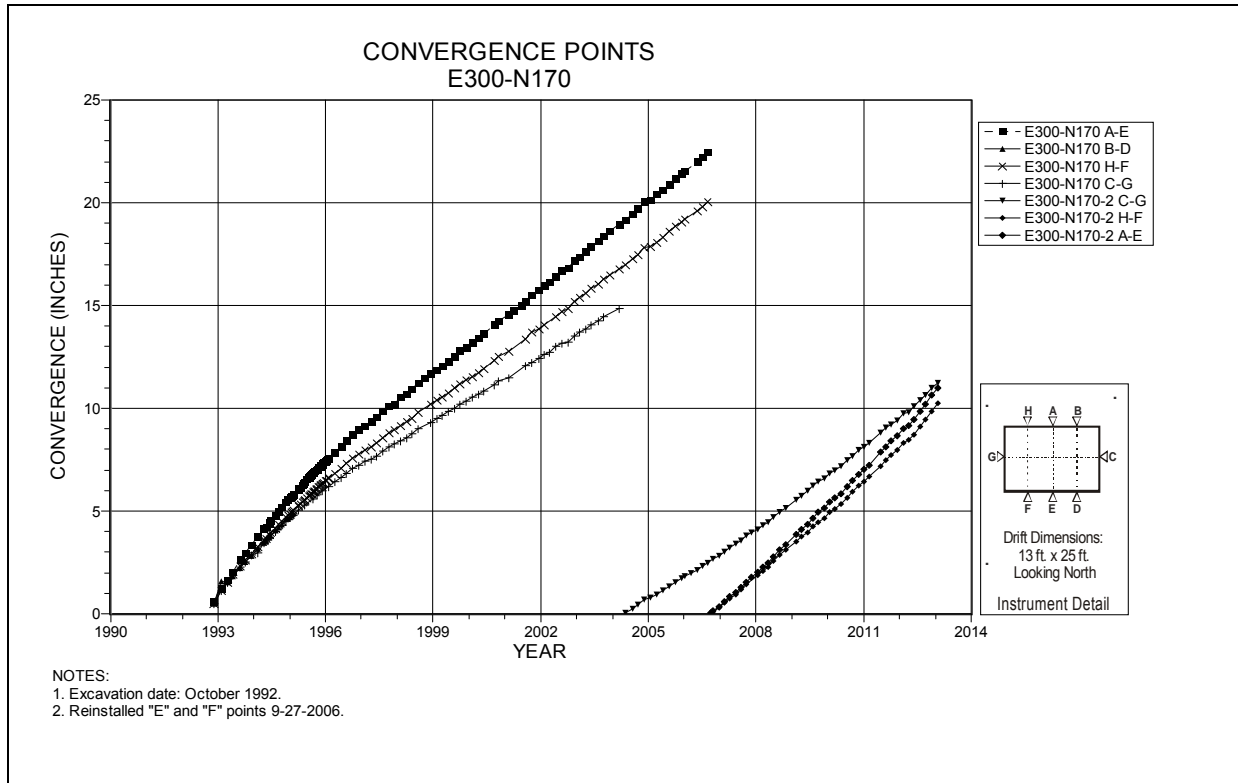

Figure 4-123 Convergence Point Array
E300 N170 – All Chords

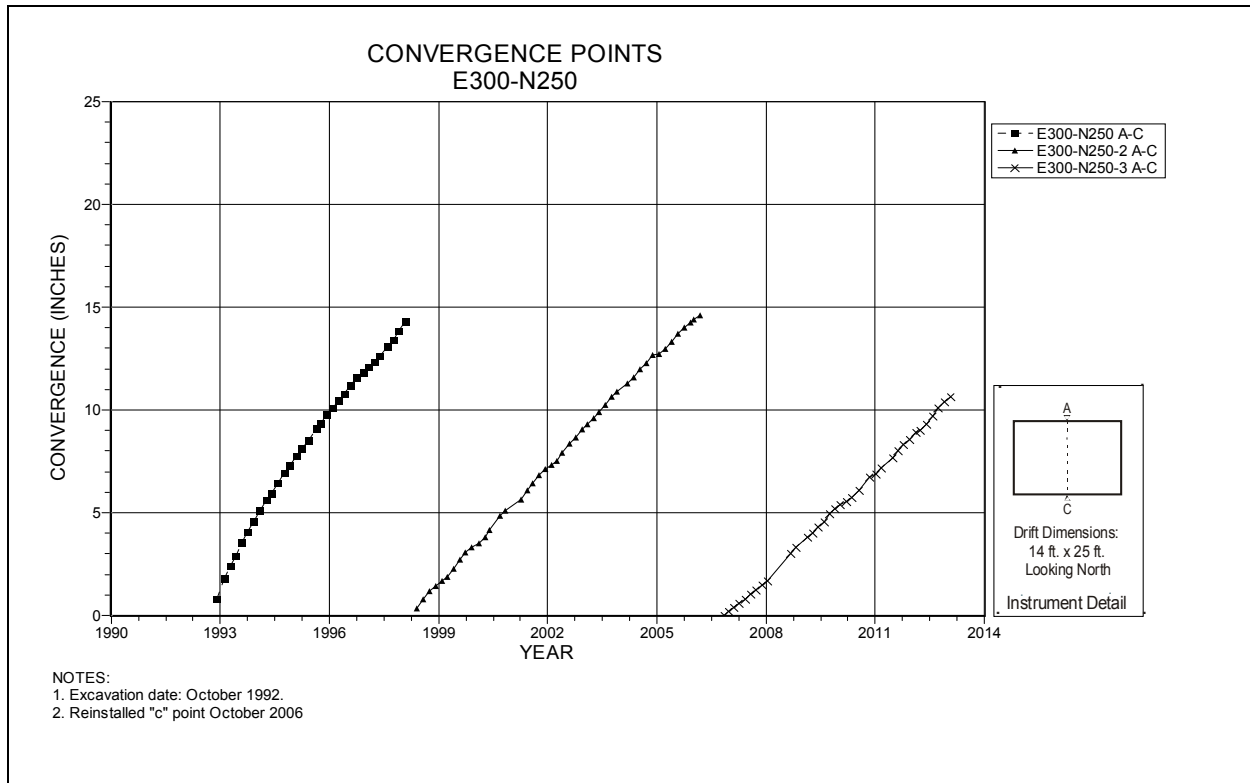

Figure 4-124 Convergence Point Array
E300 N250 – Roof to Floor

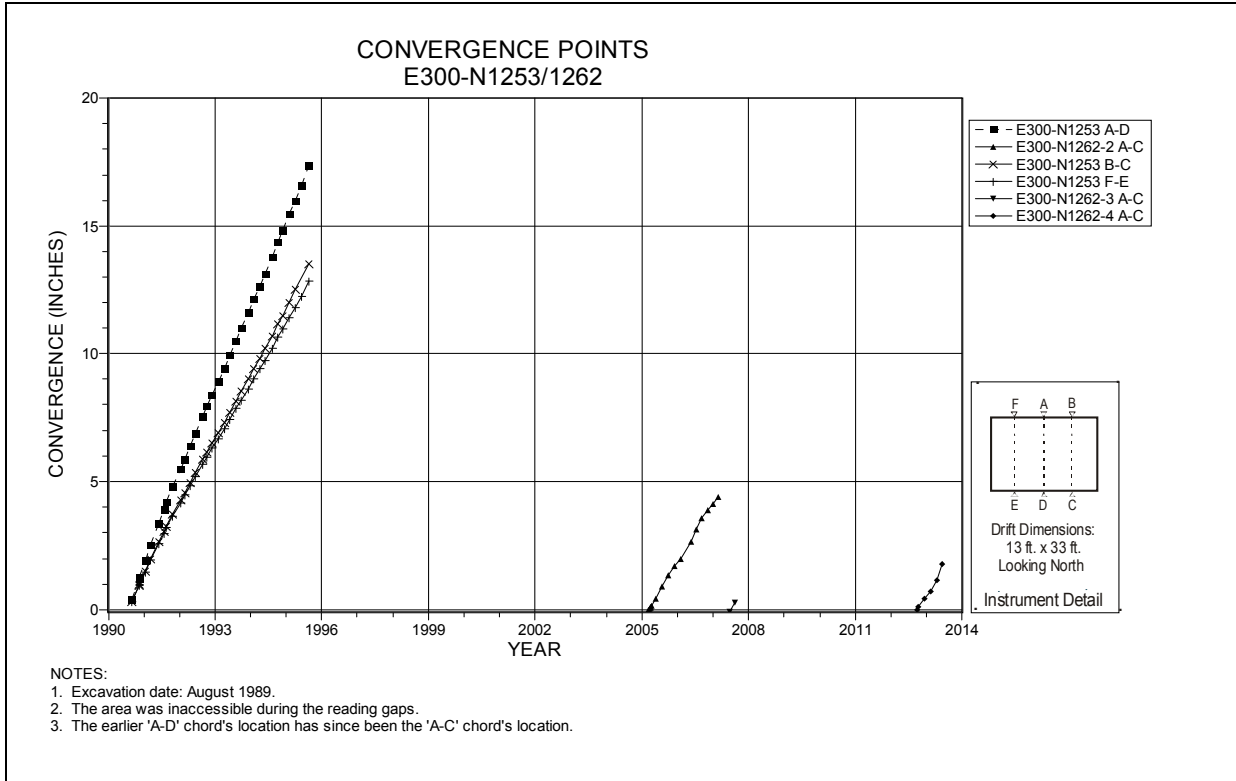

Figure 4-125 Convergence Point Array
E300 N1253/N1262 – Roof to Floor

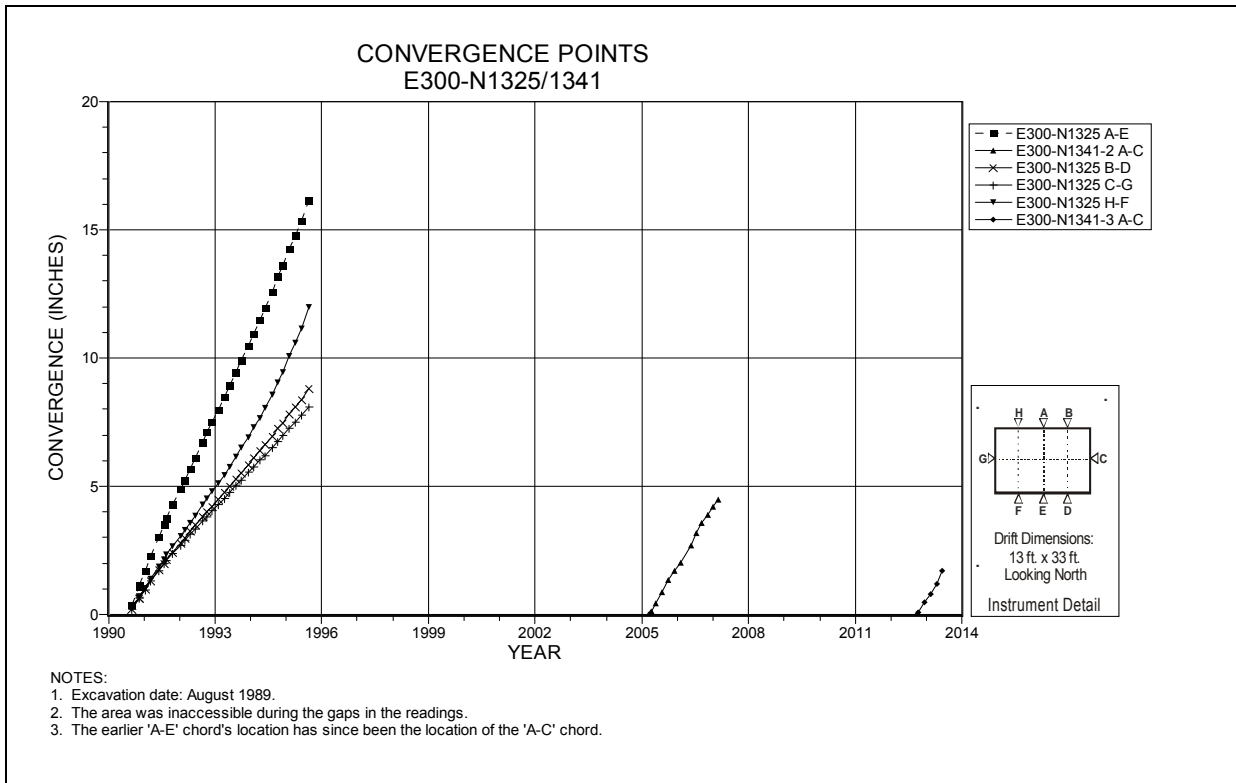

Figure 4-126 Convergence Point Array
E300 N1325/N1341 – All Chords

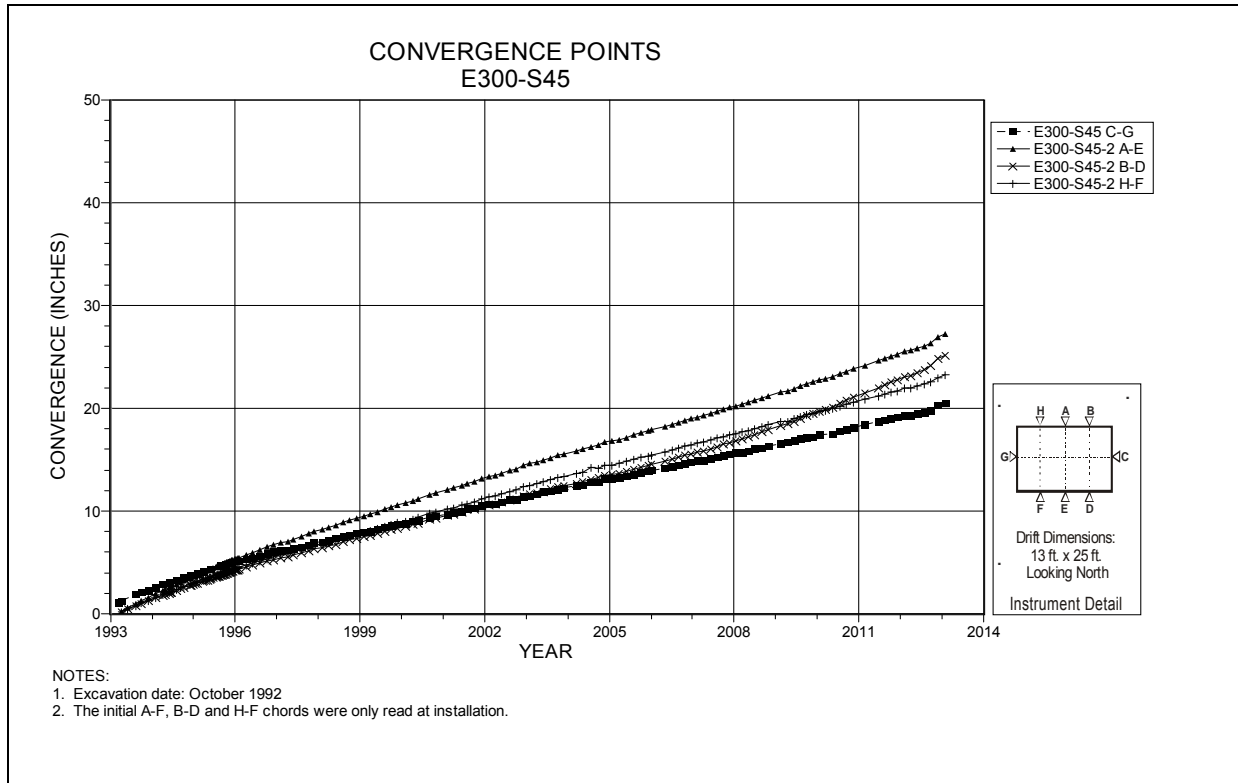

Figure 4-127 Convergence Point Array
E300 S45 – All Chords

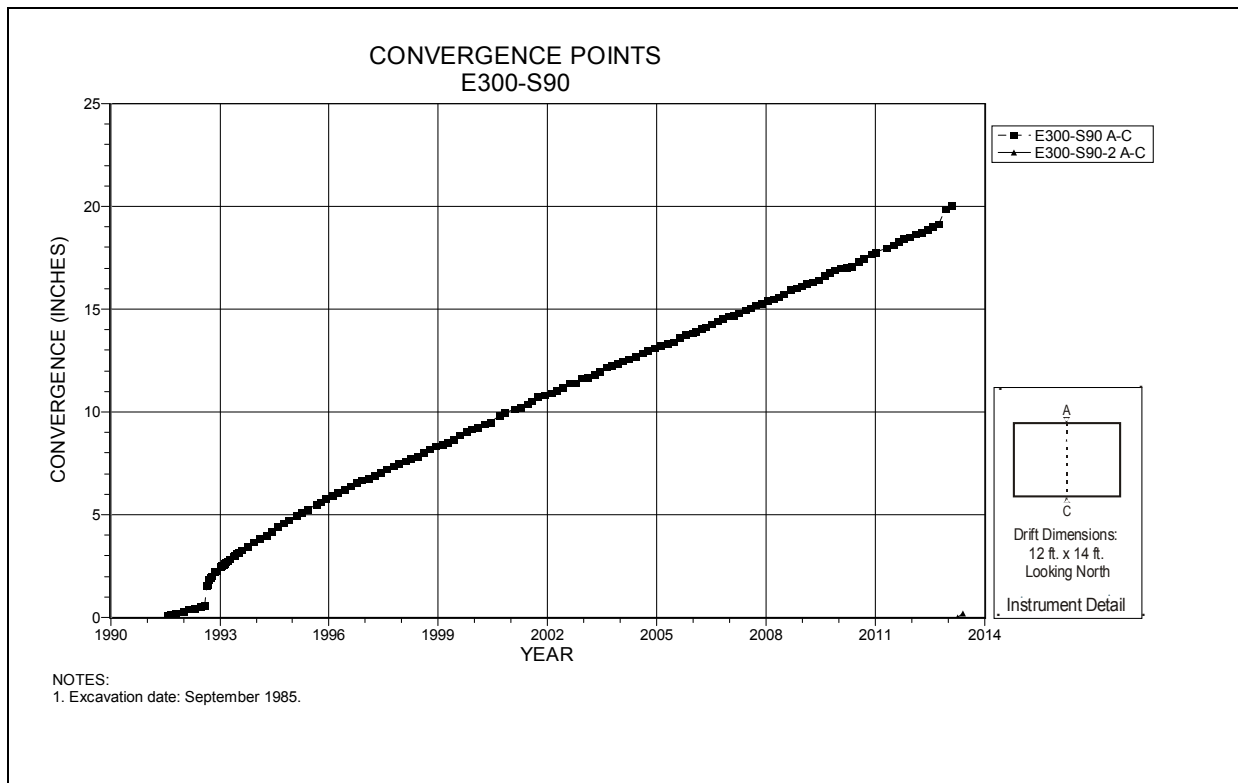

Figure 4-128 Convergence Point Array
E300 S90 – Roof to Floor

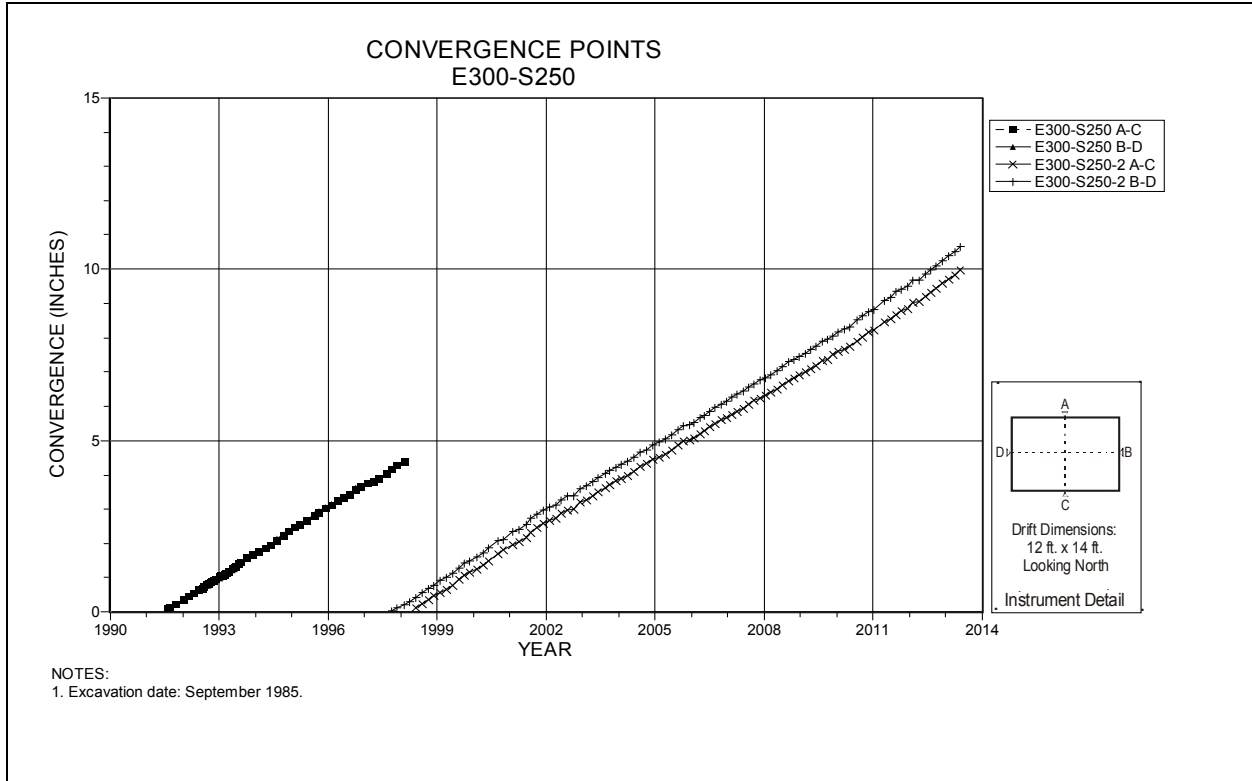

Figure 4-129 Convergence Point Array
E300 S250 – All Chords

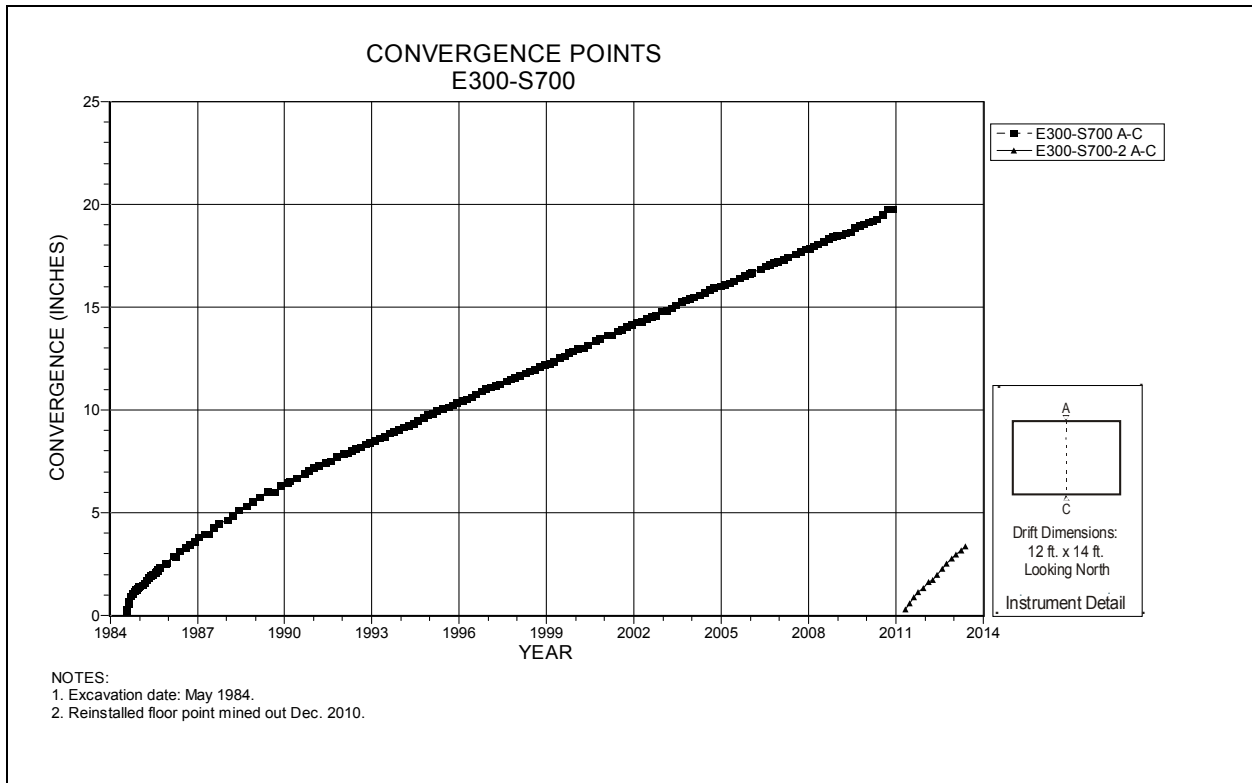

Figure 4-130 Convergence Point Array
E300 S700 – Roof to Floor

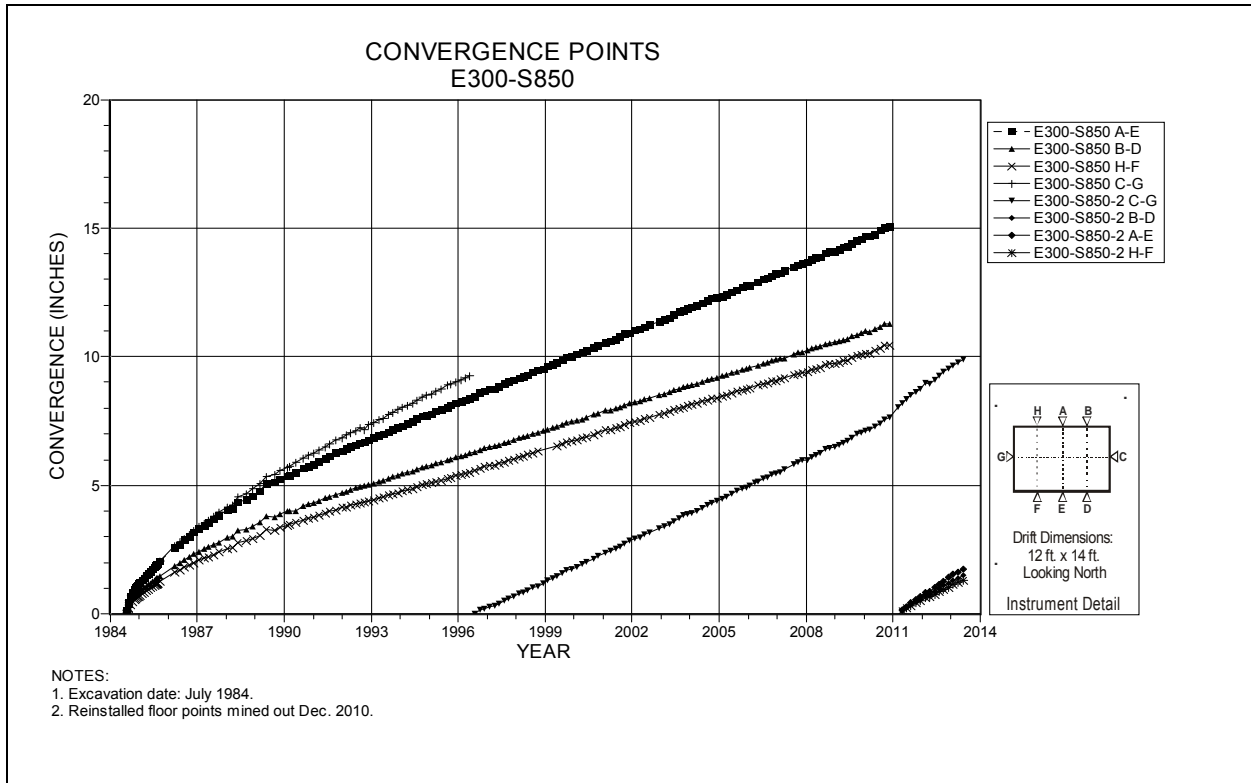

Figure 4-131 Convergence Point Array
E300 S850 – All Chords

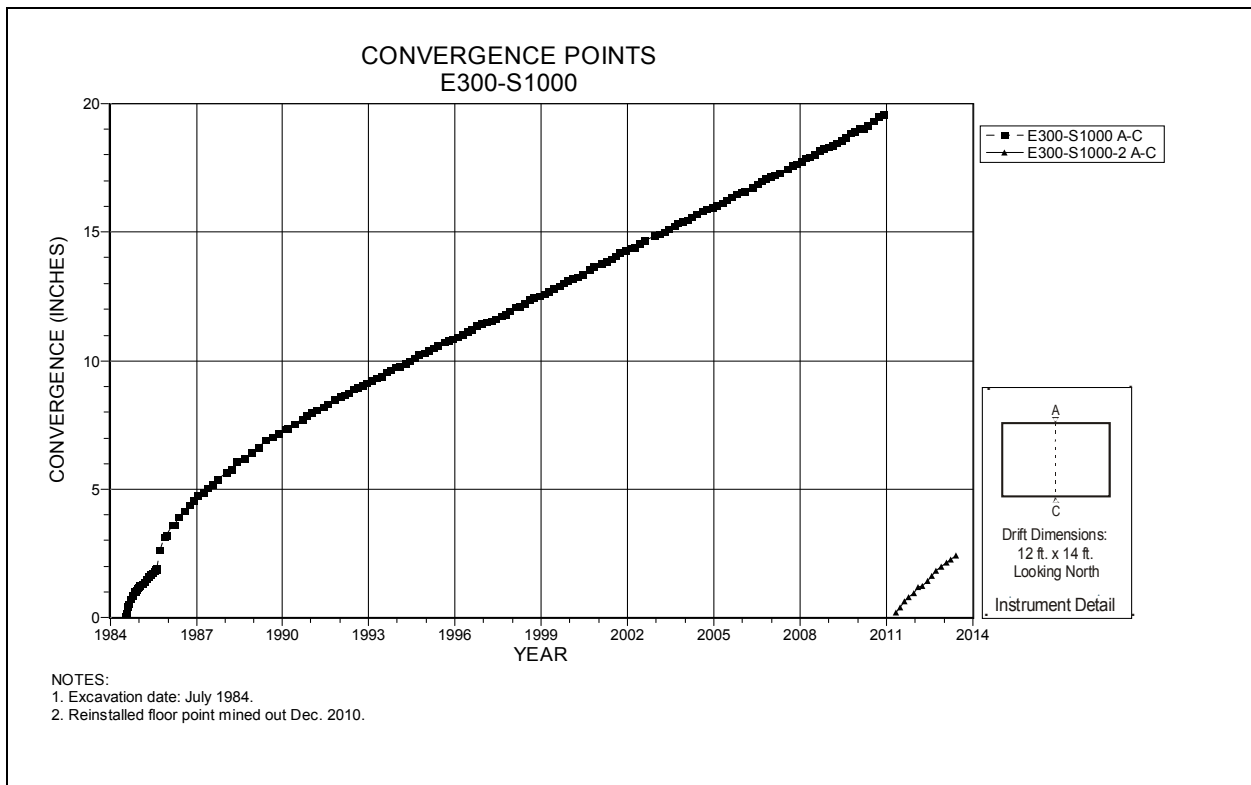
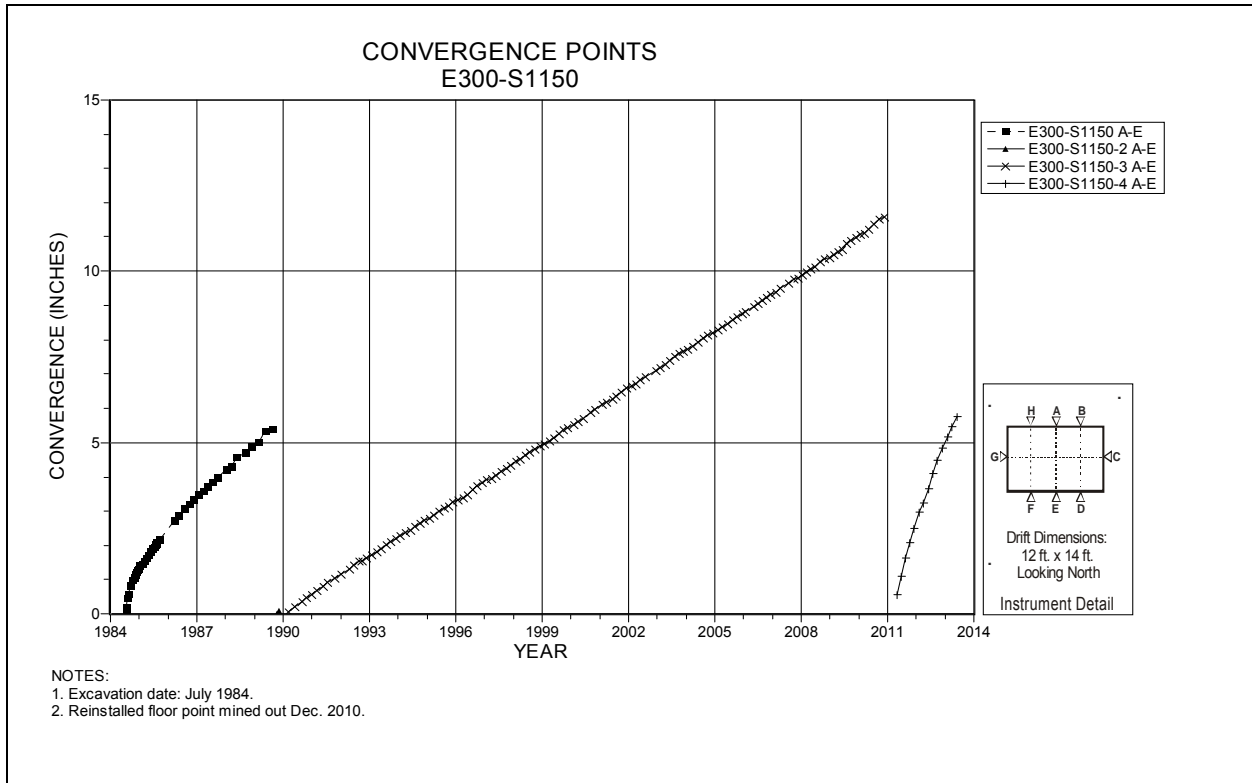
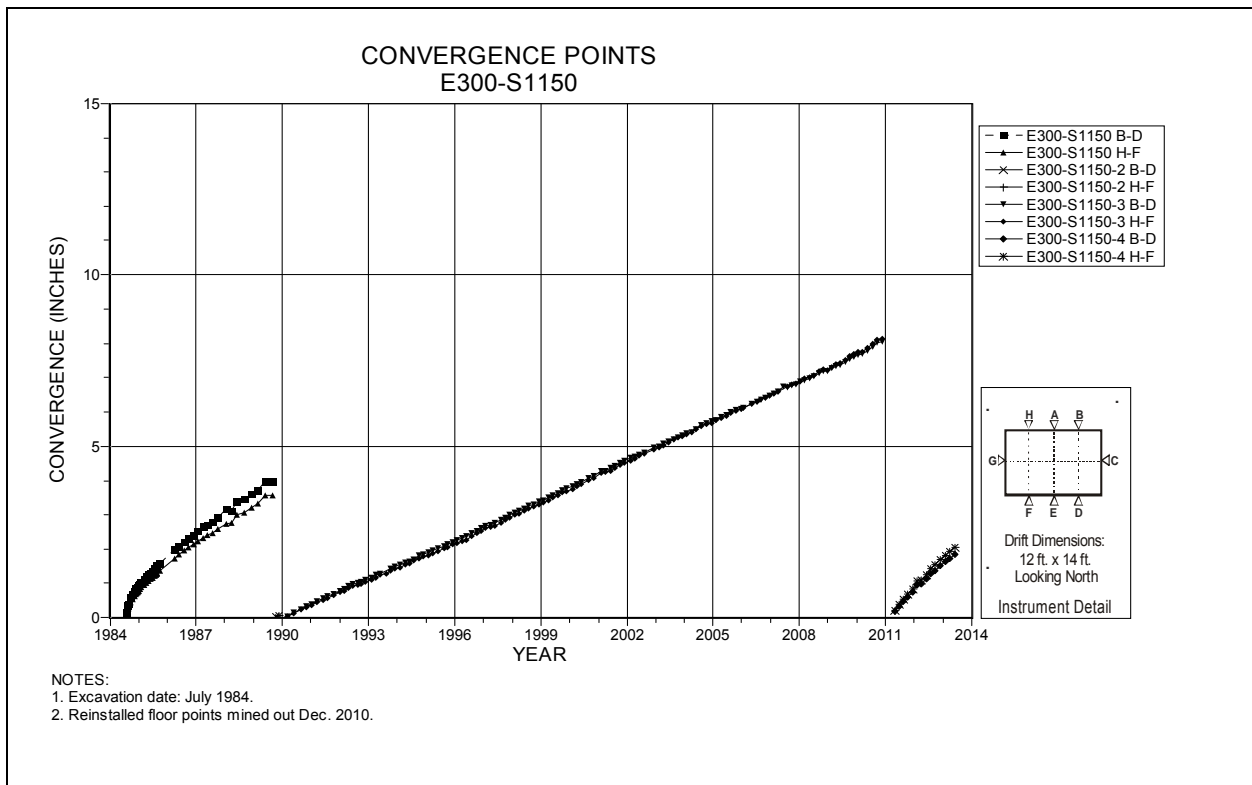

Figure 4-132 Convergence Point Array
E300 S1000 – Roof to Floor



**Figure 4-133 Convergence Point Array
E300 S1150 – Roof to Floor**



**Figure 4-134 Convergence Point Array
E300 S1150 – Roof to Floor – Quarter Points**

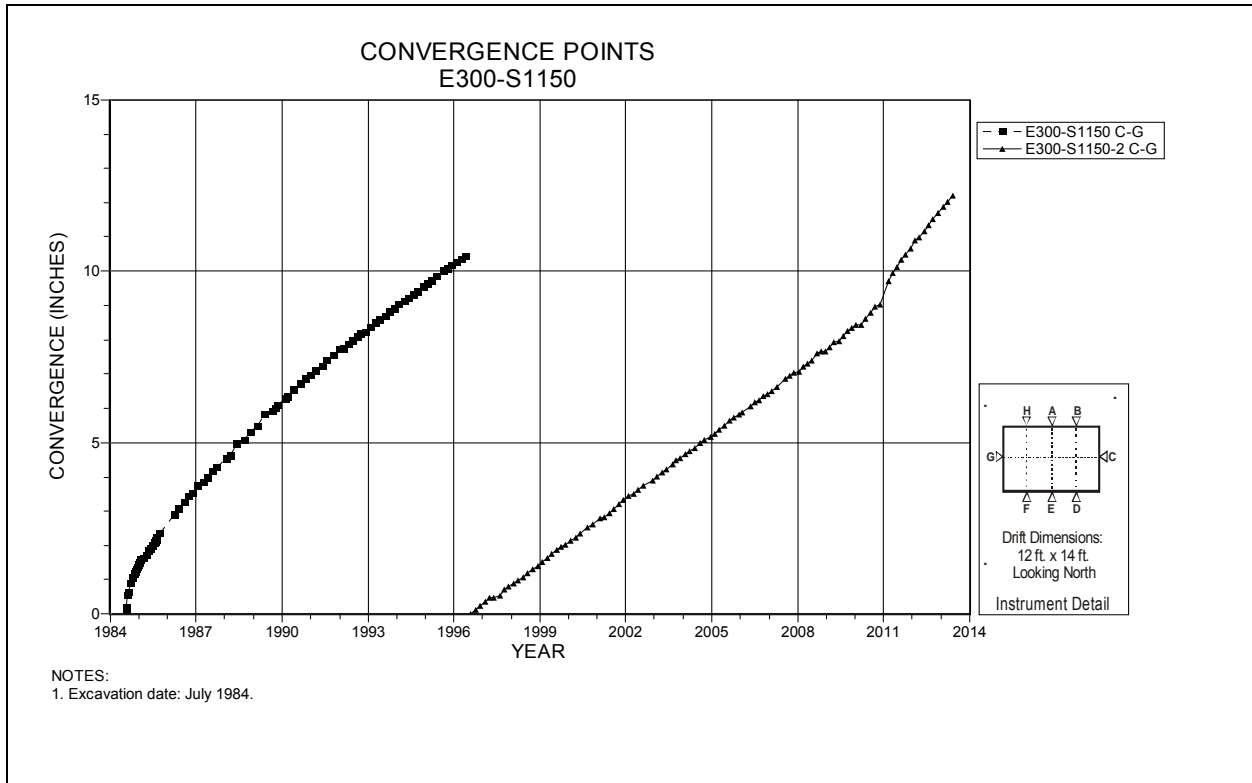

Figure 4-135 Convergence Point Array
E300 S1150 – Rib to Rib

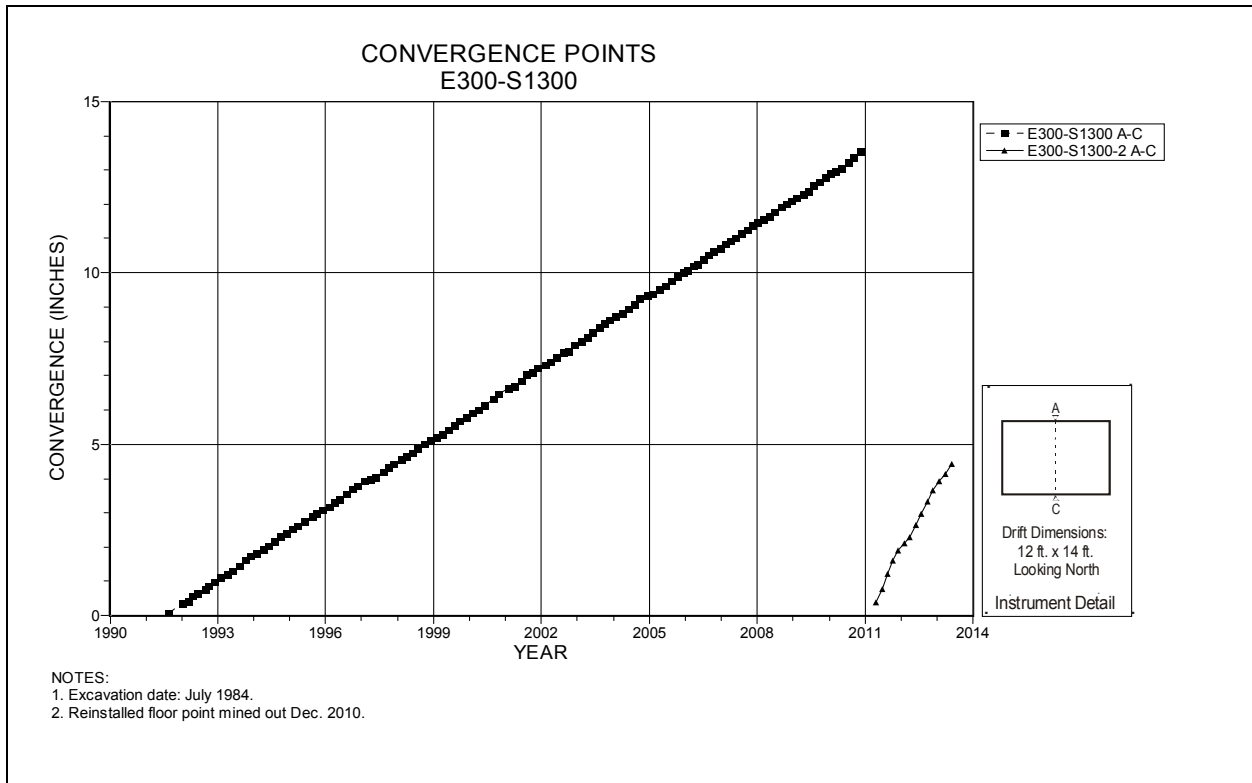

Figure 4-136 Convergence Point Array
E300 S1300 – Roof to Floor

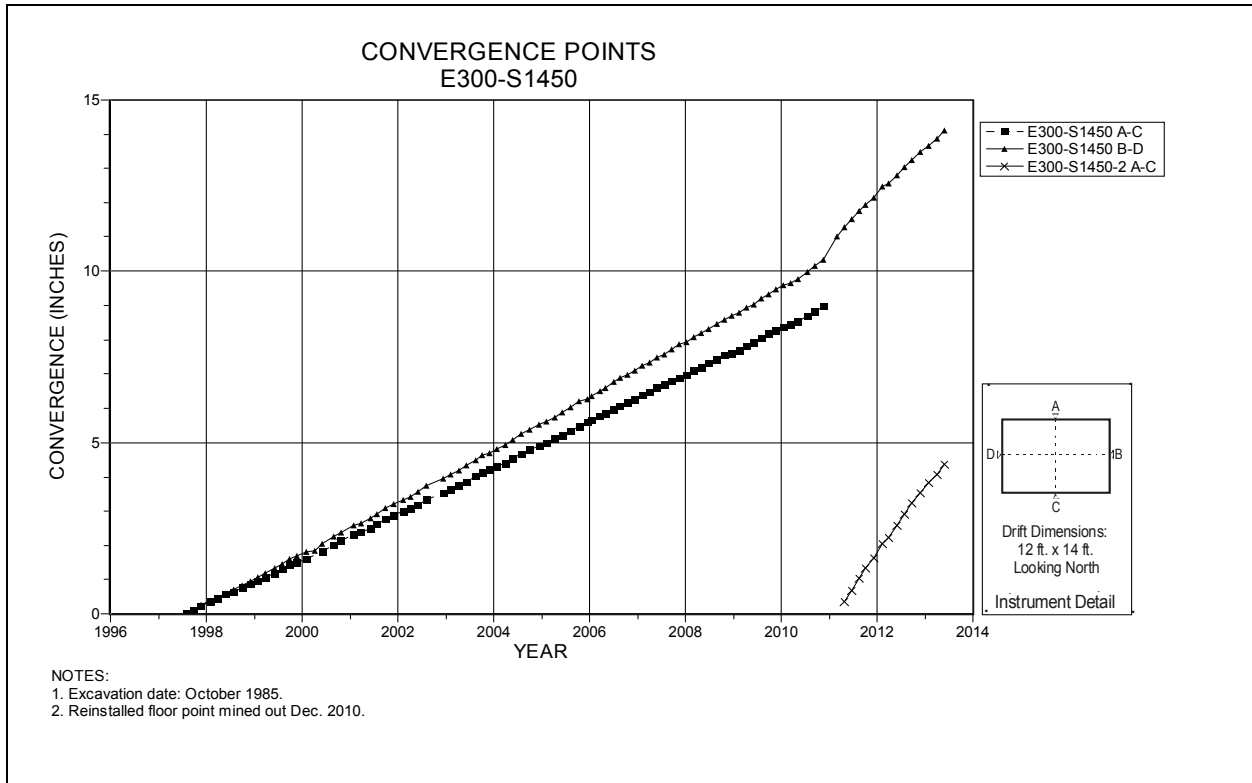

Figure 4-137 Convergence Point Array
E300 S1450 – All Chords

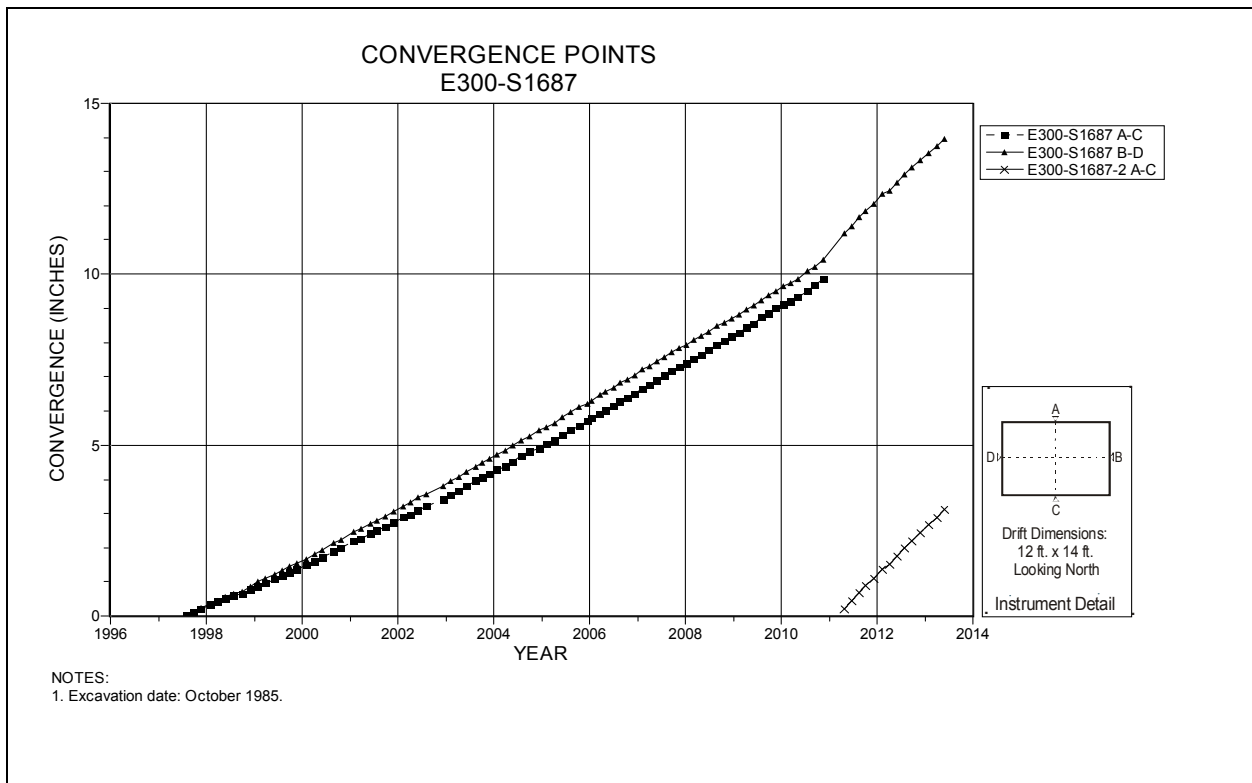

Figure 4-138 Convergence Point Array
E300 S1687 – All Chords

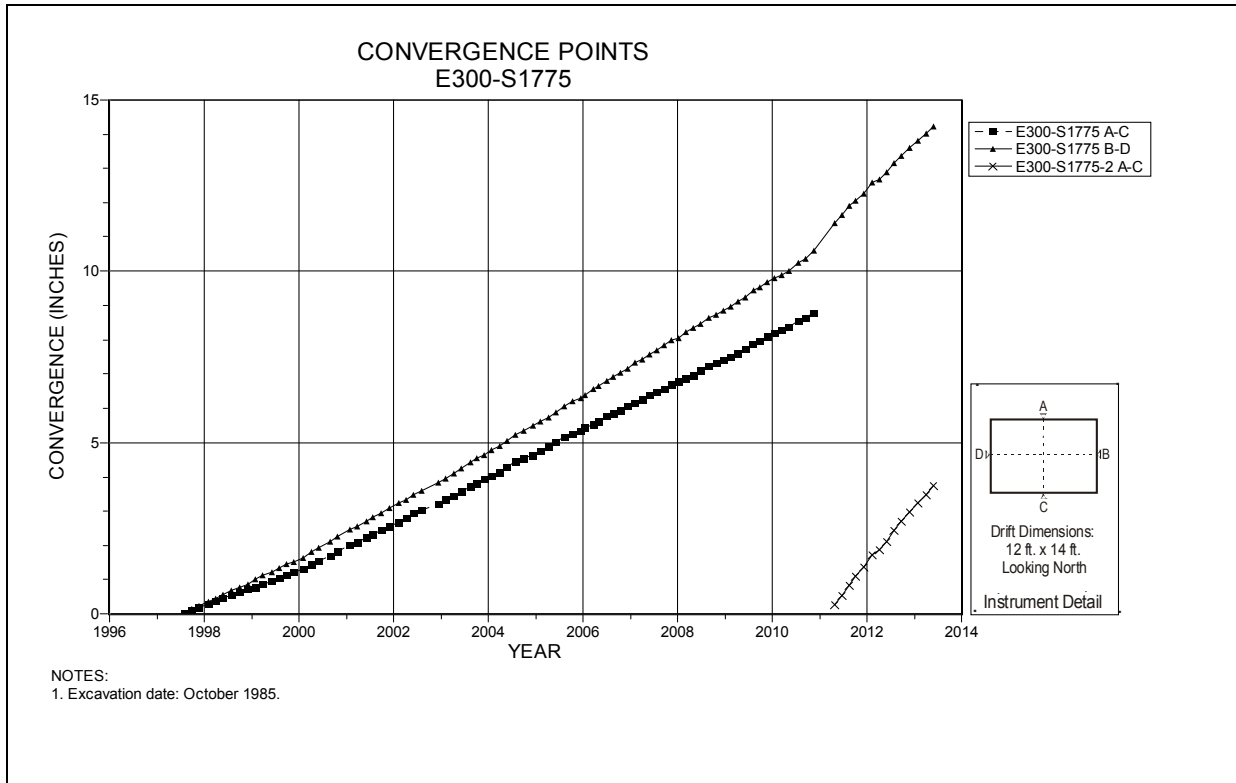

Figure 4-139 Convergence Point Array
E300 S1775 – All Chords

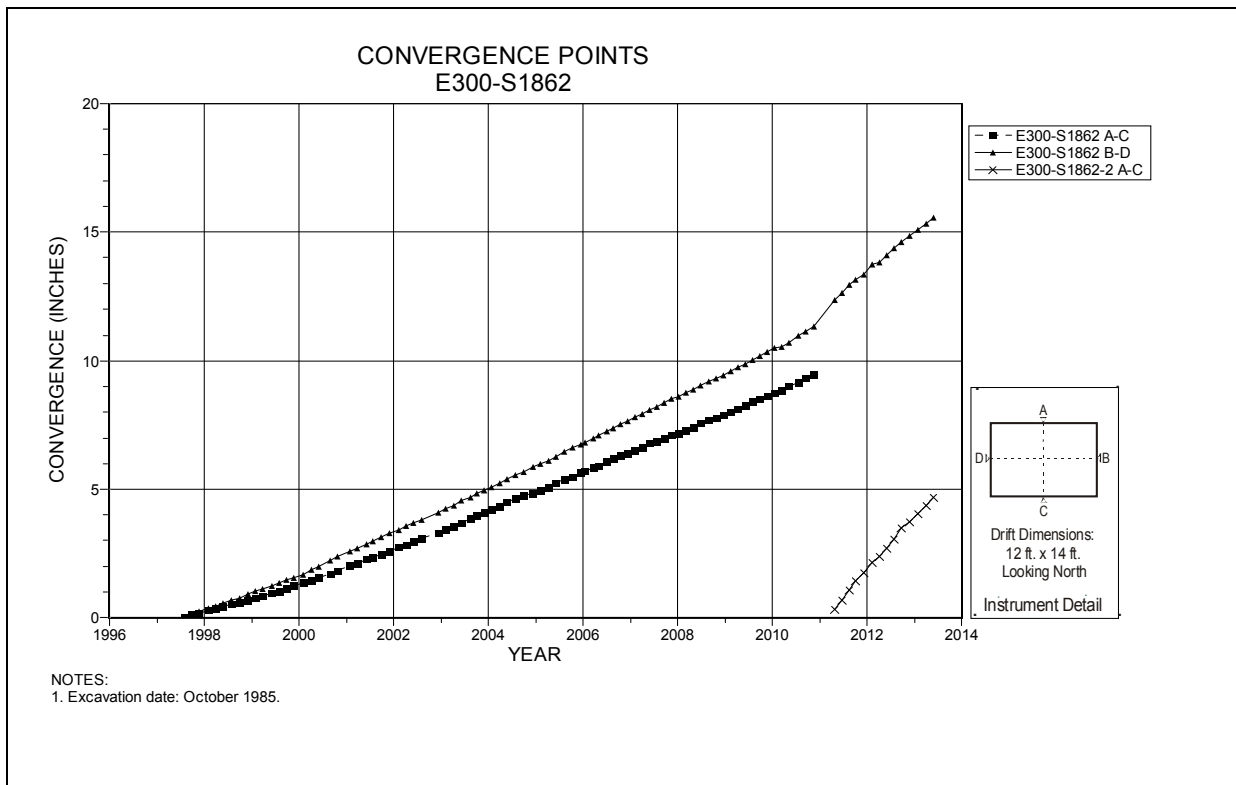

Figure 4-140 Convergence Point Array
E300 S1862 – All Chords

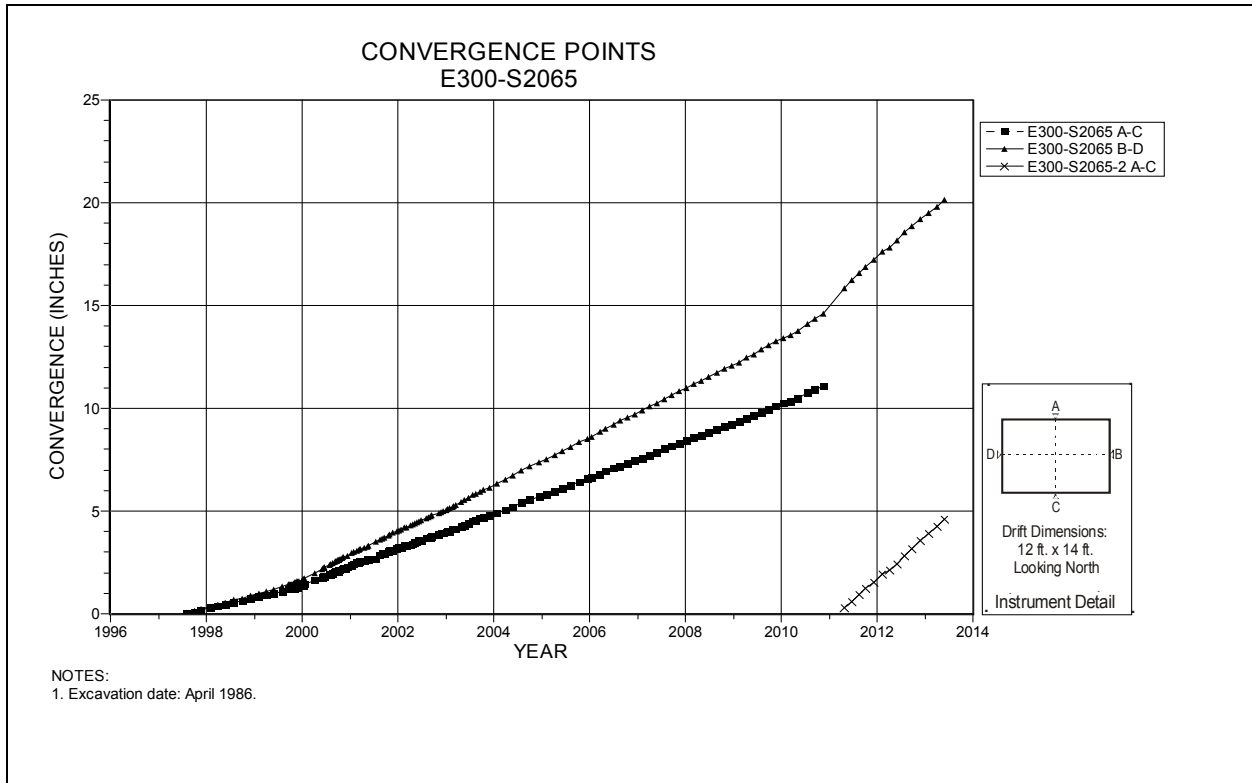

Figure 4-141 Convergence Point Array
E300 S2065 – All Chords

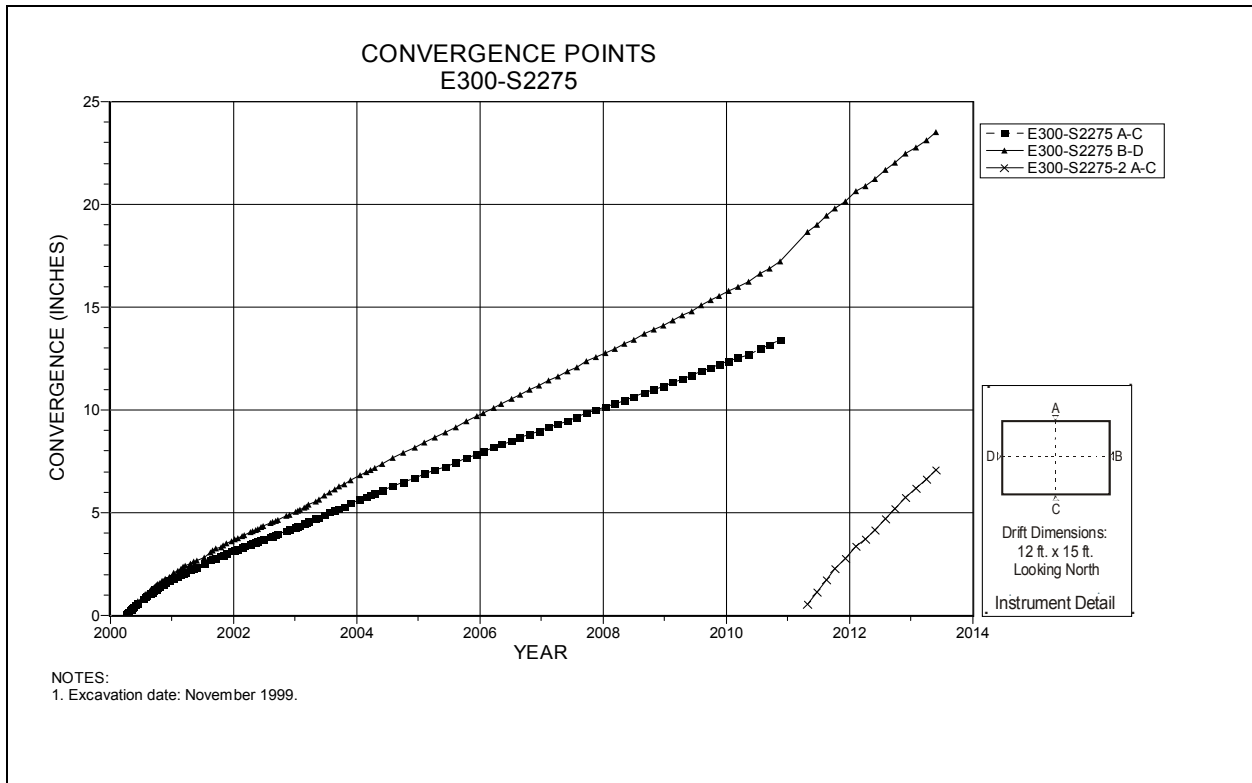

Figure 4-142 Convergence Point Array
E300 S2275 – All Chords

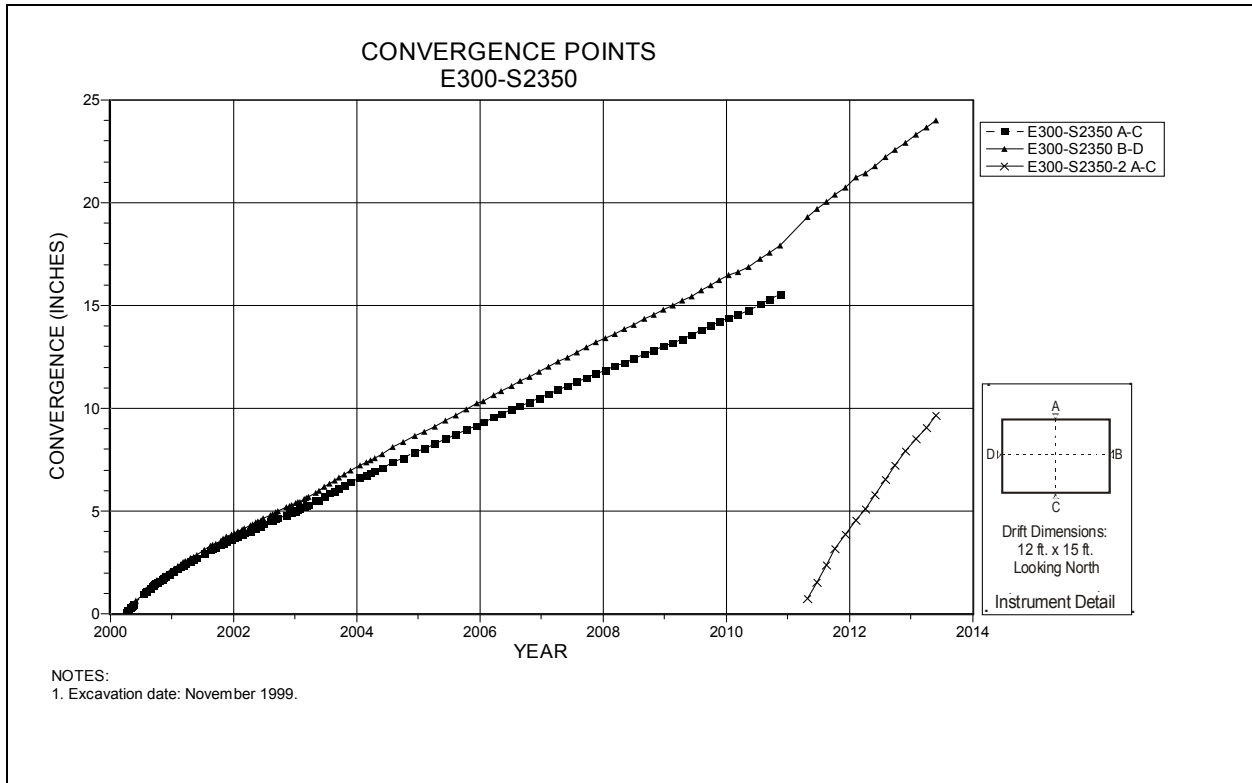

Figure 4-143 Convergence Point Array
E300 S2350 – All Chords

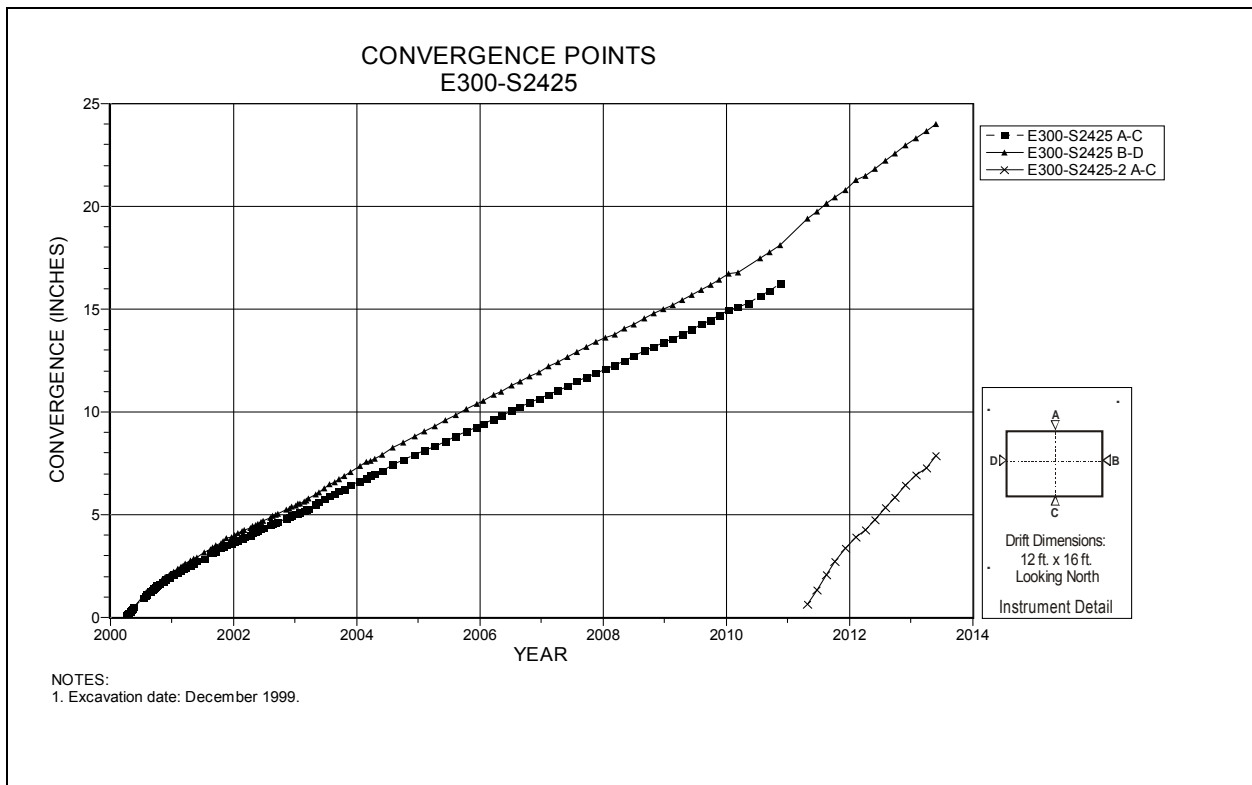

Figure 4-144 Convergence Point Array
E300 S2425 – All Chords

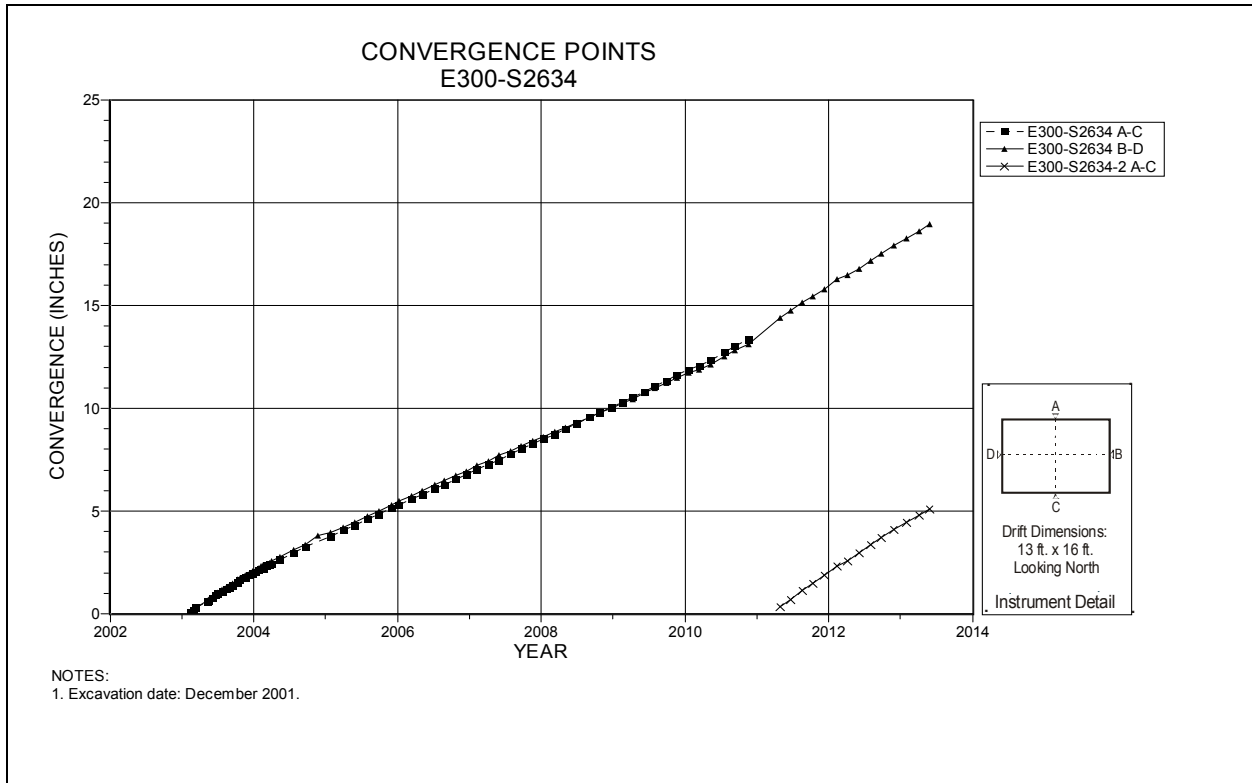

Figure 4-145 Convergence Point Array
E300 S2634 – All Chords

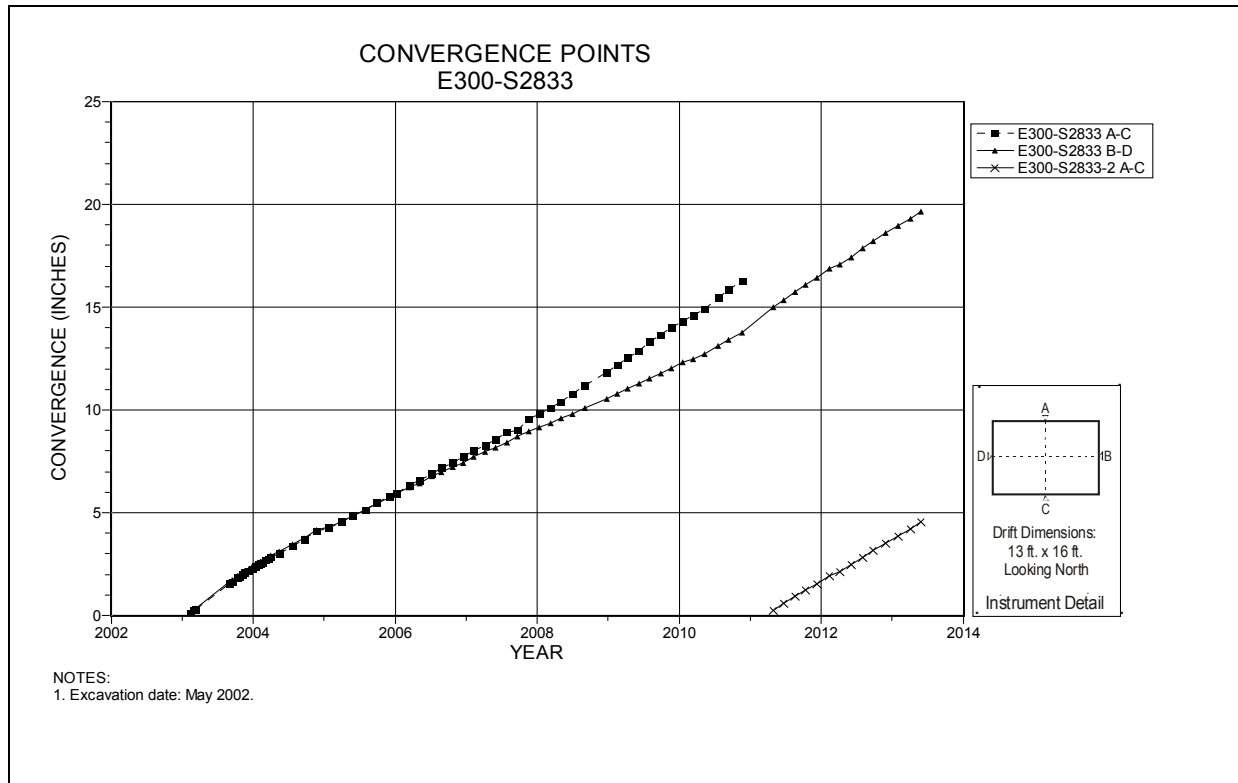
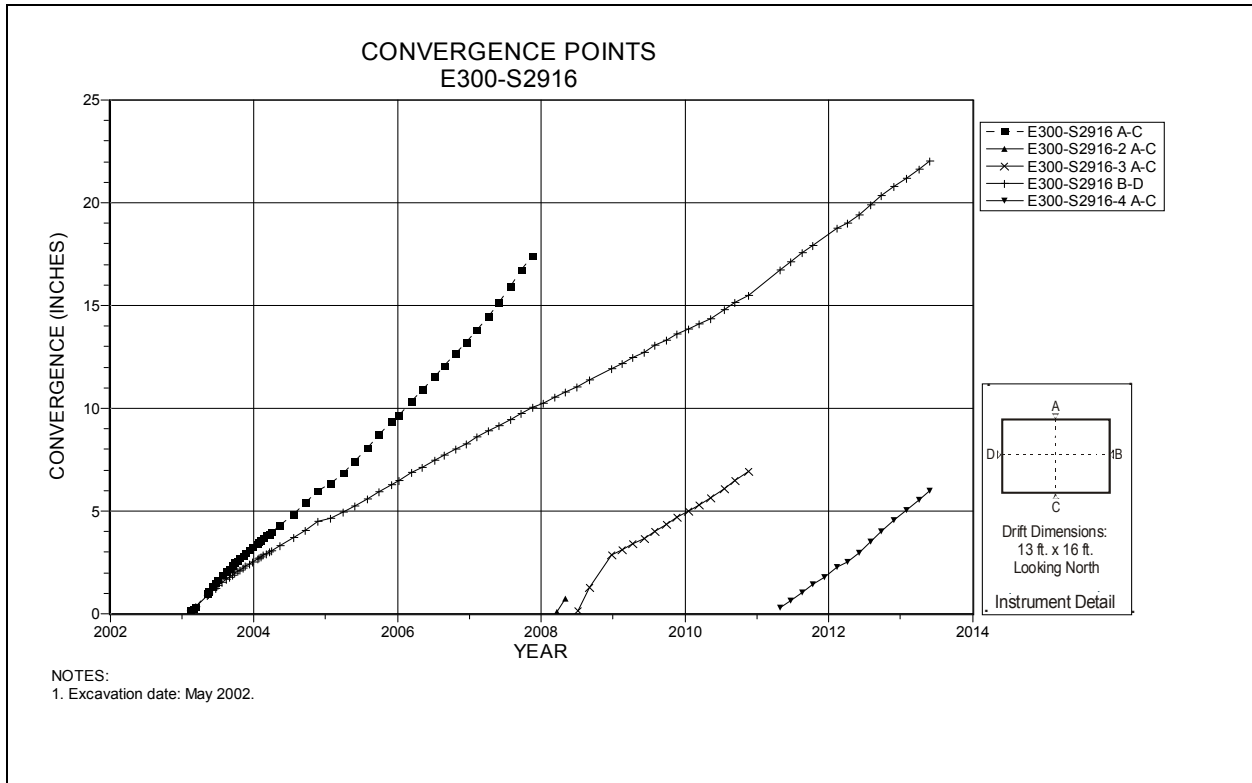
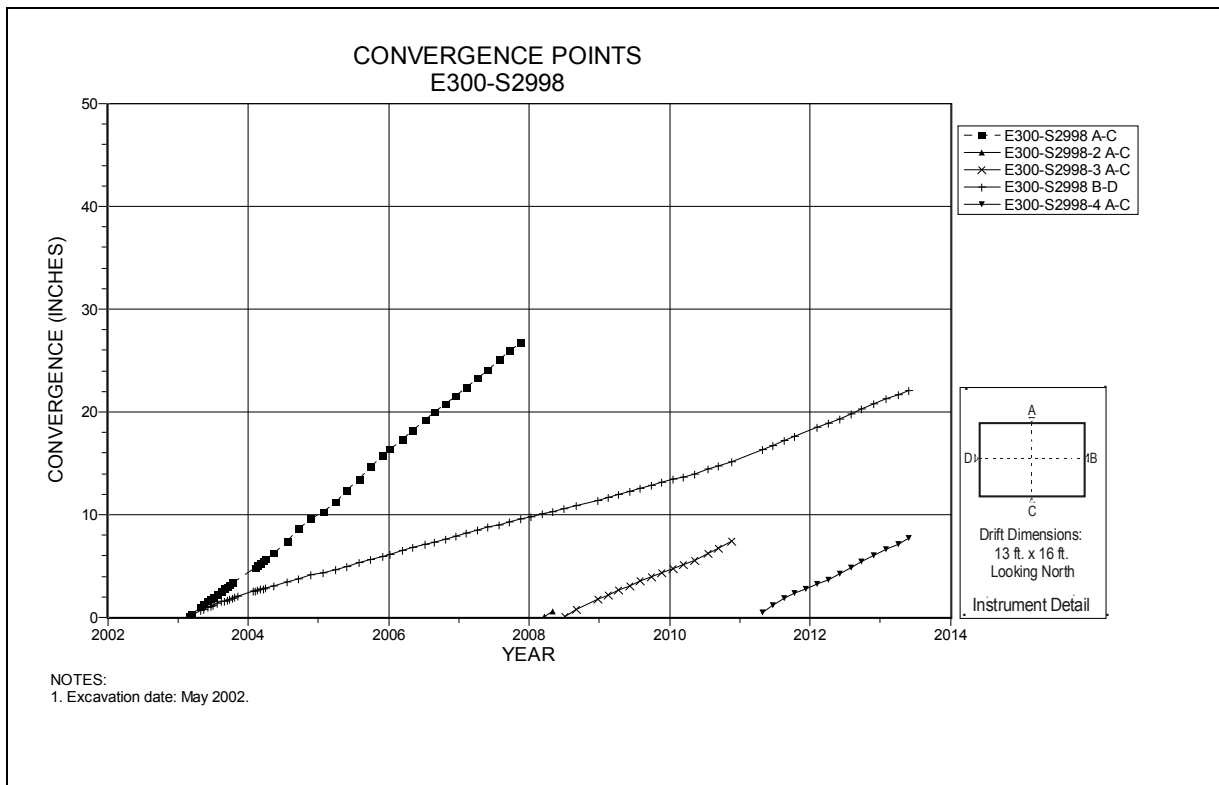

Figure 4-146 Convergence Point Array
E300 S2833 – All Chords



**Figure 4-147 Convergence Point Array
E300 S2916 – All Chords**



**Figure 4-148 Convergence Point Array
E300 S2998 – All Chords**

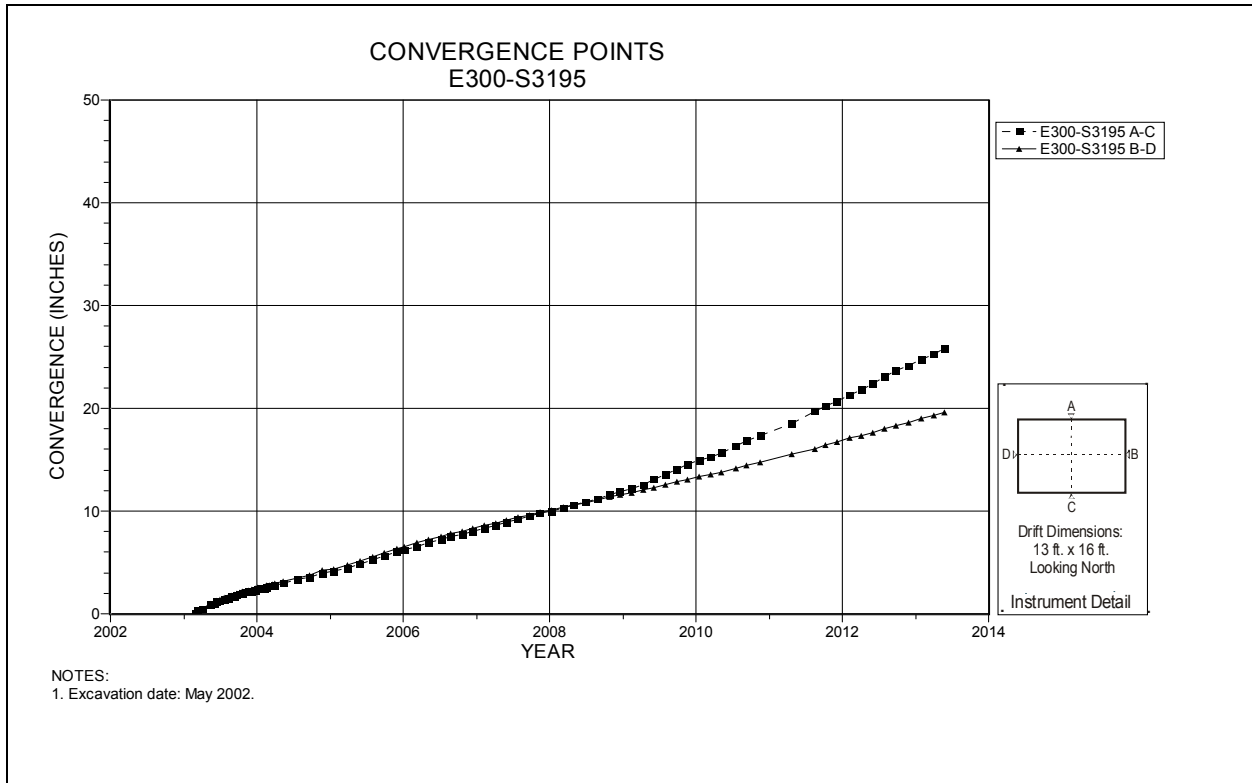

Figure 4-149 Convergence Point Array
E300 S3195 – All Chords

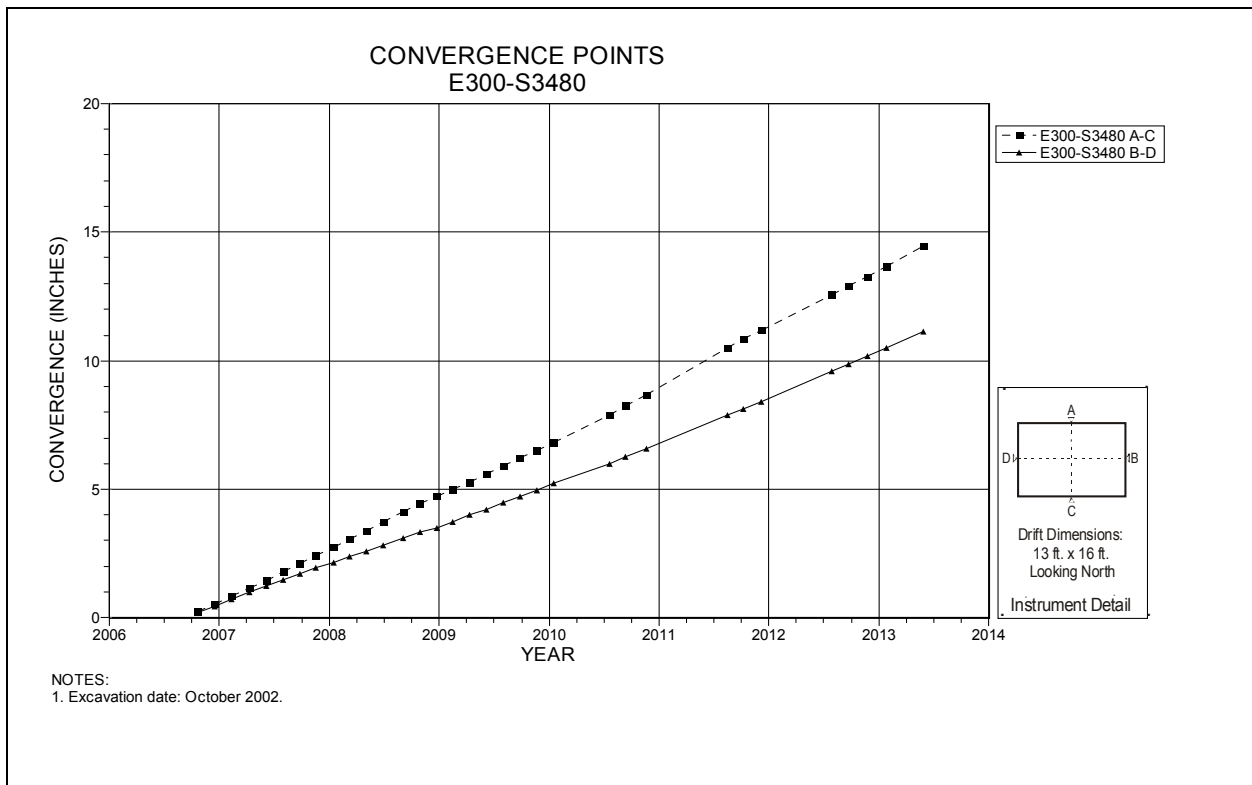

Figure 4-150 Convergence Point Array
E300 S3480 – All Chords

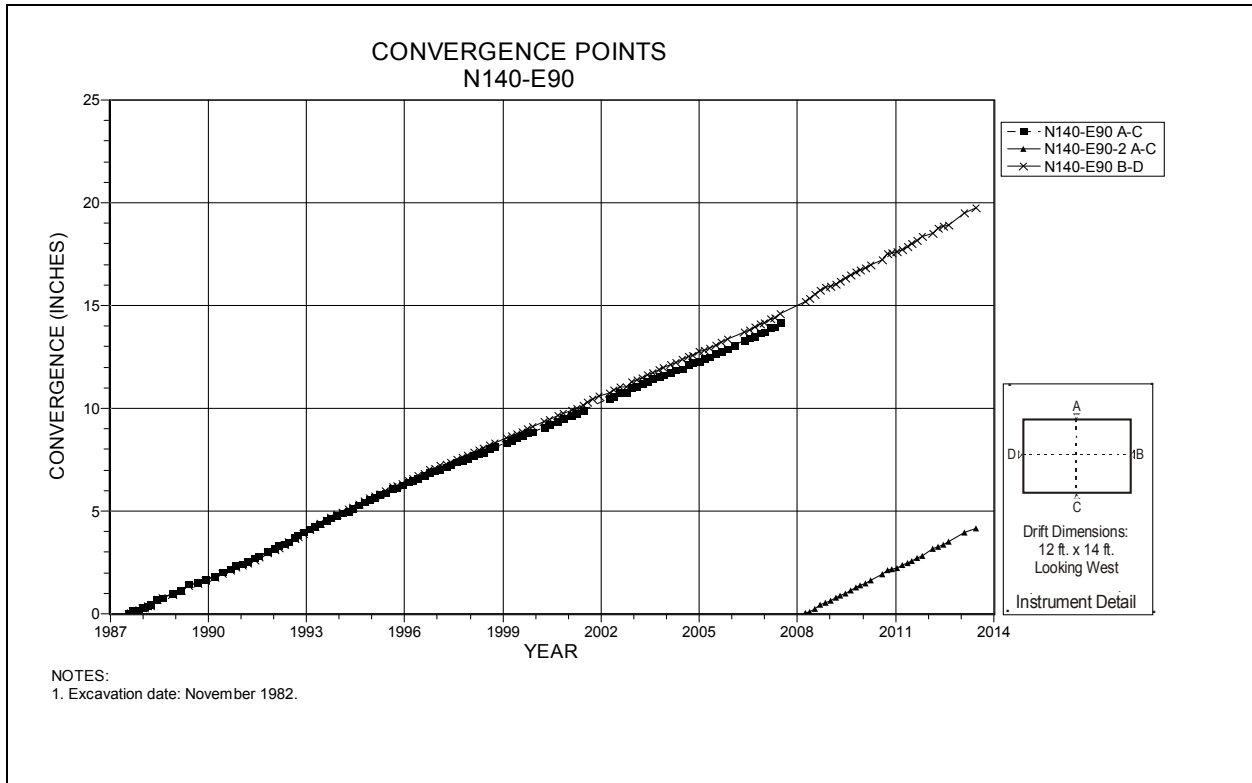

Figure 4-151 Convergence Point Array
N140 E90 – All Chords

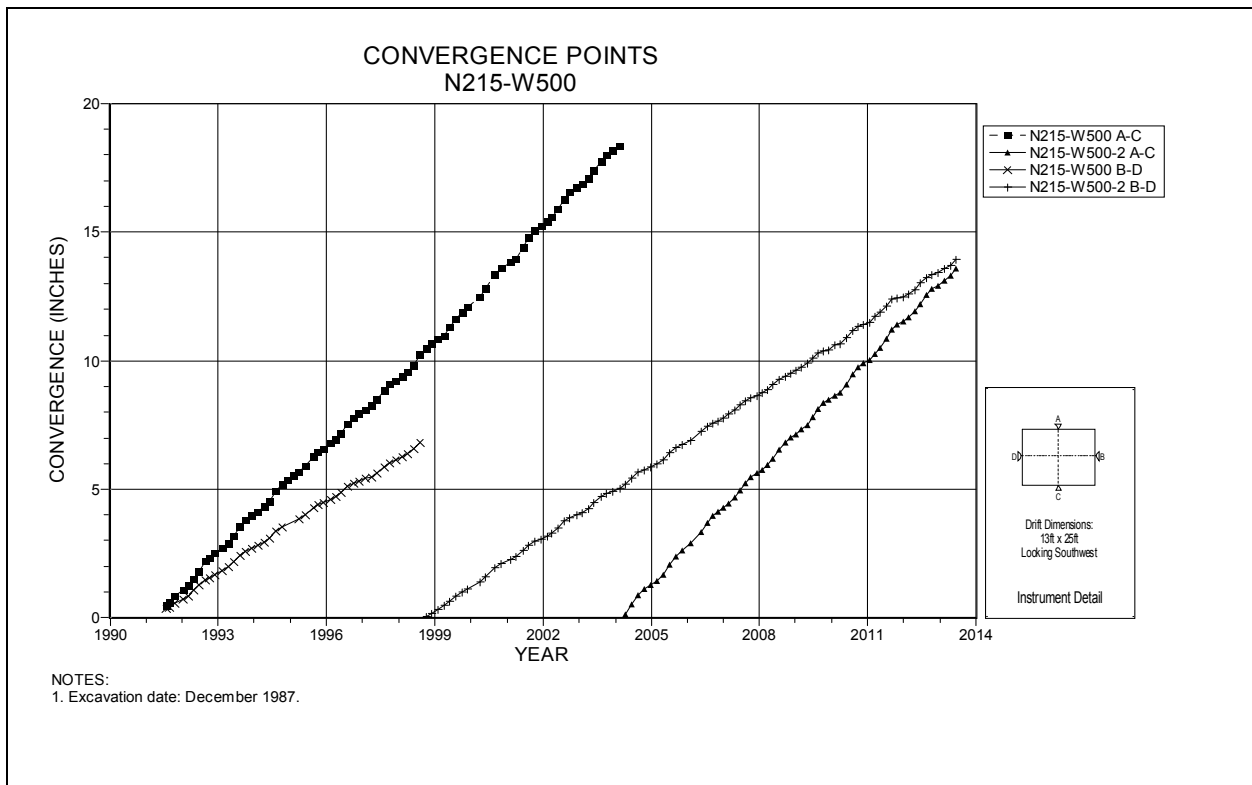

Figure 4-152 Convergence Point Array
N215 W500 – All Chords

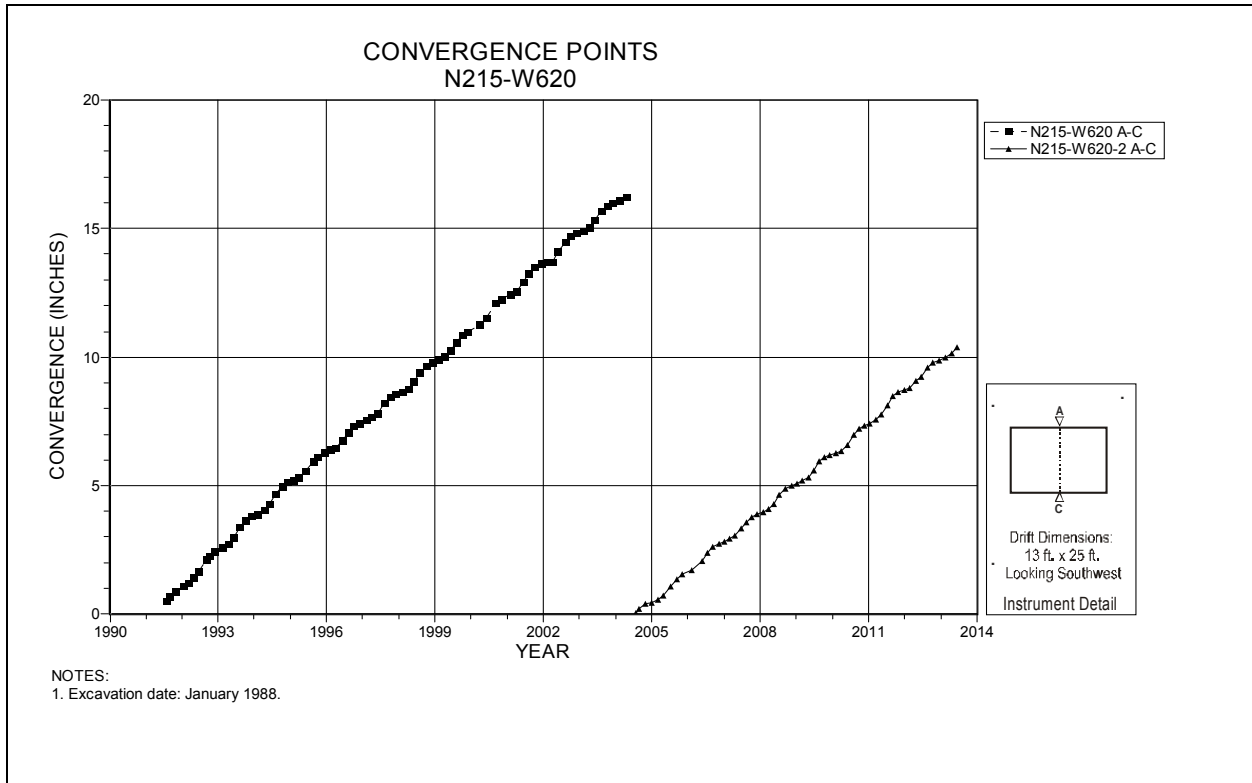

Figure 4-153 Convergence Point Array
N215 W620 – Roof to Floor

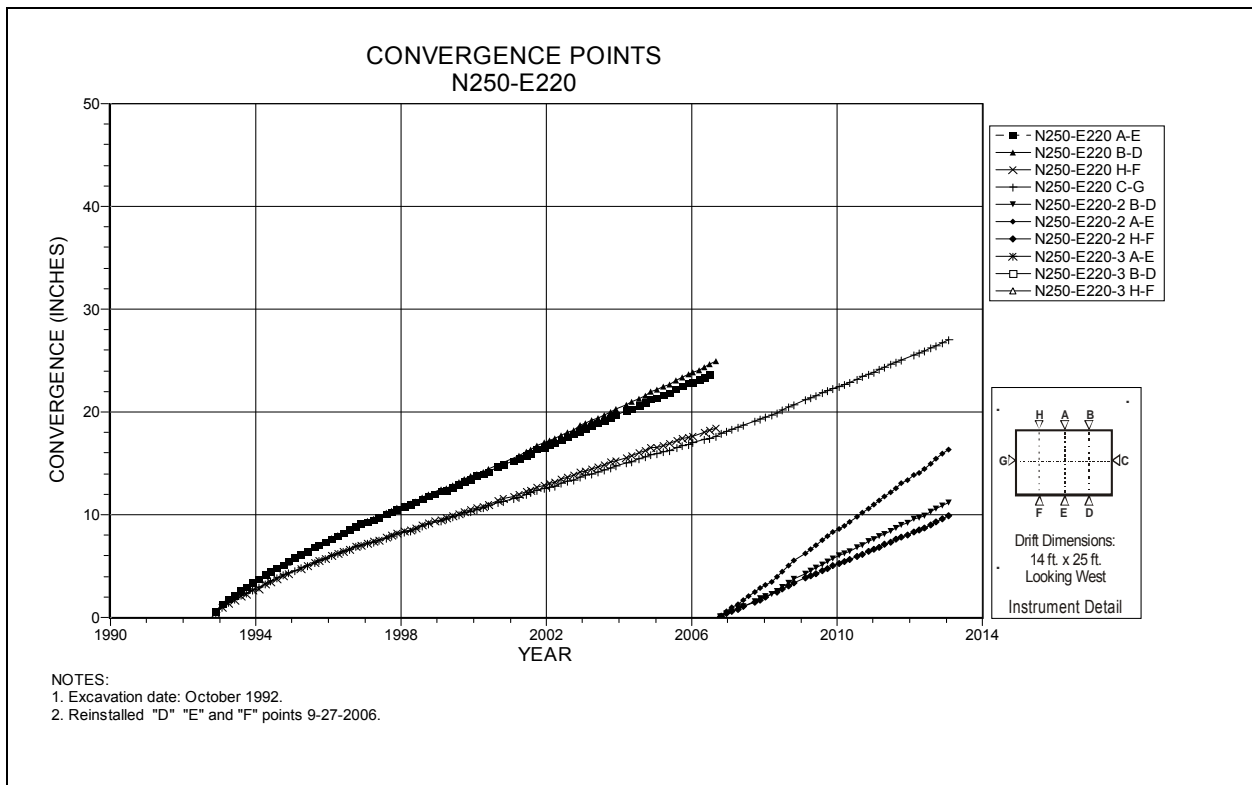

Figure 4-154 Convergence Point Array
N250 E220 – All Chords

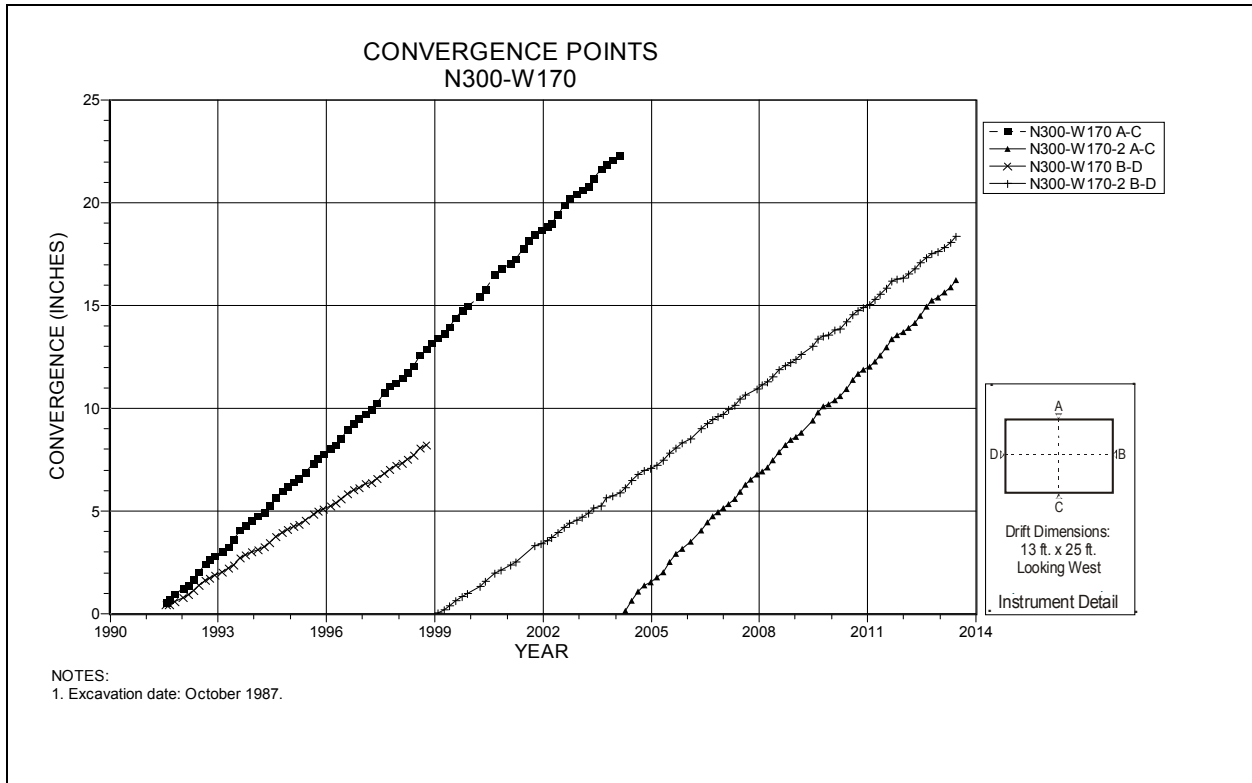

Figure 4-155 Convergence Point Array
N300 W170 – All Chords

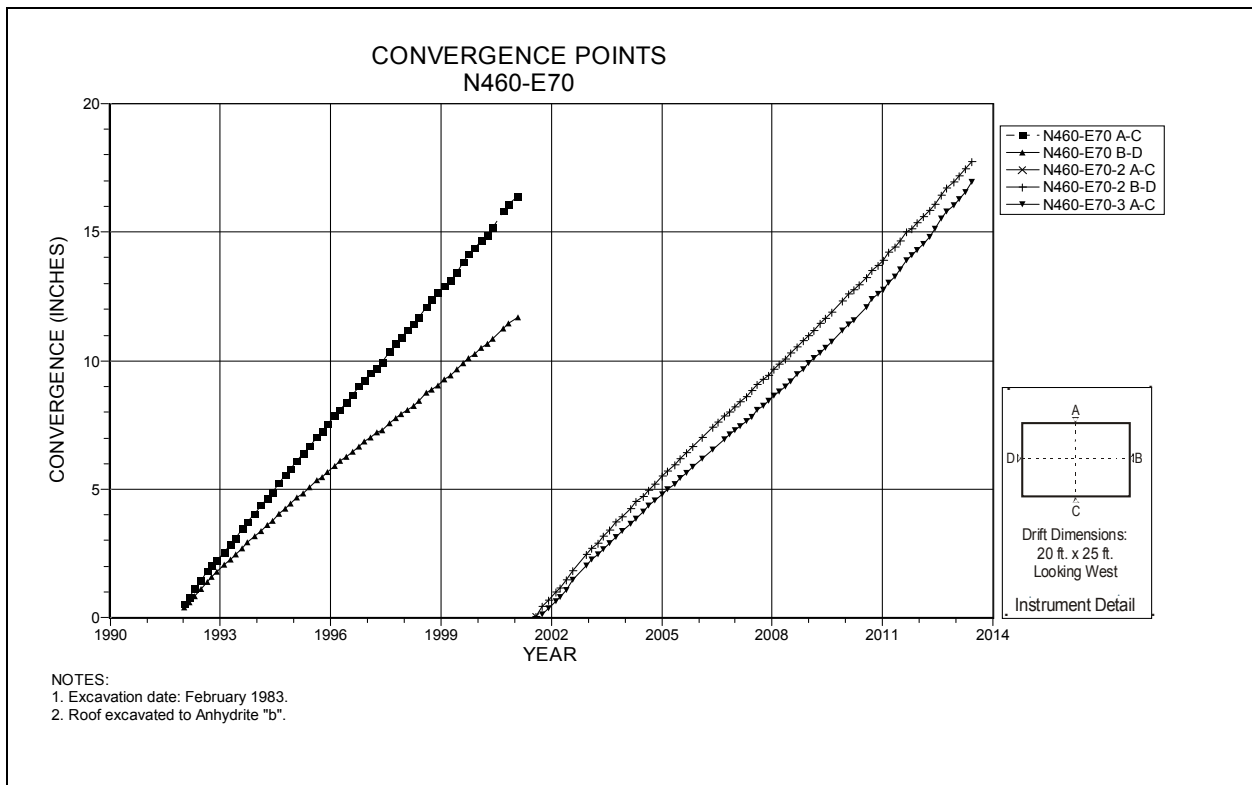

Figure 4-156 Convergence Point Array
N460 E70 – All Chords

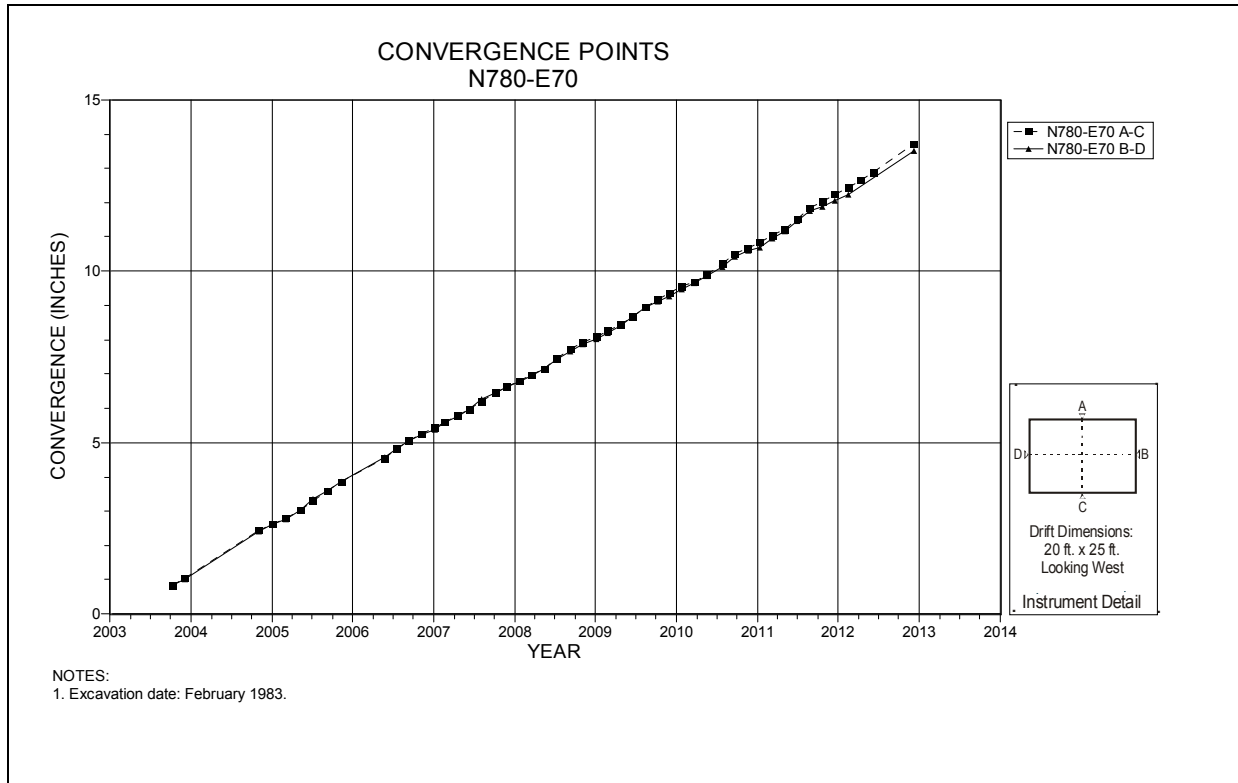

Figure 4-157 Convergence Point Array
N780 E70 – All Chords

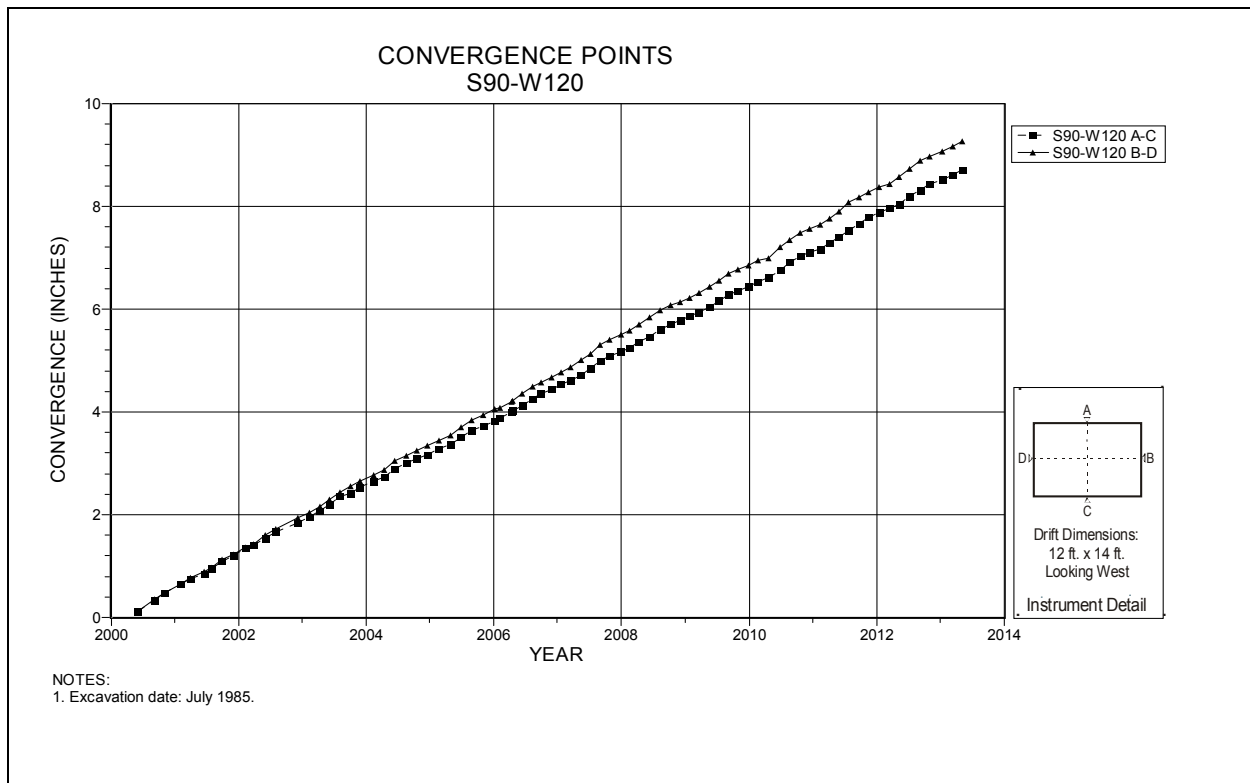

Figure 4-158 Convergence Point Array
S90 W120 – All Chords

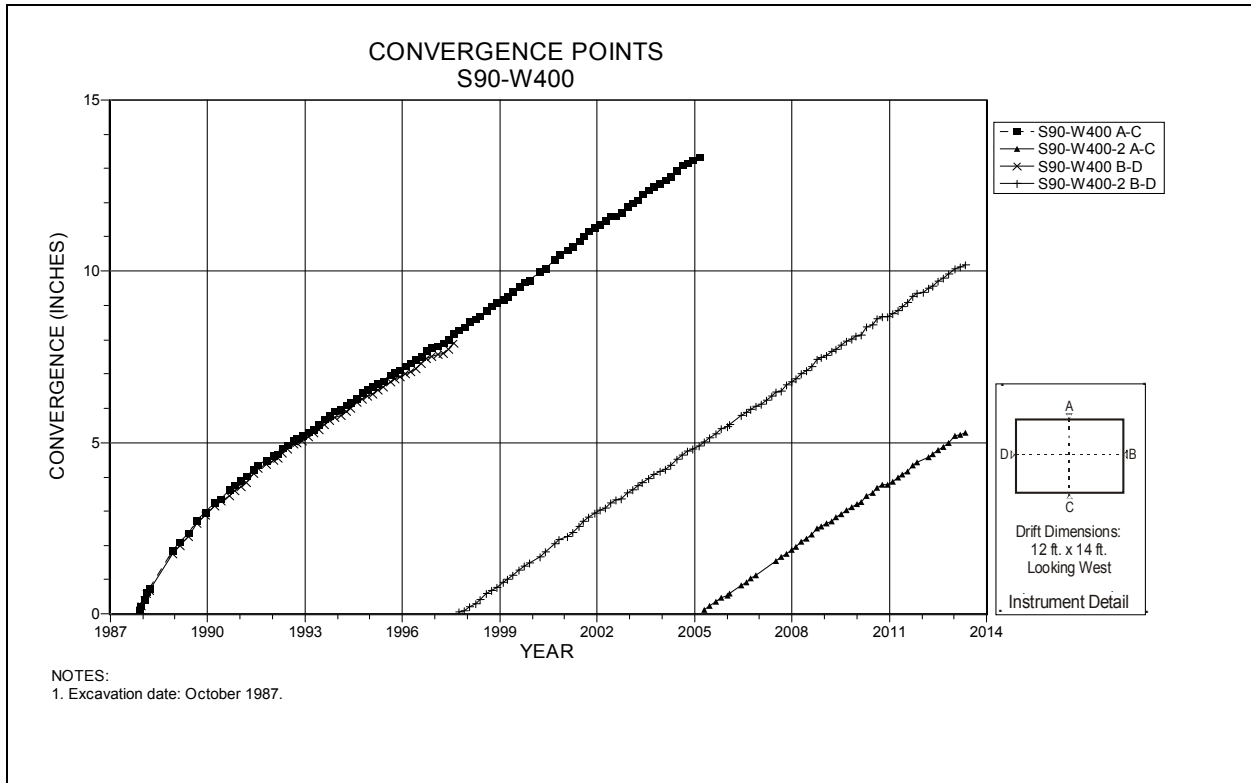

Figure 4-159 Convergence Point Array
S90 W400 – All Chords

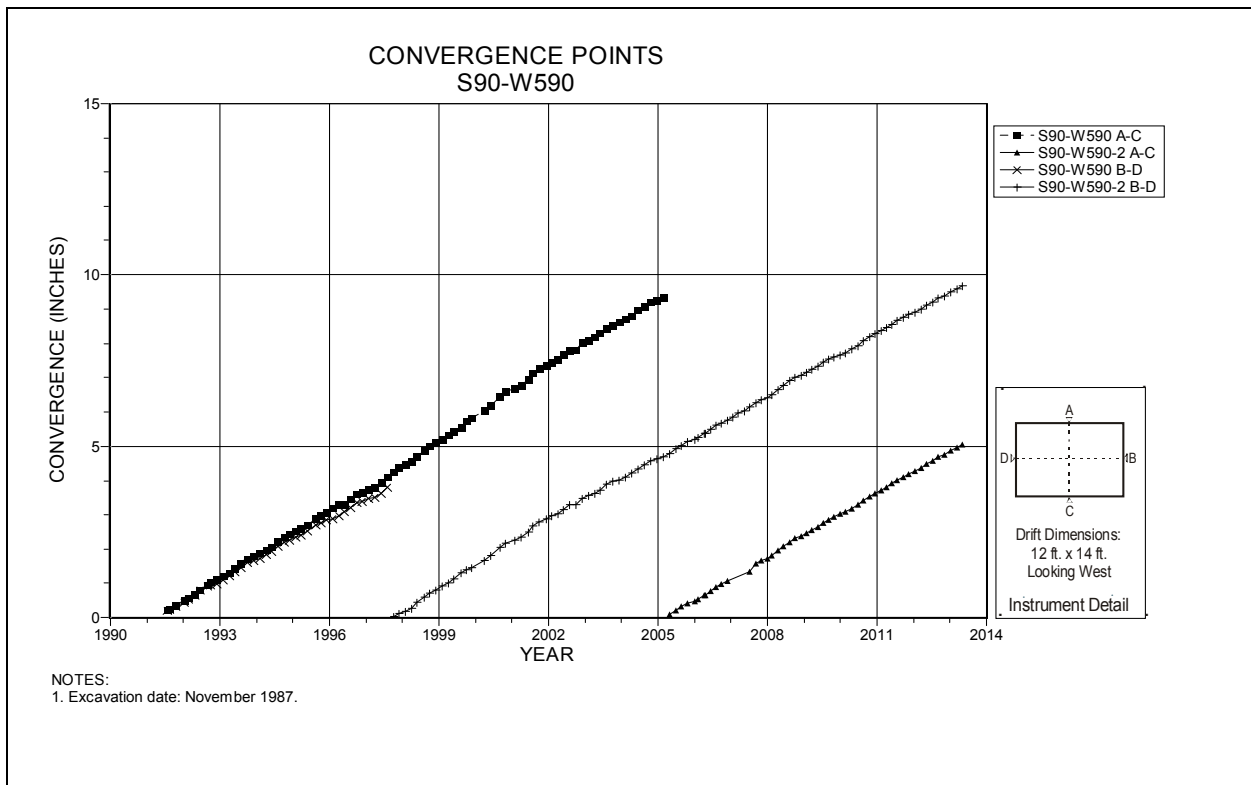

Figure 4-160 Convergence Point Array
S90 W590 – All Chords

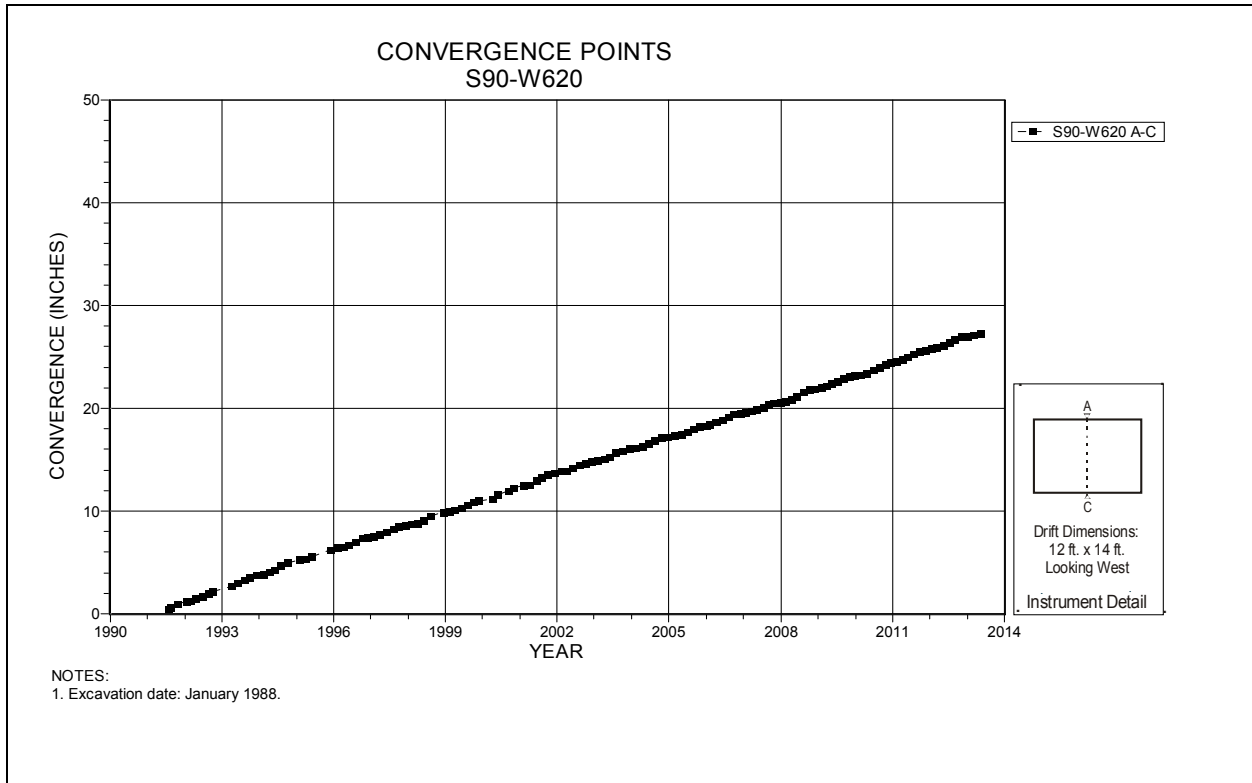

Figure 4-161 Convergence Point Array
S90 W620 – Roof to Floor

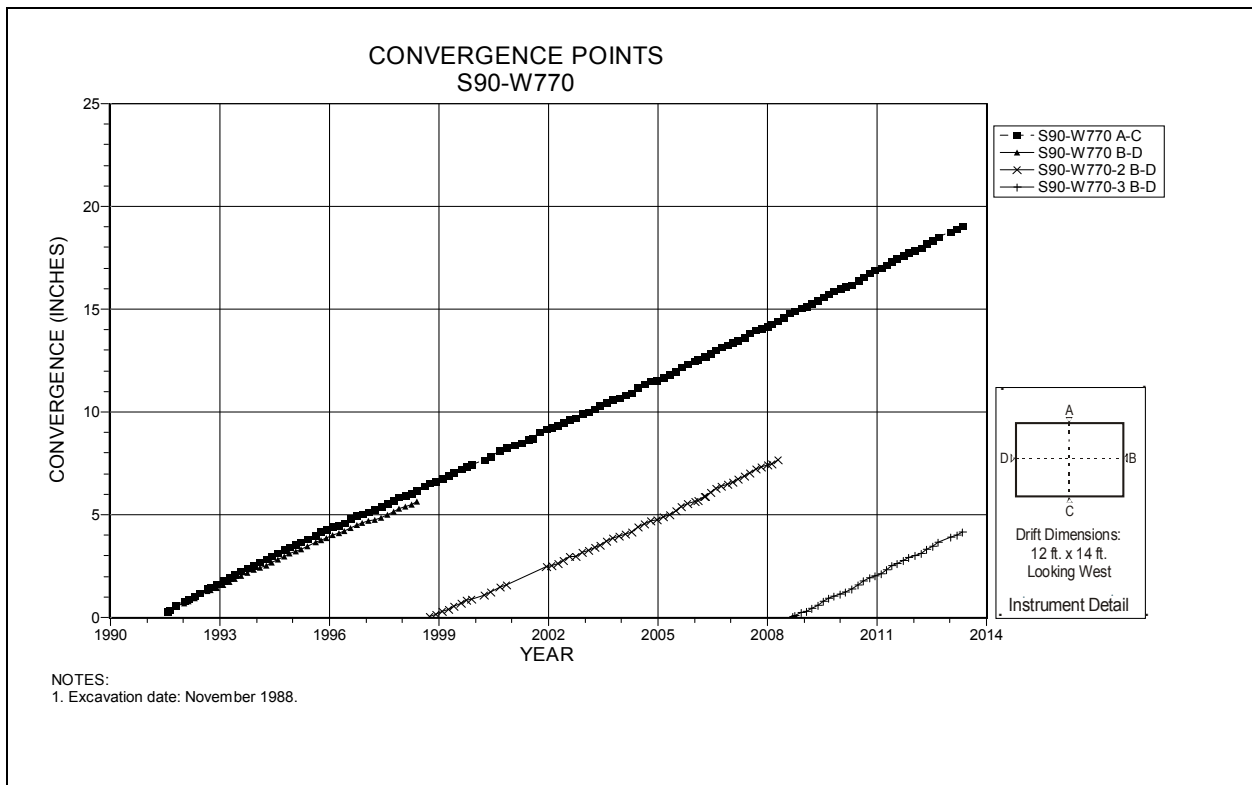

Figure 4-162 Convergence Point Array
S90 W770 – All Chords

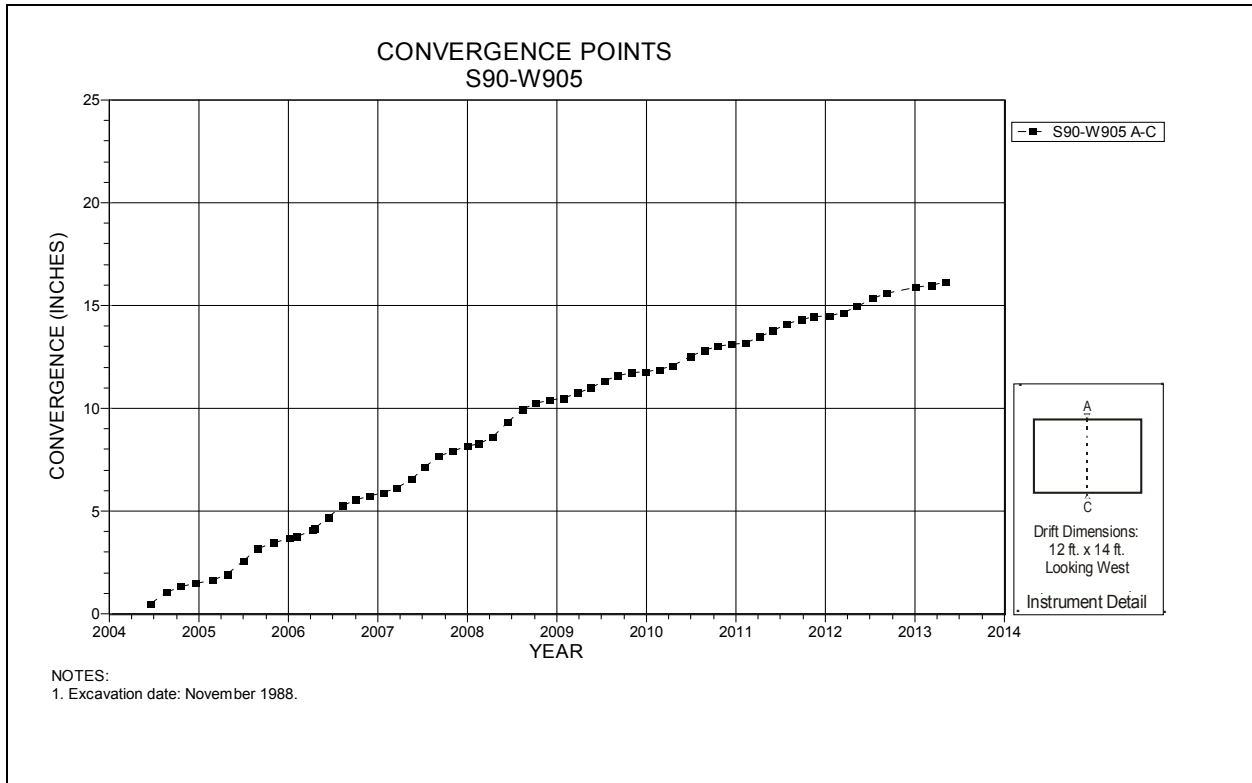

Figure 4-163 Convergence Point Array
S90 W905 – Roof to Floor

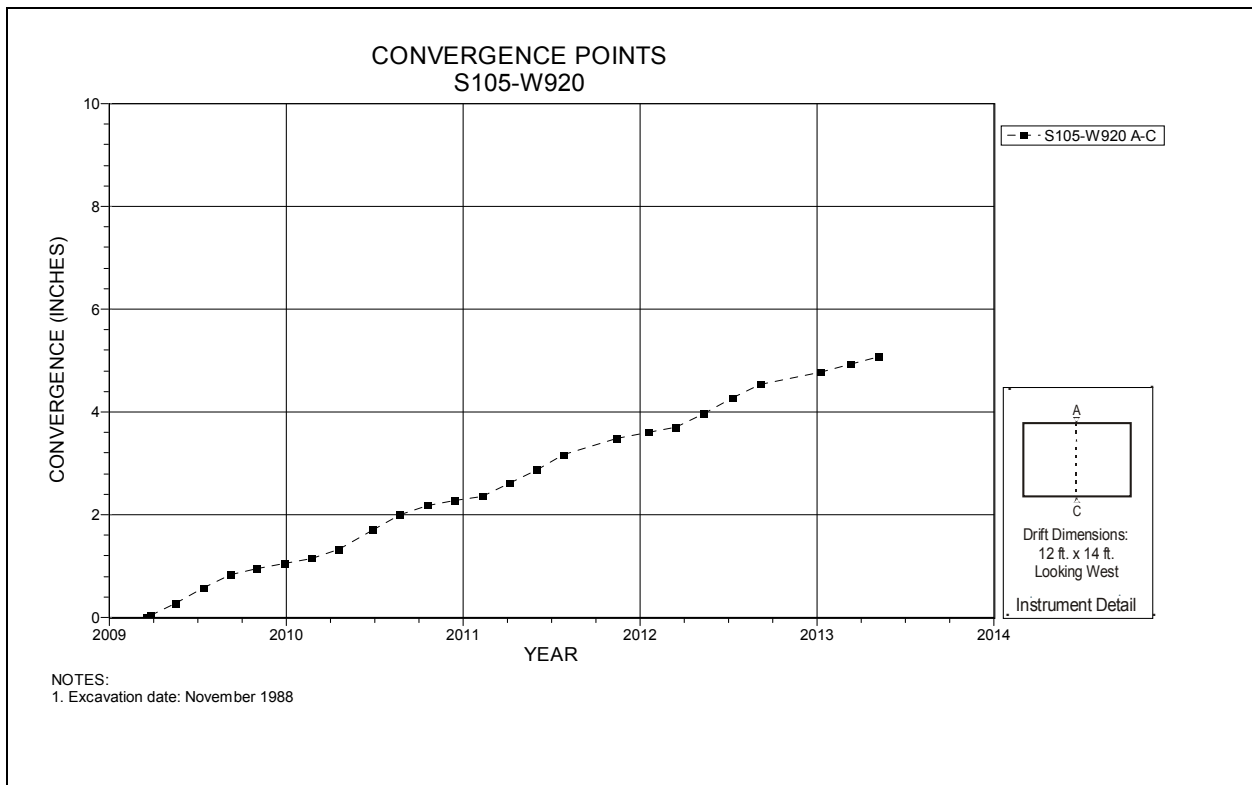

Figure 4-164 Convergence Point Array
S105 W920 – Roof to Floor

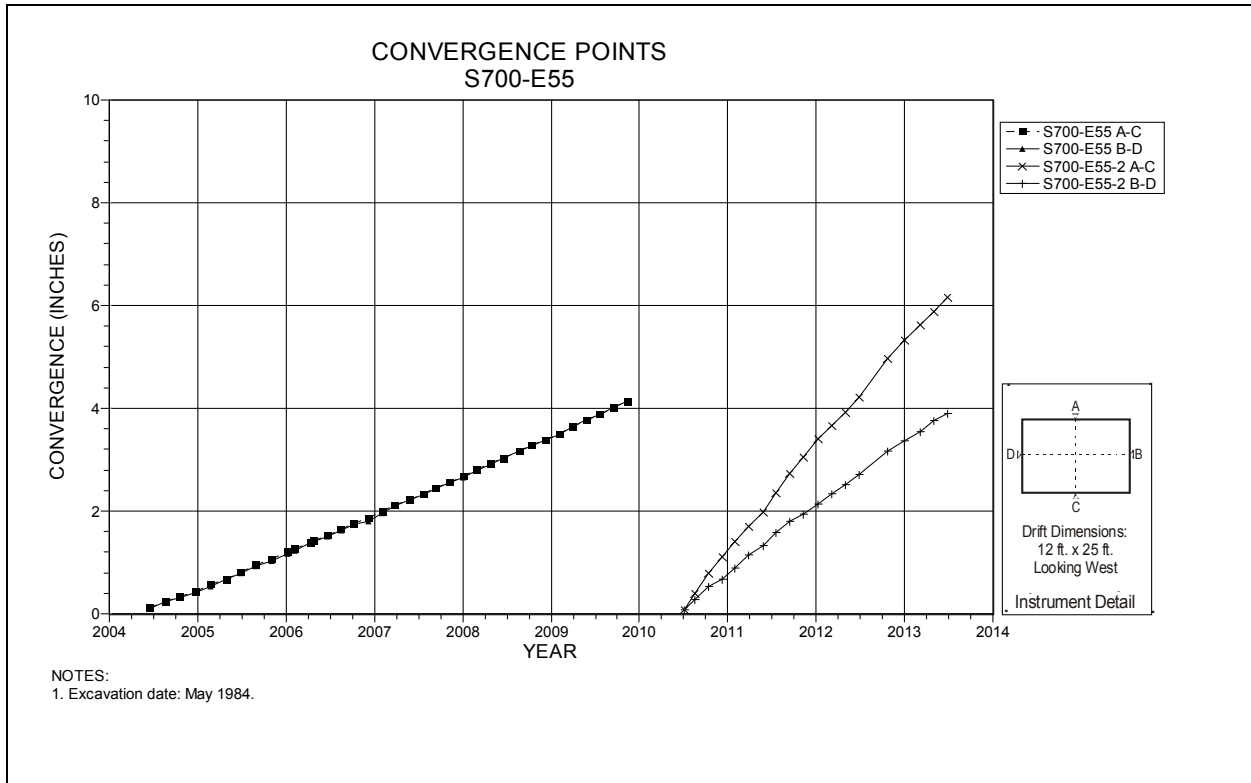

Figure 4-165 Convergence Point Array
S700 E55 – All Chords

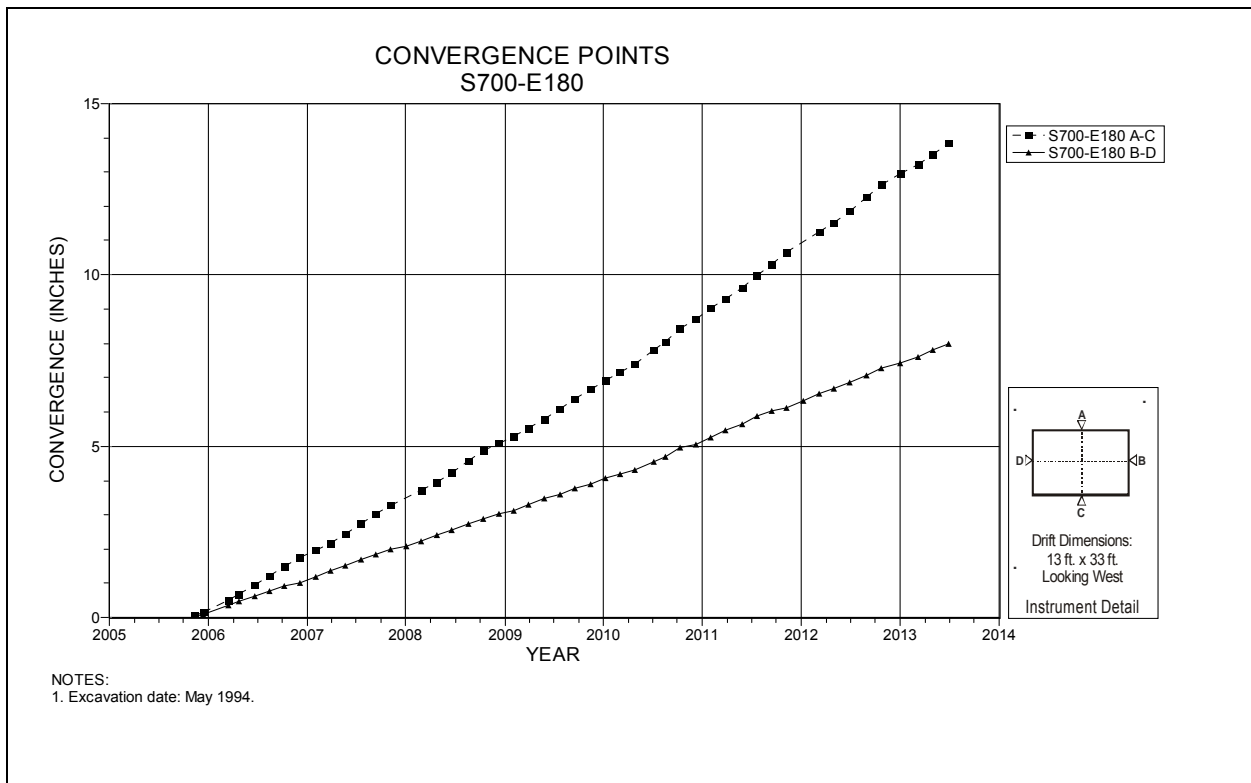

Figure 4-166 Convergence Point Array
S700 E180 – All Chords

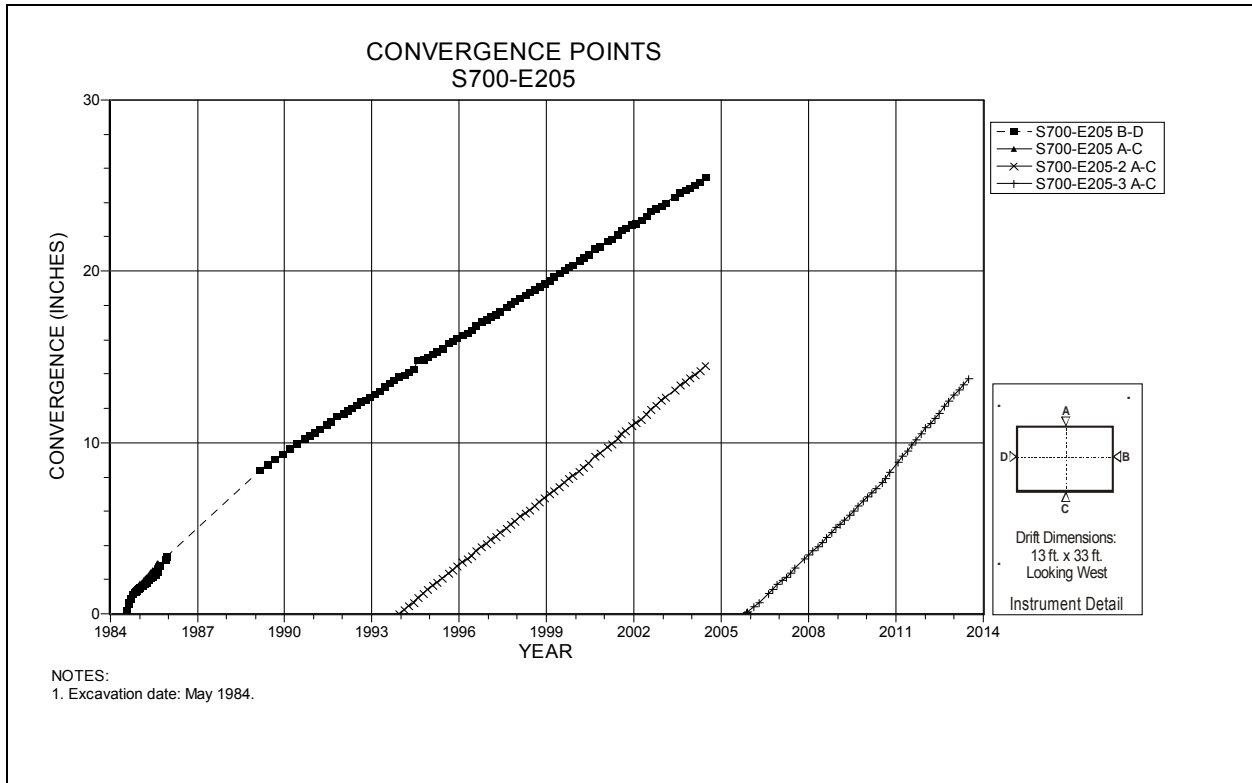

Figure 4-167 Convergence Point Array
S700 E205 – All Chords

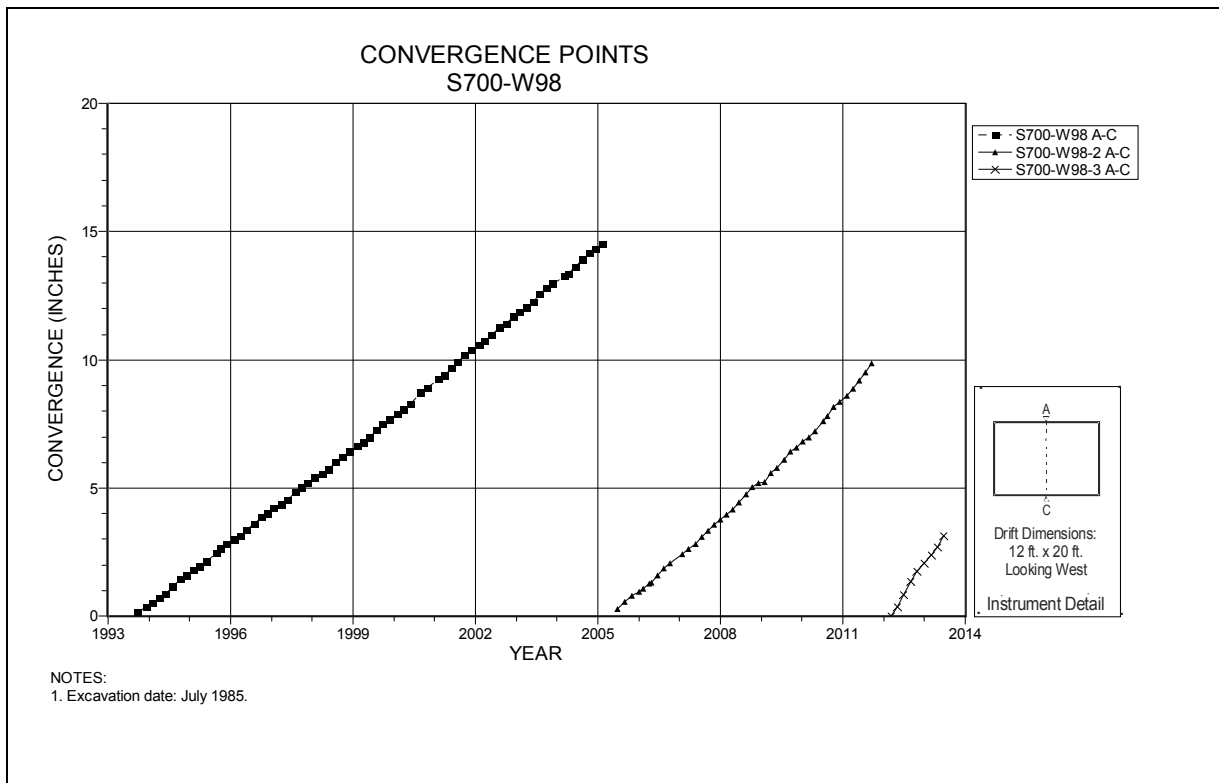

Figure 4-168 Convergence Point Array
S700 W98 – Roof to Floor

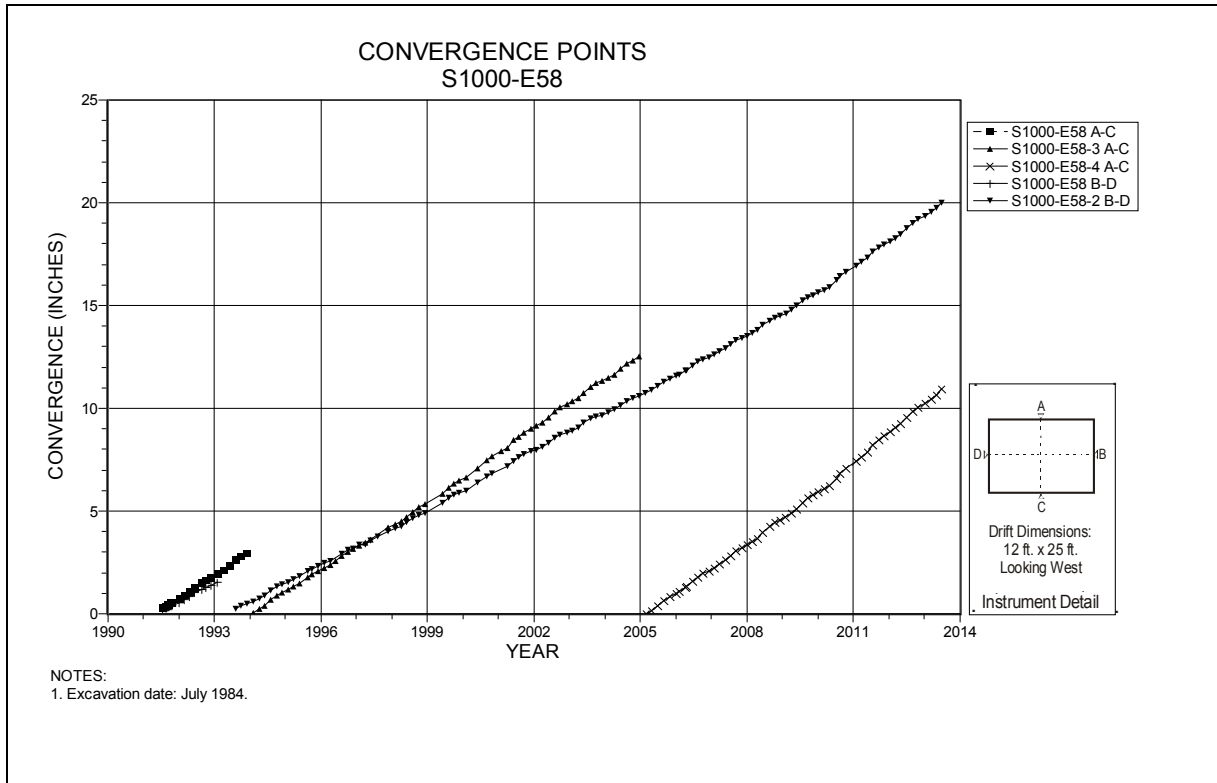

Figure 4-169 Convergence Point Array
S1000 E58 – All Chords

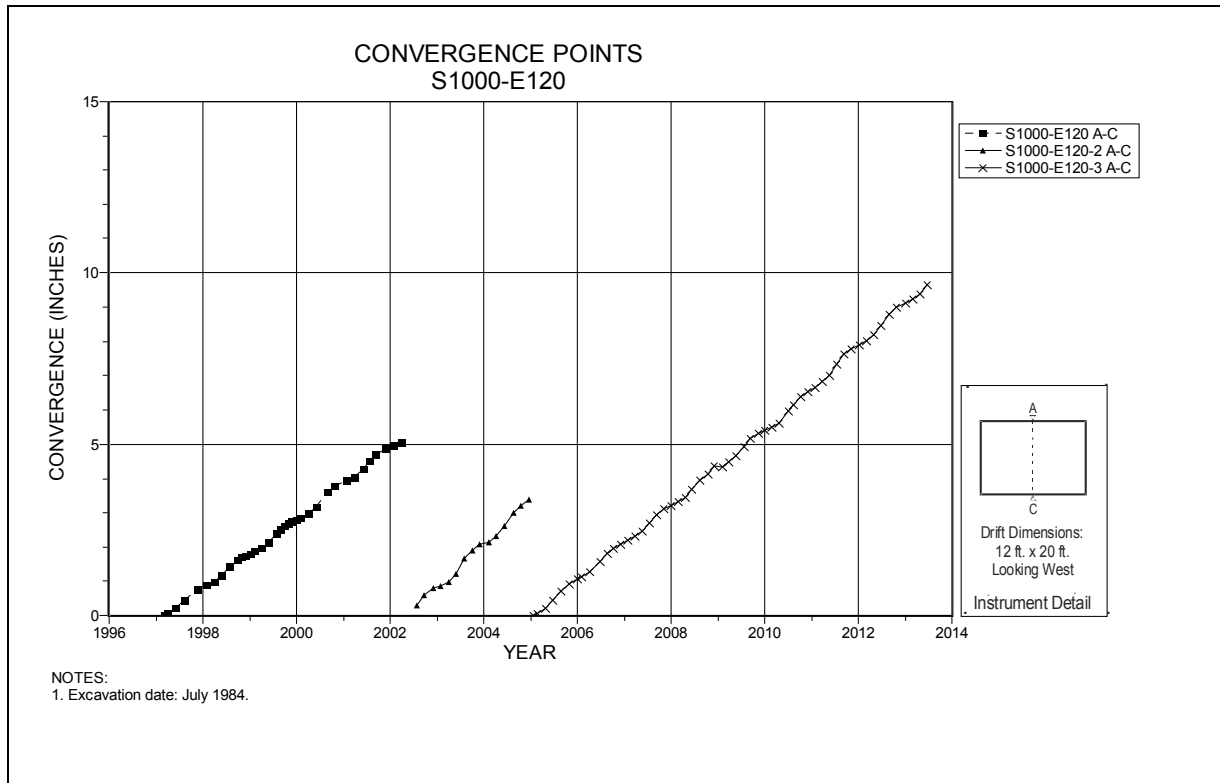
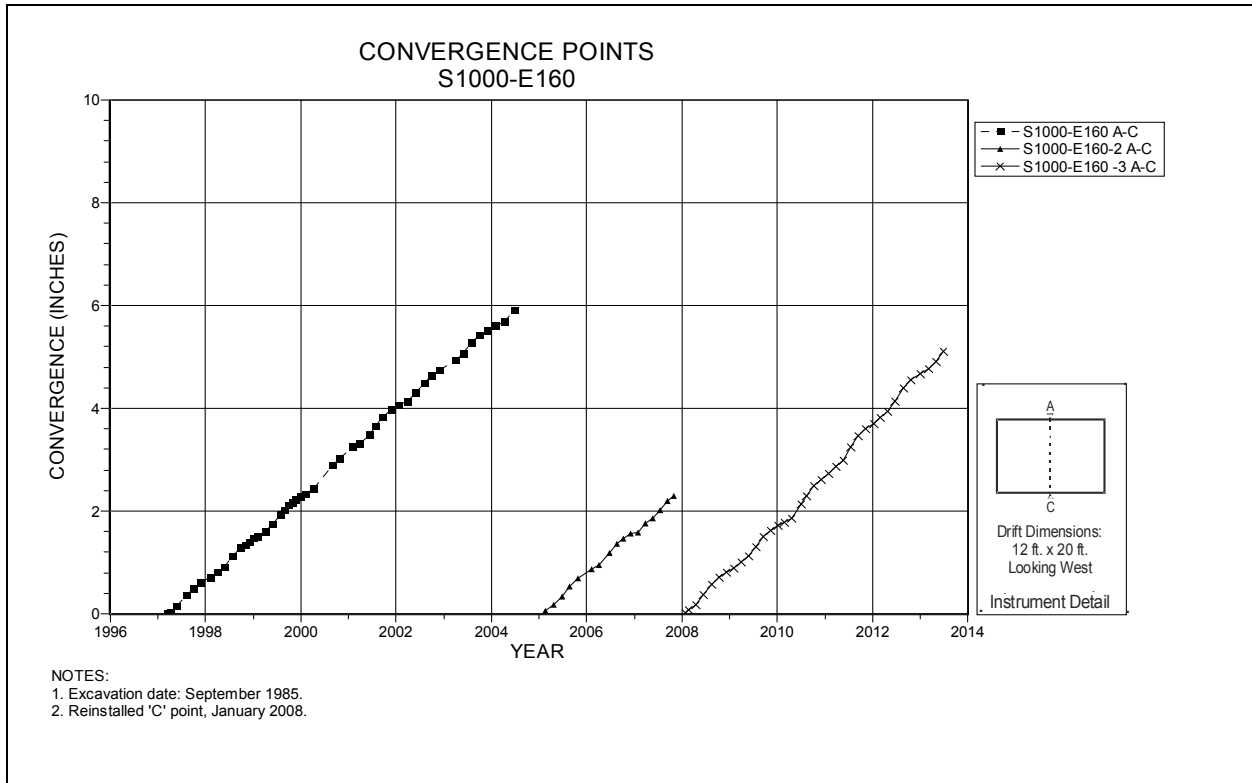
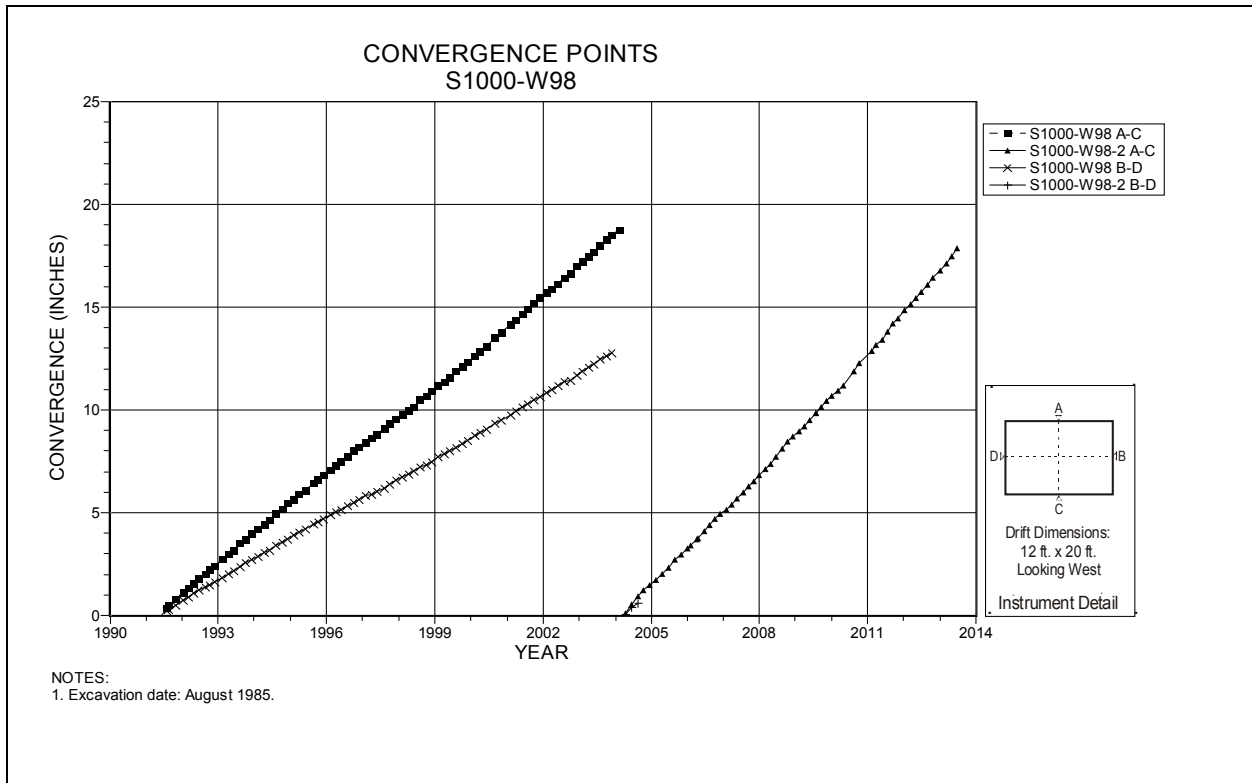

Figure 4-170 Convergence Point Array
S1000 E120 – Roof to Floor



**Figure 4-171 Convergence Point Array
S1000 E160 – Roof to Floor**



**Figure 4-172 Convergence Point Array
S1000 W98 – All Chords**

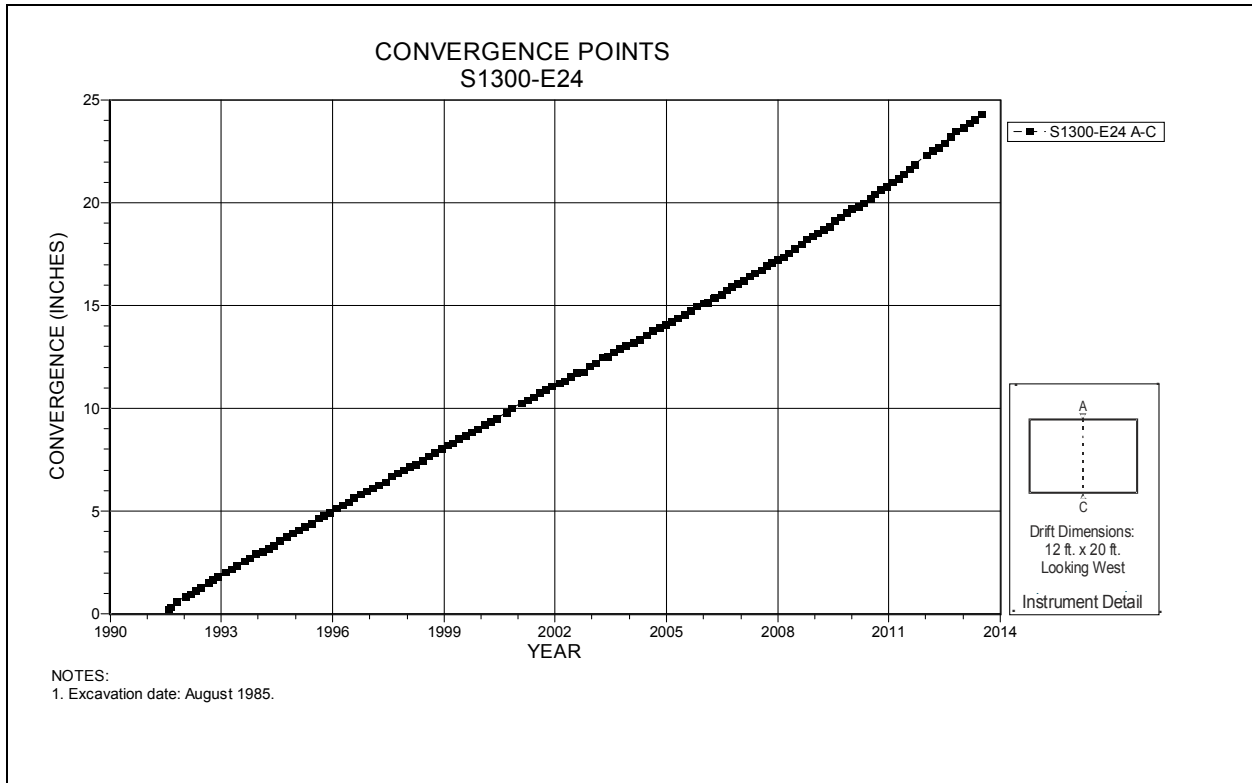

Figure 4-173 Convergence Point Array
S1300 E24 – Roof to Floor

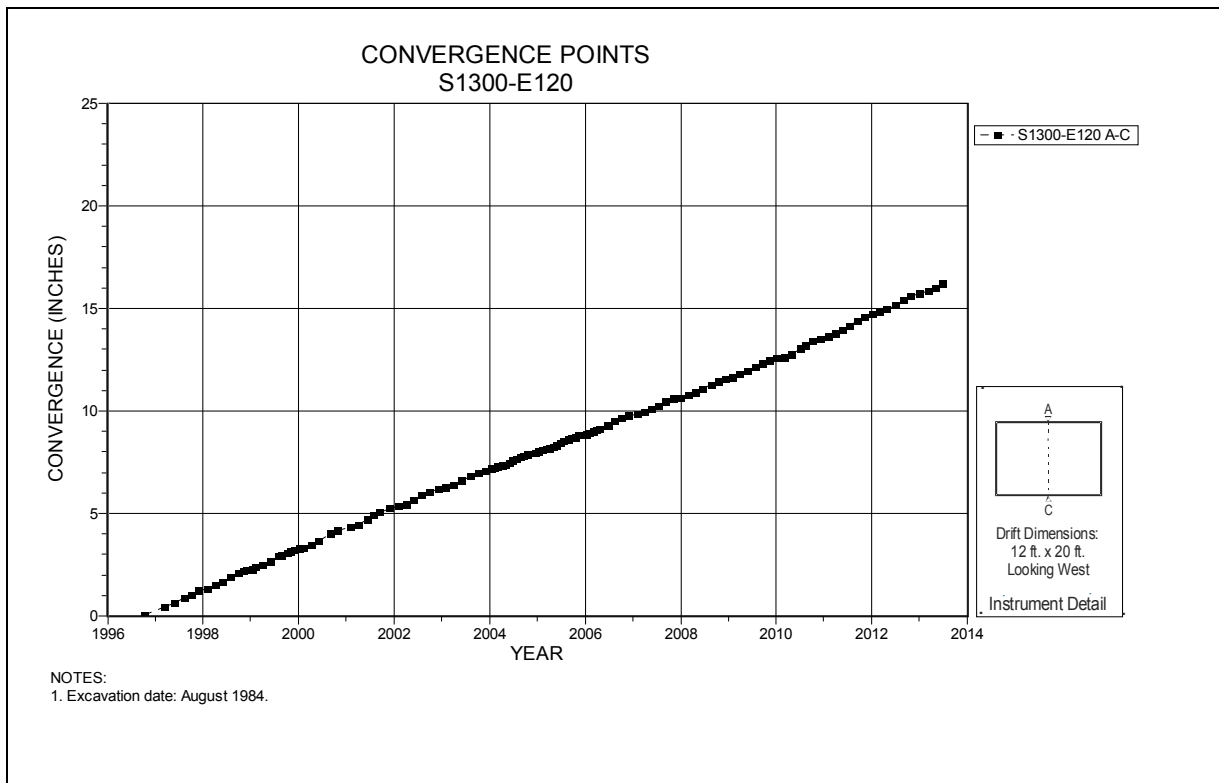
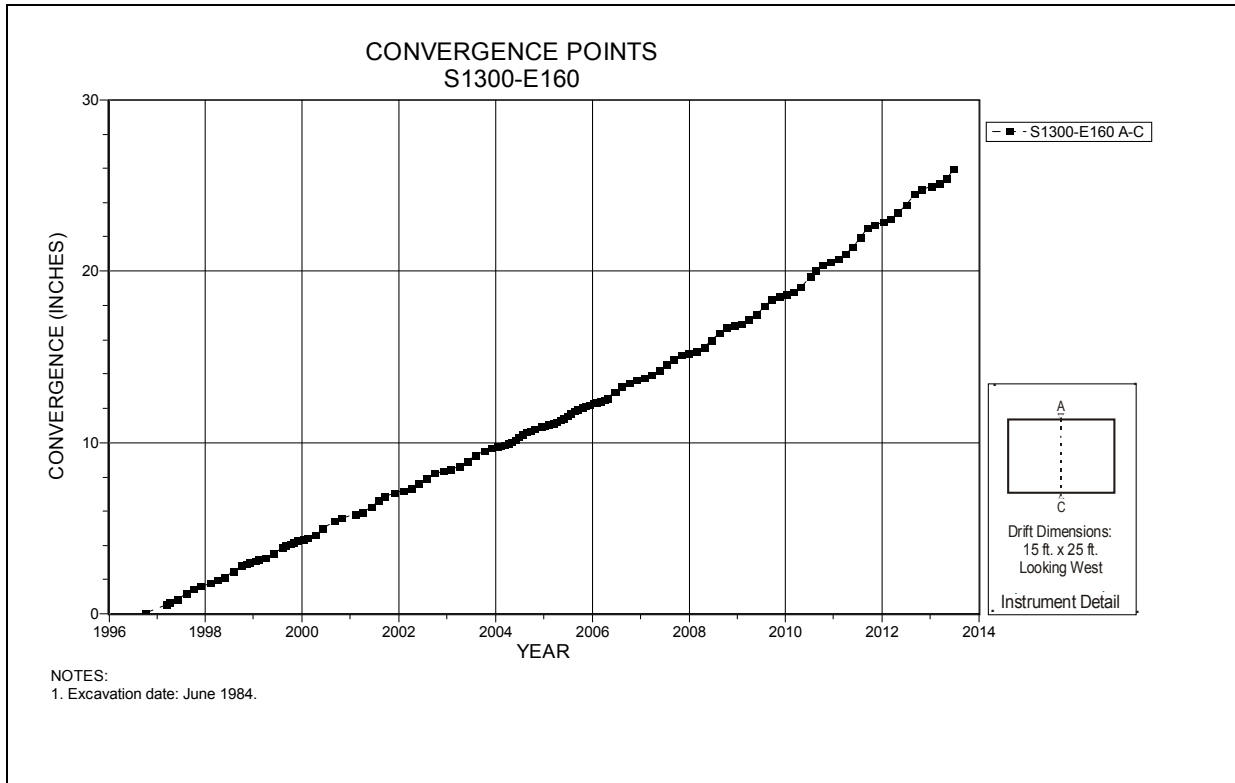
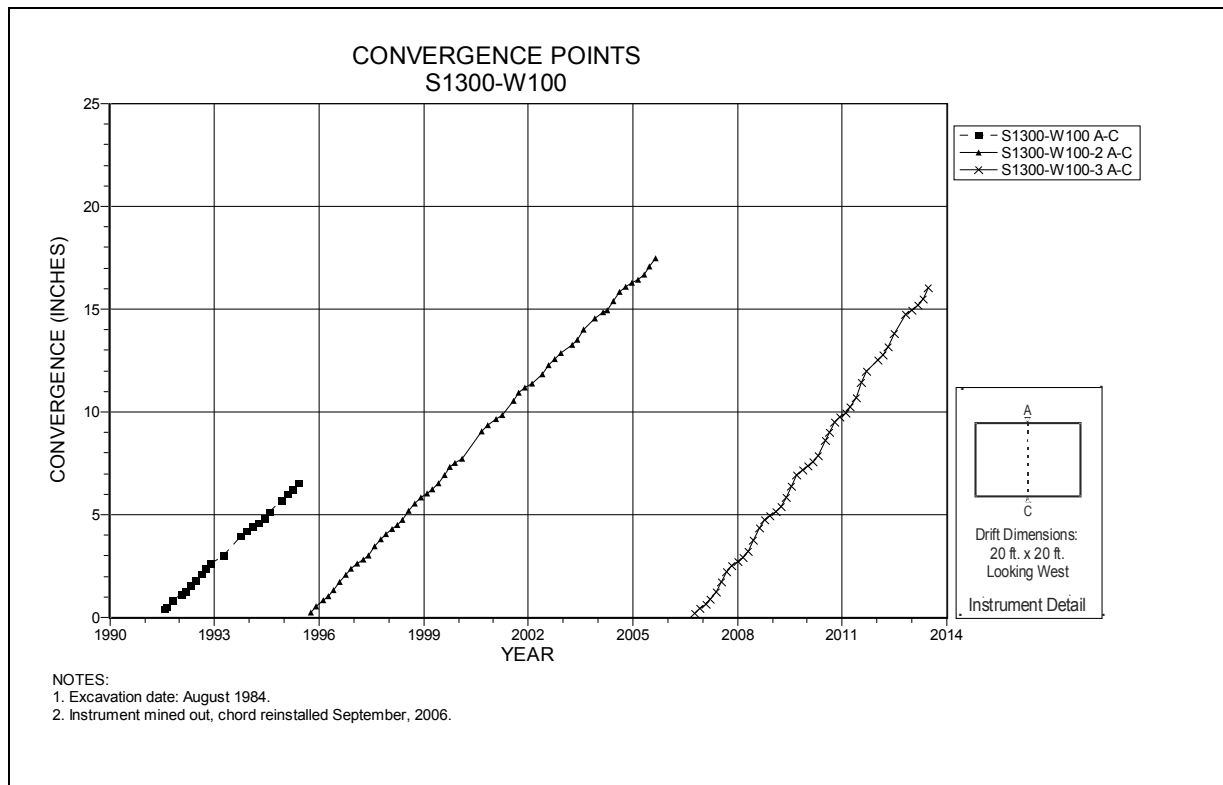

Figure 4-174 Convergence Point Array
S1300 E120 – Roof to Floor



**Figure 4-175 Convergence Point Array
S1300 E160 – Roof to Floor**



**Figure 4-176 Convergence Point Array
S1300 W100 – Roof to Floor**

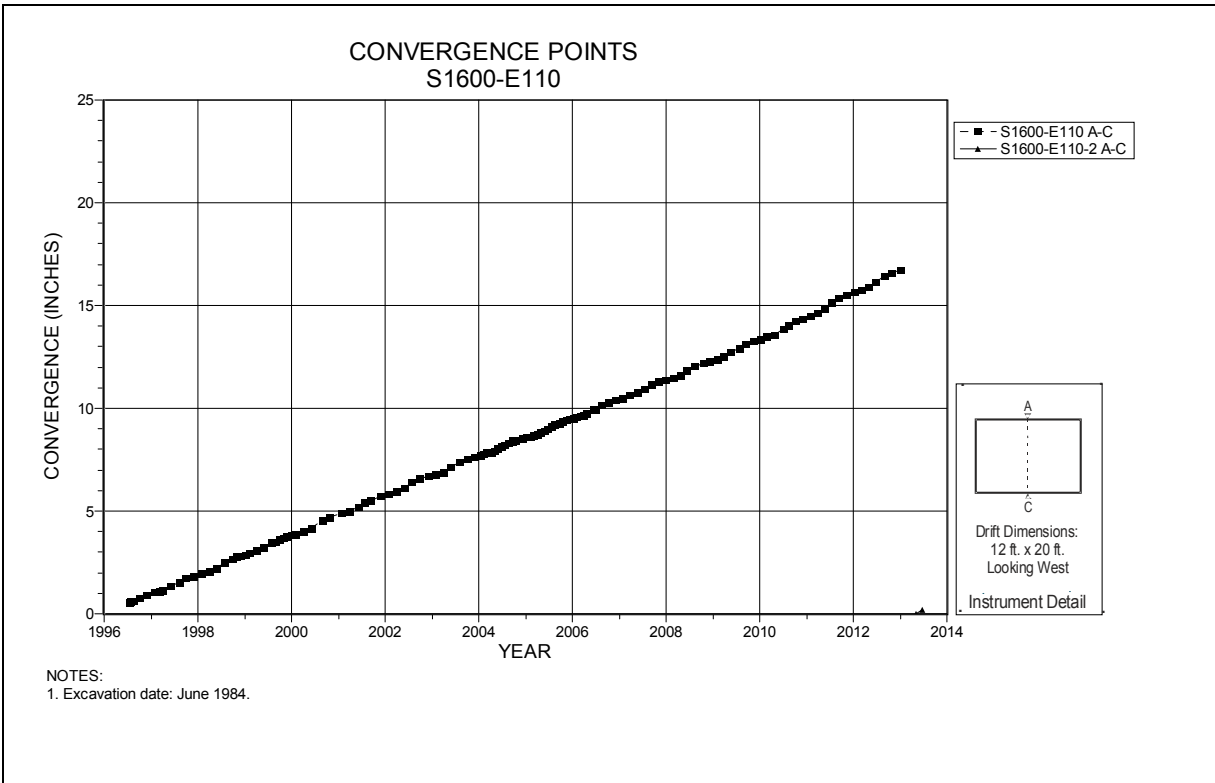

Figure 4-177 Convergence Point Array
S1600 E110 – Roof to Floor

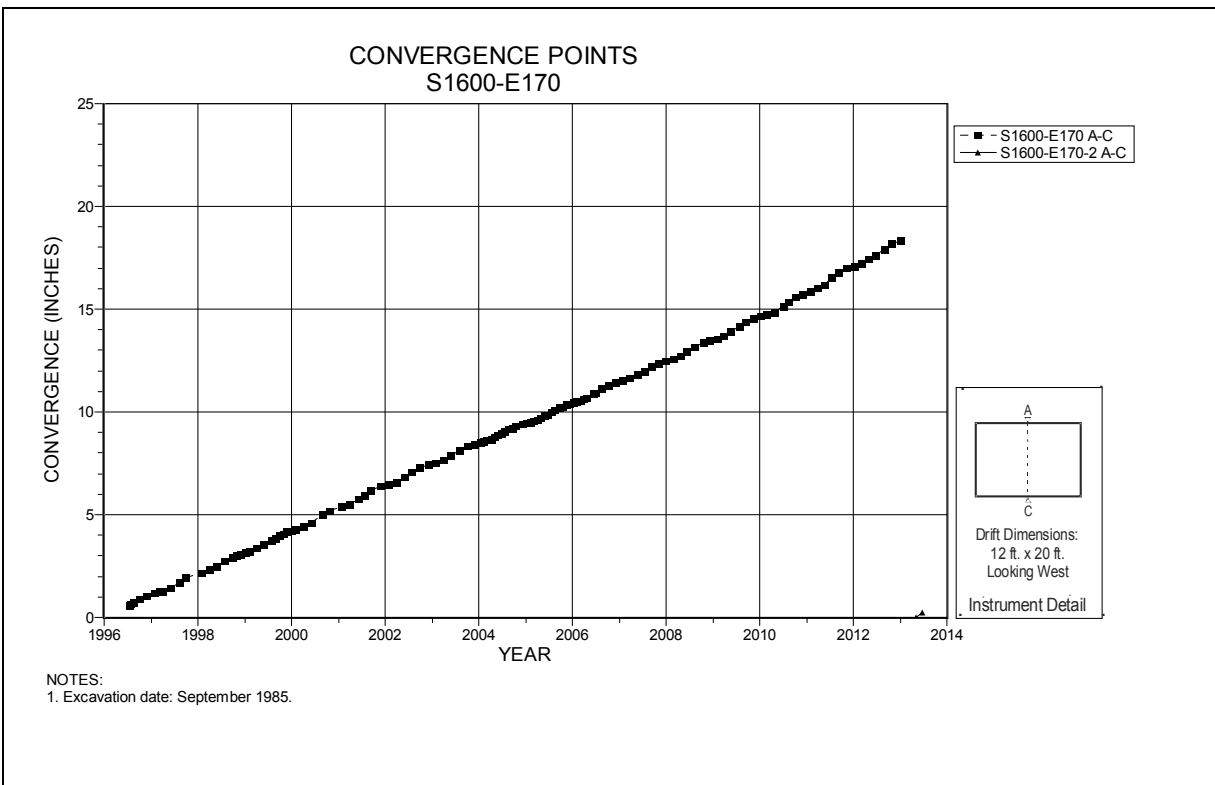

Figure 4-178 Convergence Point Array
S1600 E170 – Roof to Floor

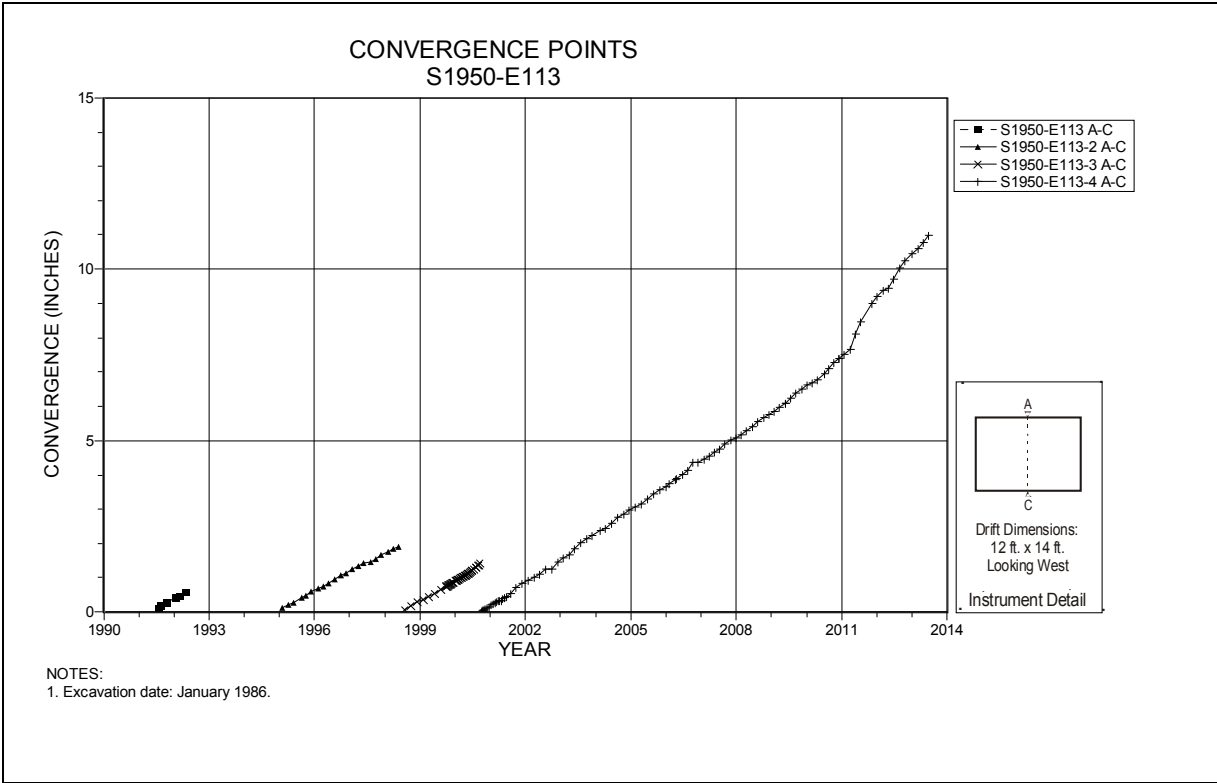

Figure 4-179 Convergence Point Array
S1950 E113 – Roof to Floor

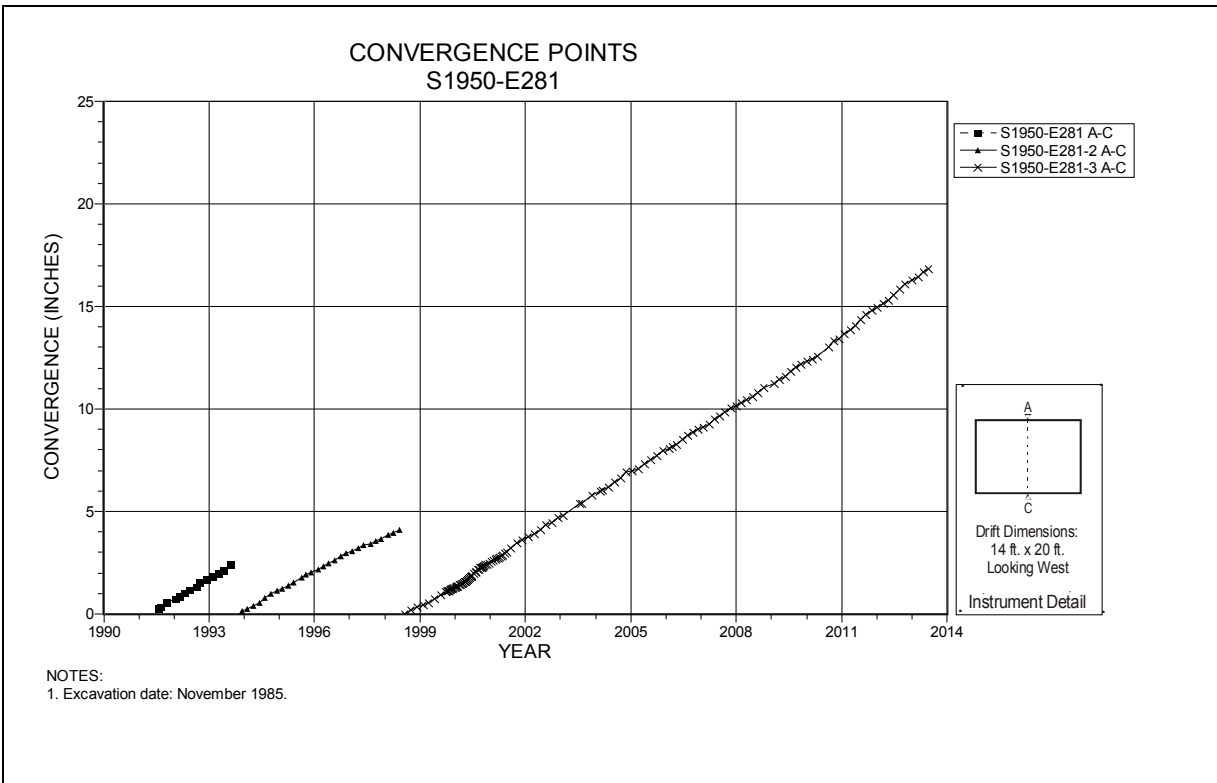

Figure 4-180 Convergence Point Array
S1950 E281 – Roof to Floor

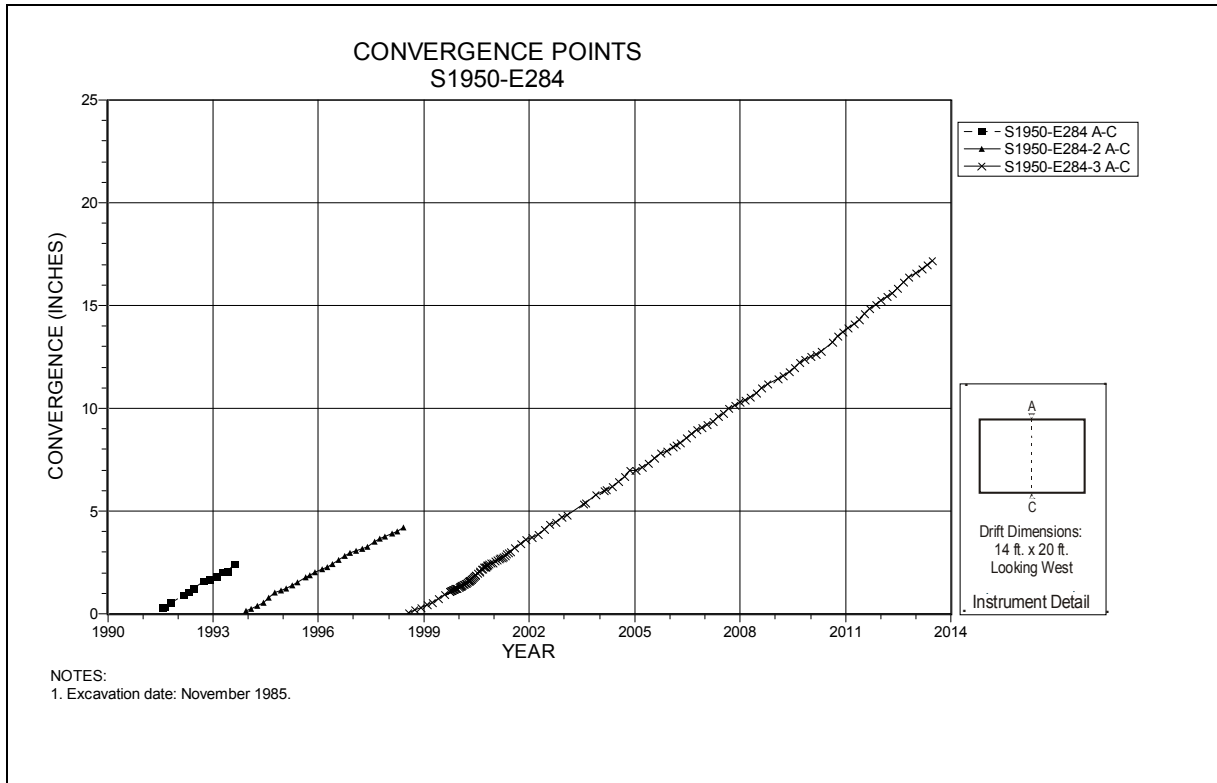

Figure 4-181 Convergence Point Array
S1950 E284 – Roof to Floor

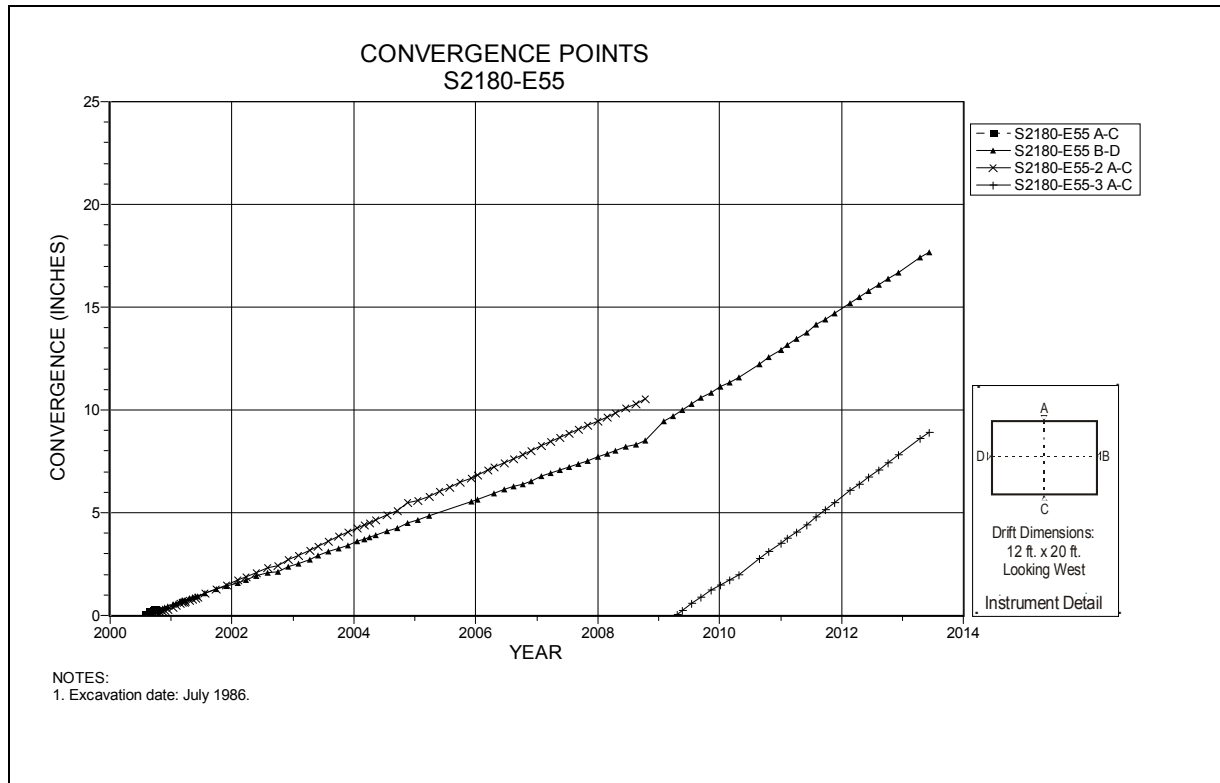

Figure 4-182 Convergence Point Array
S2180 E55 – All Chords

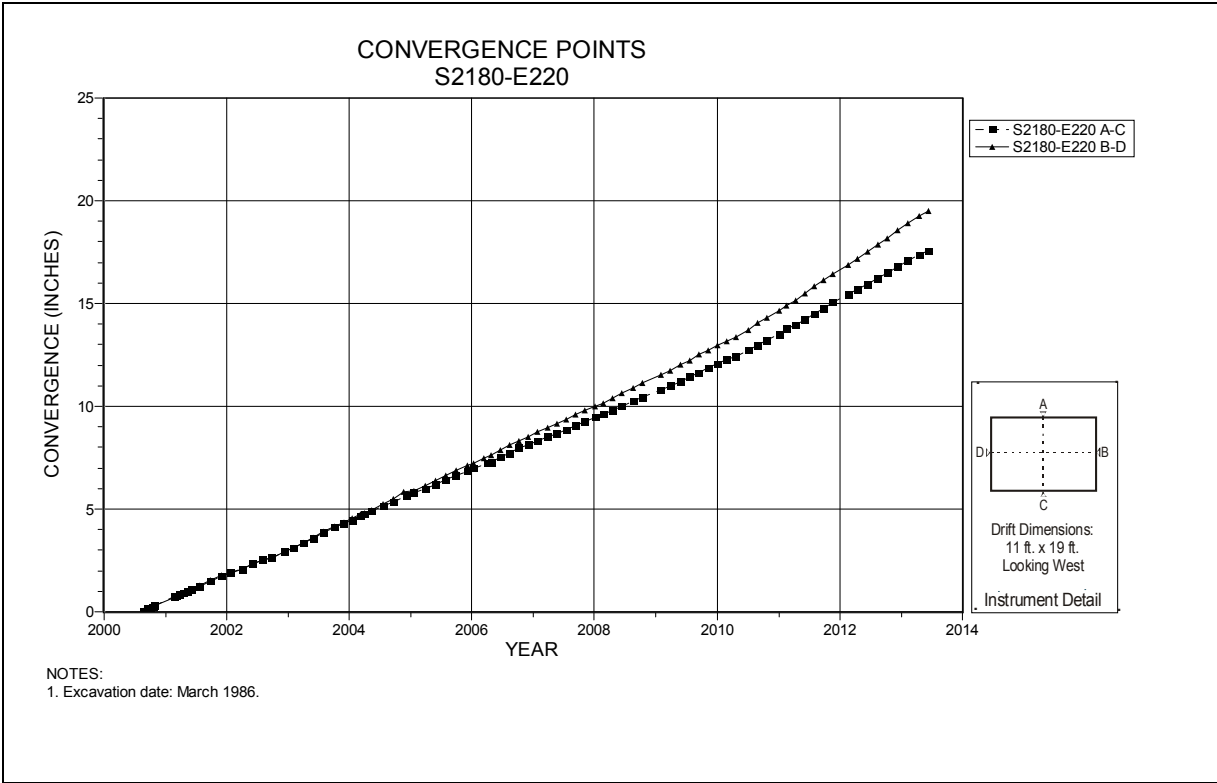

Figure 4-183 Convergence Point Array
S2180 E220 – All Chords

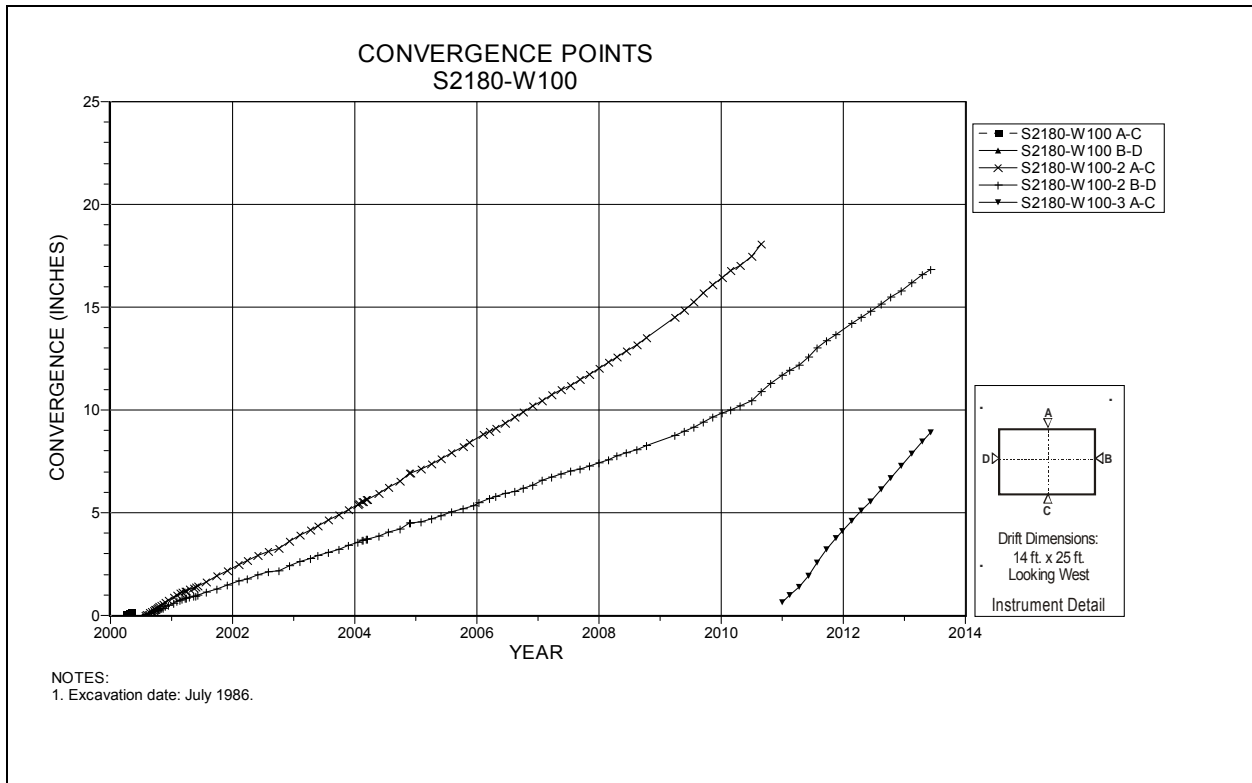

Figure 4-184 Convergence Point Array
S2180 W100 – All Chords

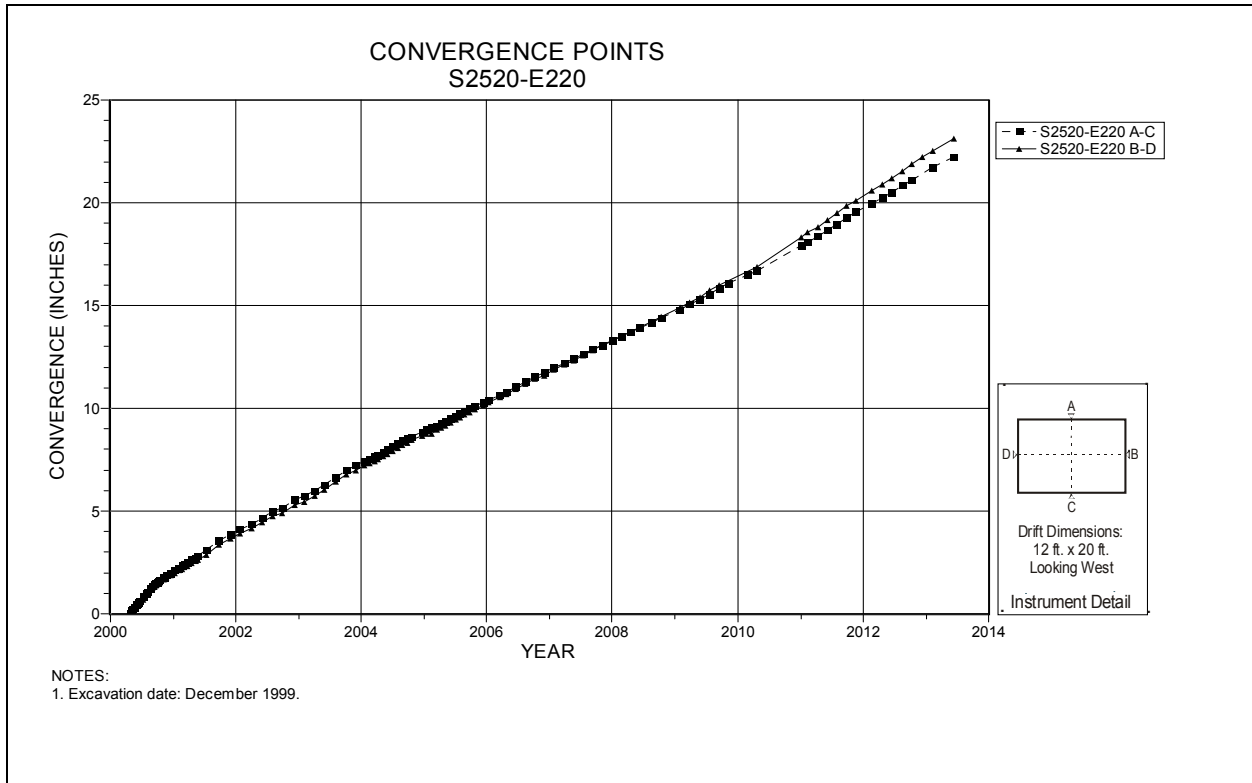

Figure 4-185 Convergence Point Array
S2520 E220 – All Chords

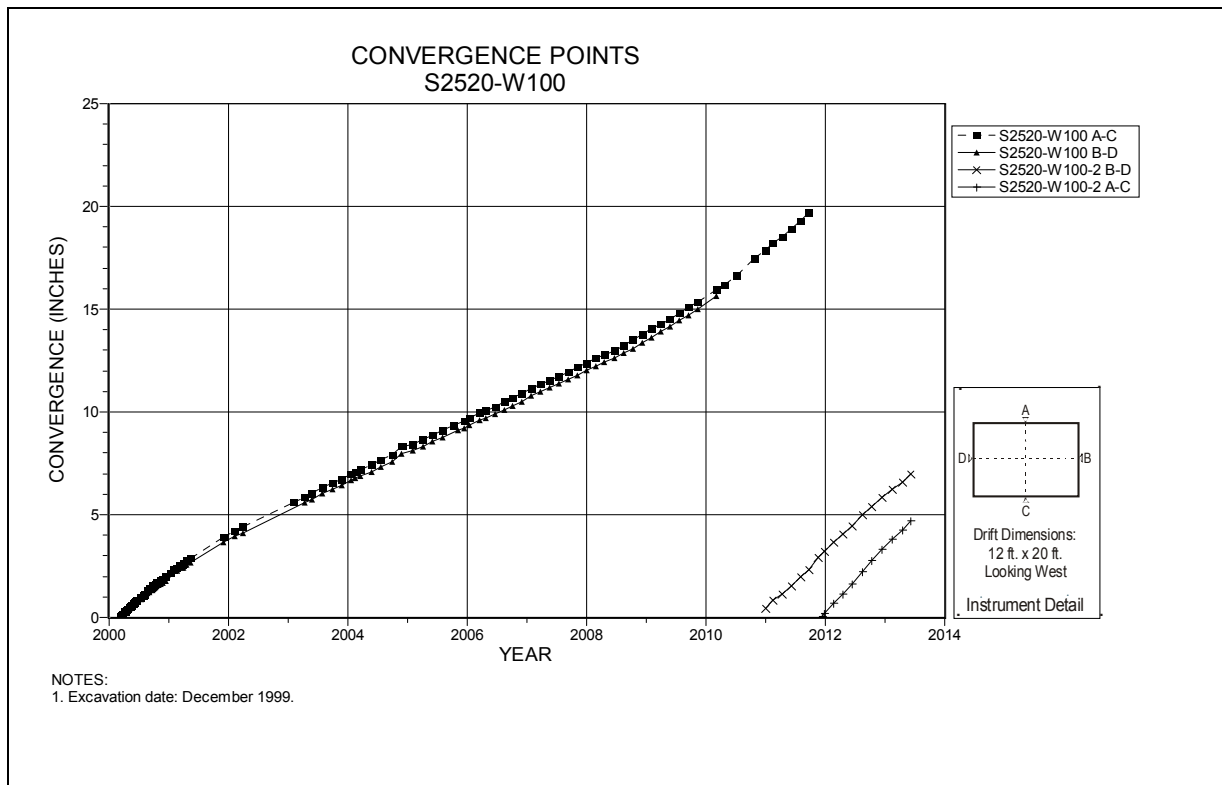

Figure 4-186 Convergence Point Array
S2520 W100 – All Chords

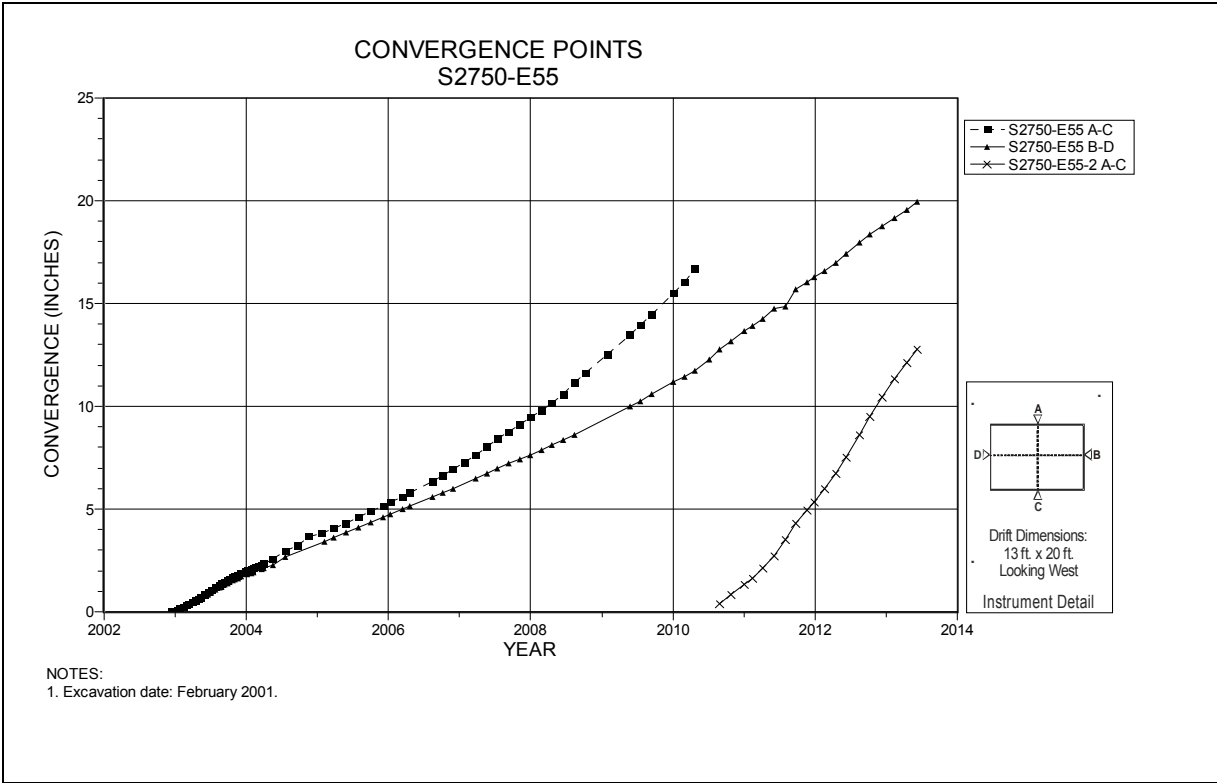

Figure 4-187 Convergence Point Array
S2750 E55 – All Chords

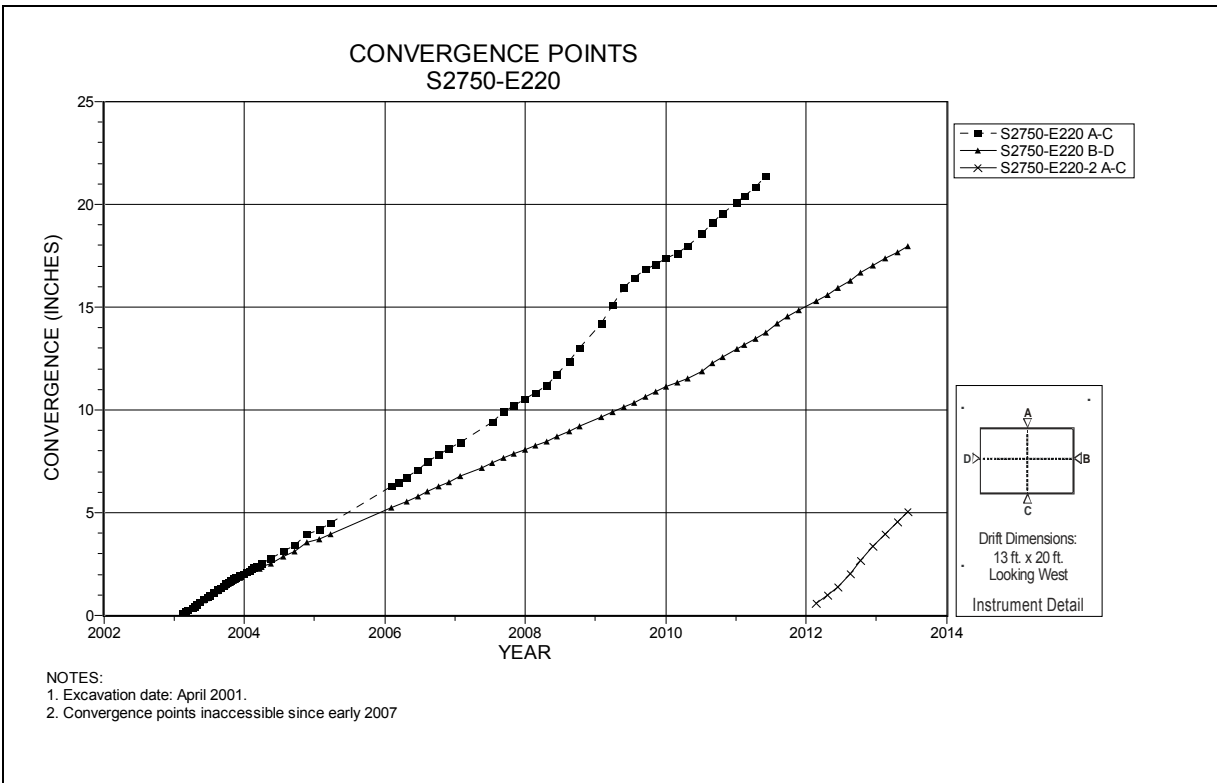

Figure 4-188 Convergence Point Array
S2750 E220 – All Chords

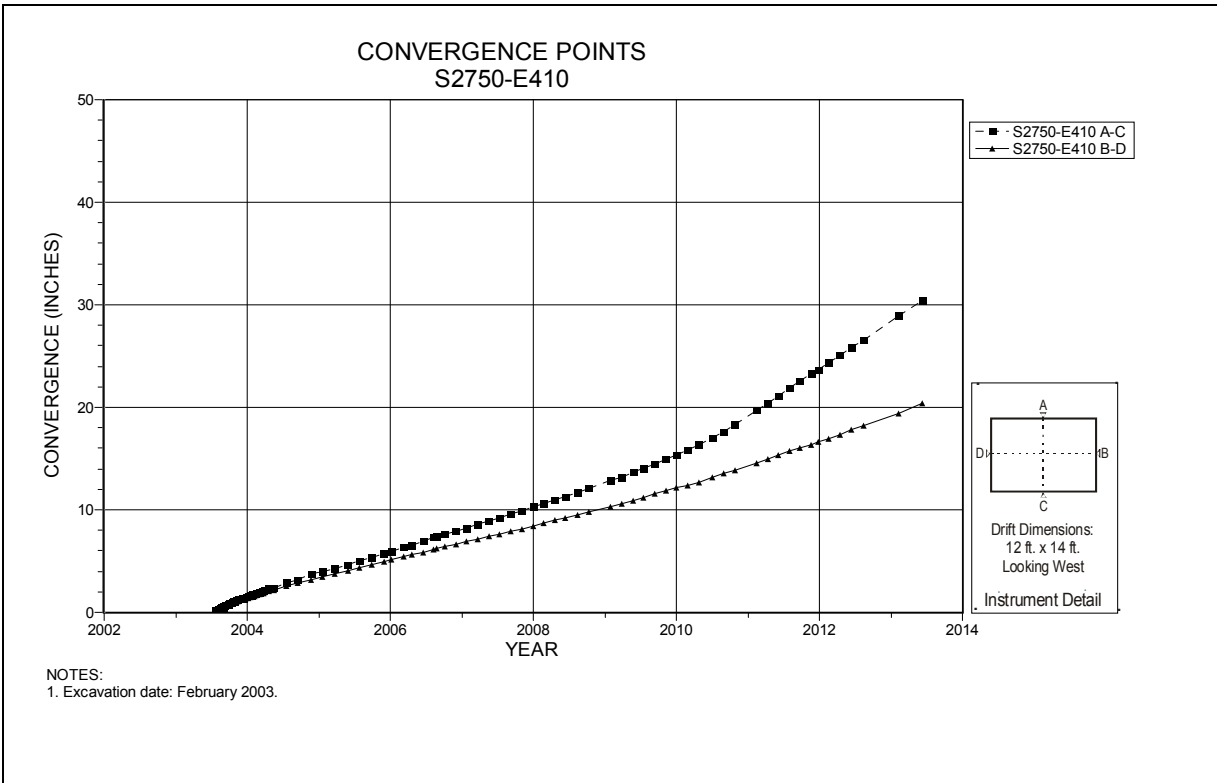

Figure 4-189 Convergence Point Array
S2750 E410 – All Chords

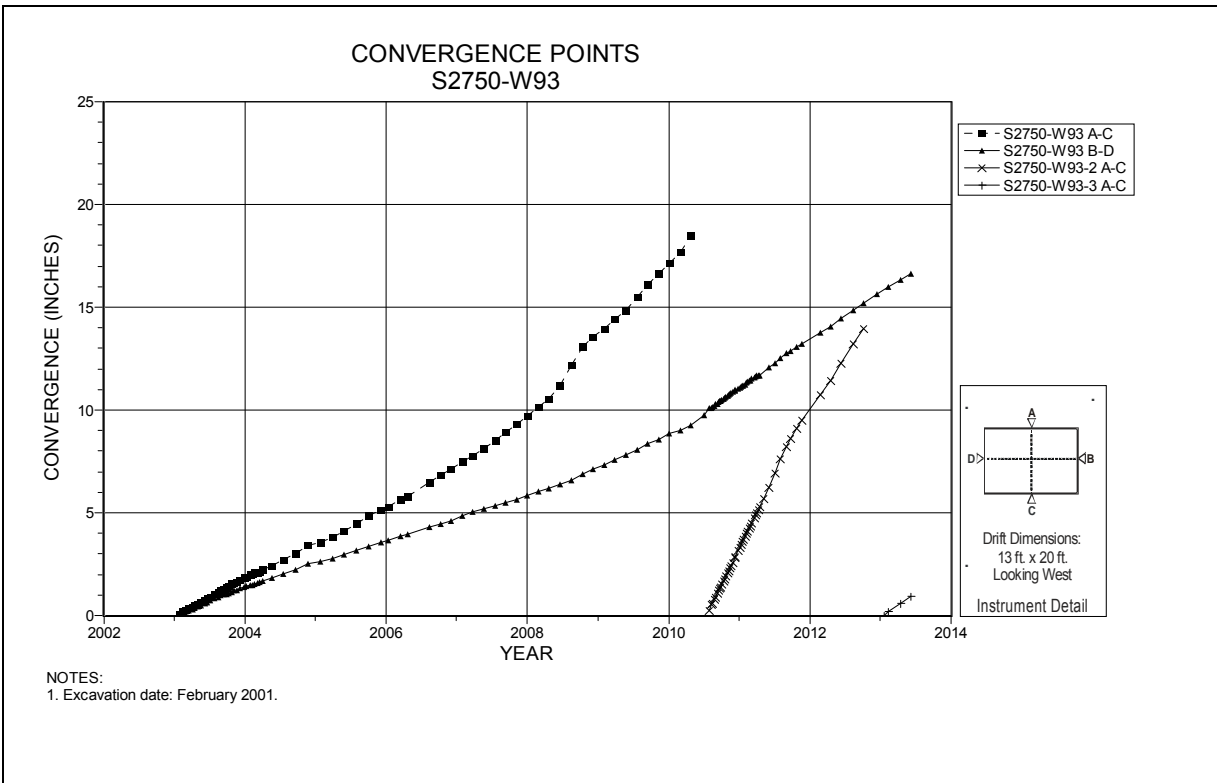

Figure 4-190 Convergence Point Array
S2750 W93 – All Chords

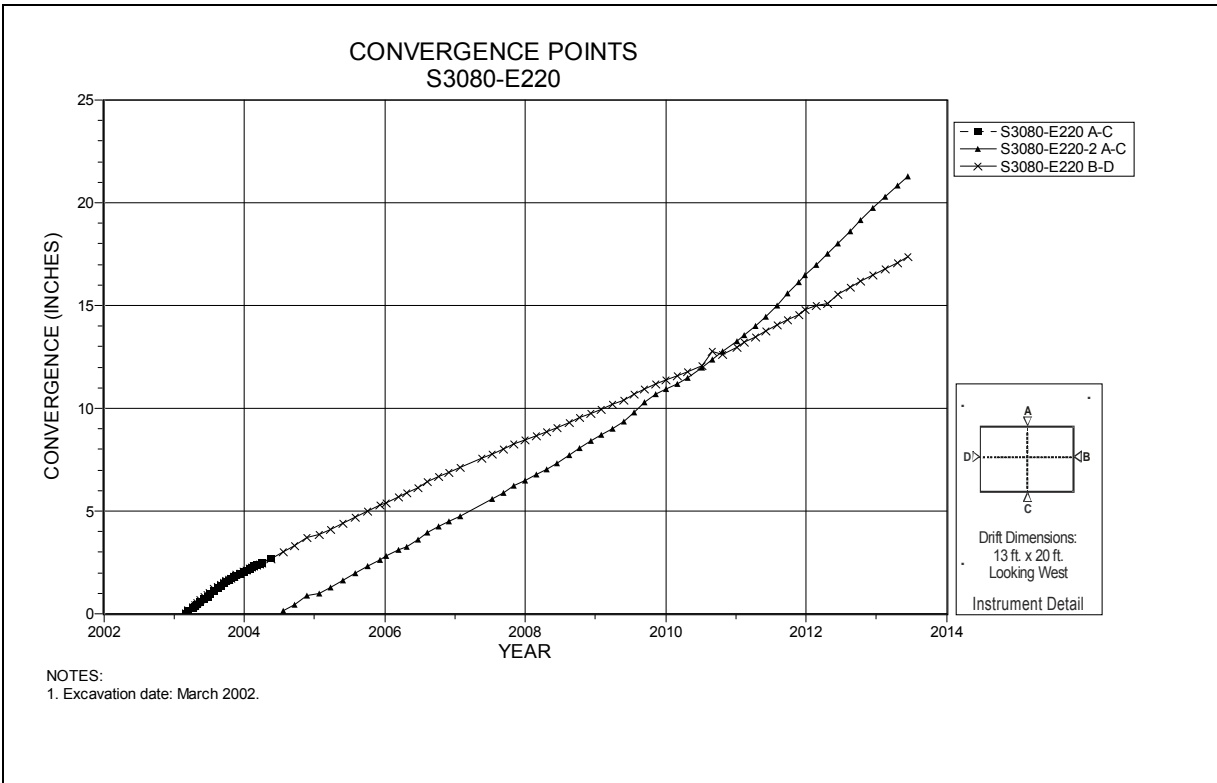

Figure 4-191 Convergence Point Array
S3080 E220 – All Chords

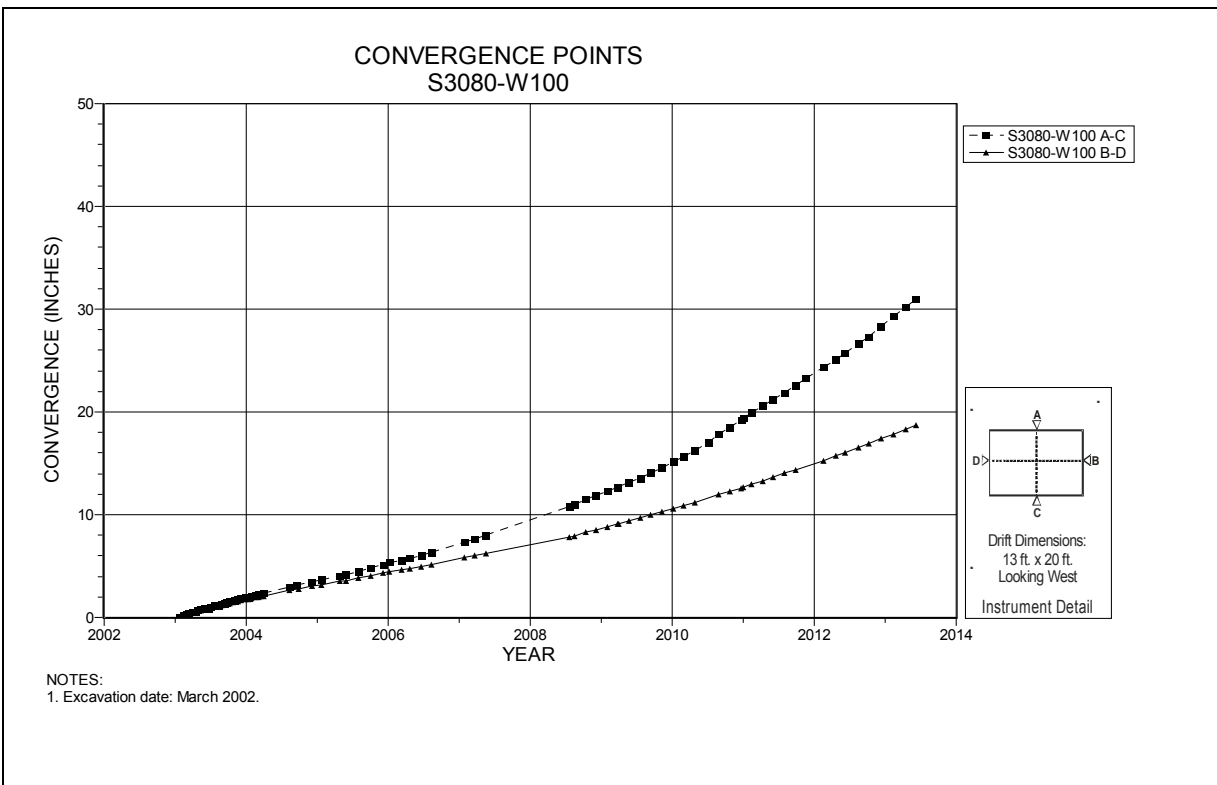

Figure 4-192 Convergence Point Array
S3080 W100 – All Chords

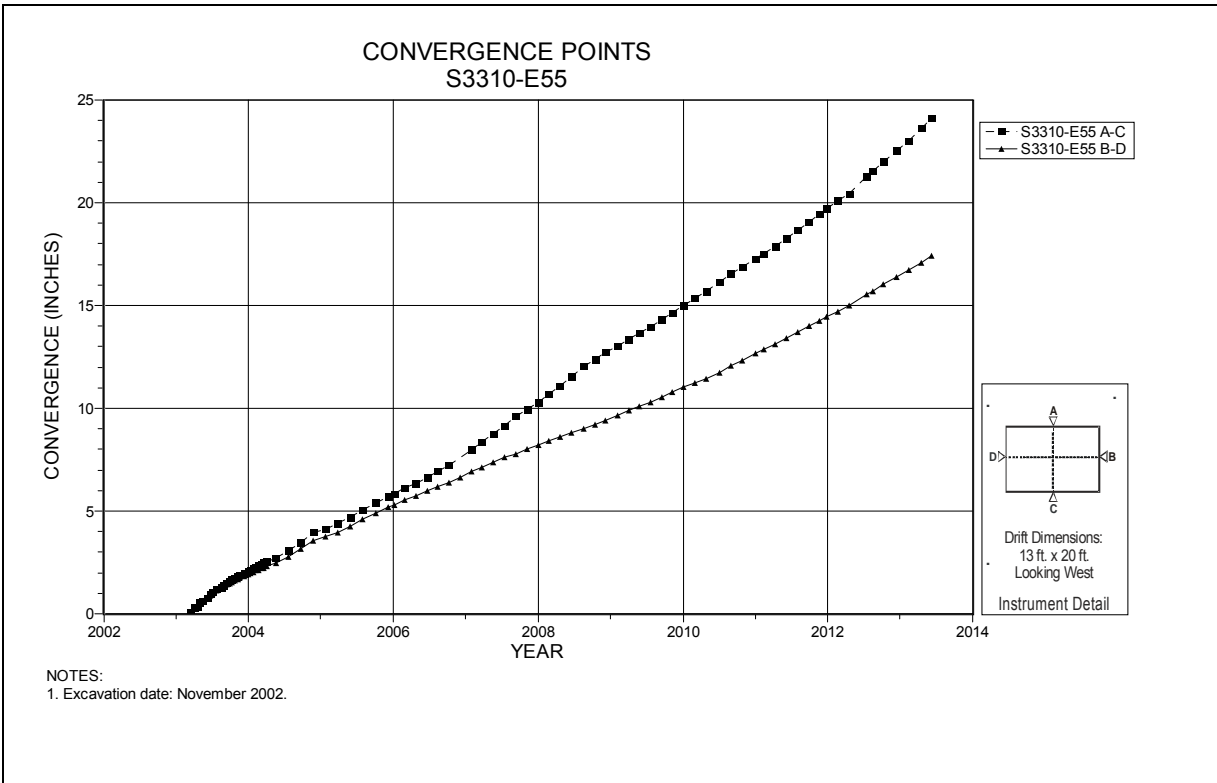

Figure 4-193 Convergence Point Array
S3310 E55 – All Chords

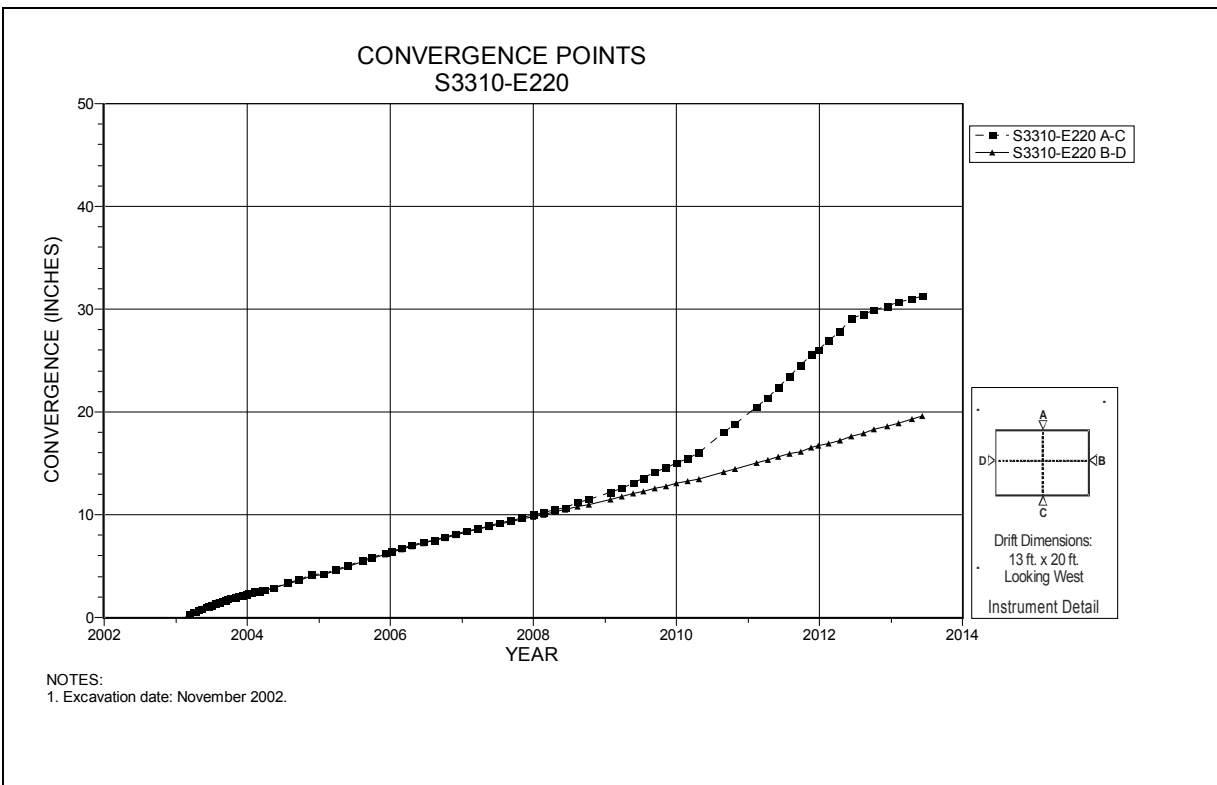
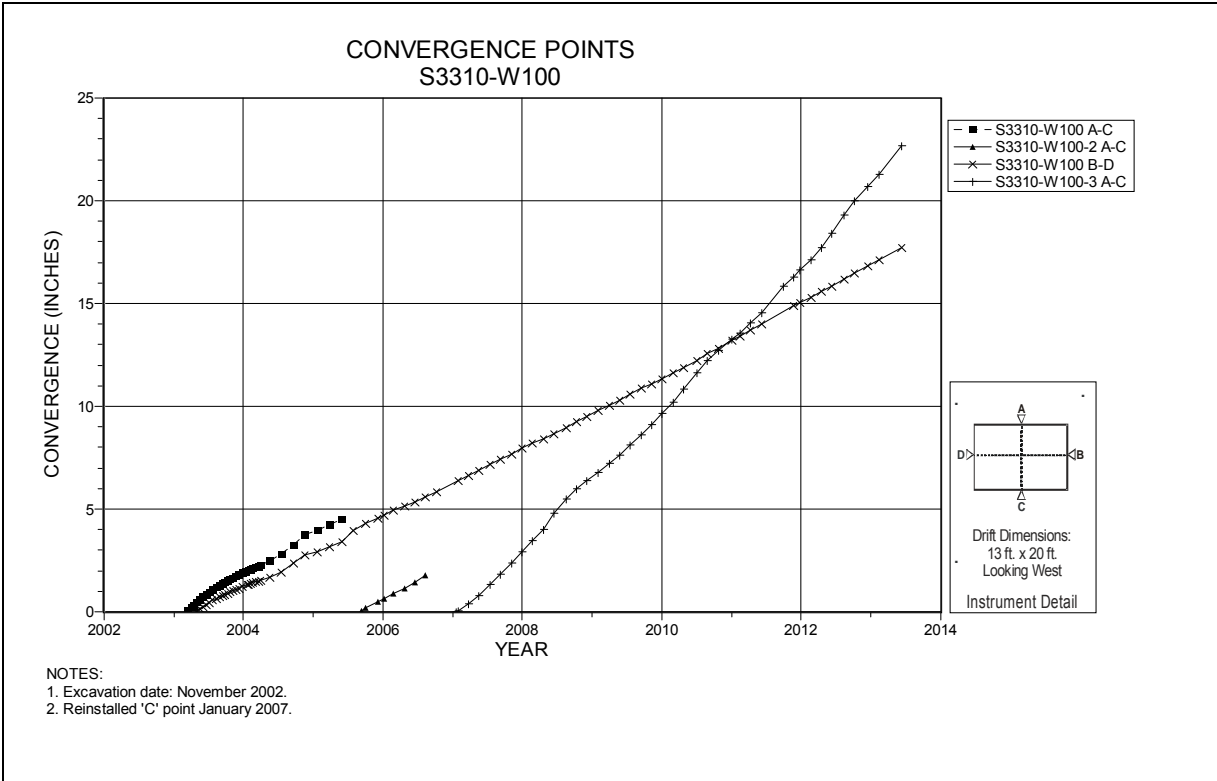
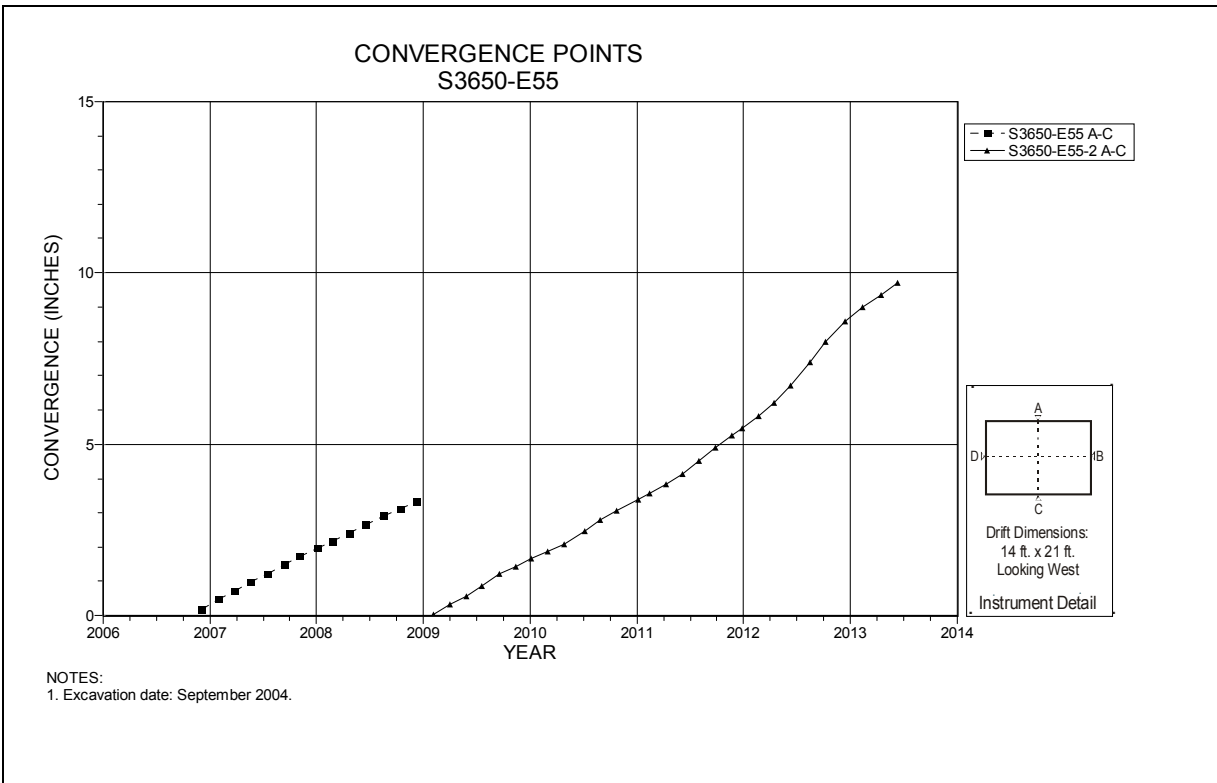

Figure 4-194 Convergence Point Array
S3310 E220 – All Chords



**Figure 4-195 Convergence Point Array
S3310 W100 – All Chords**



**Figure 4-196 Convergence Point Array
S3650 E55 – Roof to Floor**

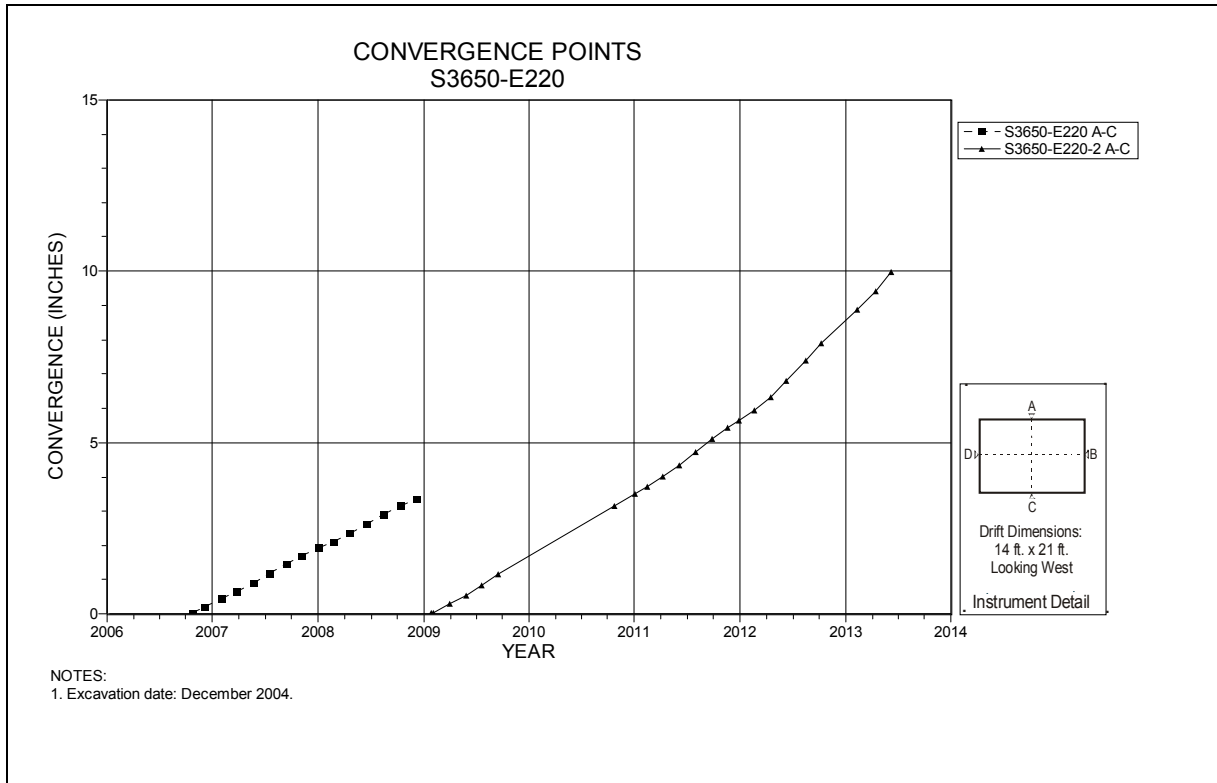

Figure 4-197 Convergence Point Array
S3650 E220 – Roof to Floor

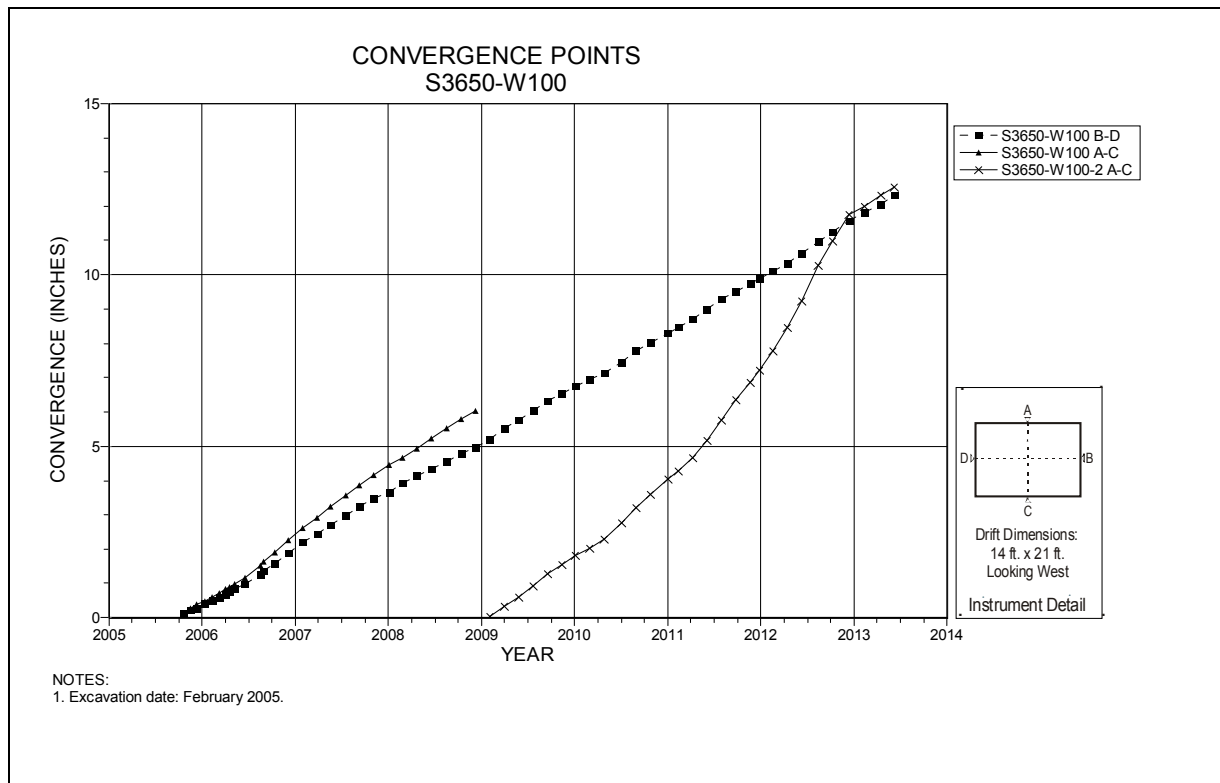

Figure 4-198 Convergence Point Array
S3650 W100 – All Chords

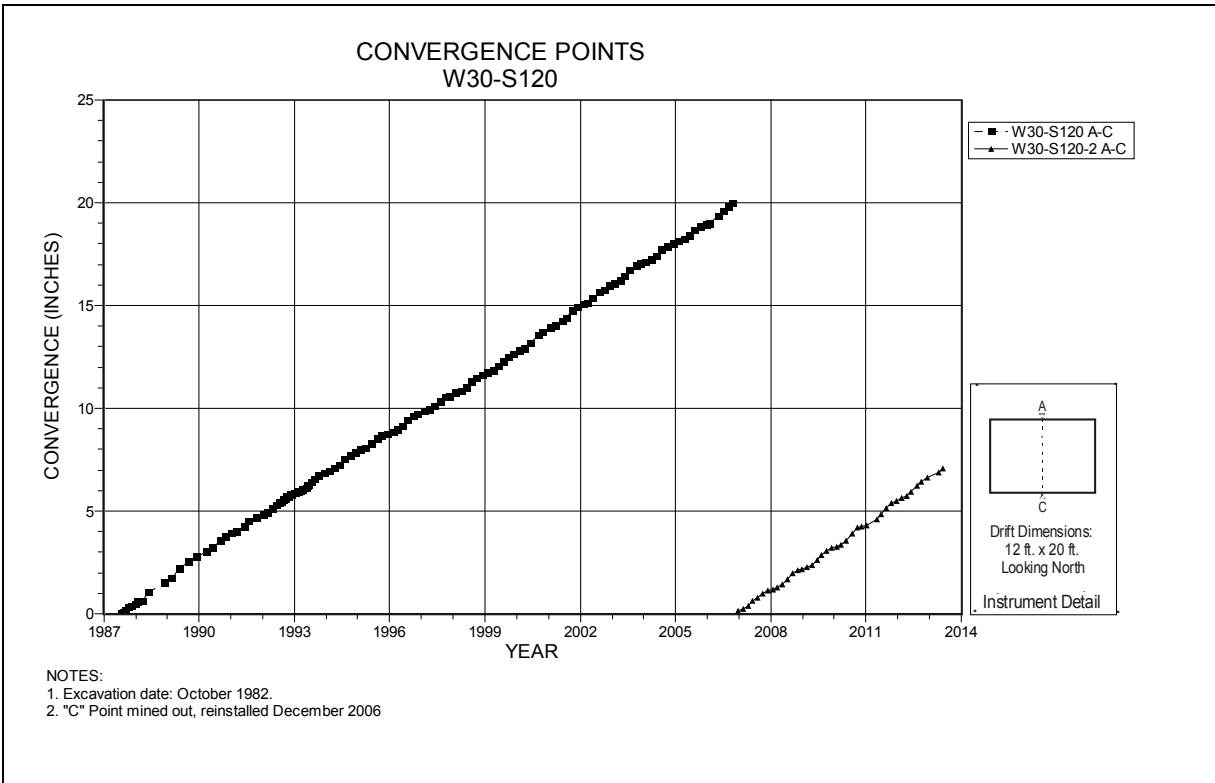

Figure 4-199 Convergence Point Array
W30 S120 – Roof to Floor

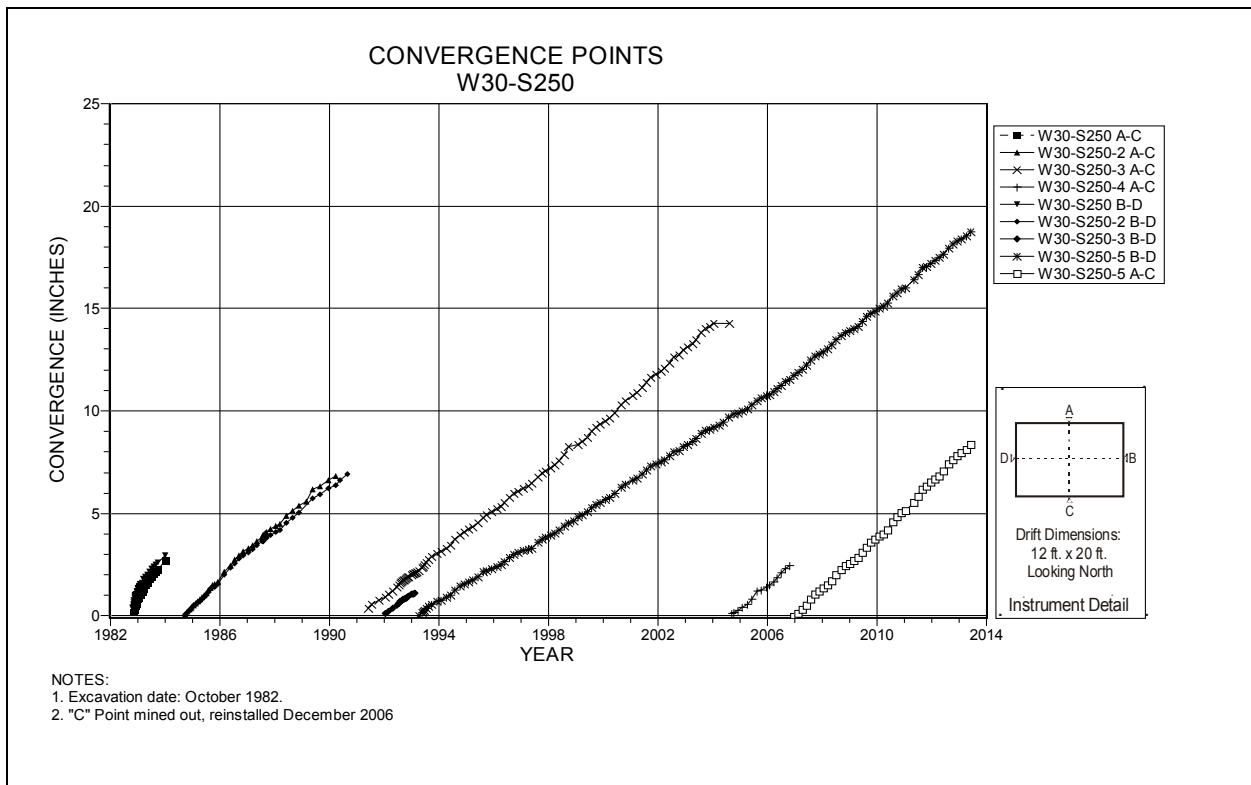

Figure 4-200 Convergence Point Array
W30 S250 – All Chords

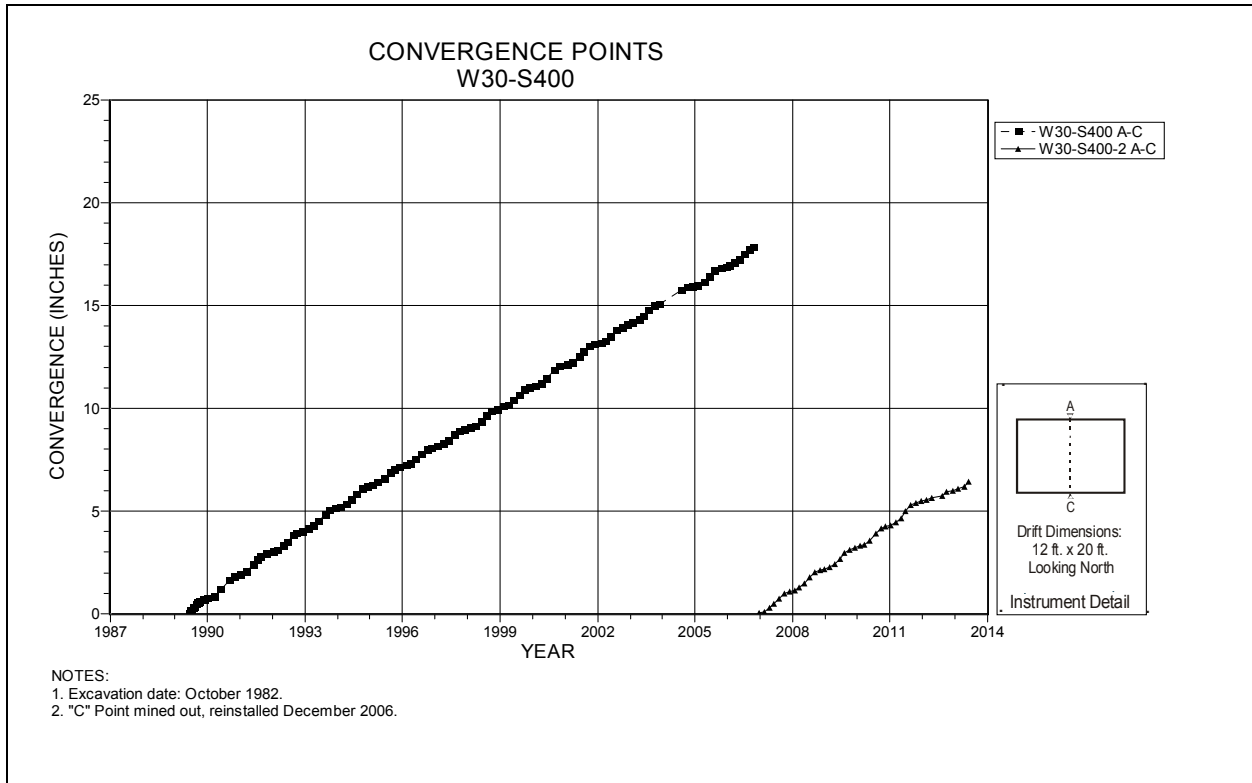

Figure 4-201 Convergence Point Array
W30 S400 – Roof to Floor

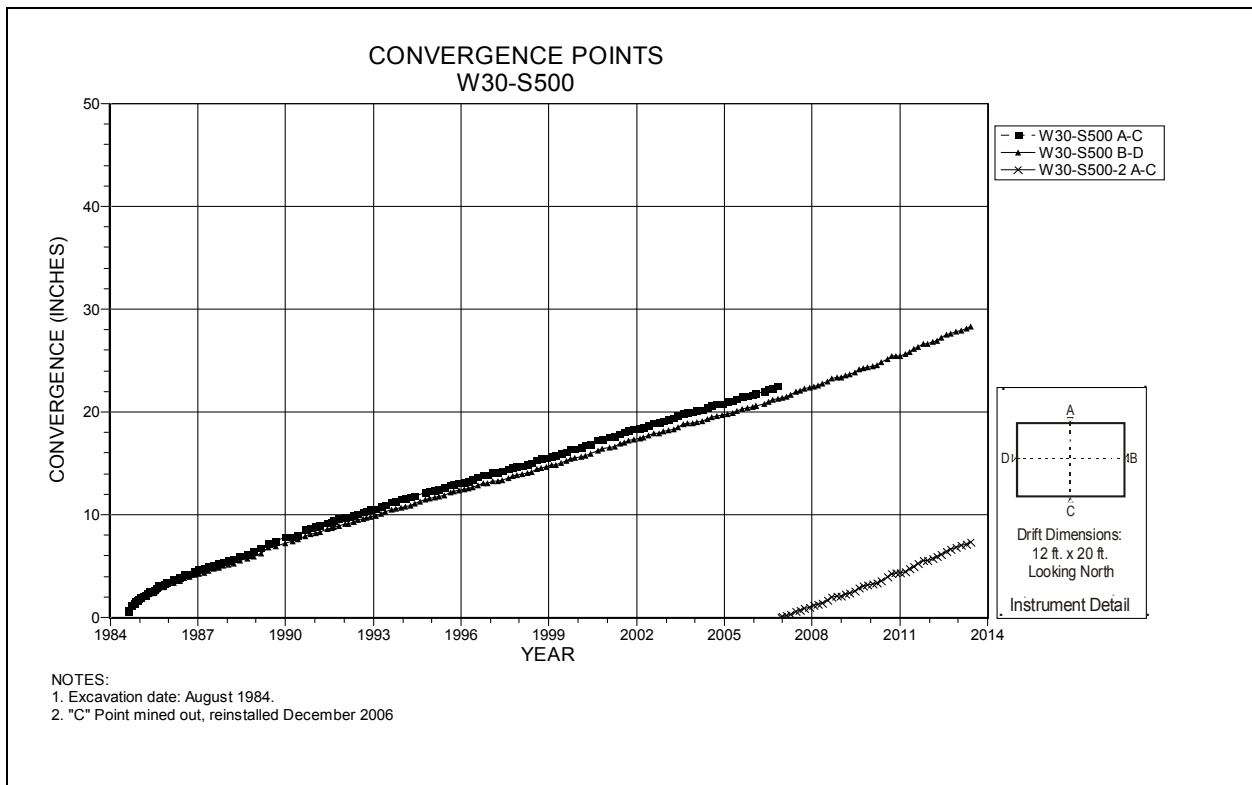

Figure 4-202 Convergence Point Array
W30 S500 – All Chords

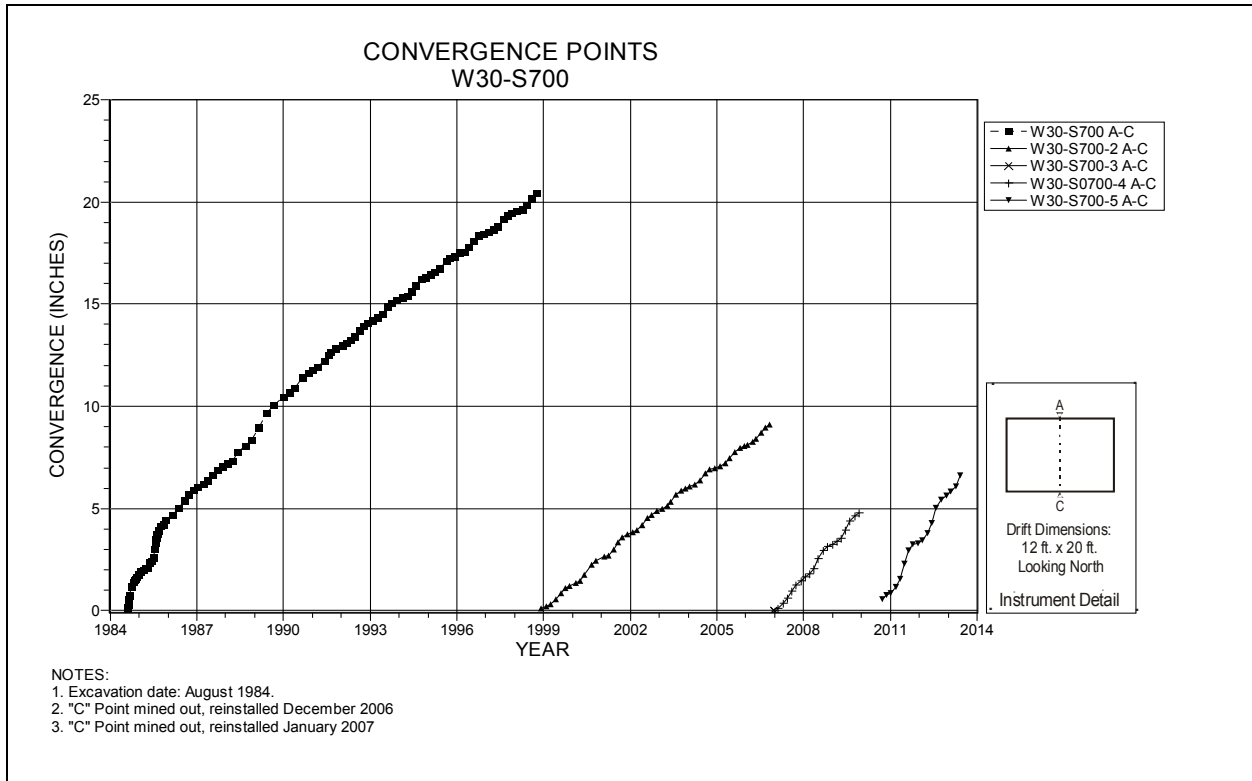

Figure 4-203 Convergence Point Array
W30 S700 – Roof to Floor

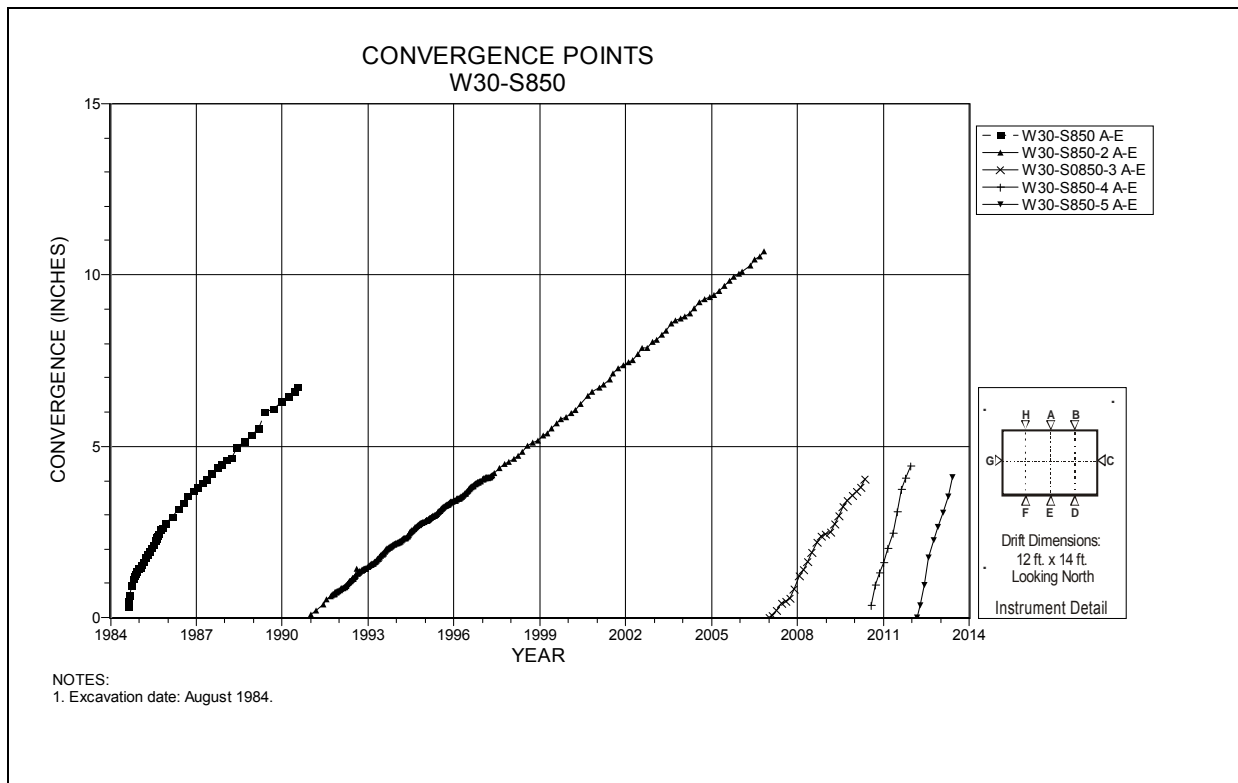

Figure 4-204 Convergence Point Array
W30 S850 – Roof to Floor – Centerline

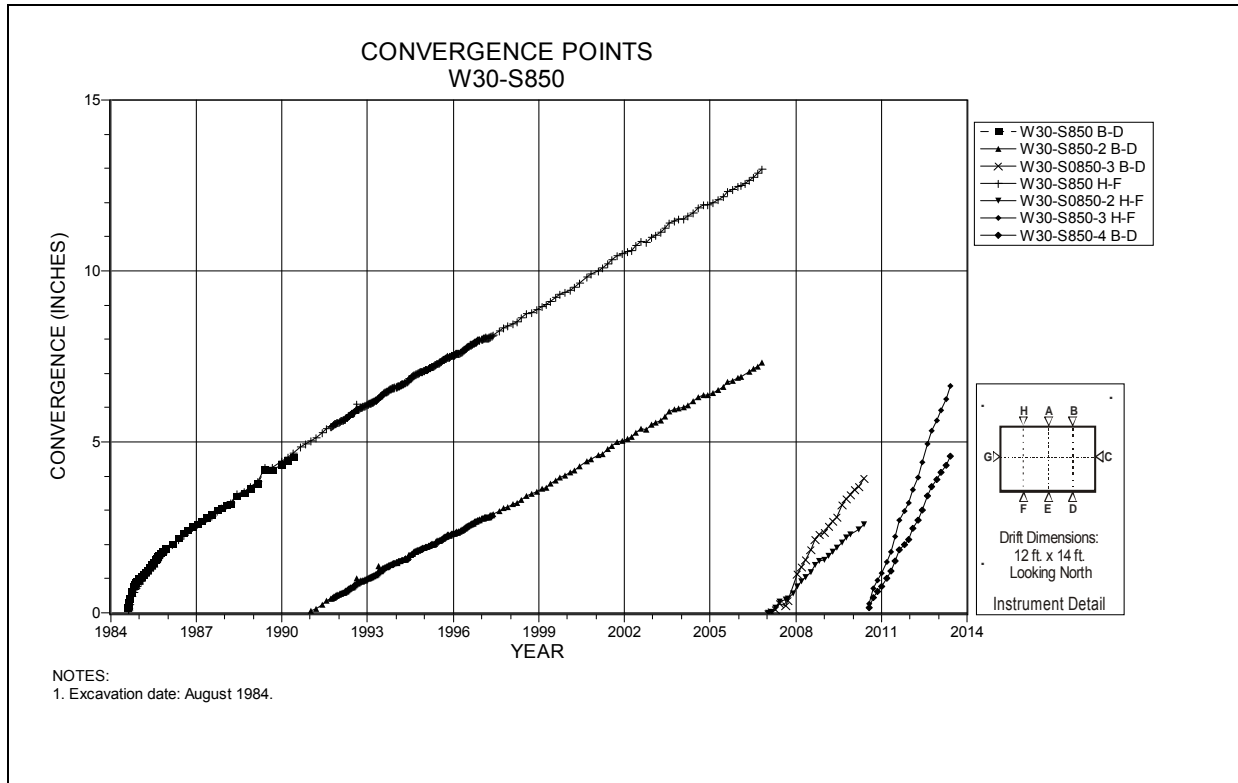

Figure 4-205 Convergence Point Array
W30 S850 – Roof to Floor – Quarter Points

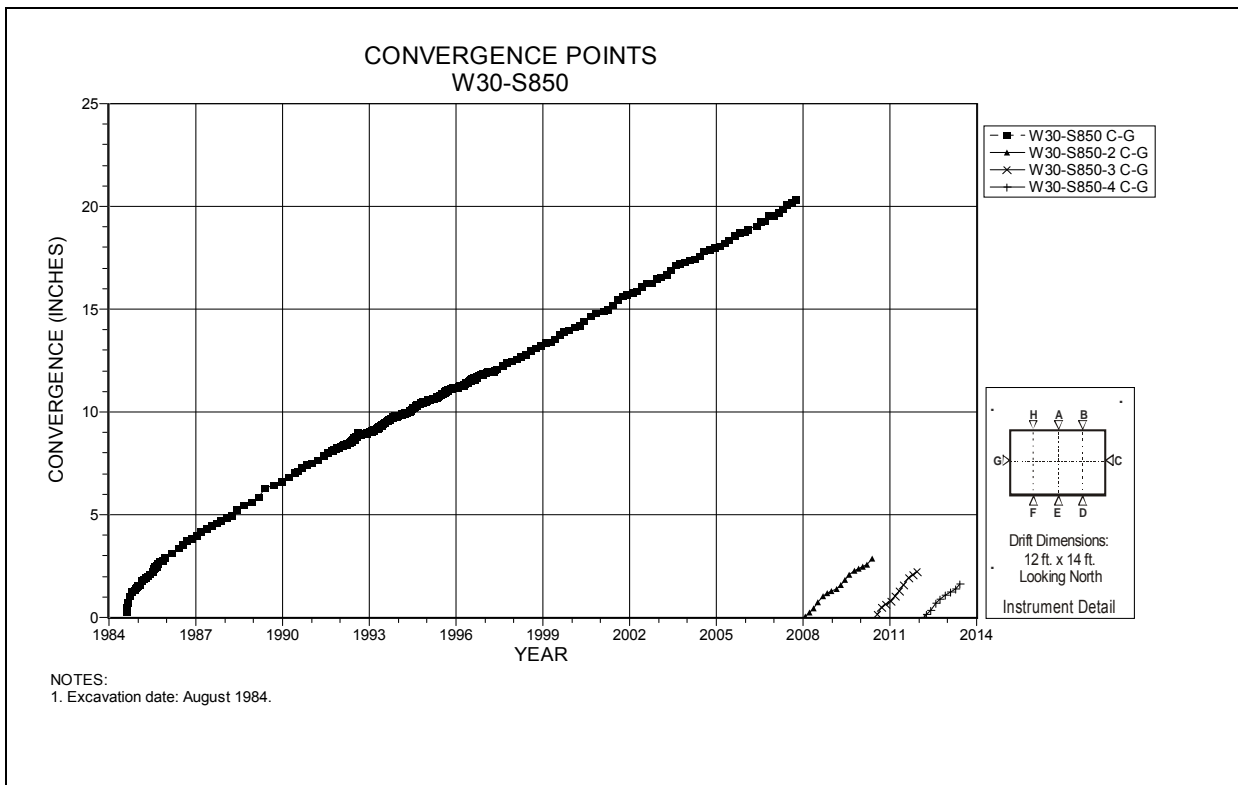

Figure 4-206 Convergence Point Array
W30 S850 – Rib to Rib

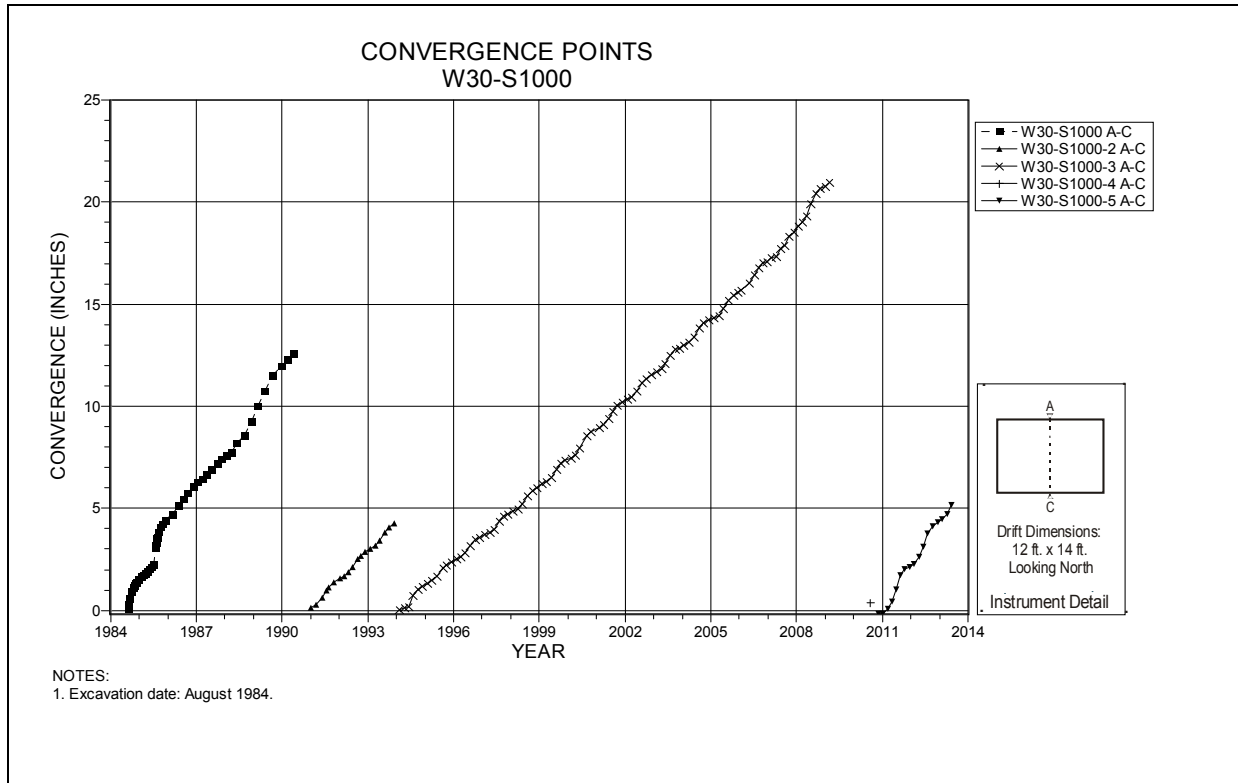

Figure 4-207 Convergence Point Array
W30 S1000 – Roof to Floor

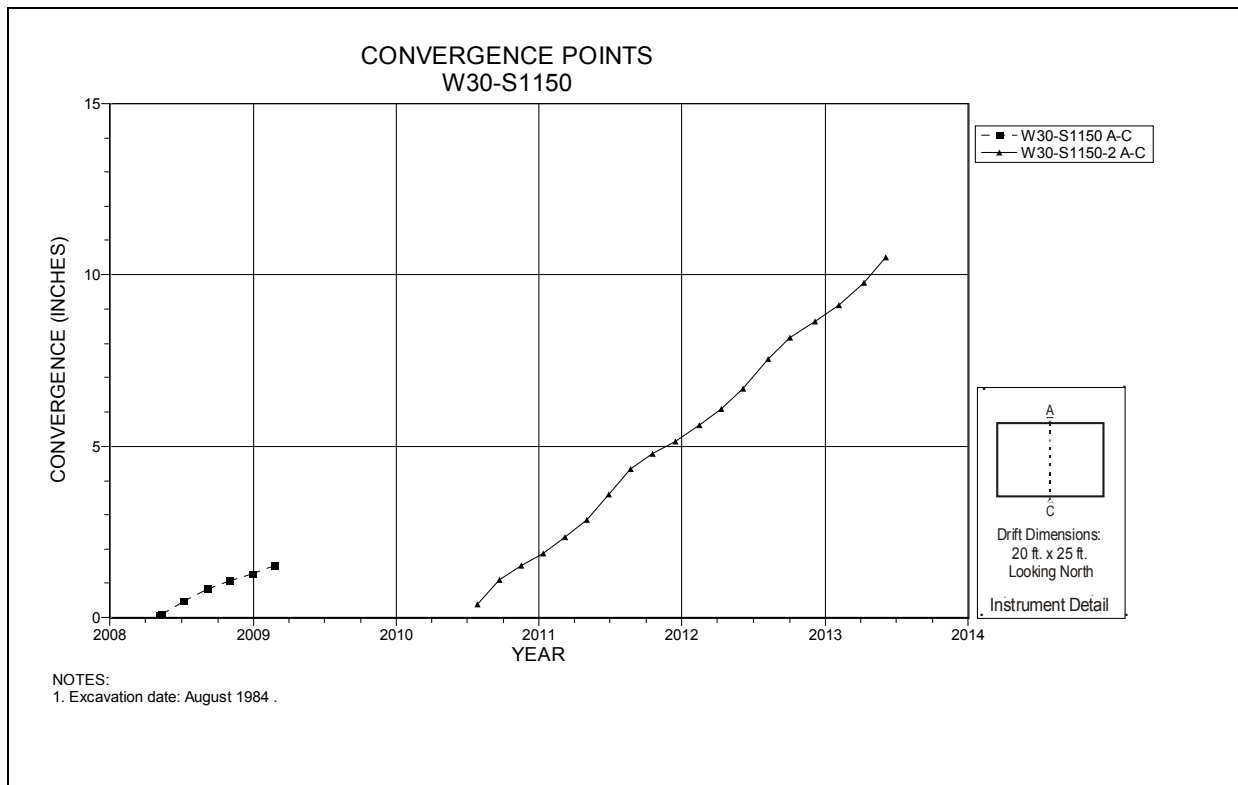

Figure 4-208 Convergence Point Array
W30 S1150 – Roof to Floor

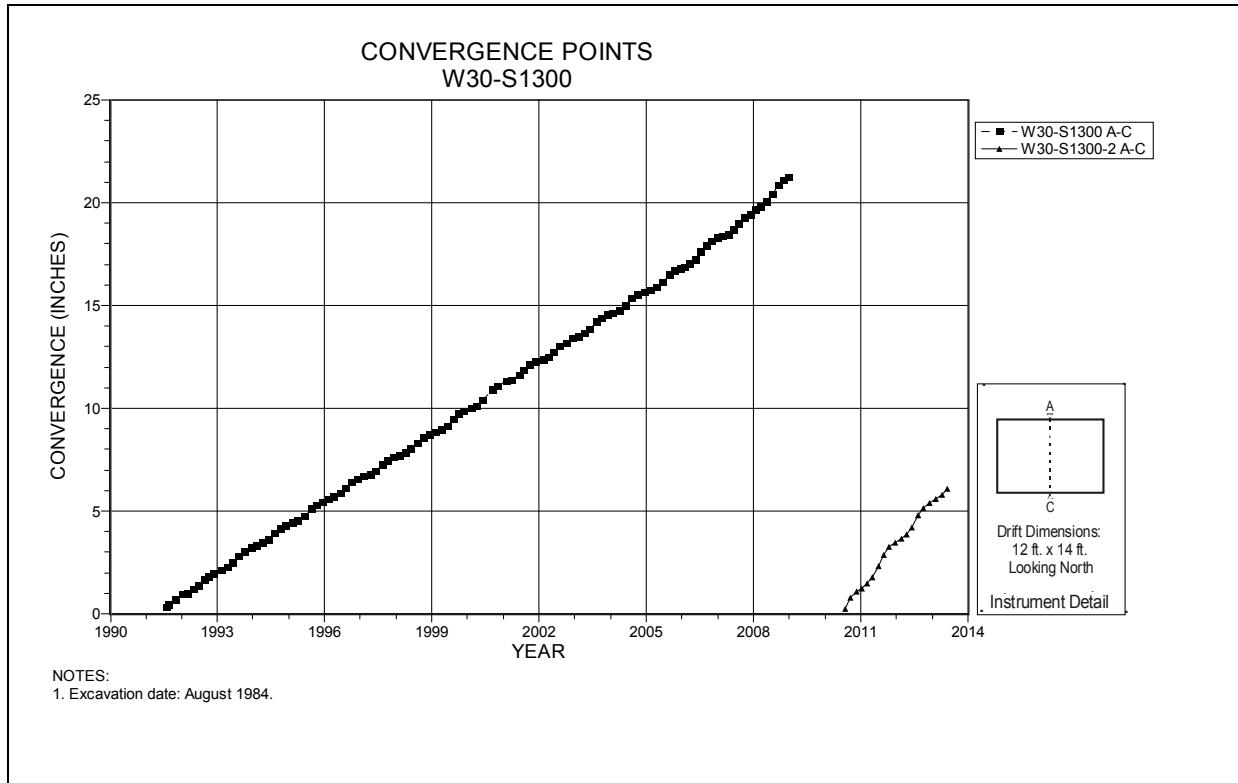

Figure 4-209 Convergence Point Array
W30 S1300 – Roof to Floor

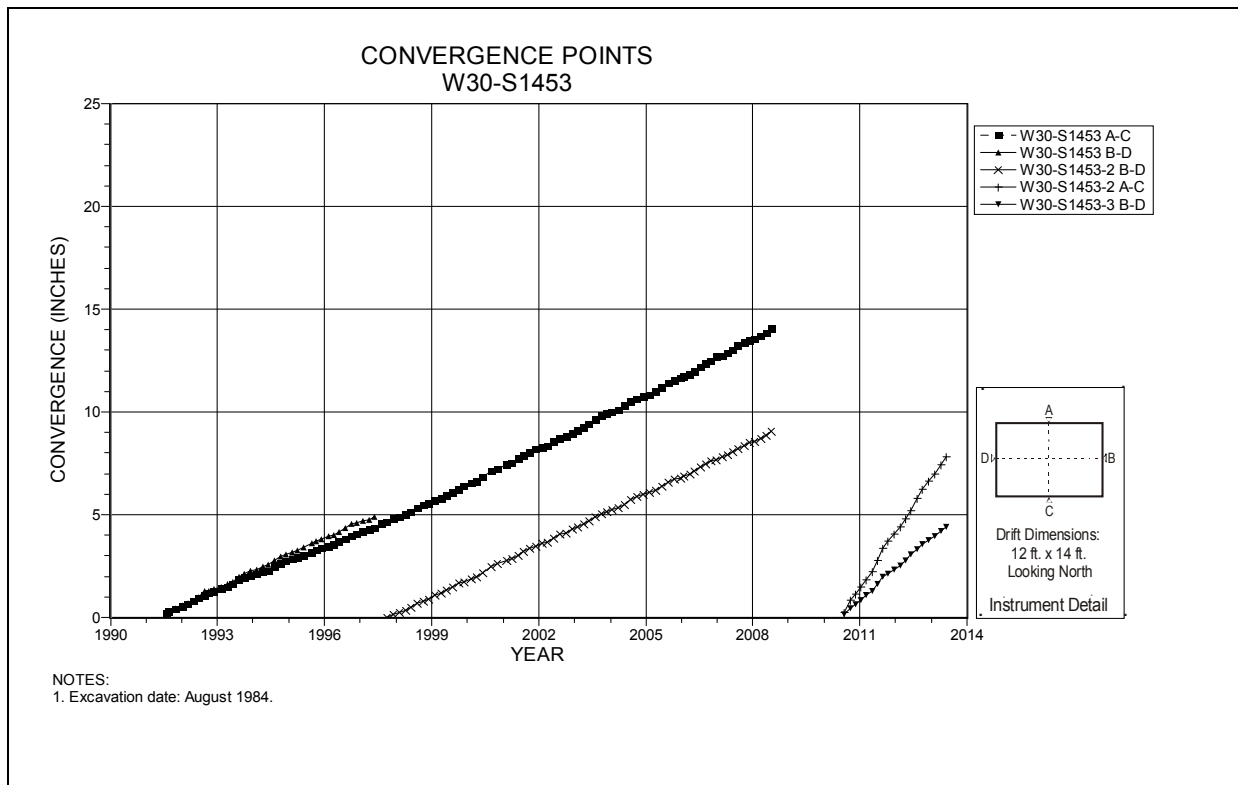

Figure 4-210 Convergence Point Array
W30 S1453 – All Chords

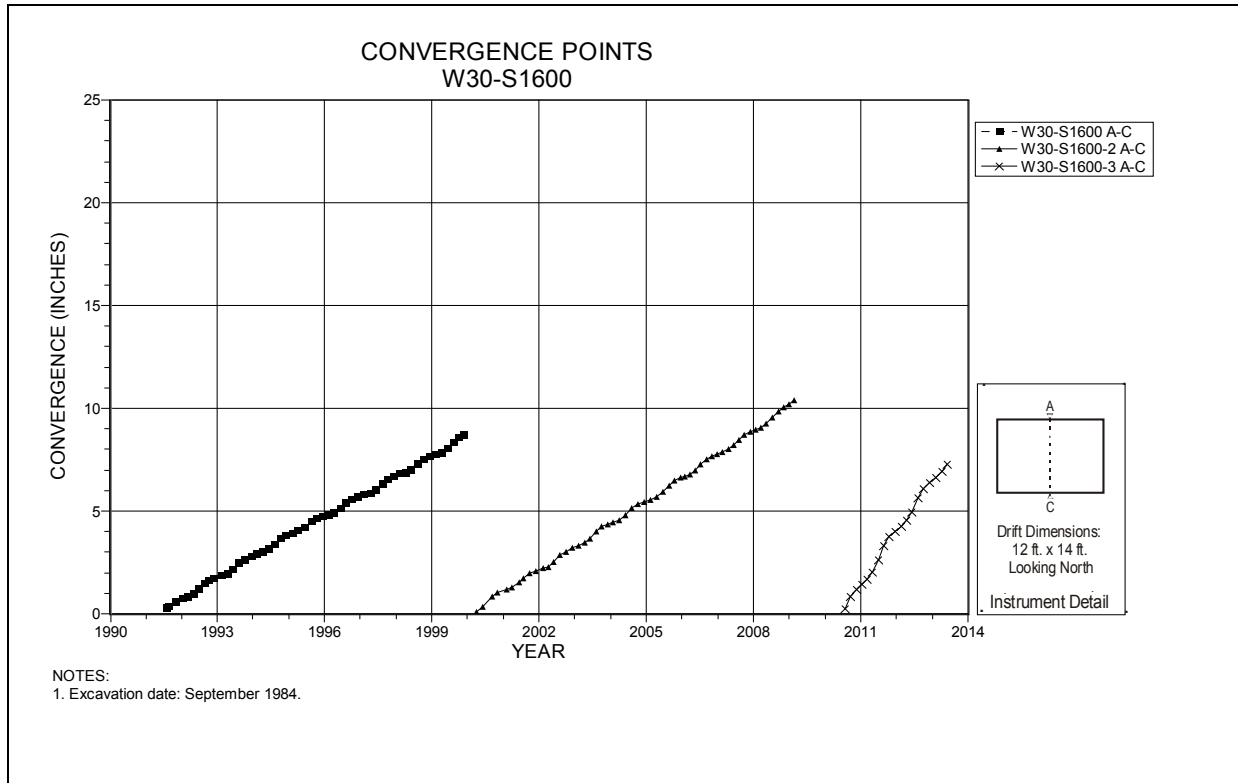

Figure 4-211 Convergence Point Array
W30 S1600 – Roof to Floor

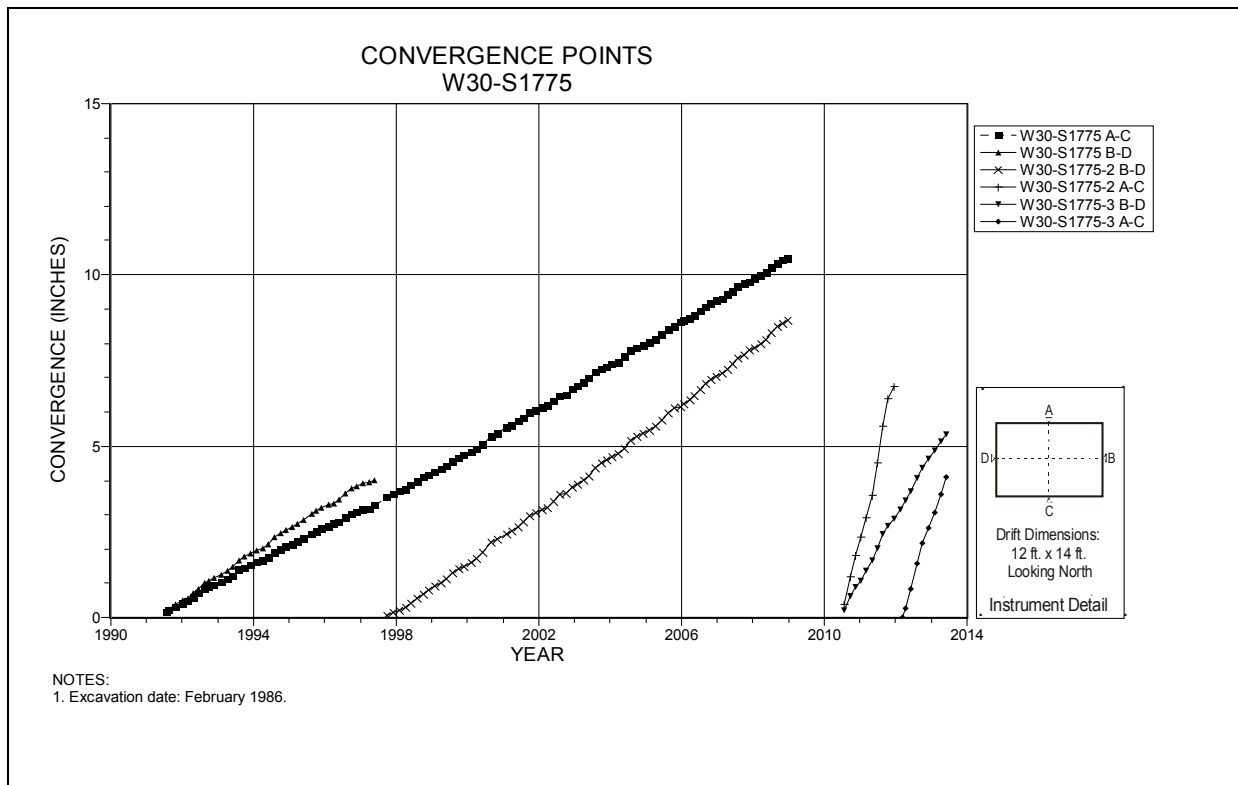

Figure 4-212 Convergence Point Array
W30 S1775 – All Chords

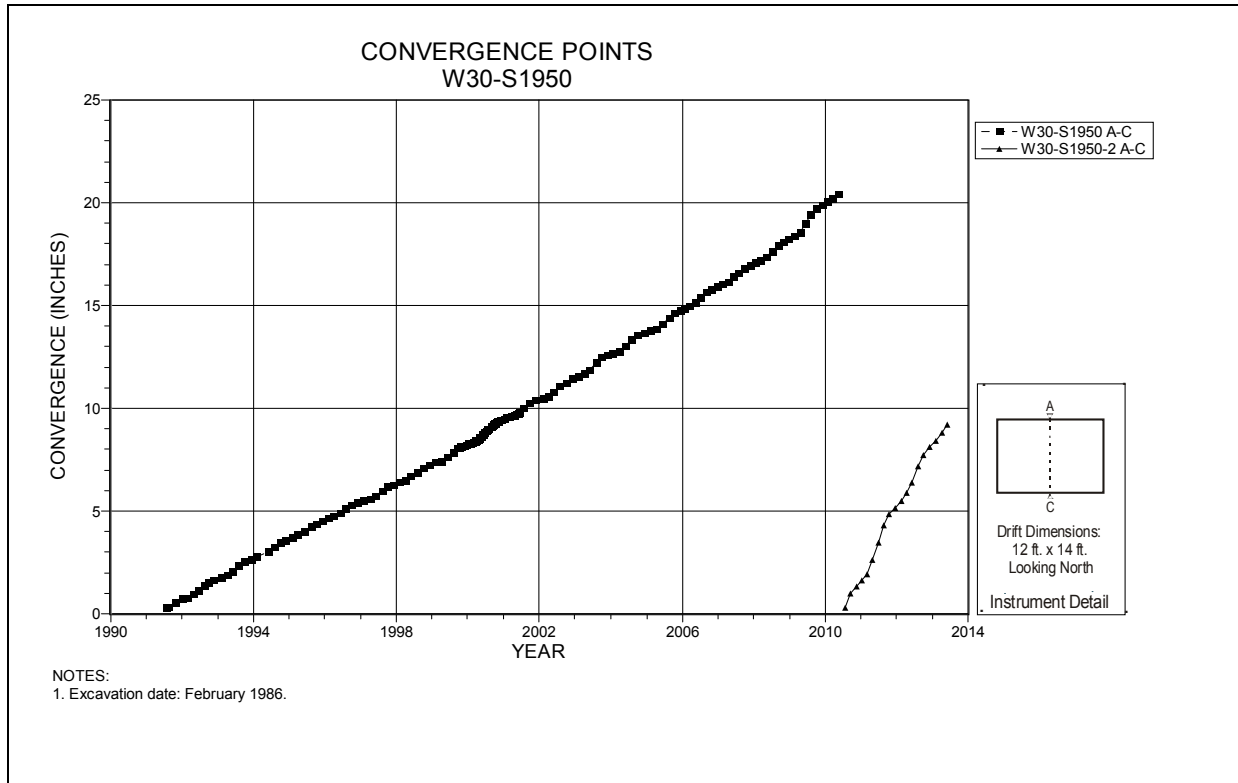

Figure 4-213 Convergence Point Array
W30 S1950 – Roof to Floor

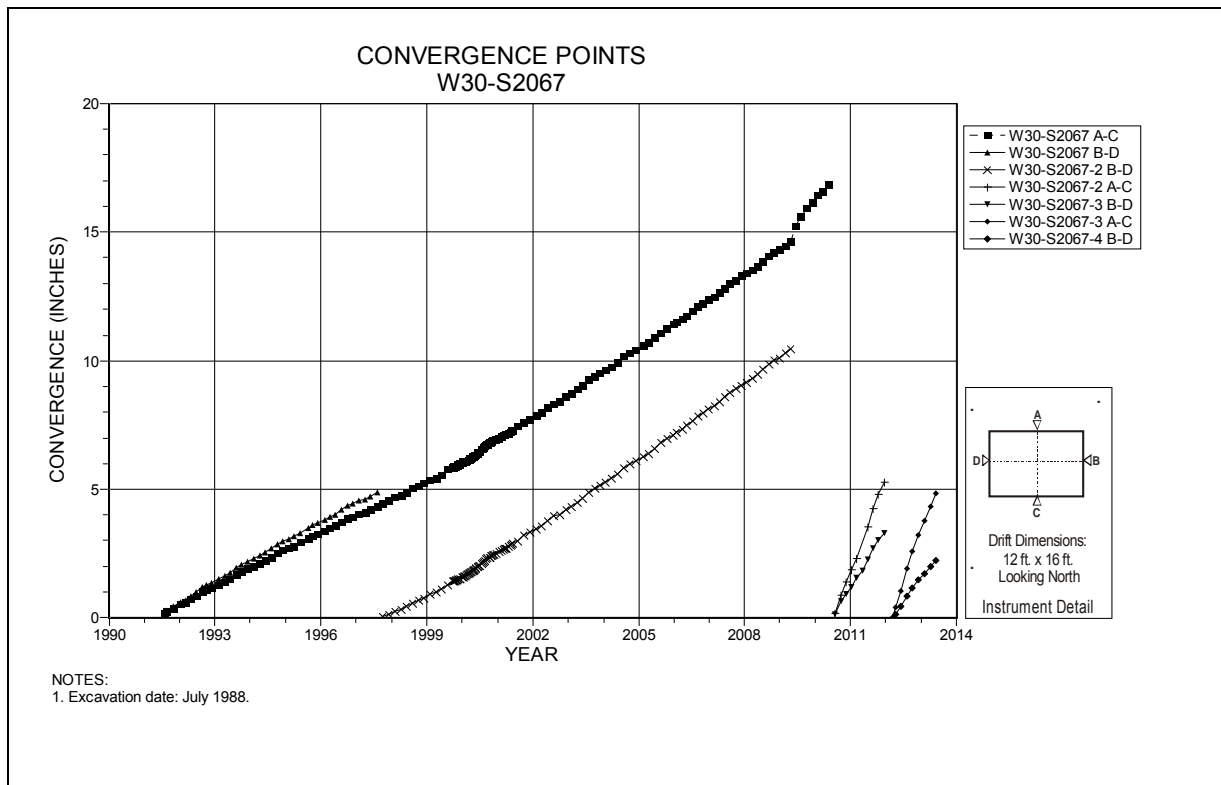

Figure 4-214 Convergence Point Array
W30 S2067 – All Chords

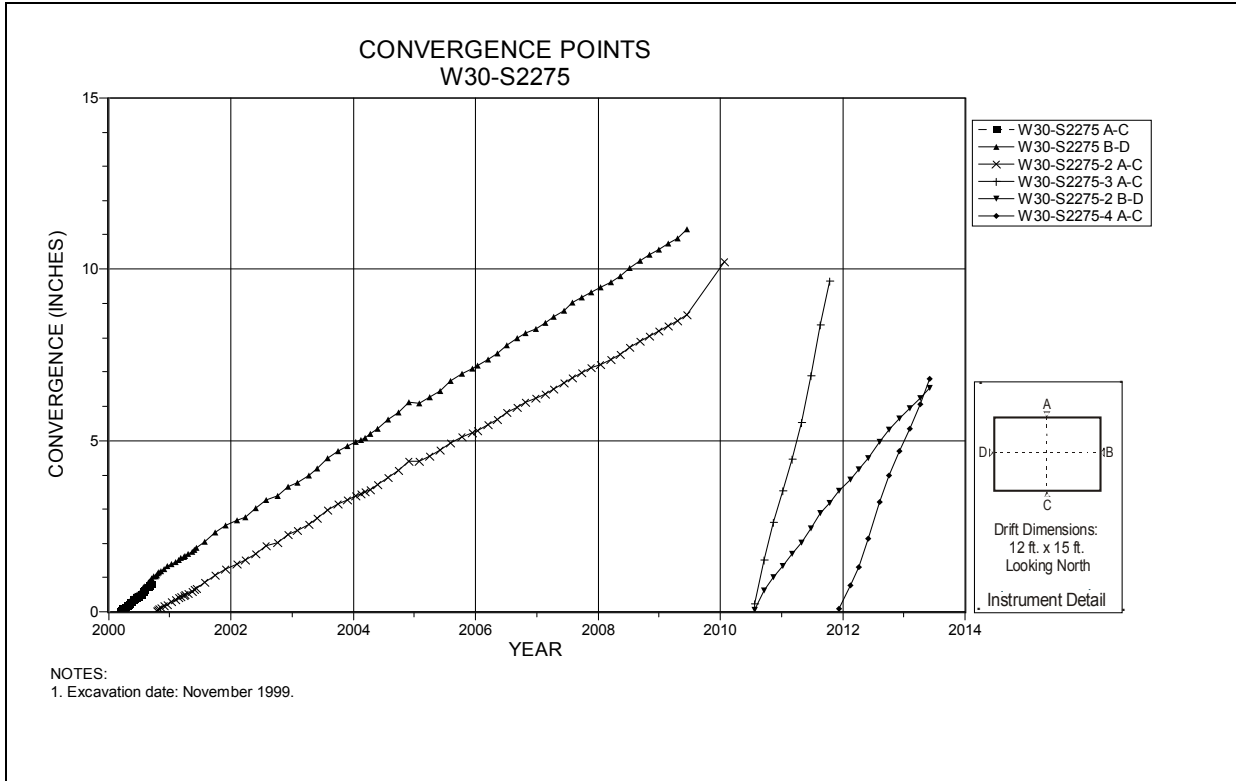

Figure 4-215 Convergence Point Array
W30 S2275 – All Chords

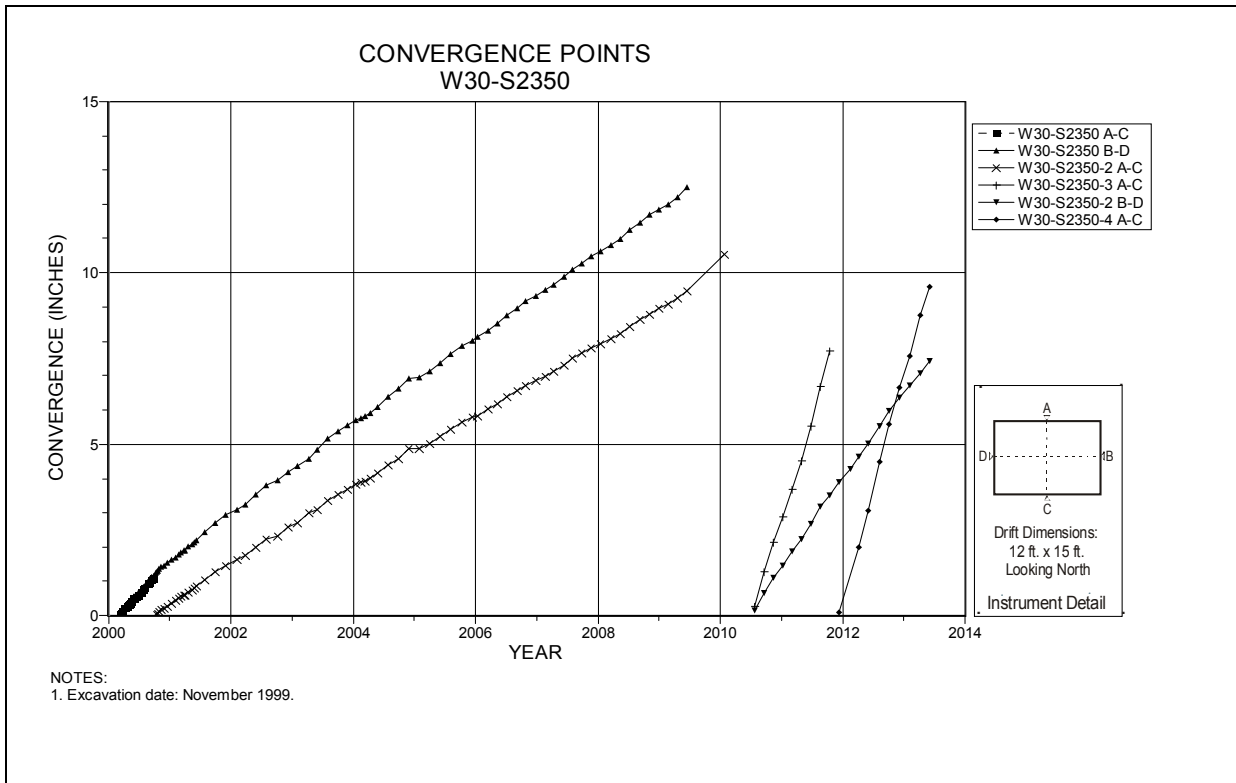

Figure 4-216 Convergence Point Array
W30 S2350 – All Chords

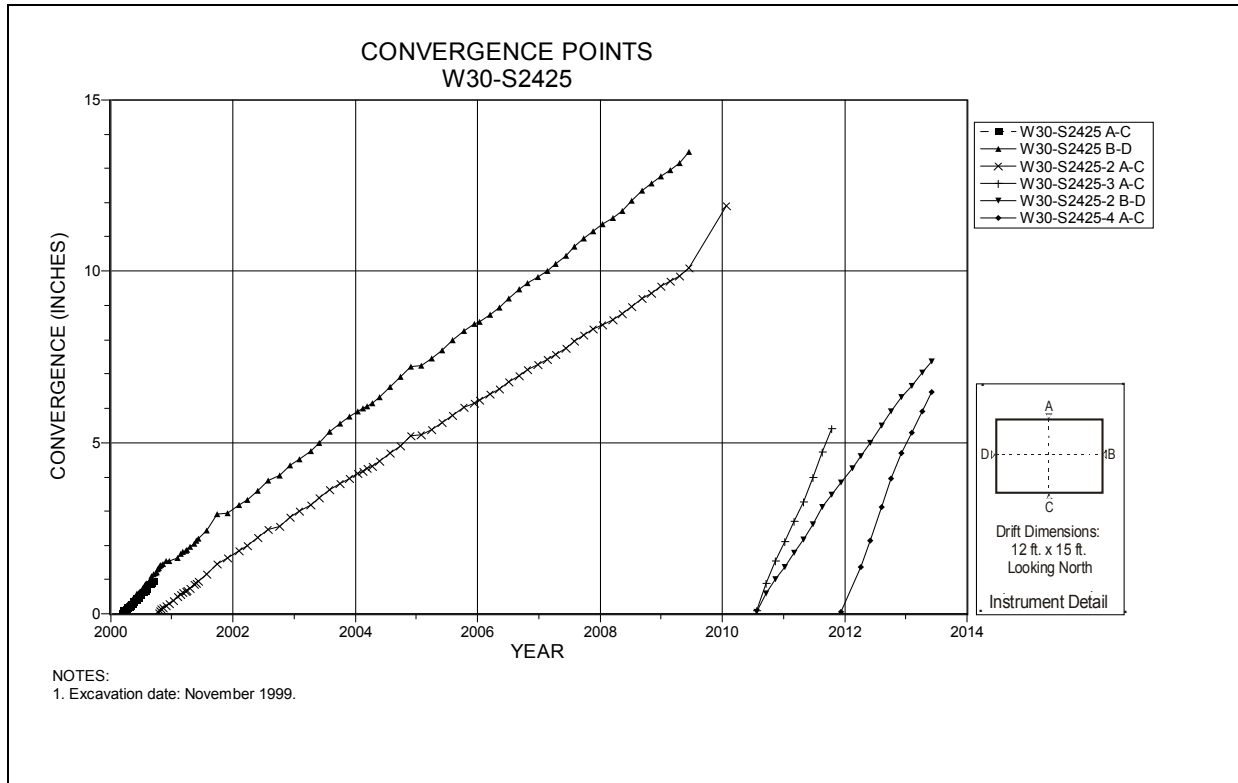

Figure 4-217 Convergence Point Array
W30 S2425 – All Chords

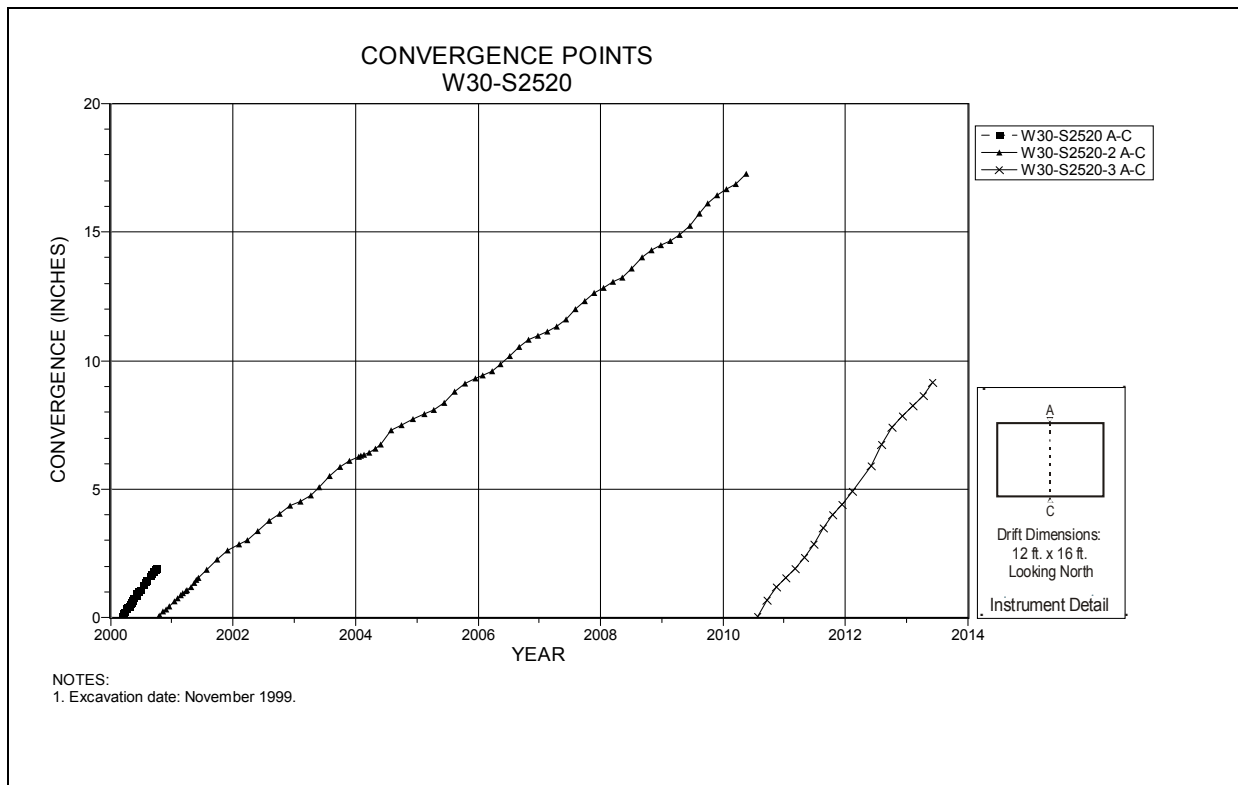

Figure 4-218 Convergence Point Array
W30 S2520 – Roof to Floor

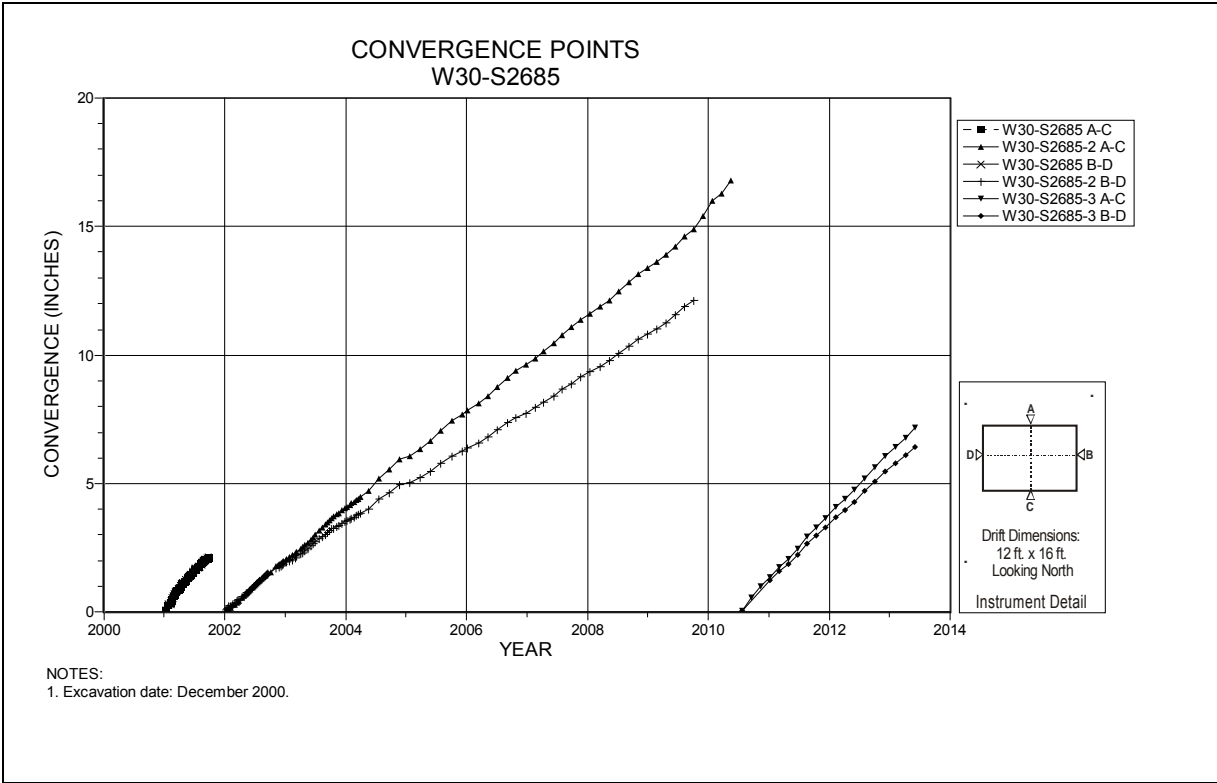

Figure 4-219 Convergence Point Array
W30 S2685 – All Chords

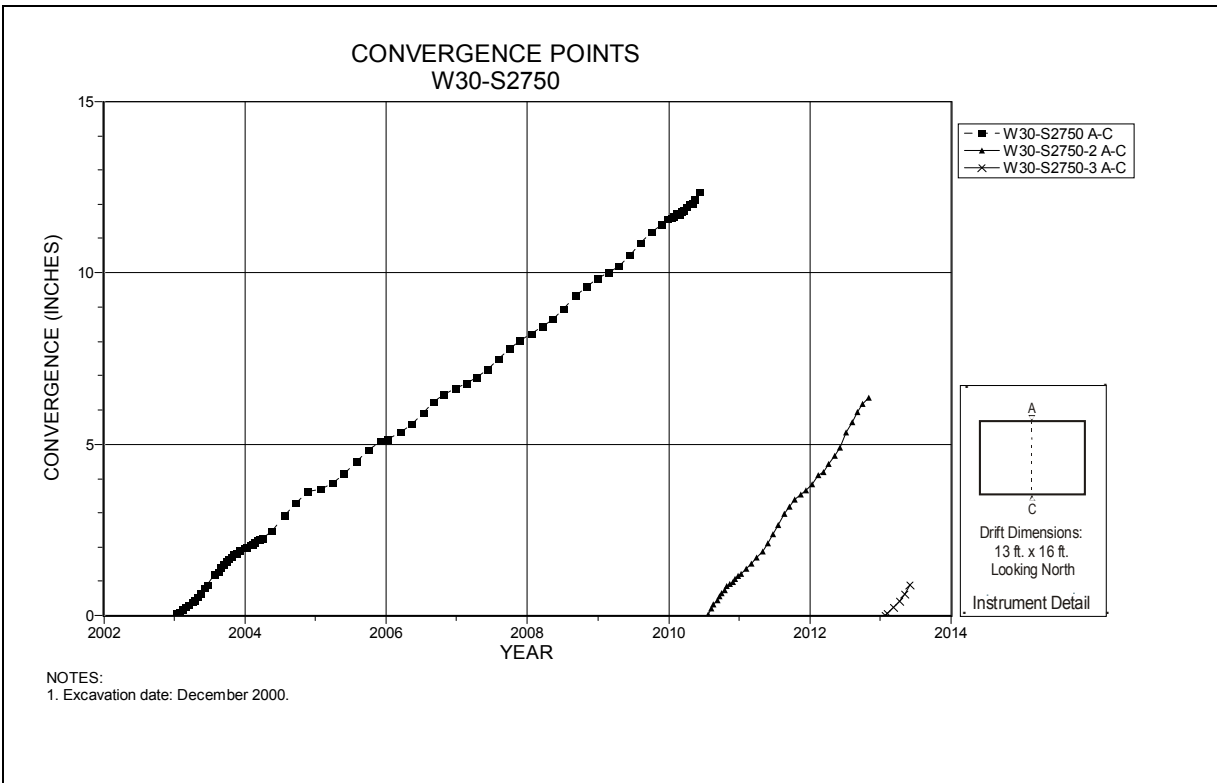

Figure 4-220 Convergence Point Array
W30 S2750 – Roof to Floor

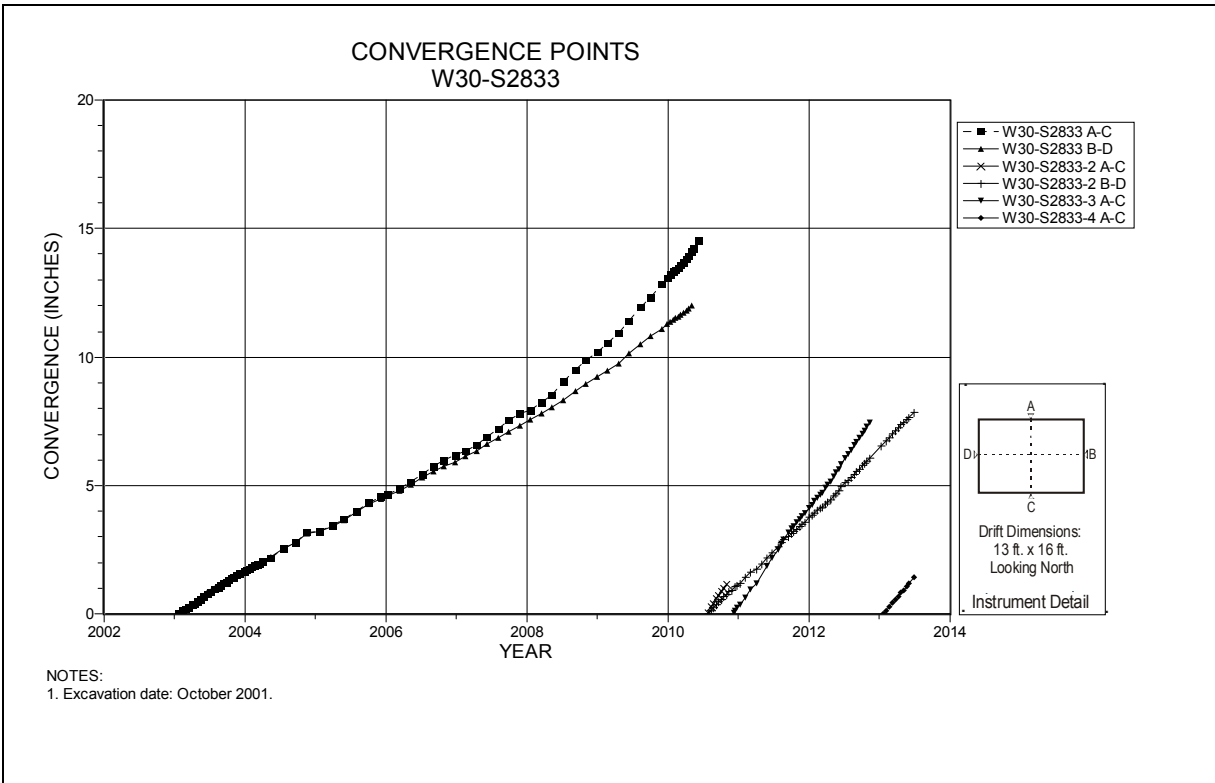

Figure 4-221 Convergence Point Array
W30 S2833 – All Chords

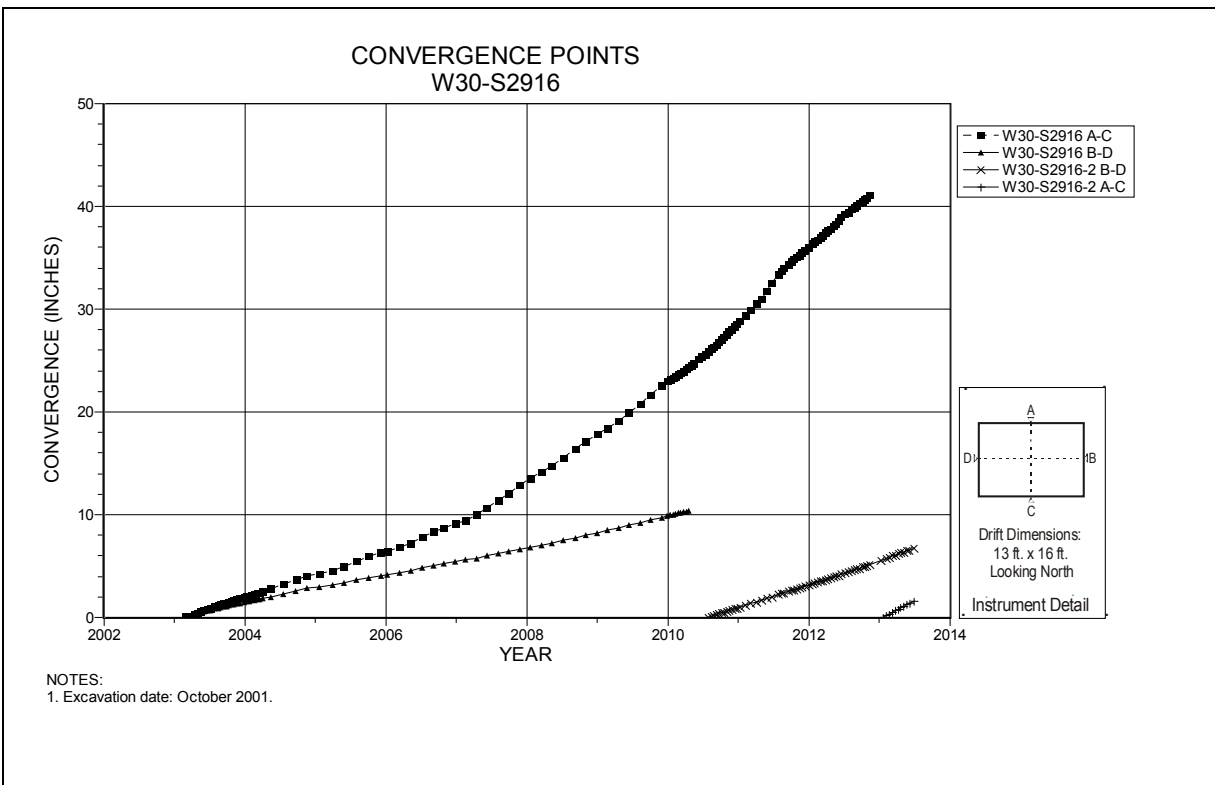

Figure 4-222 Convergence Point Array
W30 S2916 – All Chords

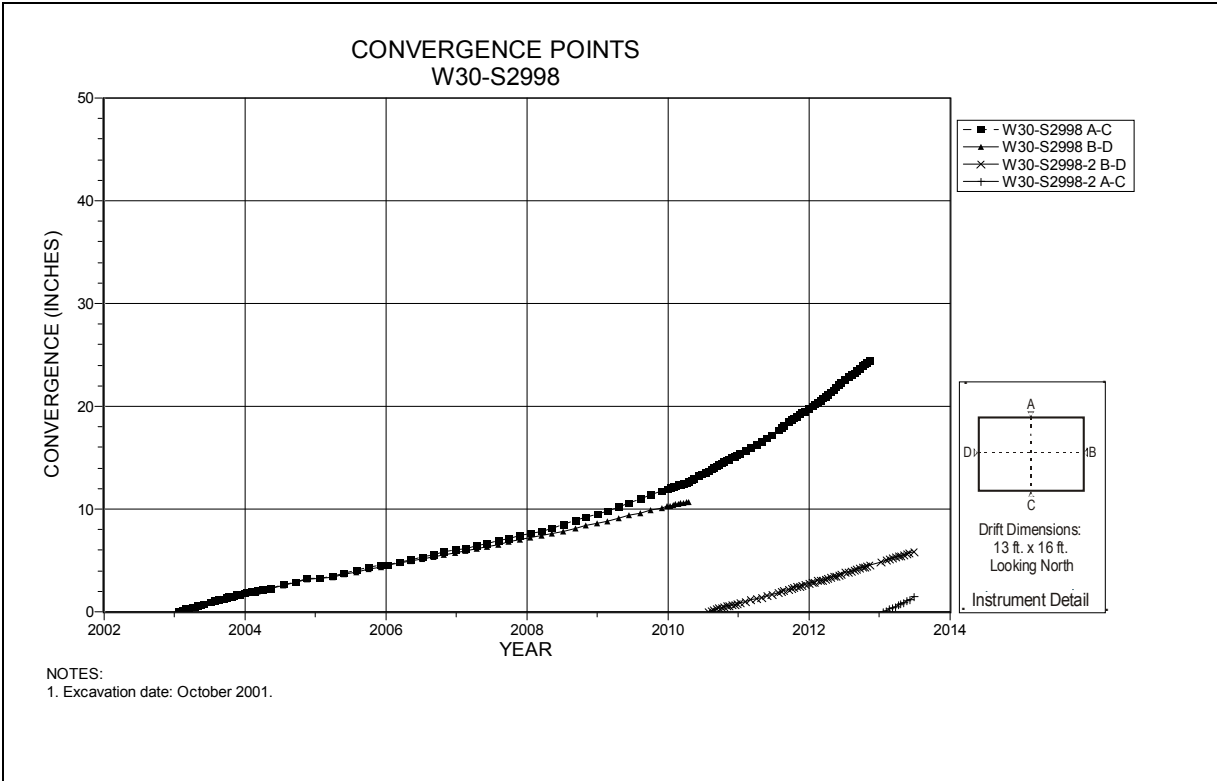

Figure 4-223 Convergence Point Array
W30 S2998 – All Chords

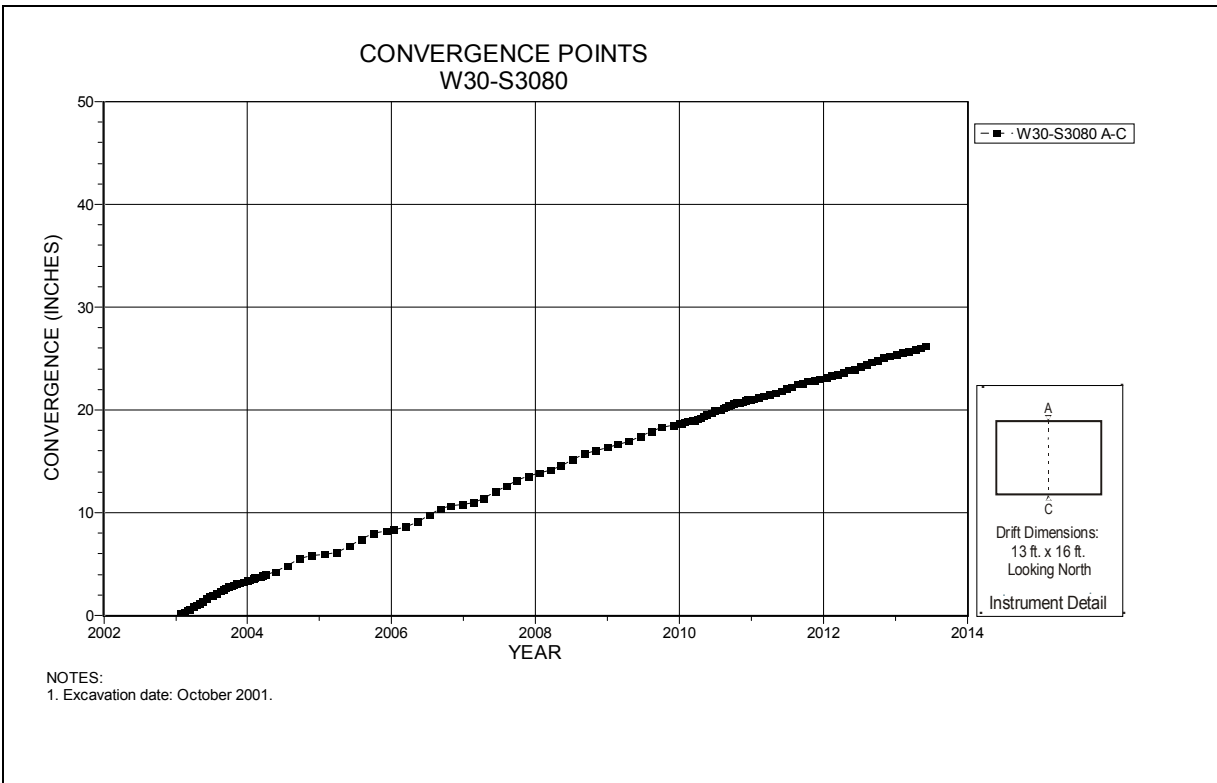

Figure 4-224 Convergence Point Array
W30 S3080 – Roof to Floor

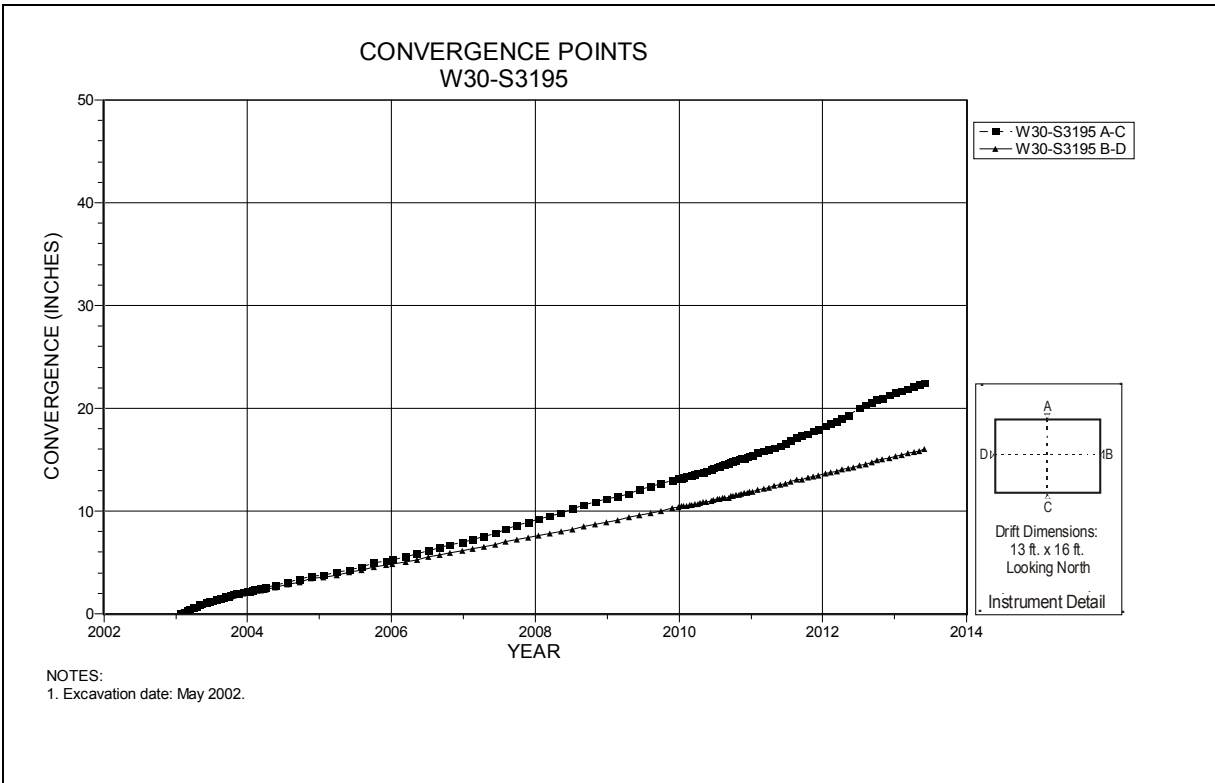

Figure 4-225 Convergence Point Array
W30 S3195 – All Chords

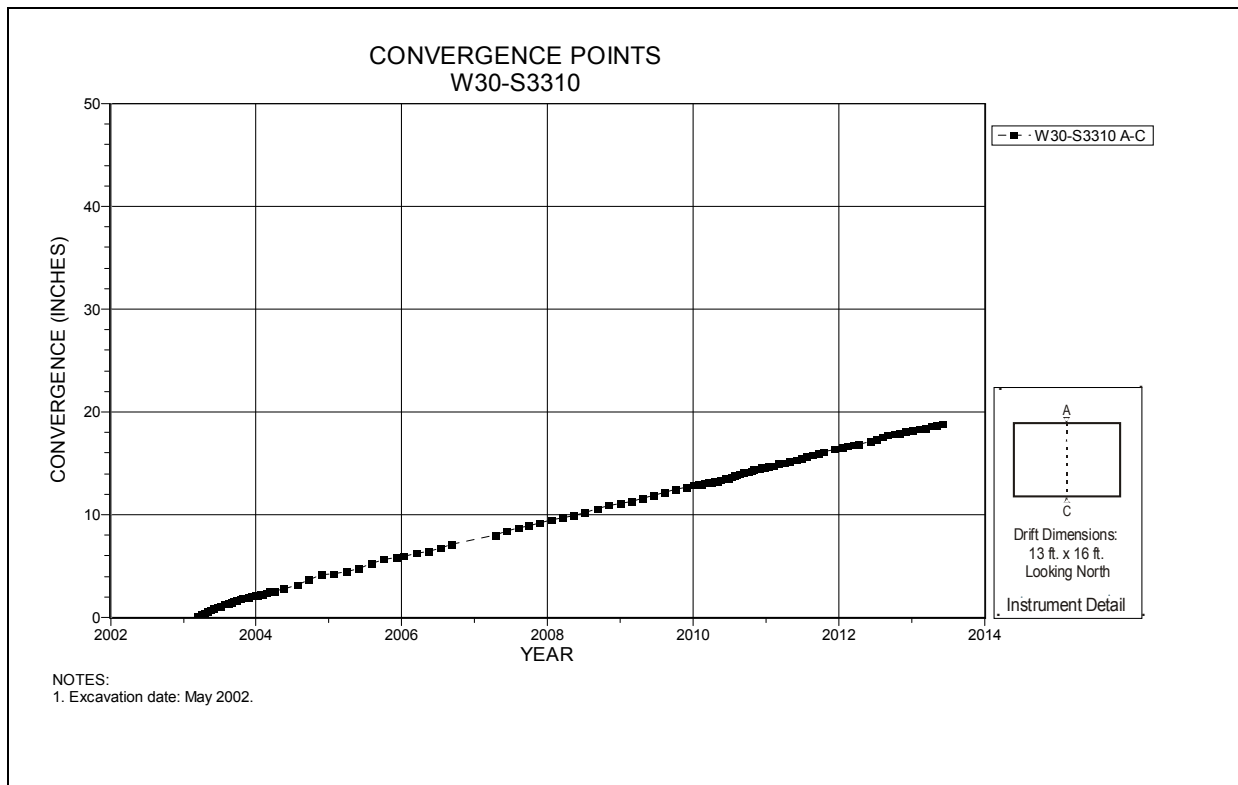

Figure 4-226 Convergence Point Array
W30 S3310 – Roof to Floor

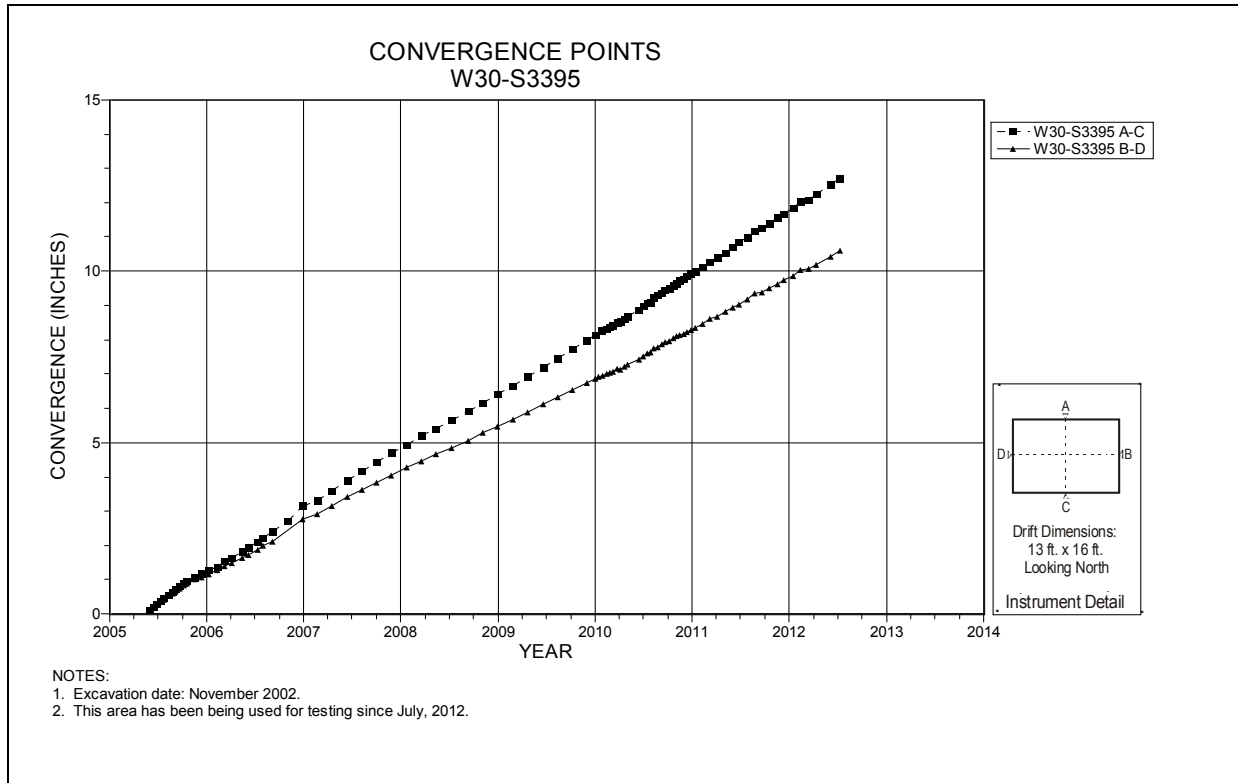

Figure 4-227 Convergence Point Array
W30 S3395 – All Chords

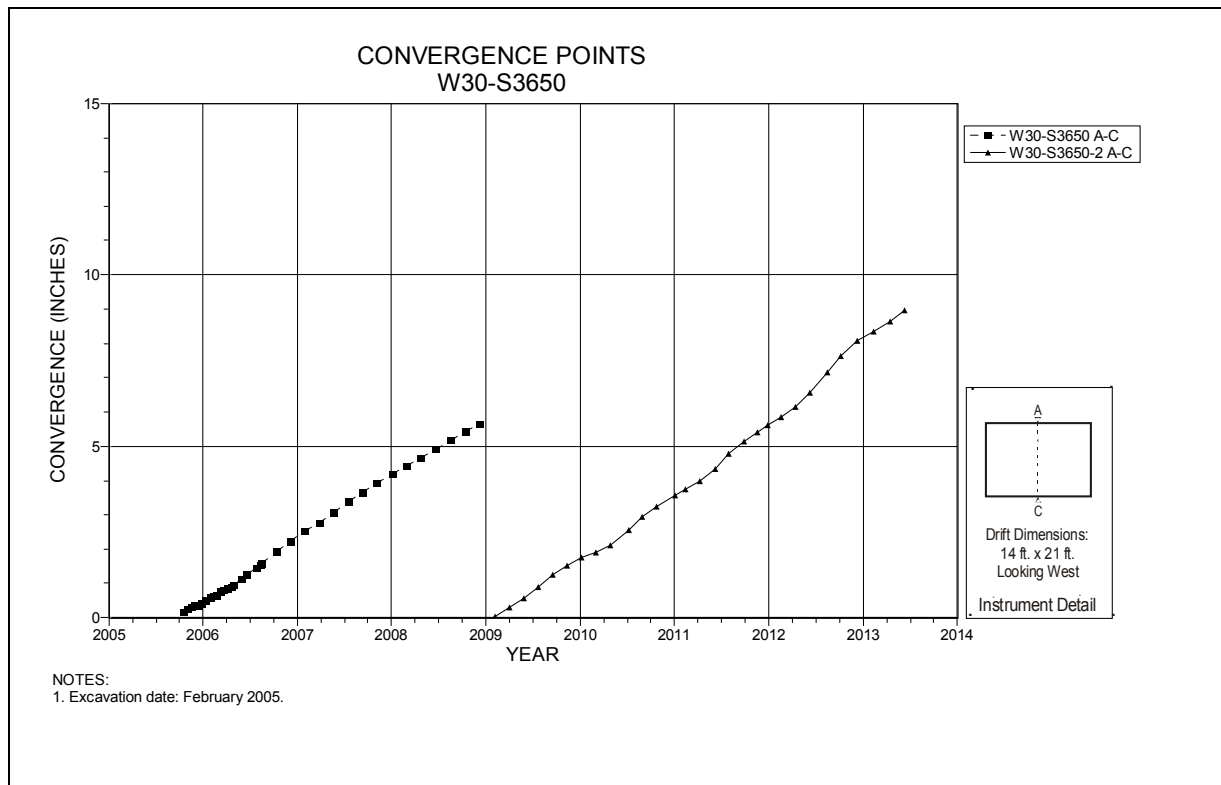

Figure 4-228 Convergence Point Array
W30 S3650 – Roof to Floor

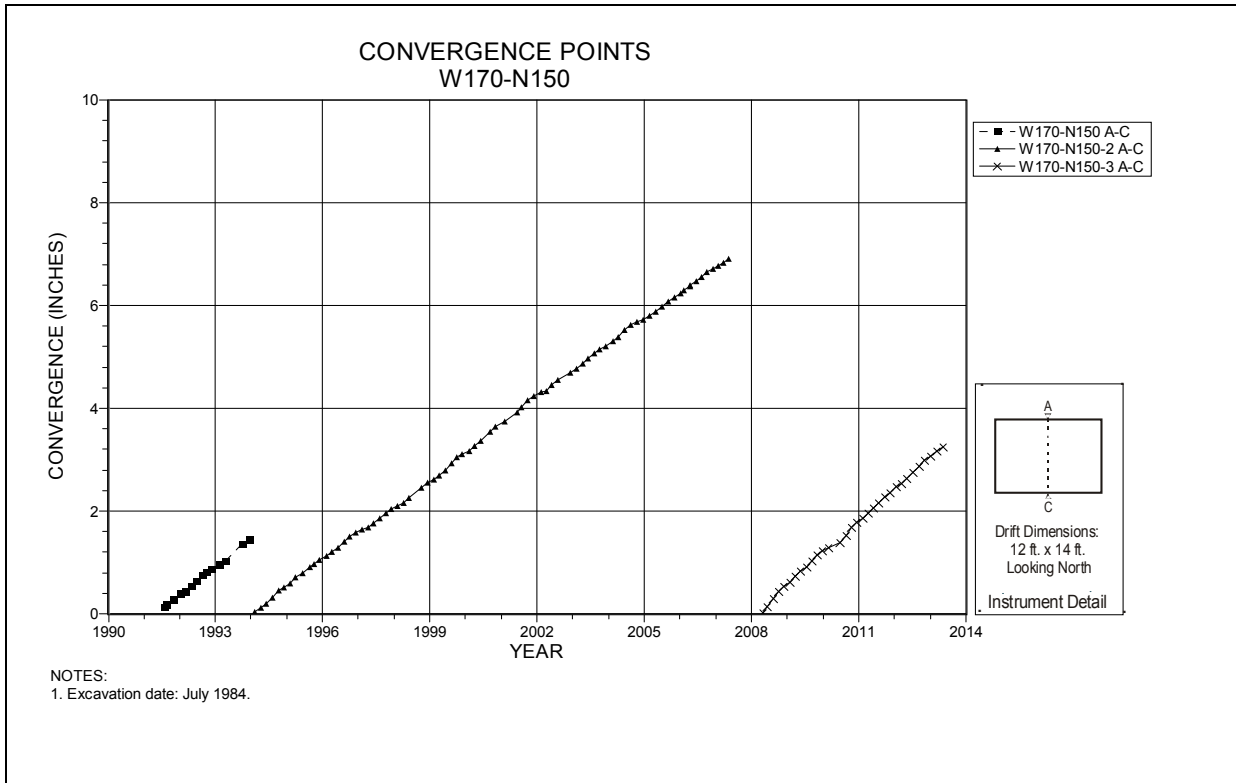

Figure 4-229 Convergence Point Array
W170 N150 – Roof to Floor

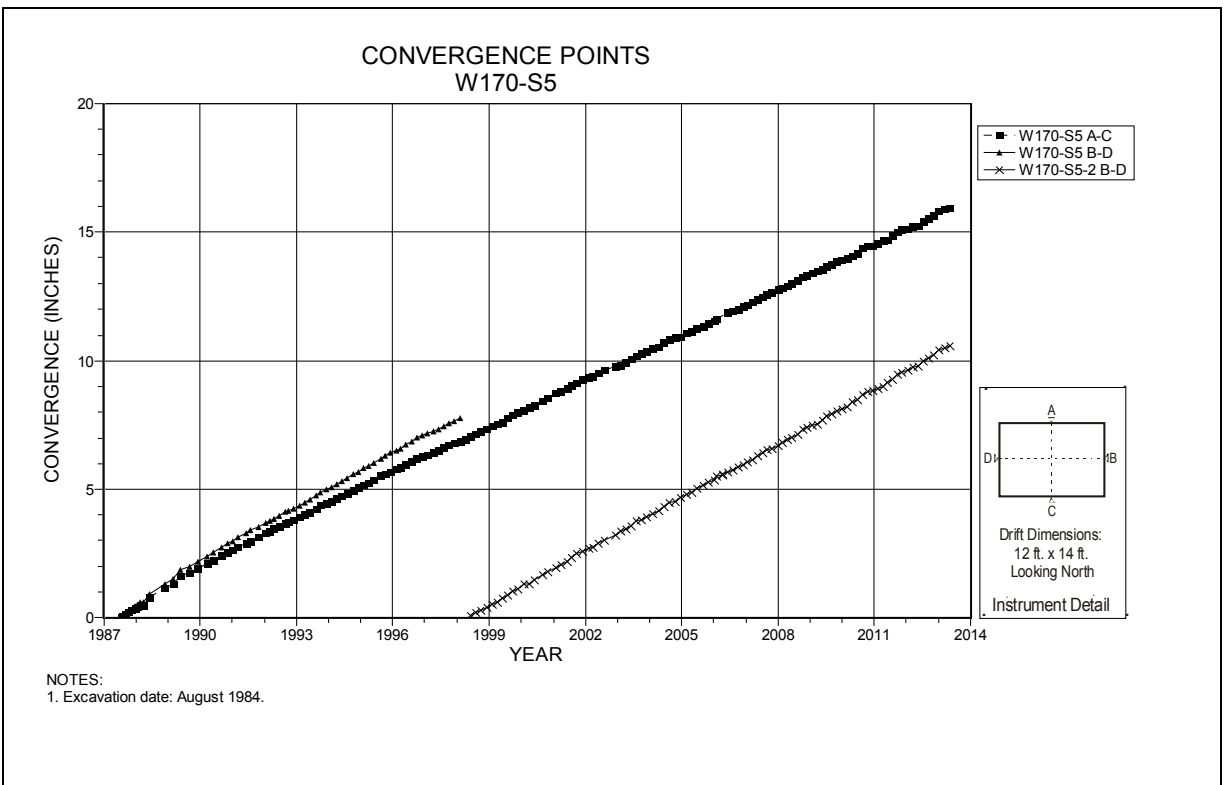

Figure 4-230 Convergence Point Array
W170 S5 – All Chords

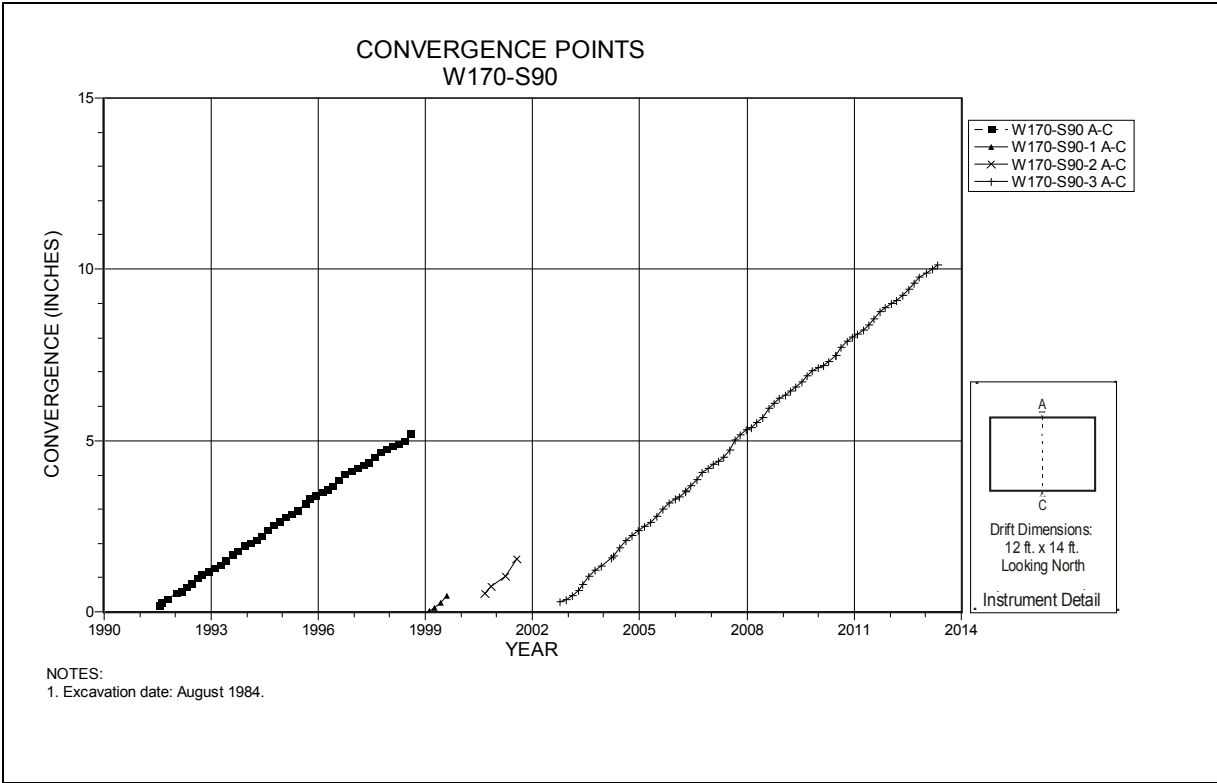

Figure 4-231 Convergence Point Array
W170 S90 – Roof to Floor

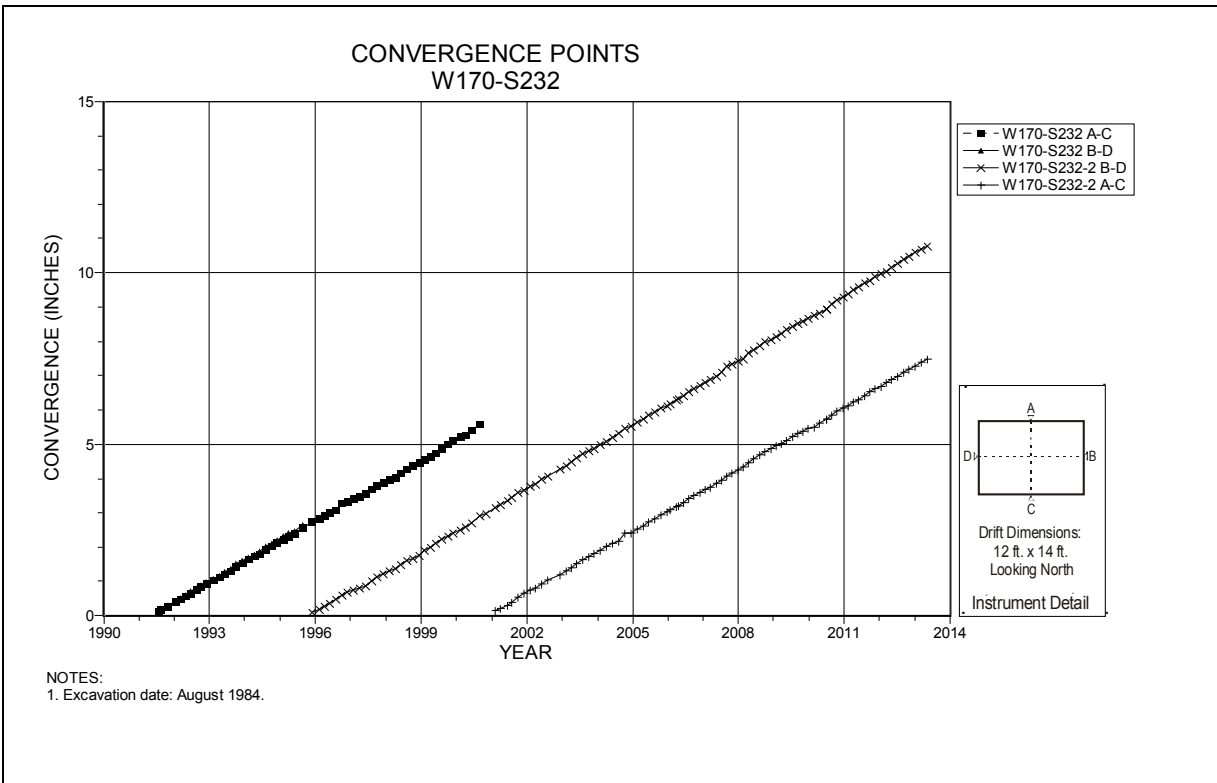

Figure 4-232 Convergence Point Array
W170 S232 – All Chords

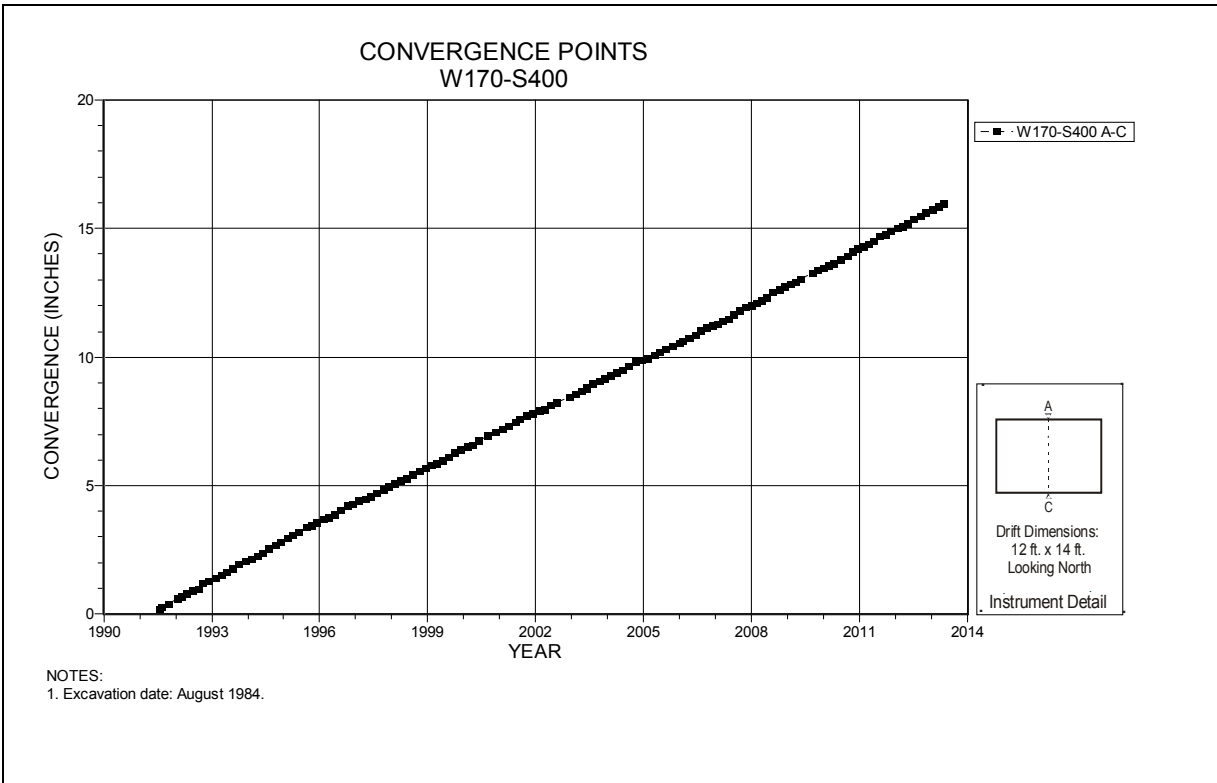

Figure 4-233 Convergence Point Array
W170 S400 – Roof to Floor

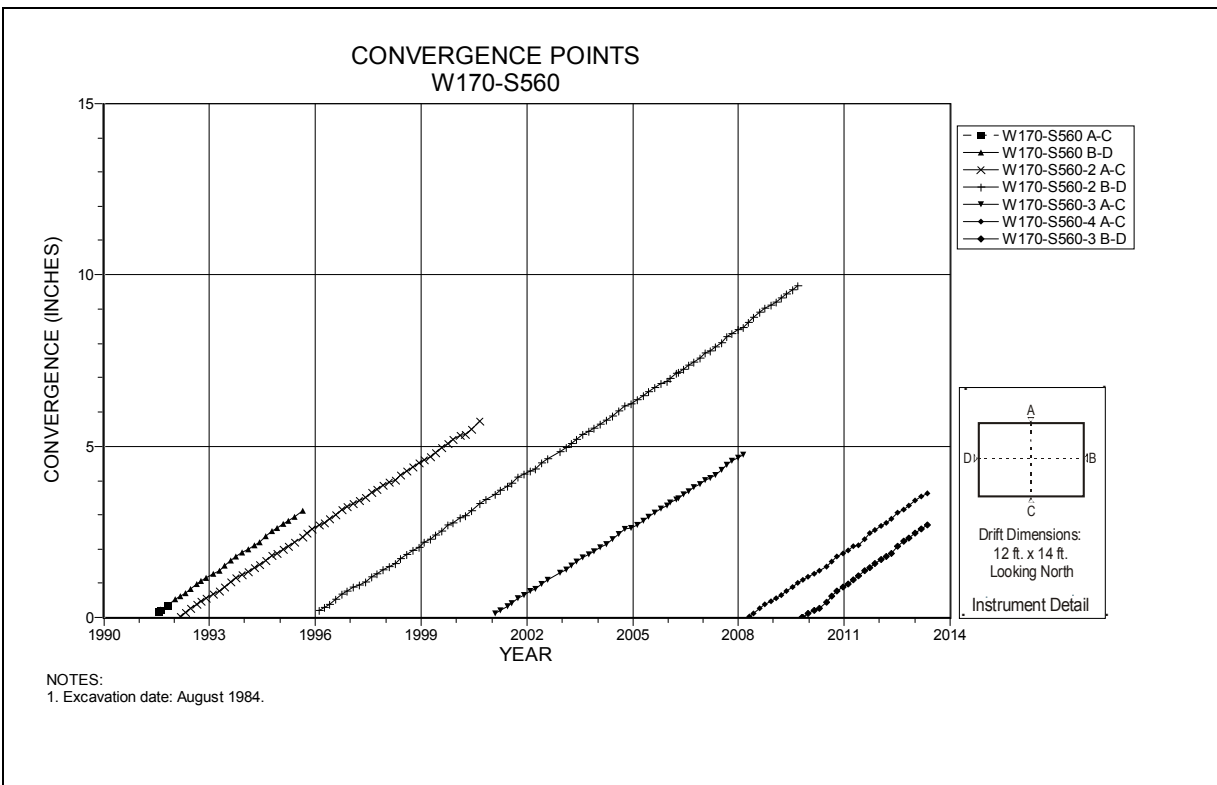

Figure 4-234 Convergence Point Array
W170 S560 – All Chords

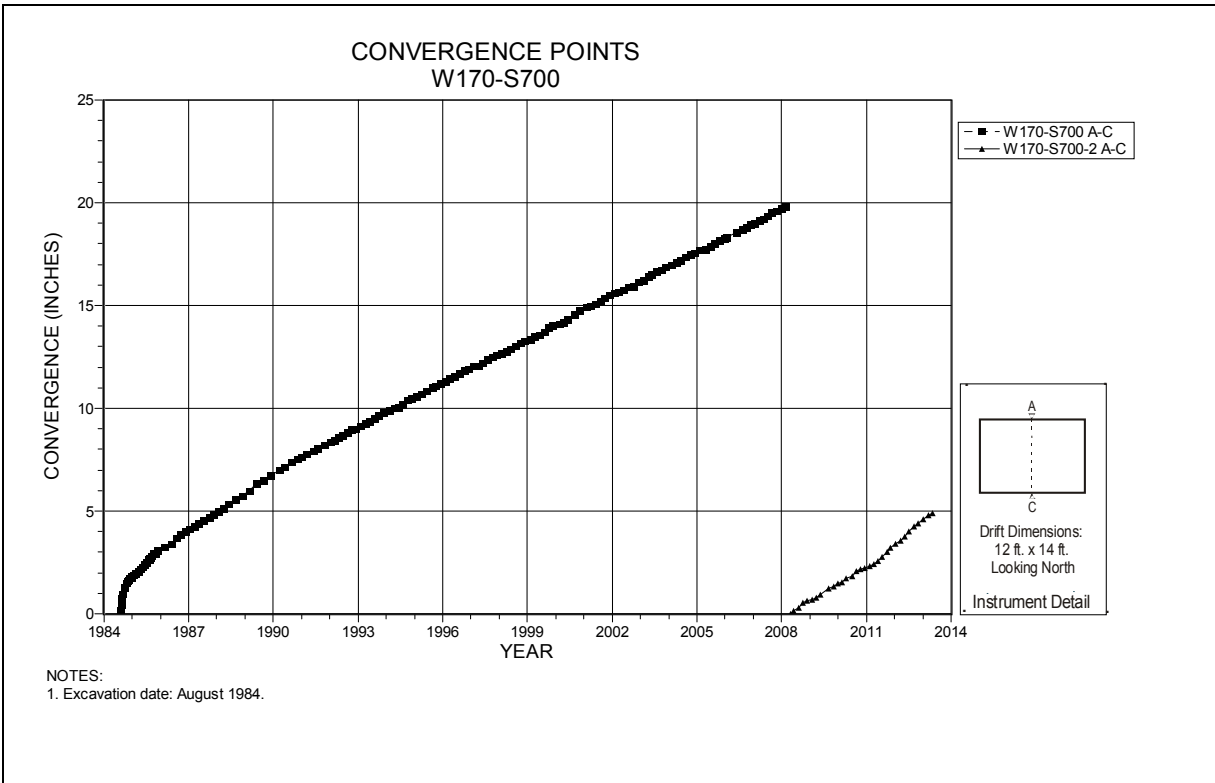

Figure 4-235 Convergence Point Array
W170 S700 – Roof to Floor

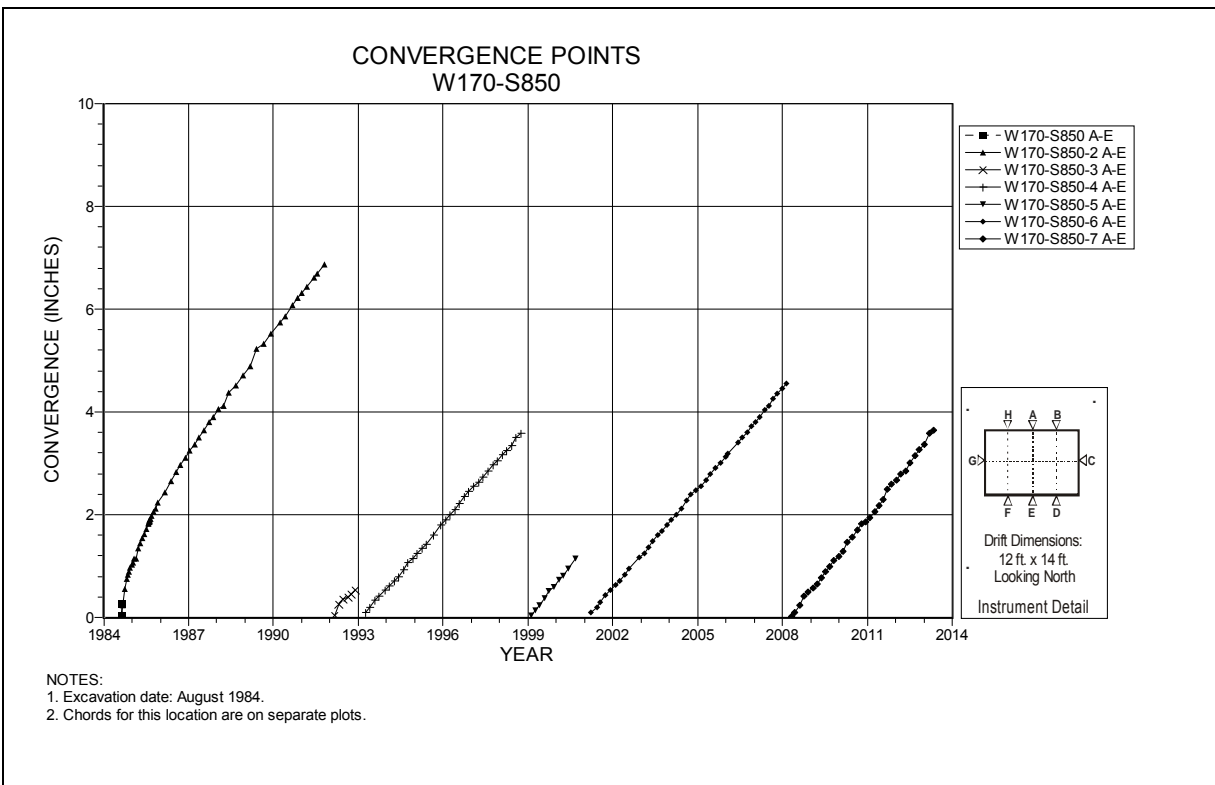

Figure 4-236 Convergence Point Array
W170 S850 – Roof to Floor – Centerline

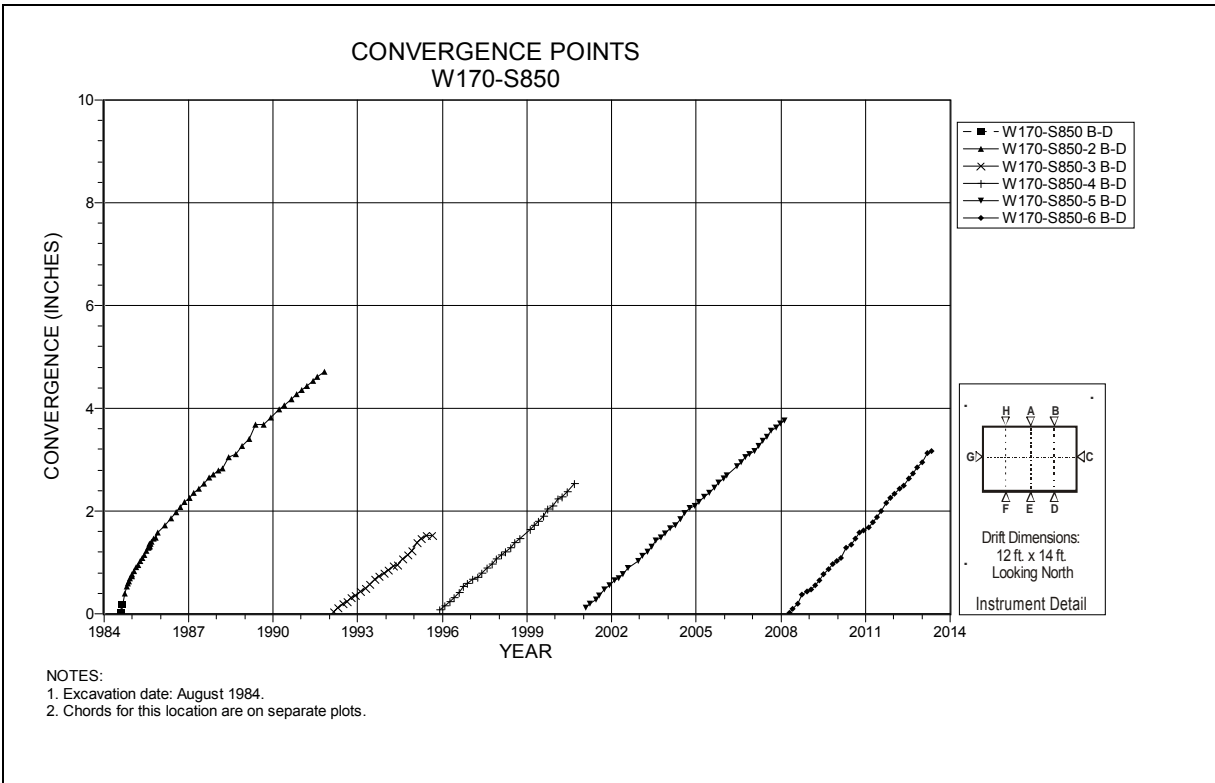

Figure 4-237 Convergence Point Array
W170 S850 – Roof to Floor – East Quarter Point

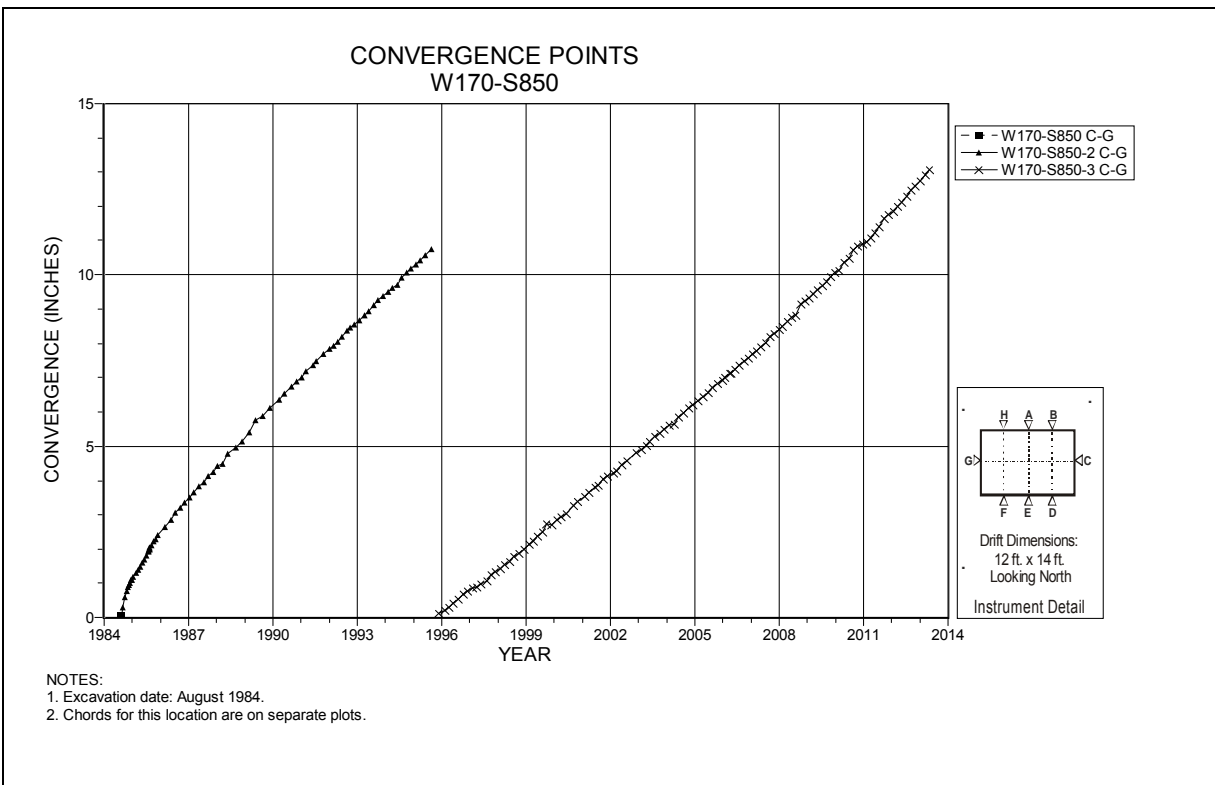

Figure 4-238 Convergence Point Array
W170 S850 – Rib to Rib

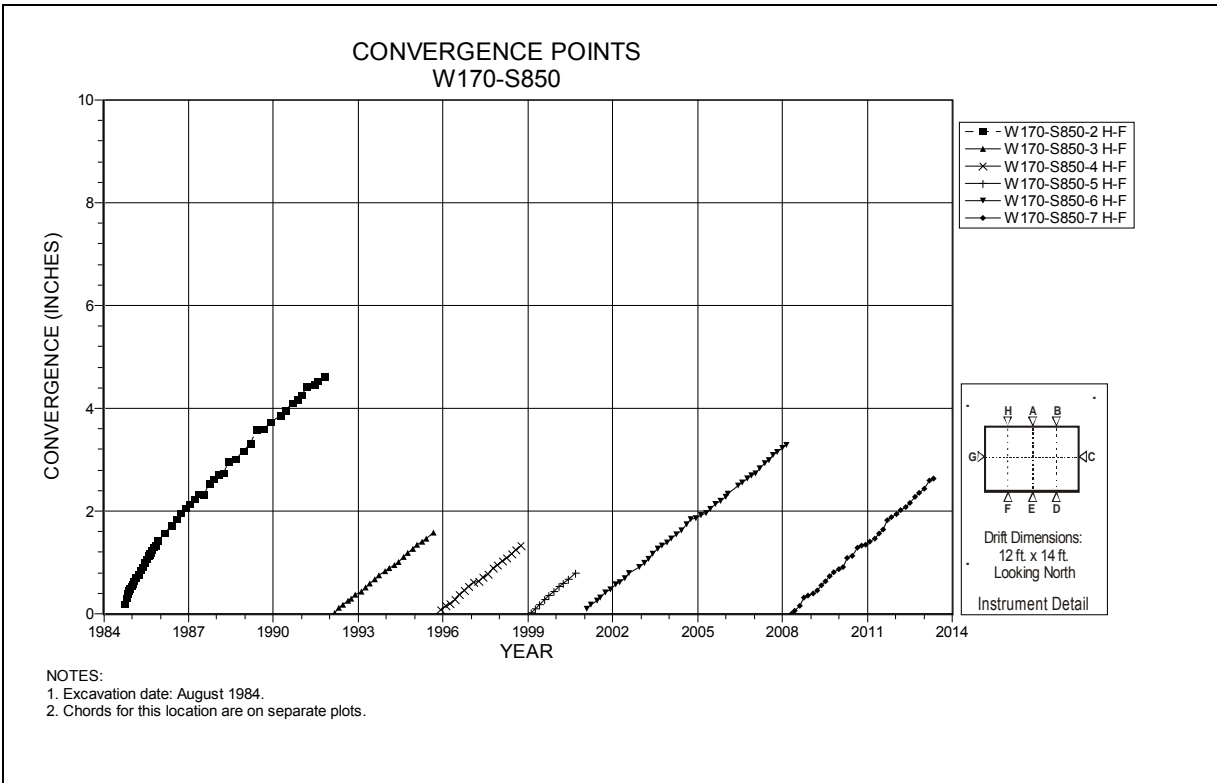

Figure 4-239 Convergence Point Array
W170 S850 – Roof to Floor – West Quarter Point

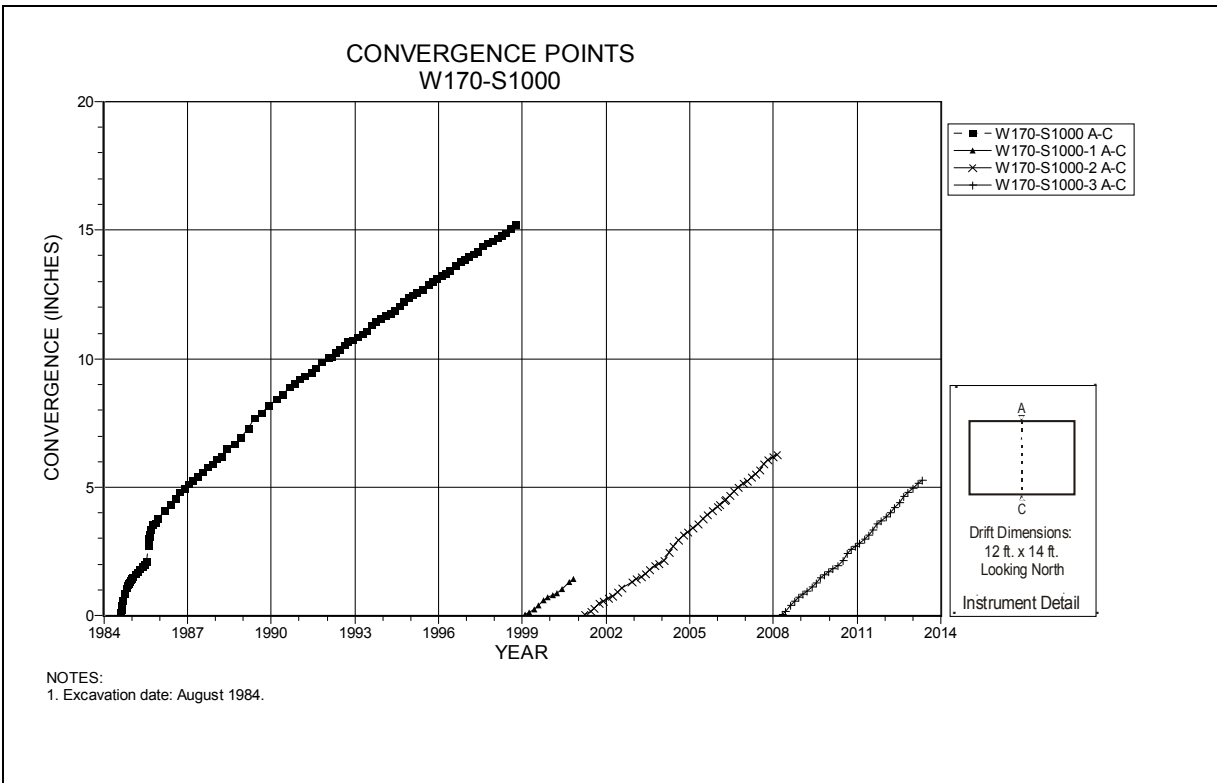

Figure 4-240 Convergence Point Array
W170 S1000 – Roof to Floor

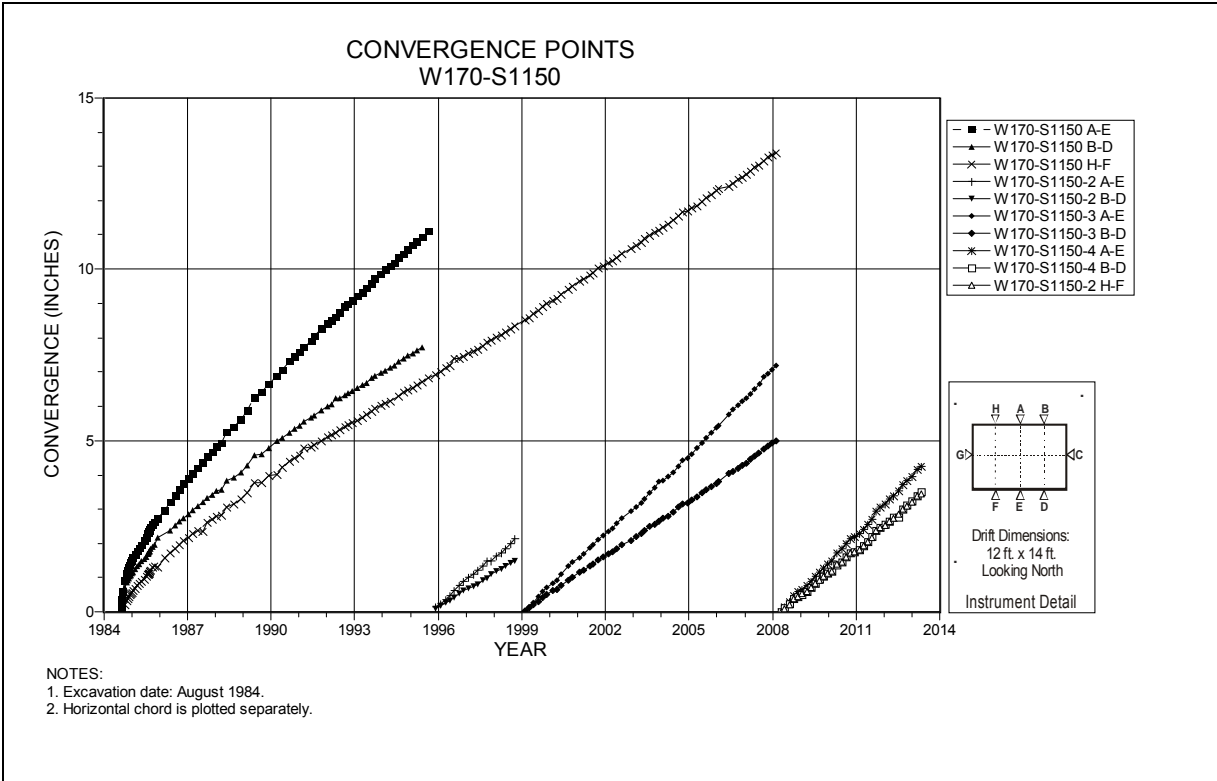

Figure 4-241 Convergence Point Array
W170 S1150 – Roof to Floor

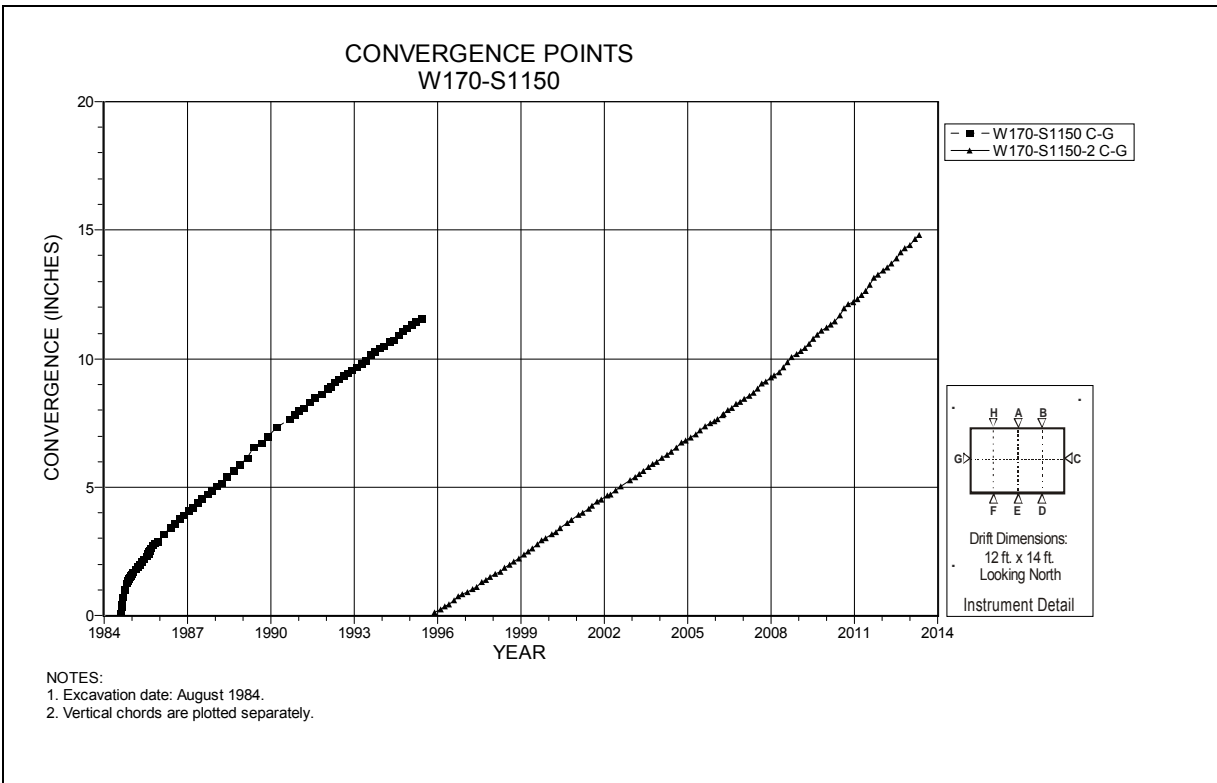

Figure 4-242 Convergence Point Array
W170 S1150 – Rib to Rib

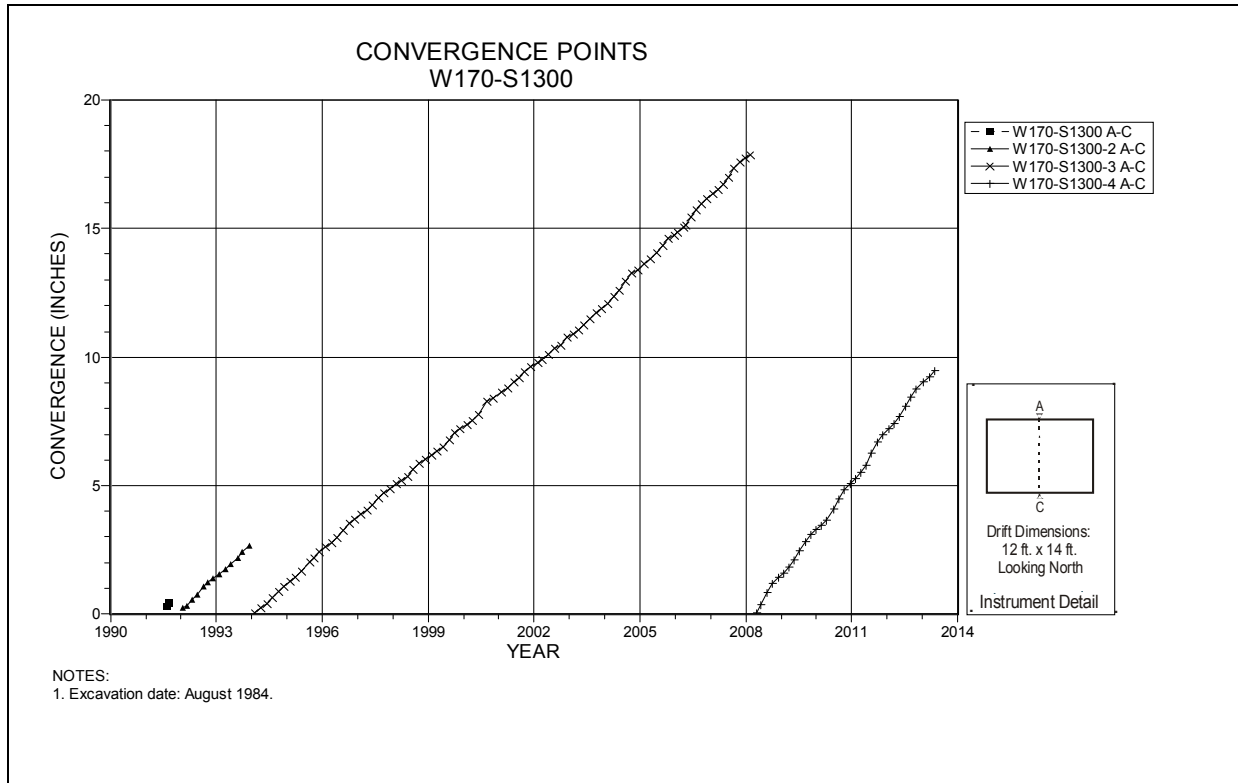

Figure 4-243 Convergence Point Array
W170 S1300 – Roof to Floor

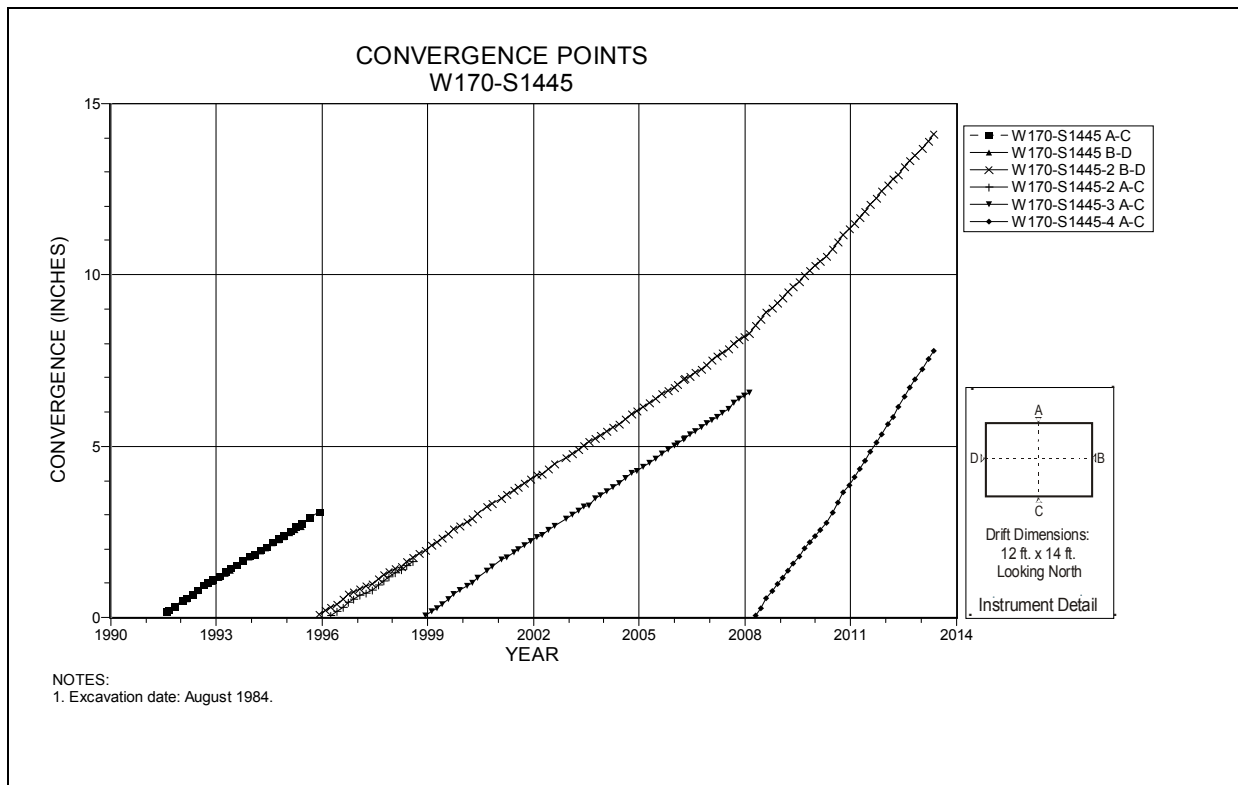

Figure 4-244 Convergence Point Array
W170 S1445 – All Chords

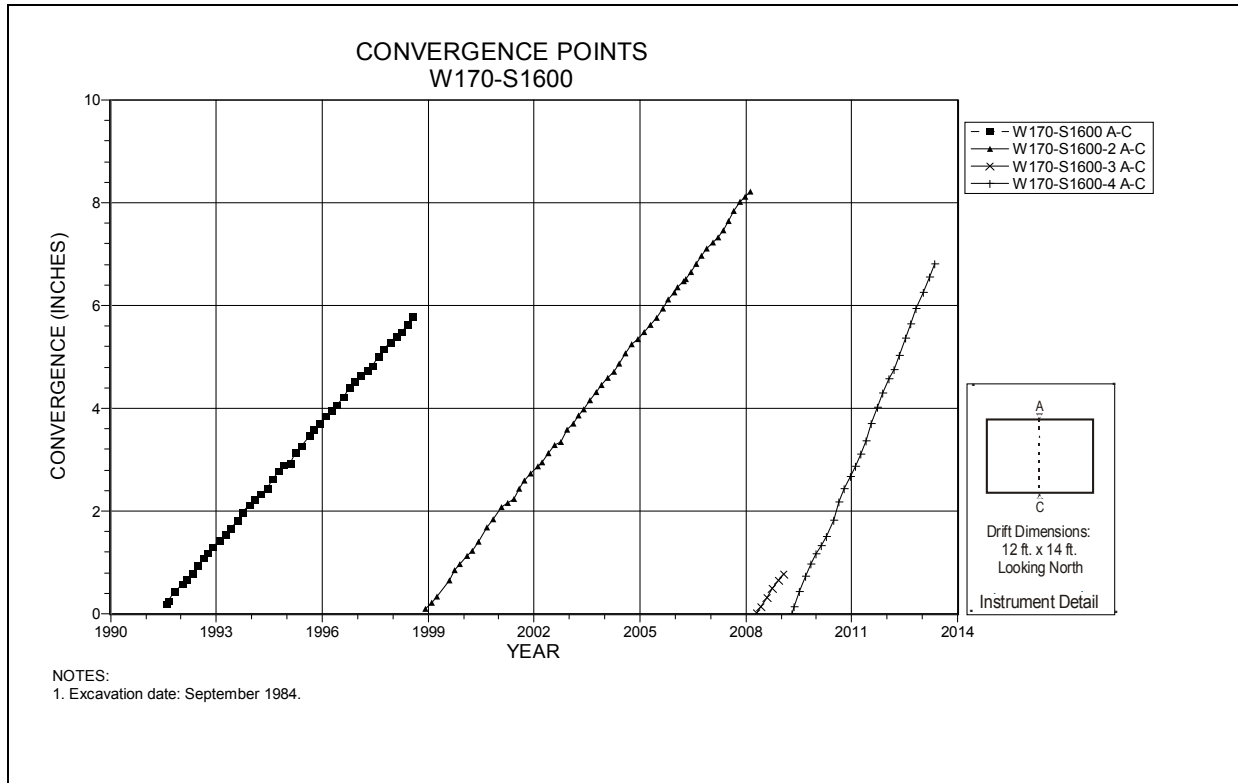

Figure 4-245 Convergence Point Array
W170 S1600 – Roof to Floor

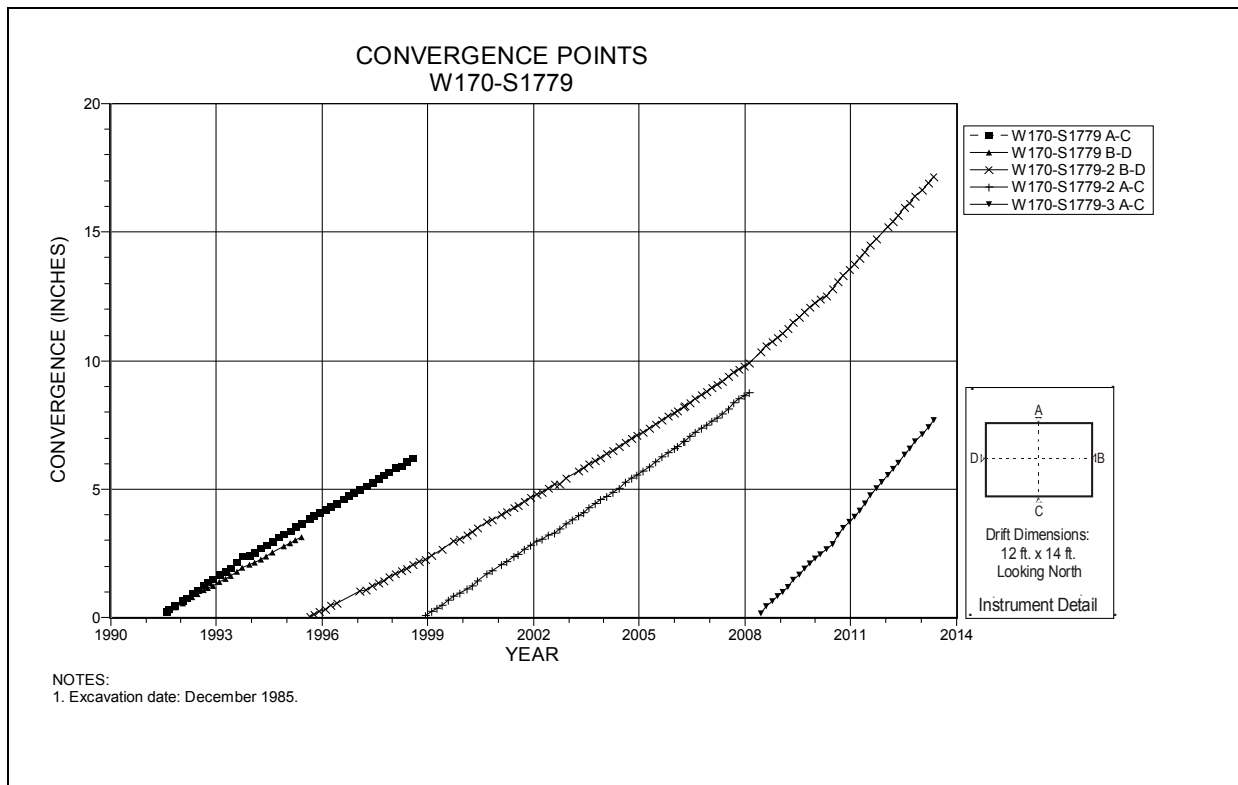

Figure 4-246 Convergence Point Array
W170 S1779 – All Chords

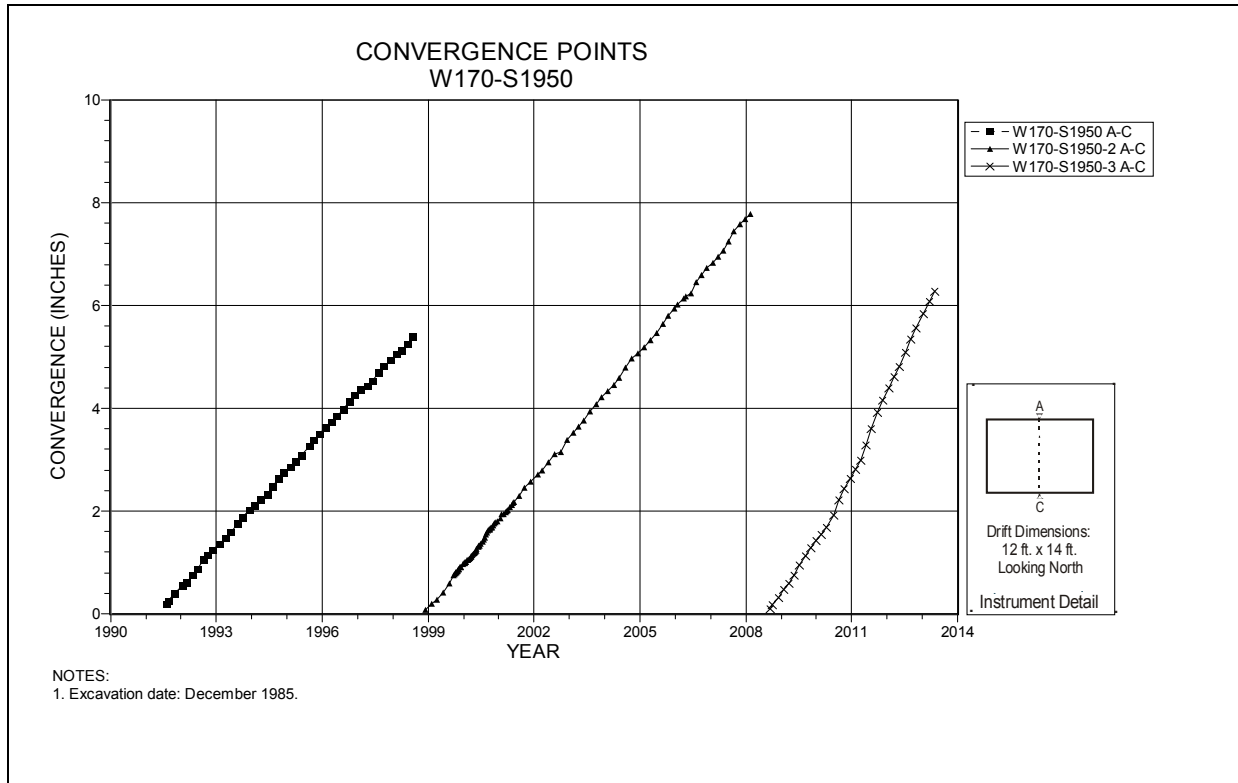

Figure 4-247 Convergence Point Array
W170 S1950 – Roof to Floor

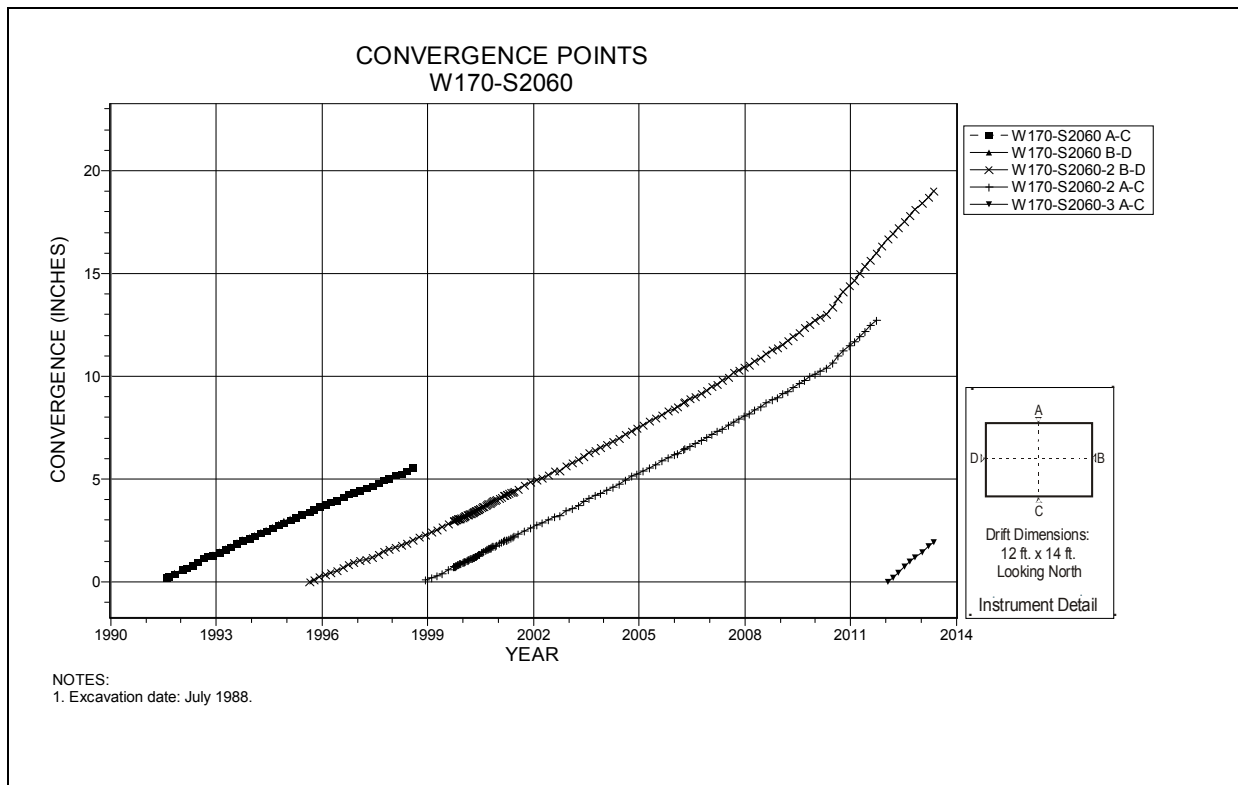

Figure 4-248 Convergence Point Array
W170 S2060 – All Chords

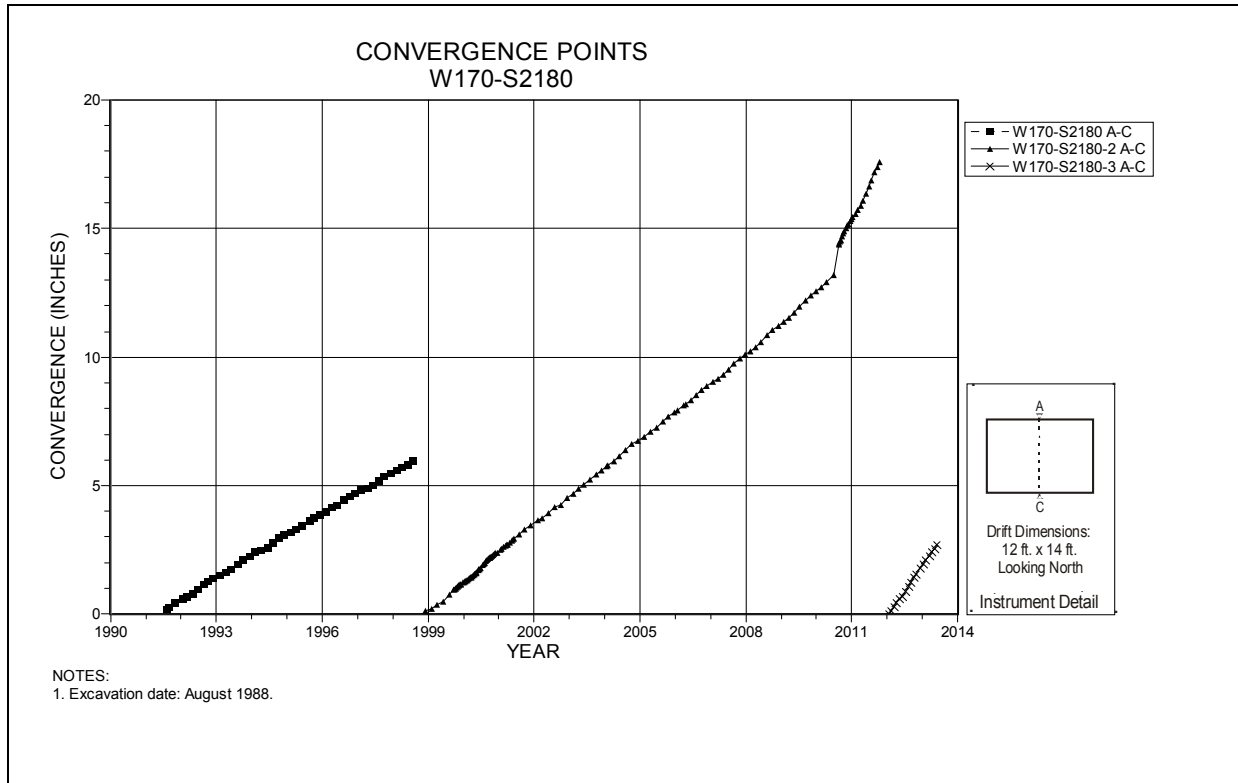

Figure 4-249 Convergence Point Array
W170 S2180 – Roof to Floor

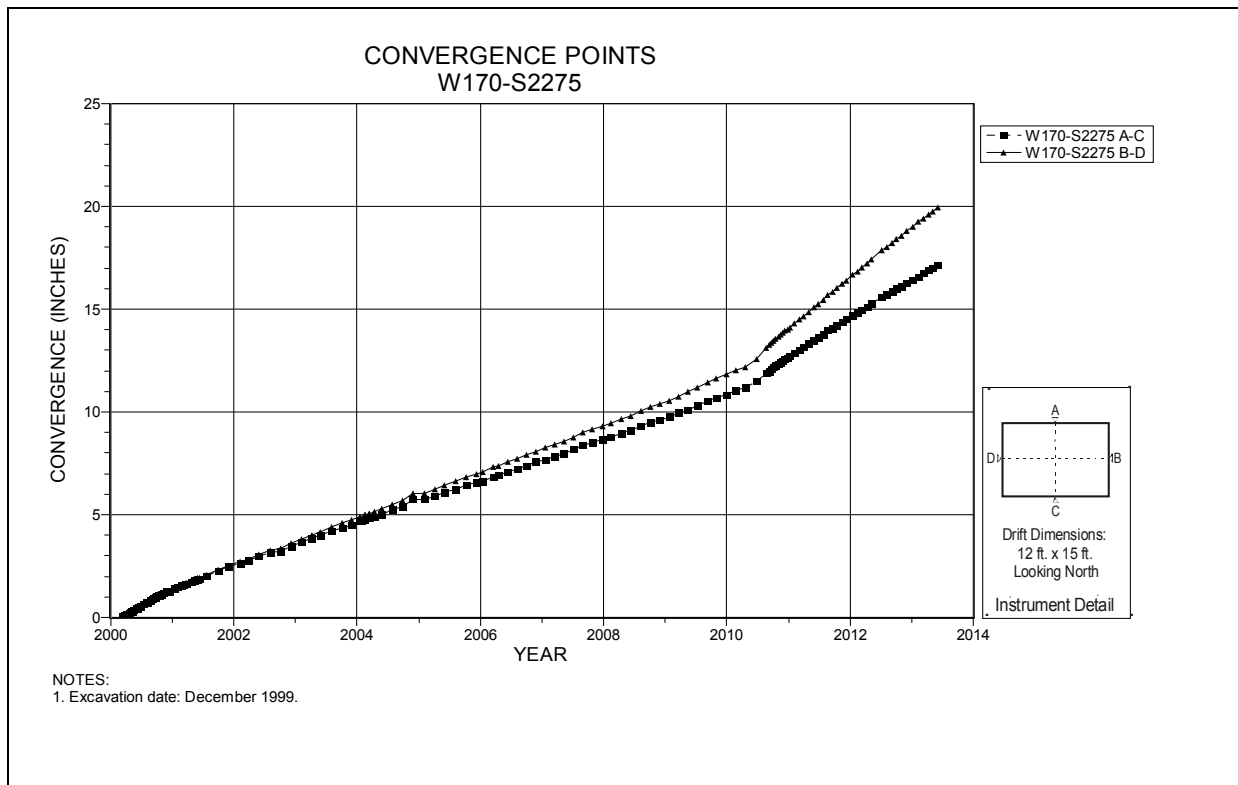

Figure 4-250 Convergence Point Array
W170 S2275 – All Chords

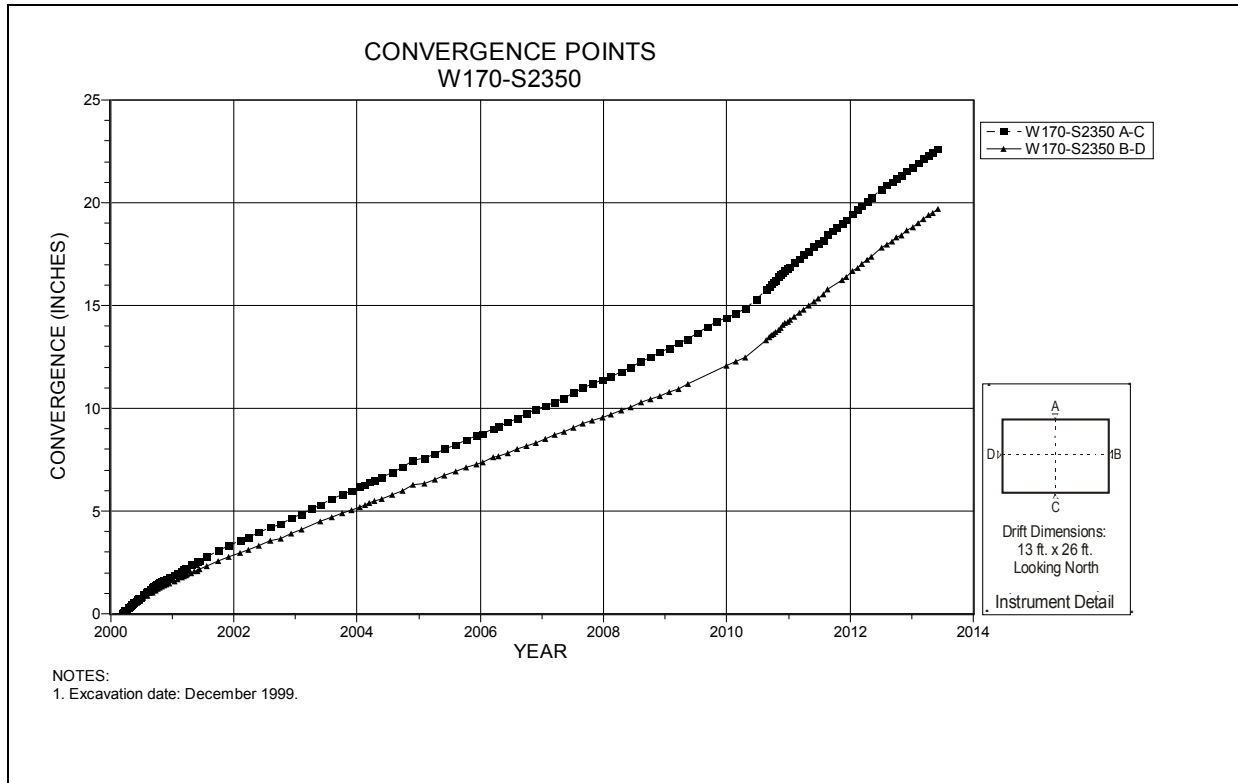

Figure 4-251 Convergence Point Array
W170 S2350 – All Chords

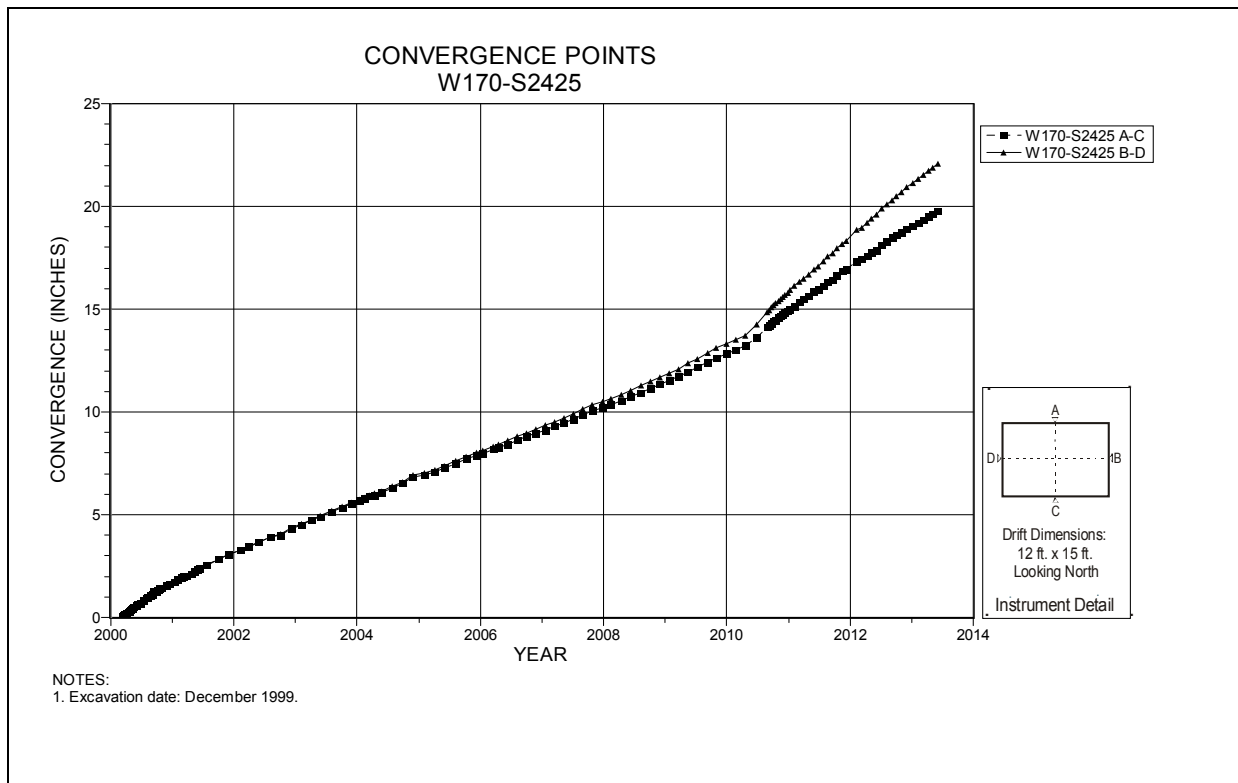

Figure 4-252 Convergence Point Array
W170 S2425 – All Chords

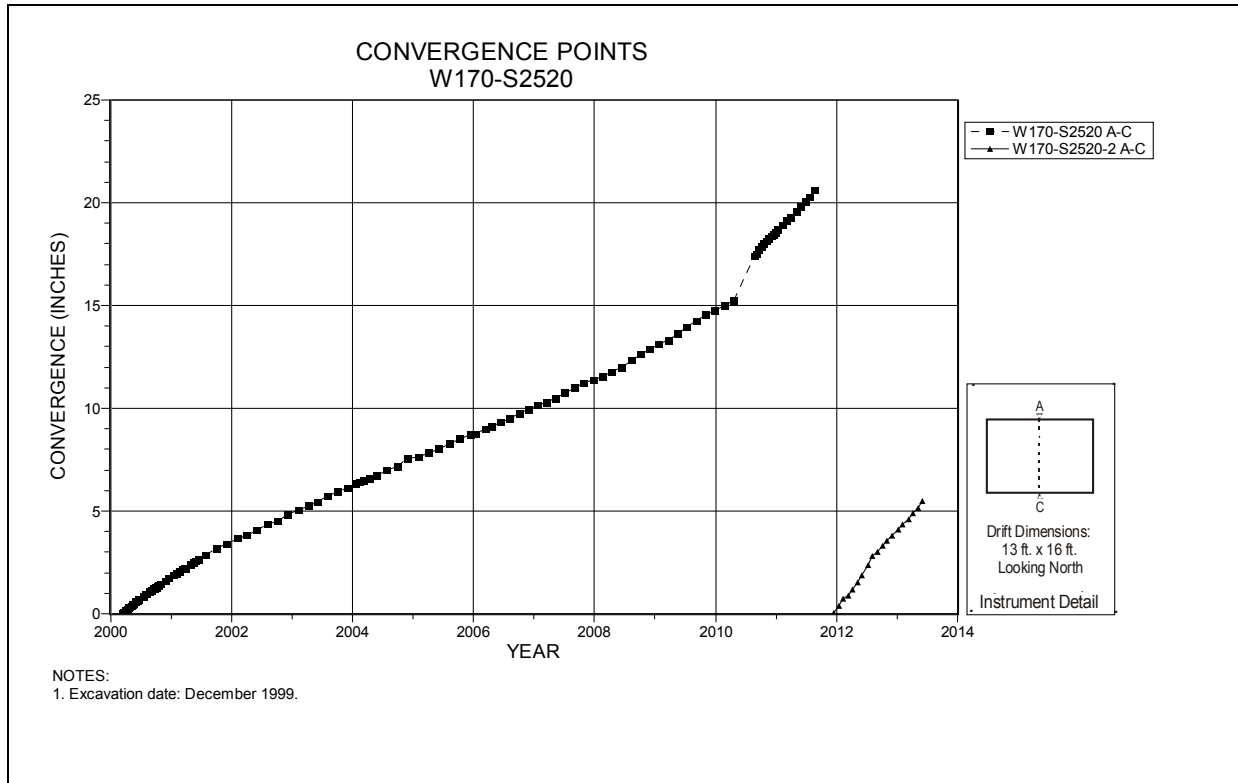

Figure 4-253 Convergence Point Array
W170 S2520 – Roof to Floor

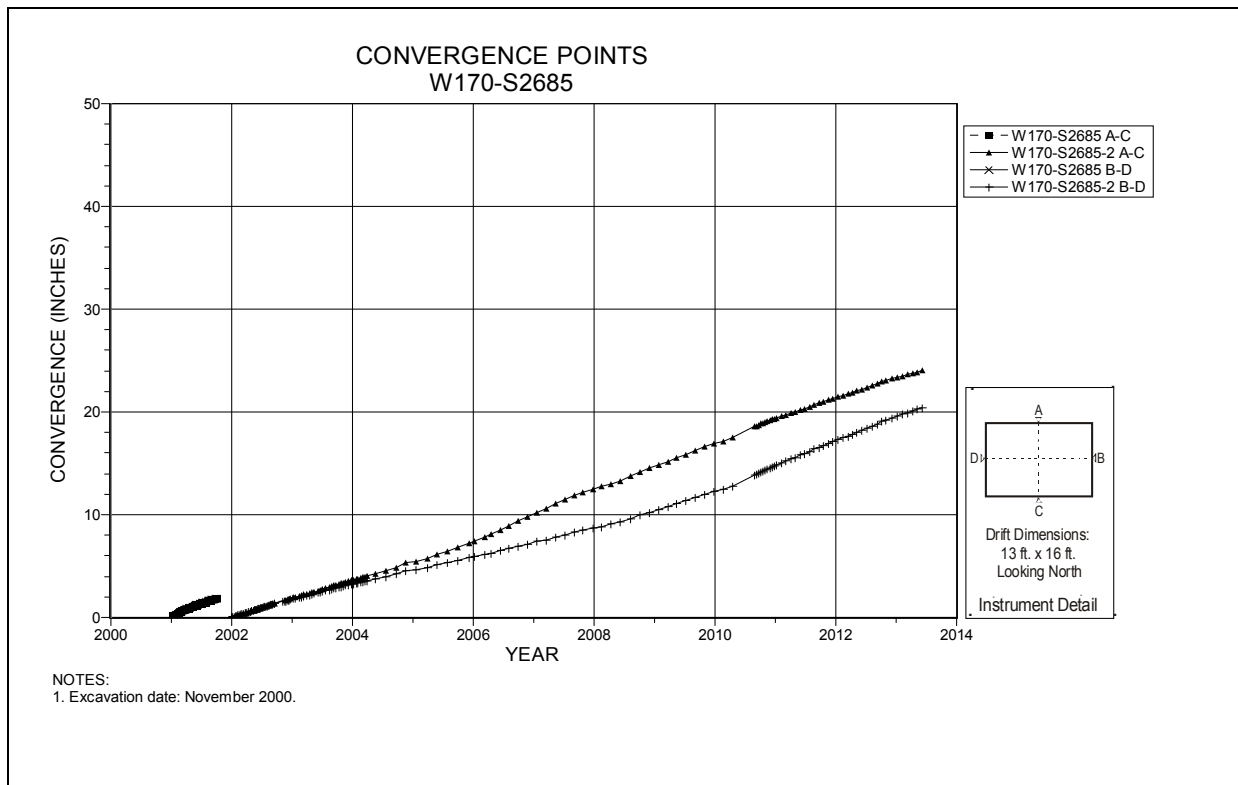

Figure 4-254 Convergence Point Array
W170 S2685 – All Chords

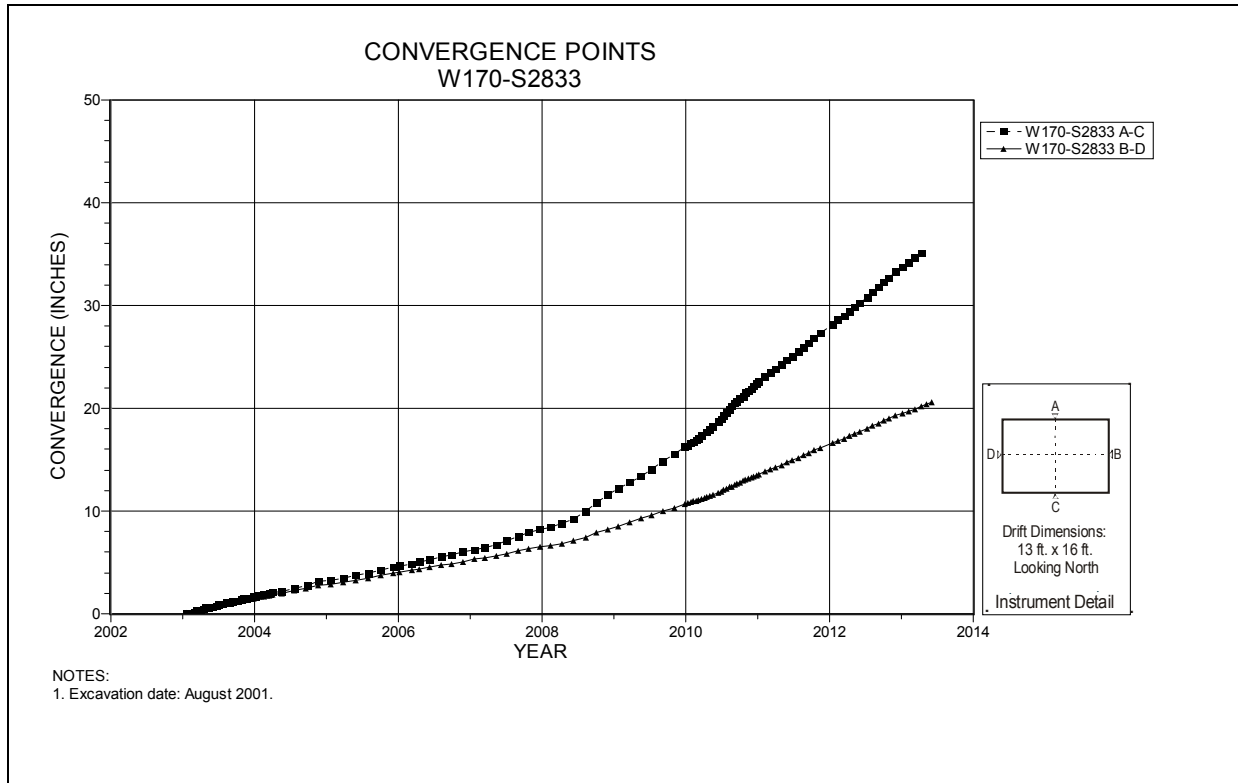

Figure 4-255 Convergence Point Array
W170 S2833 – All Chords

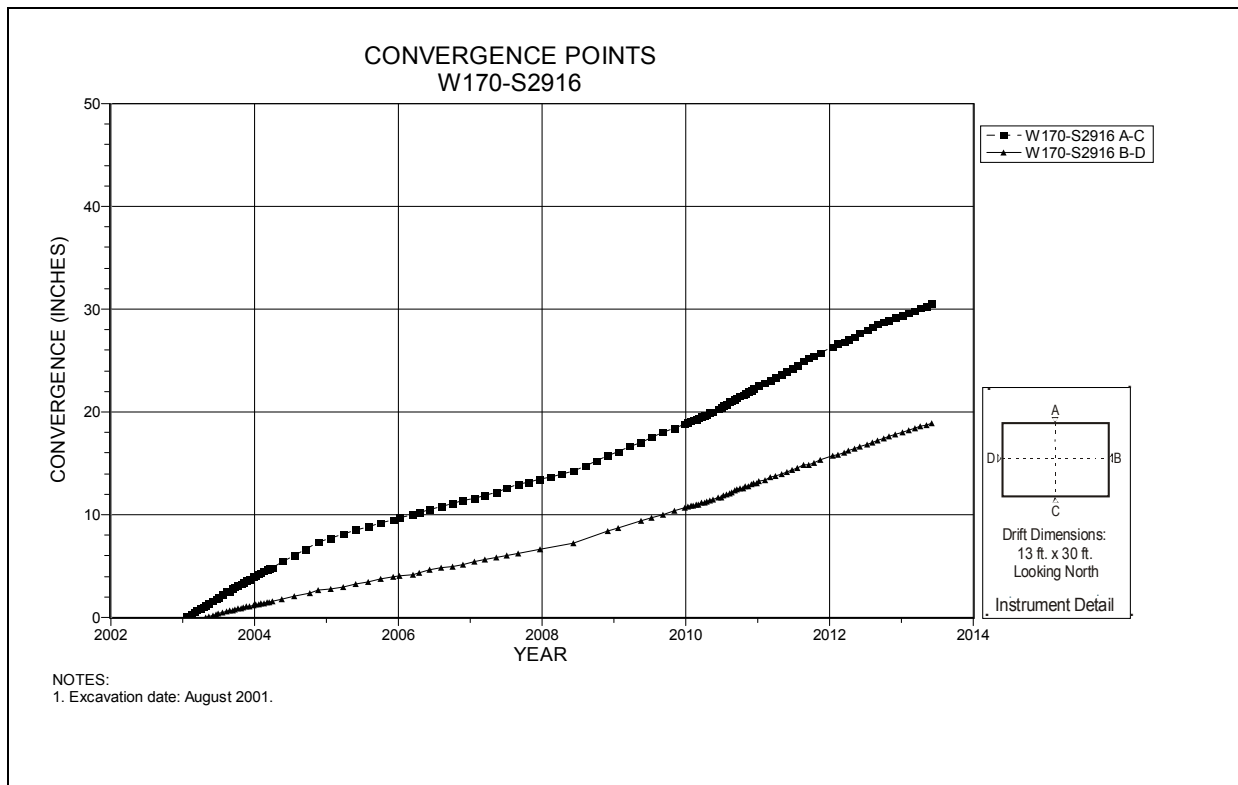

Figure 4-256 Convergence Point Array
W170 S2916 – All Chords

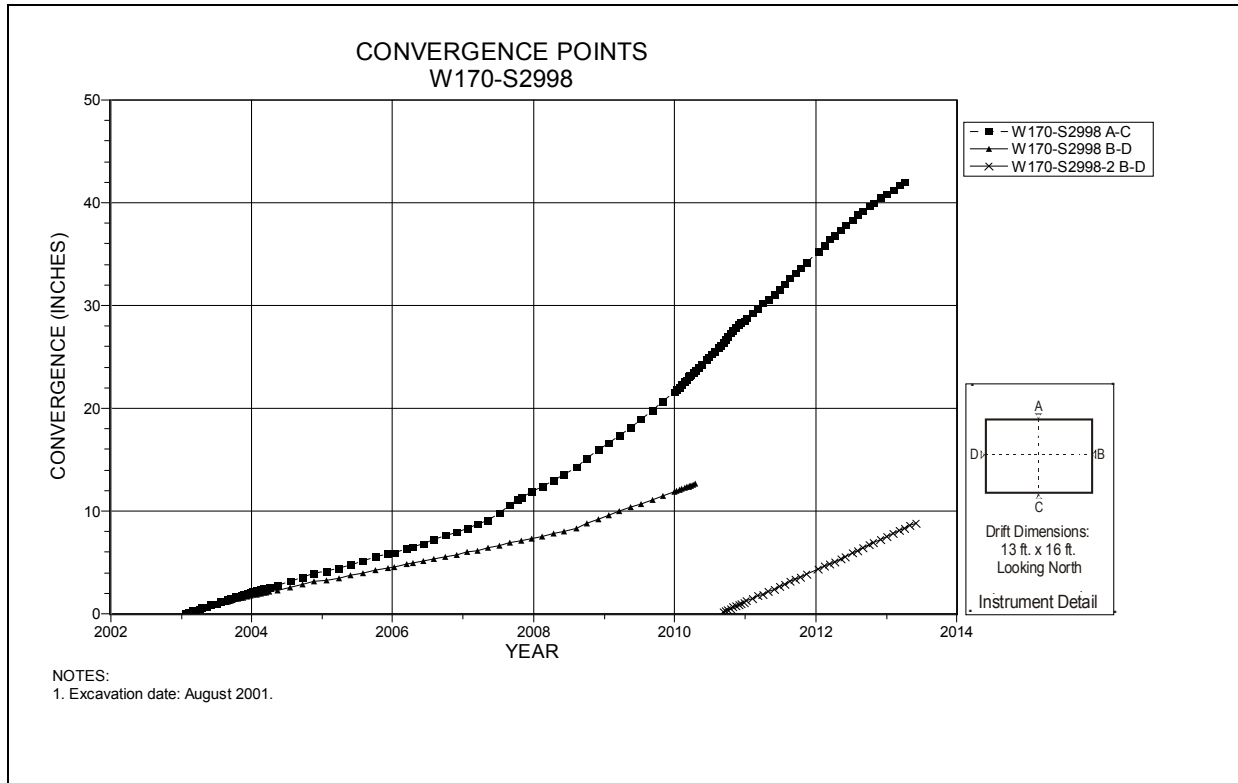

Figure 4-257 Convergence Point Array
W170 S2998 – All Chords

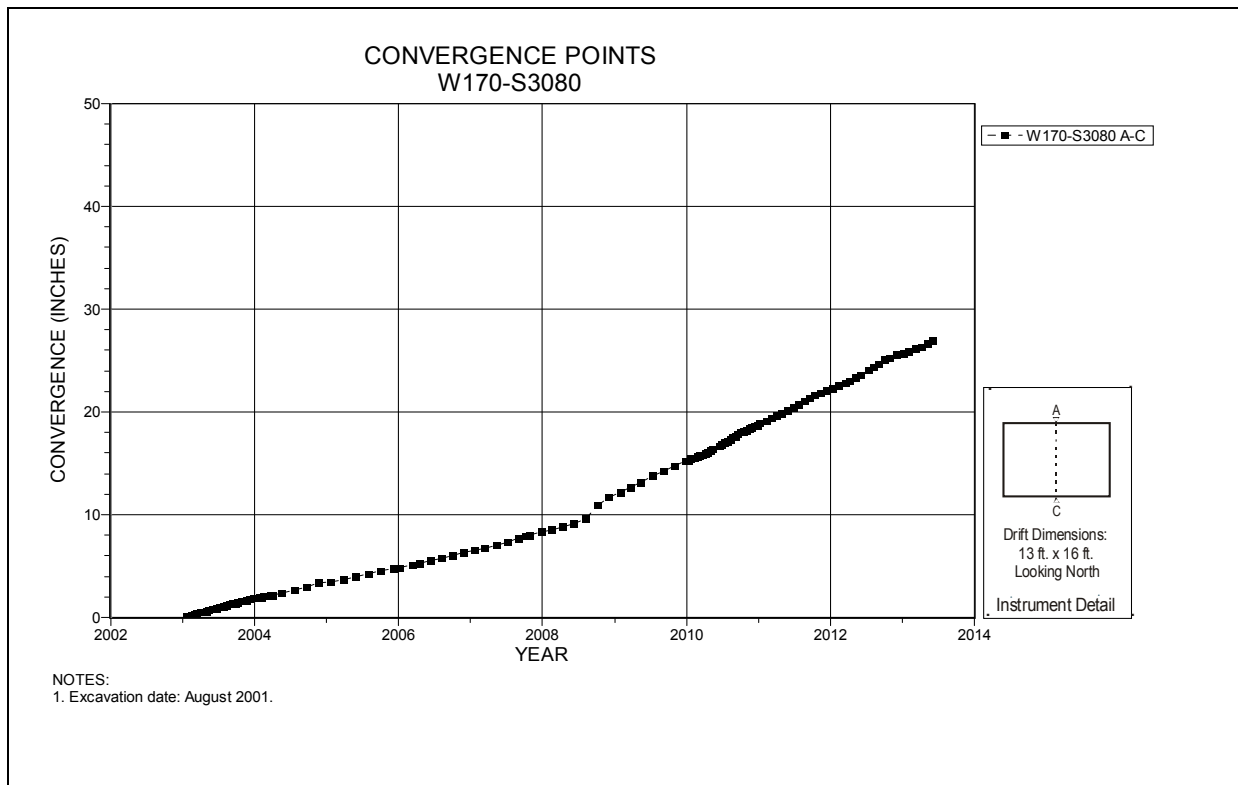

Figure 4-258 Convergence Point Array
W170 S3080 – Roof to Floor

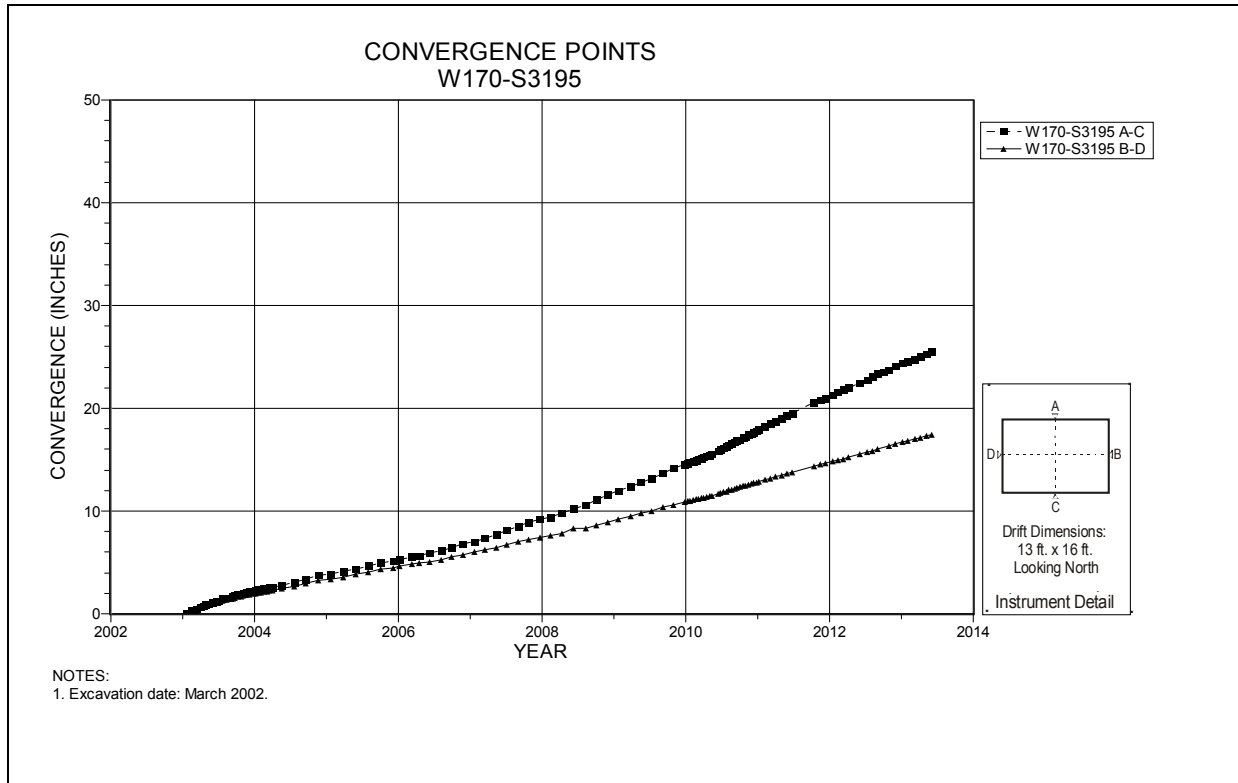

Figure 4-259 Convergence Point Array
W170 S3195 – All Chords

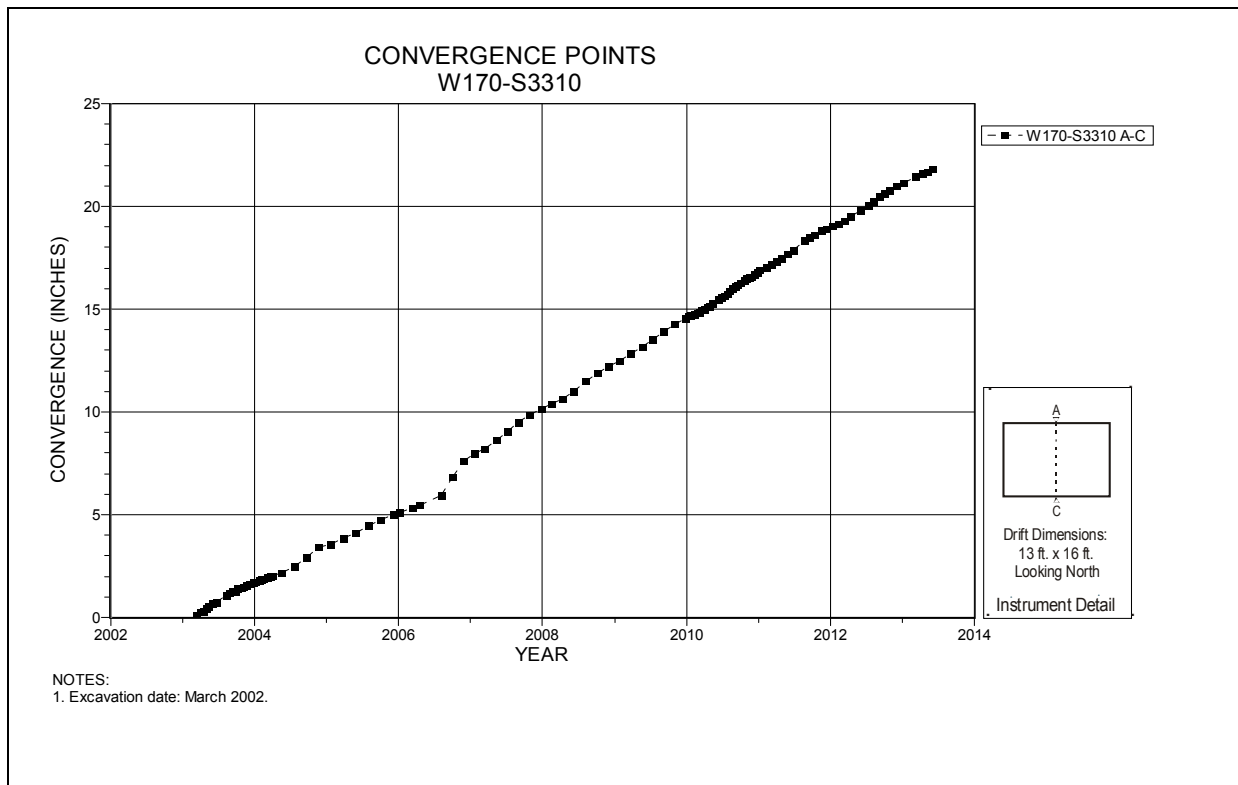

Figure 4-260 Convergence Point Array
W170 S3310 – Roof to Floor

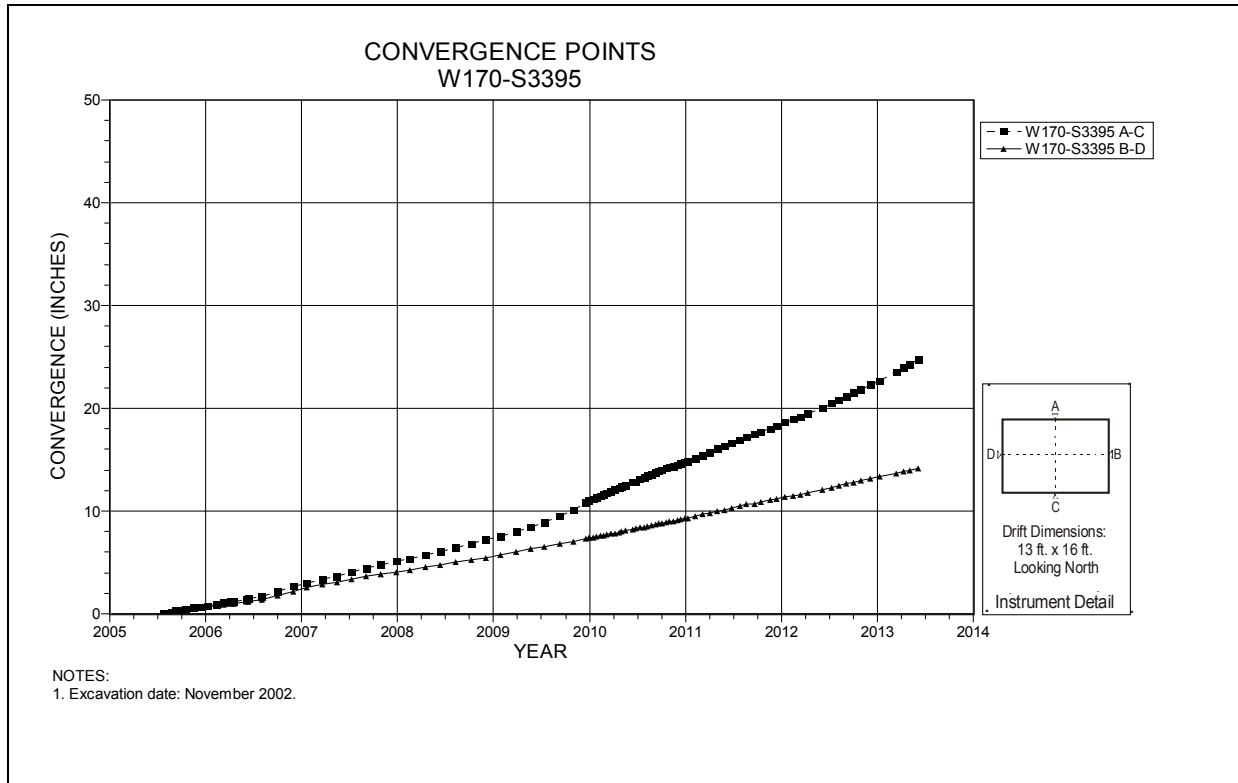

Figure 4-261 Convergence Point Array
W170 S3395 – All Chords

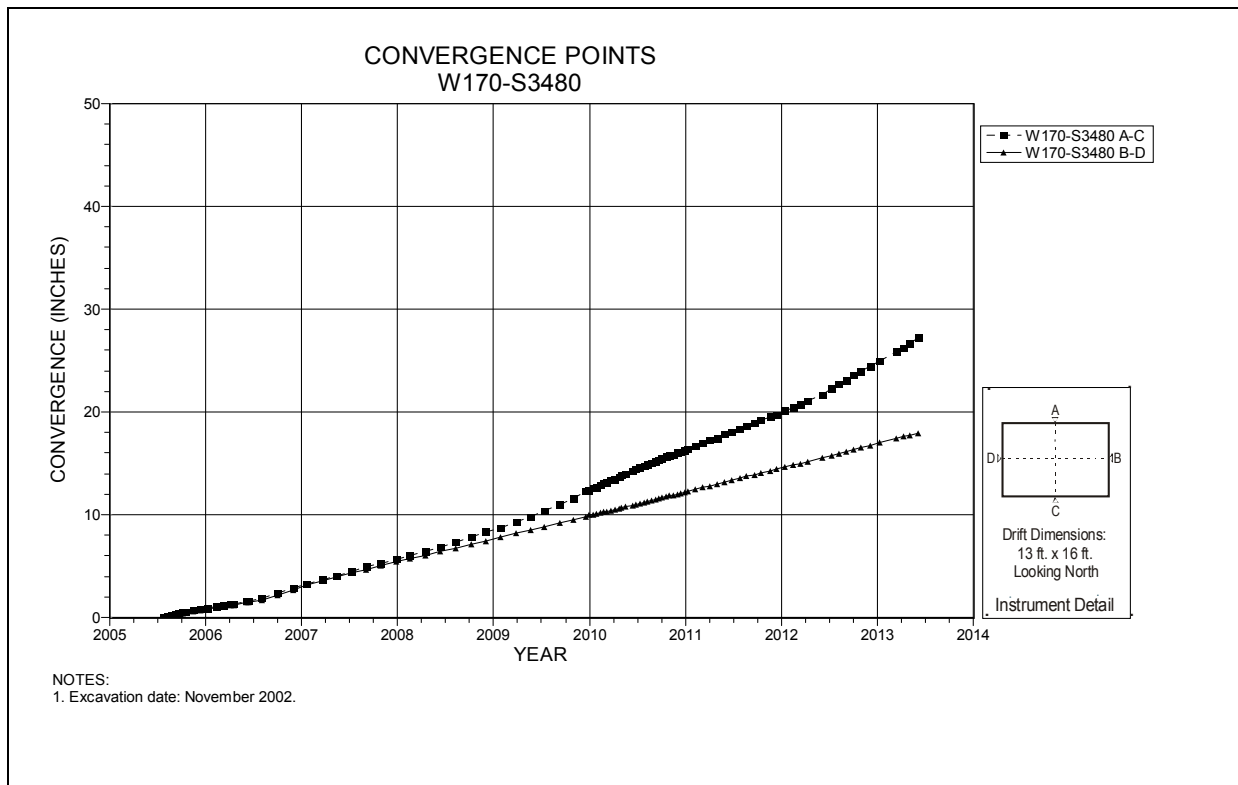

Figure 4-262 Convergence Point Array
W170 S3480 – All Chords

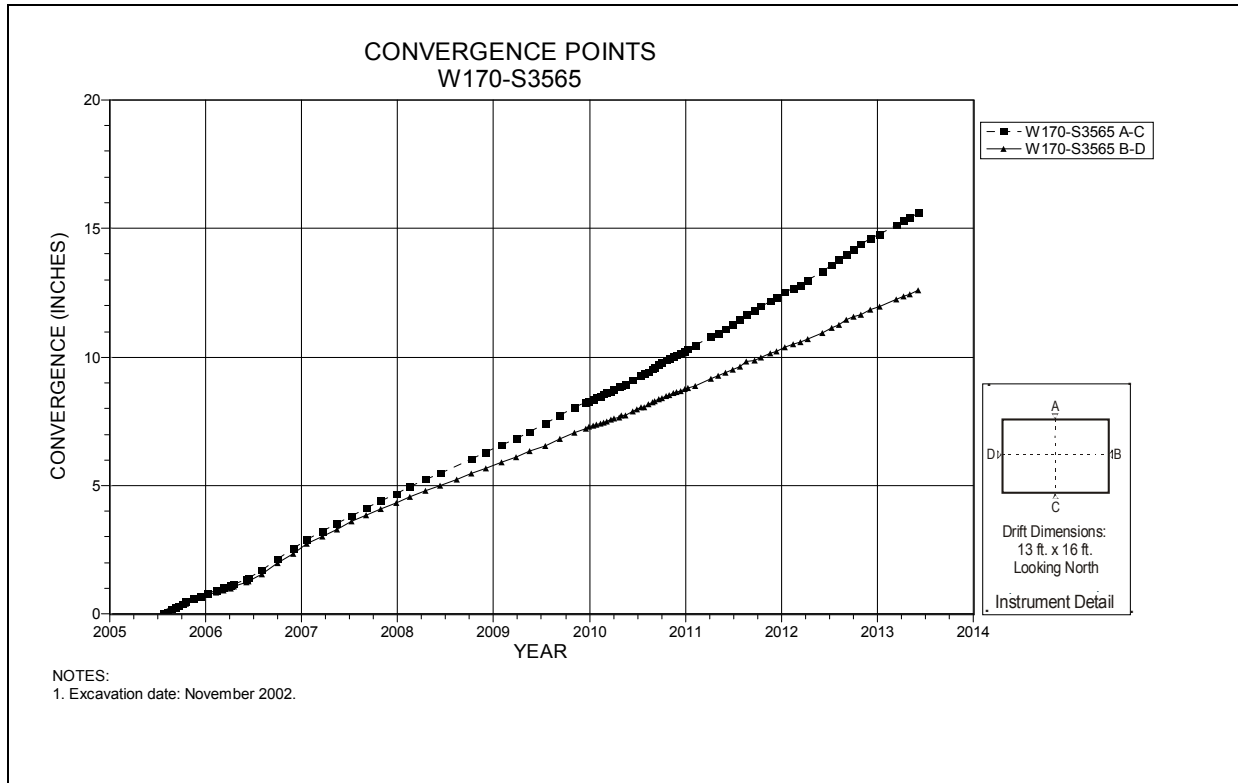

Figure 4-263 Convergence Point Array
W170 S3565 – All Chords

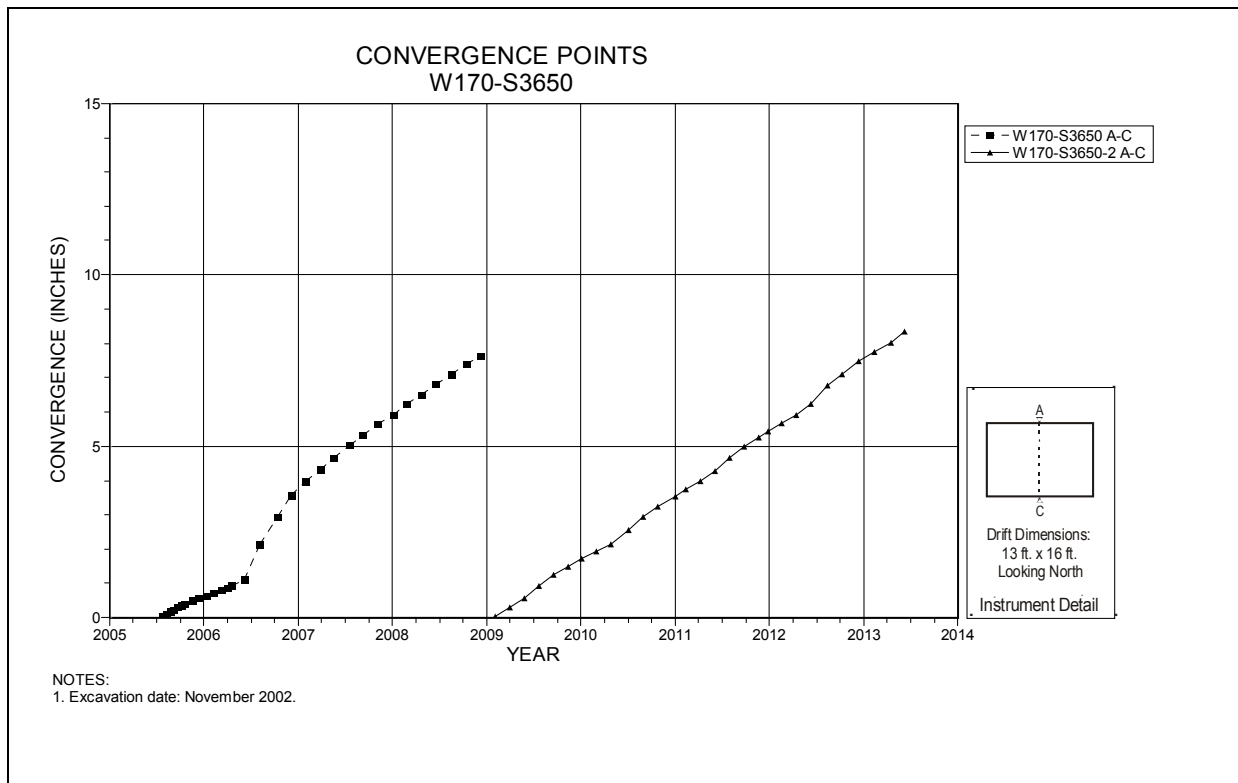

Figure 4-264 Convergence Point Array
W170 S3650 – Roof to Floor

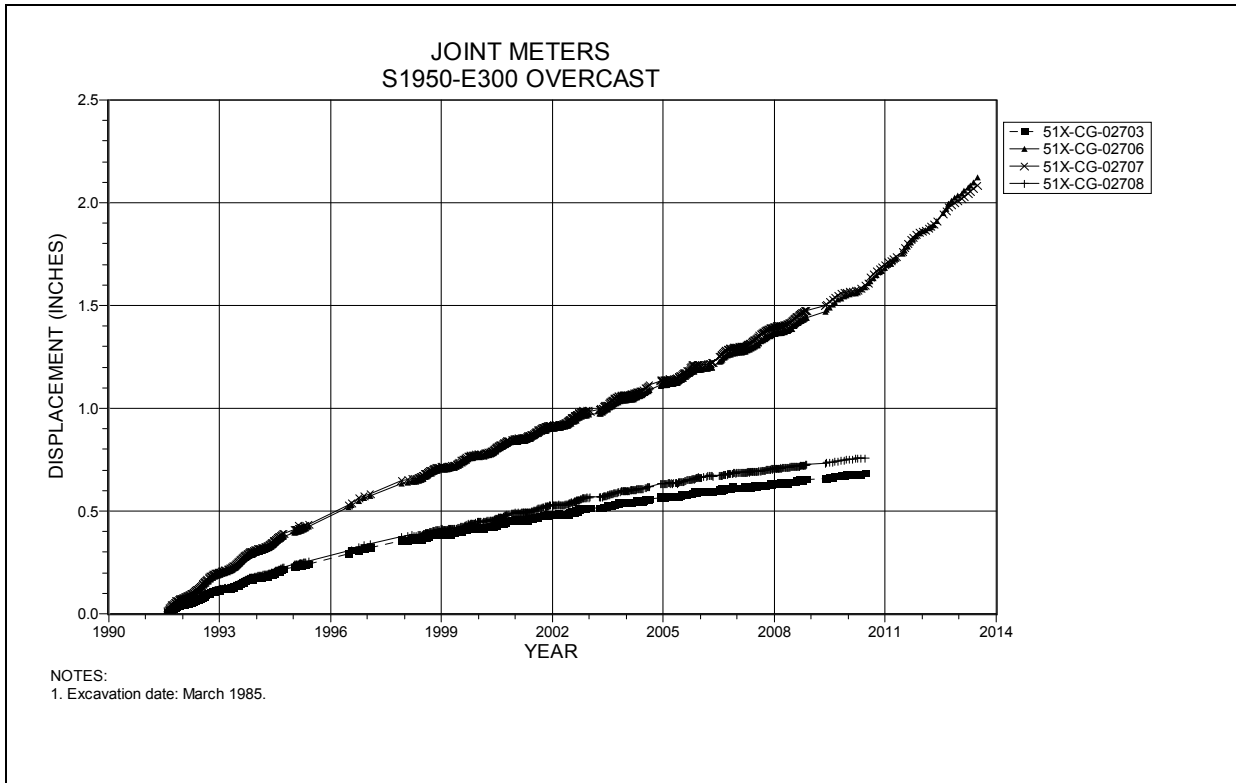

Figure 4-265 Joint Meters
S1950 E300 Overcast

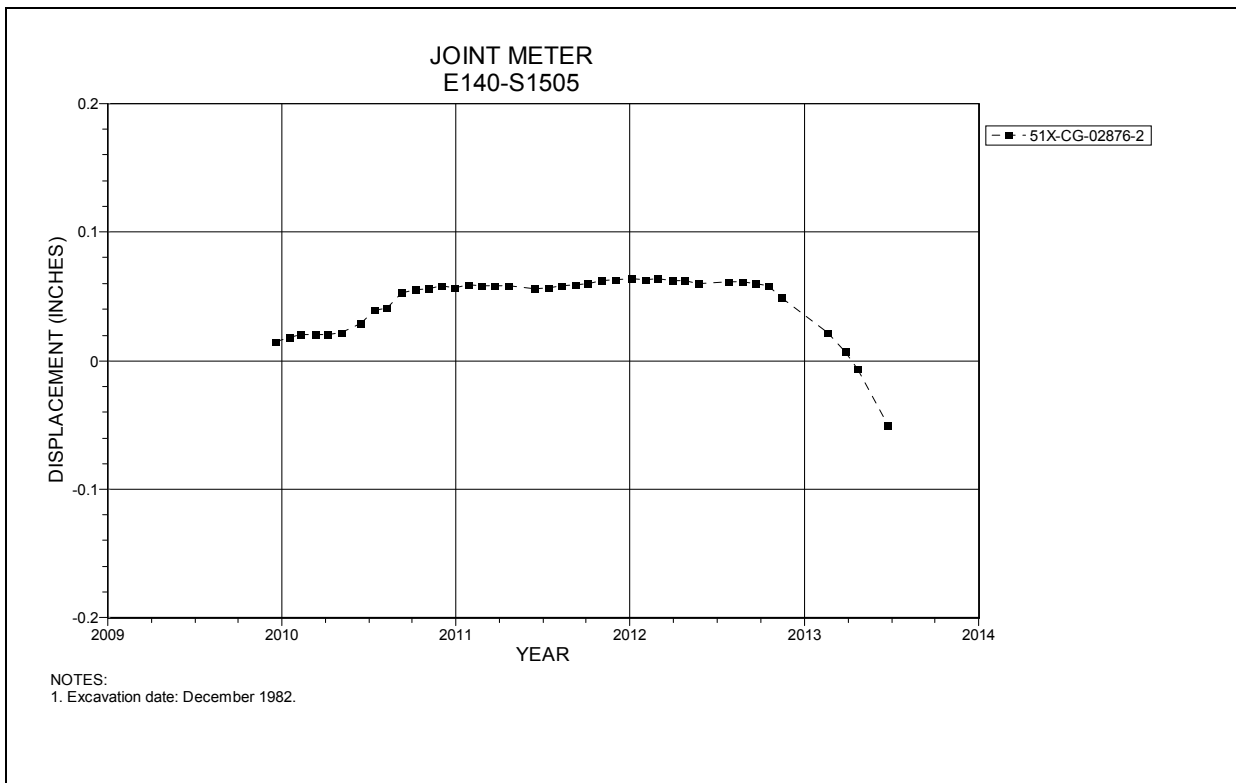

Figure 4-266 Joint Meter
E140 S1505

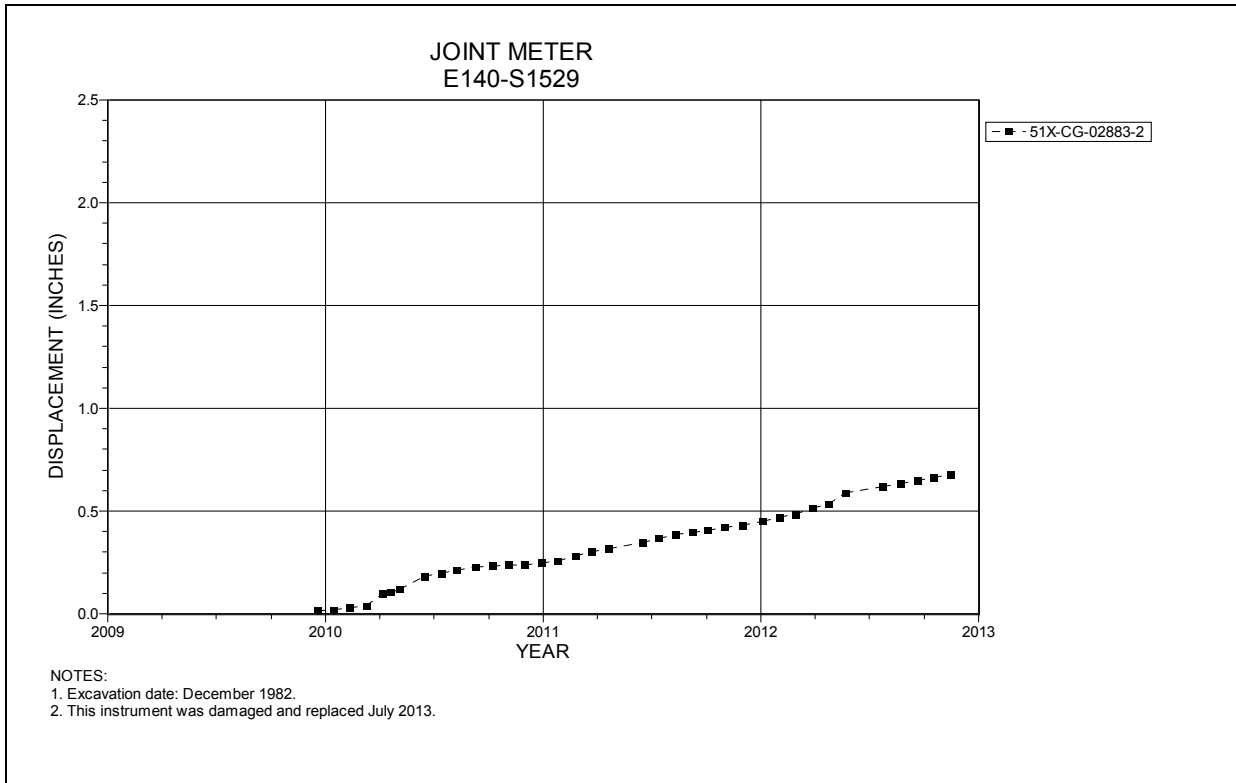

Figure 4-267 Joint Meter
E140 S1529

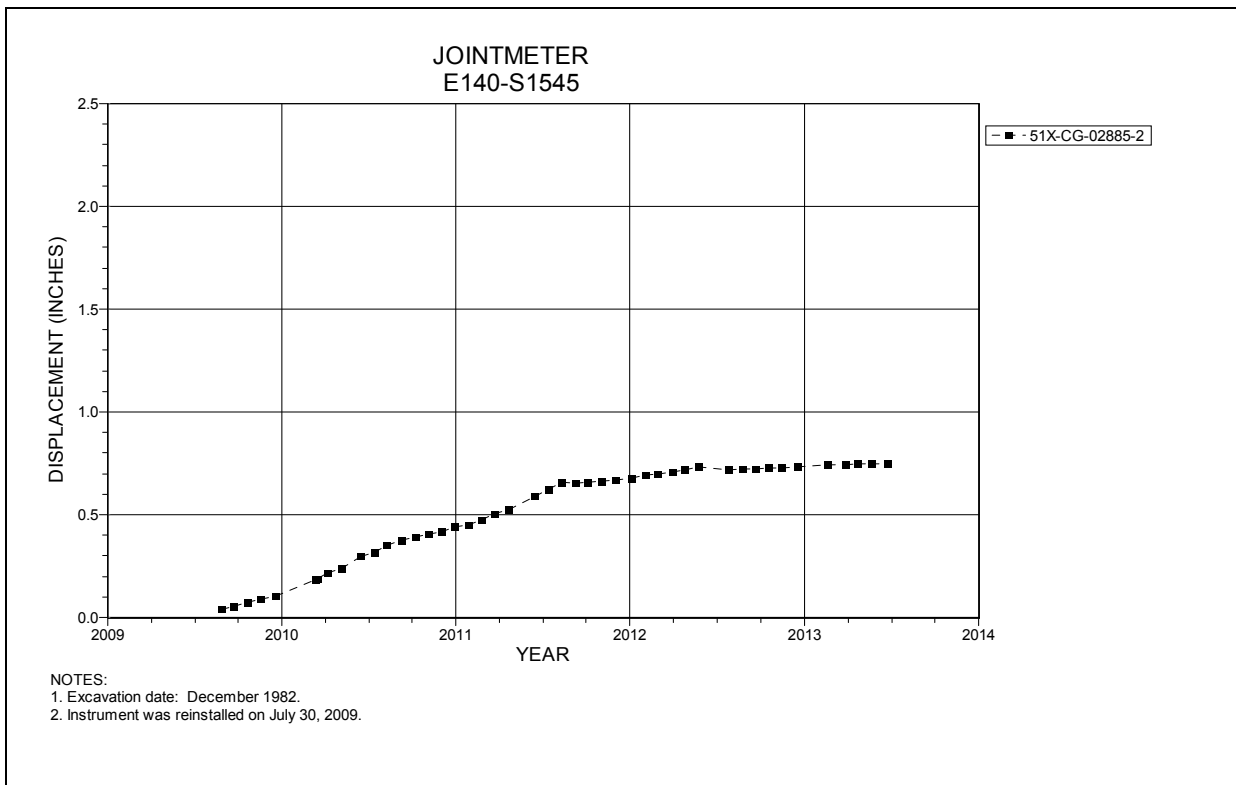

Figure 4-268 Joint Meter
E140 S1545

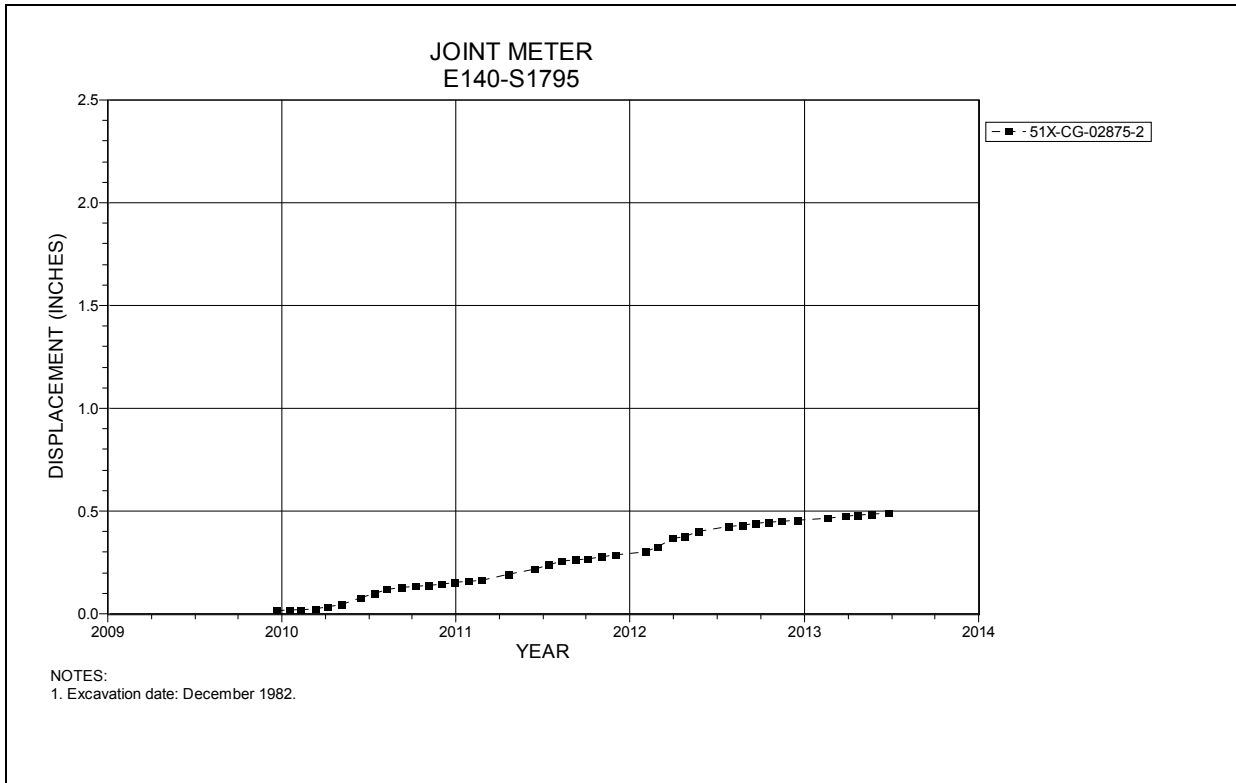

Figure 4-269 Joint Meter
E140 S1795

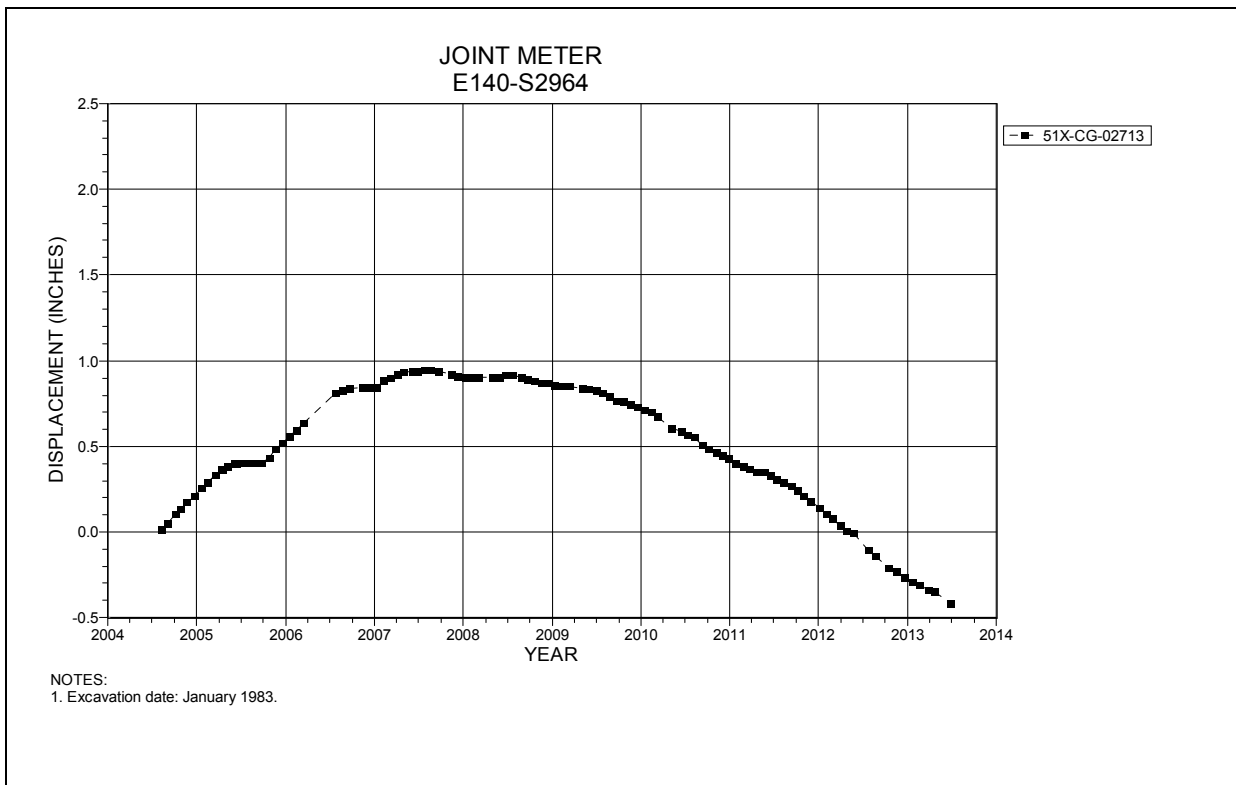

Figure 4-270 Joint Meter
E140 S2964

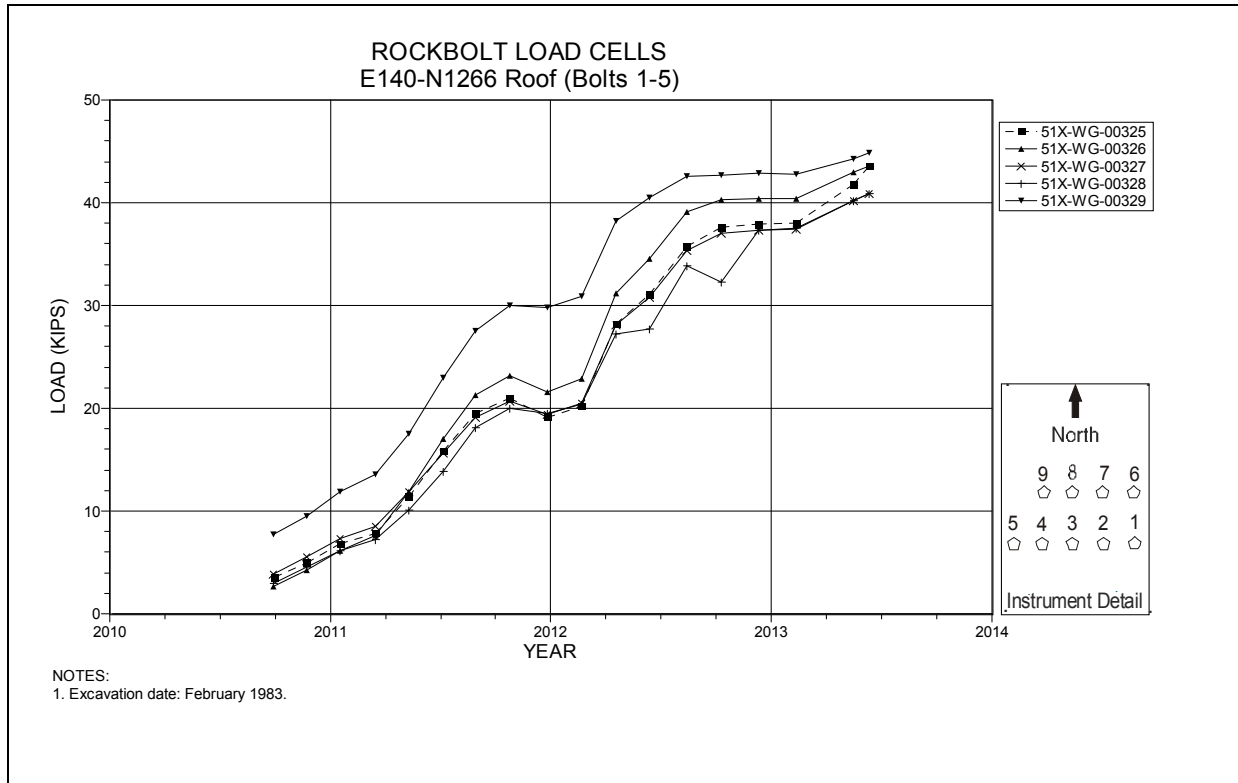

Figure 4-271 Rock Bolt Load Cells, Bolts 1-5
E140 N1266

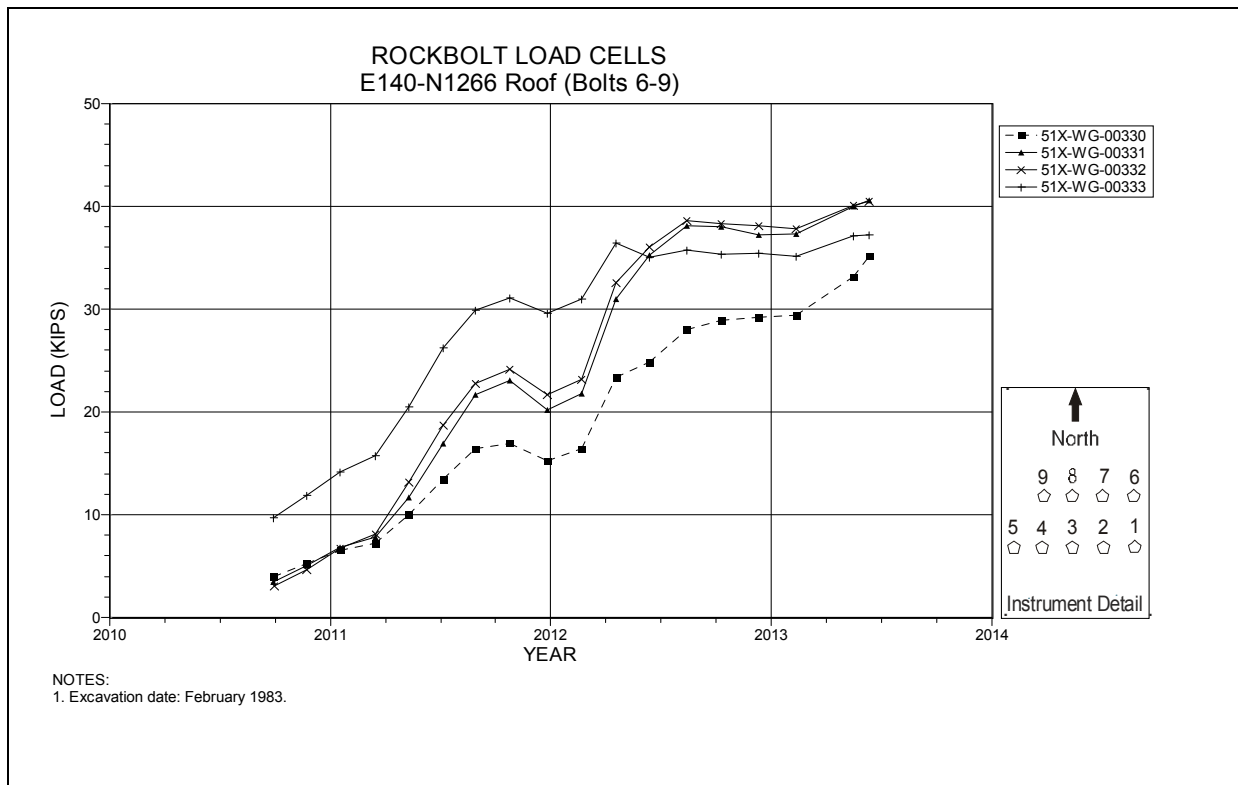

Figure 4-272 Rock Bolt Load Cells, Bolts 6-9
E140 N1266

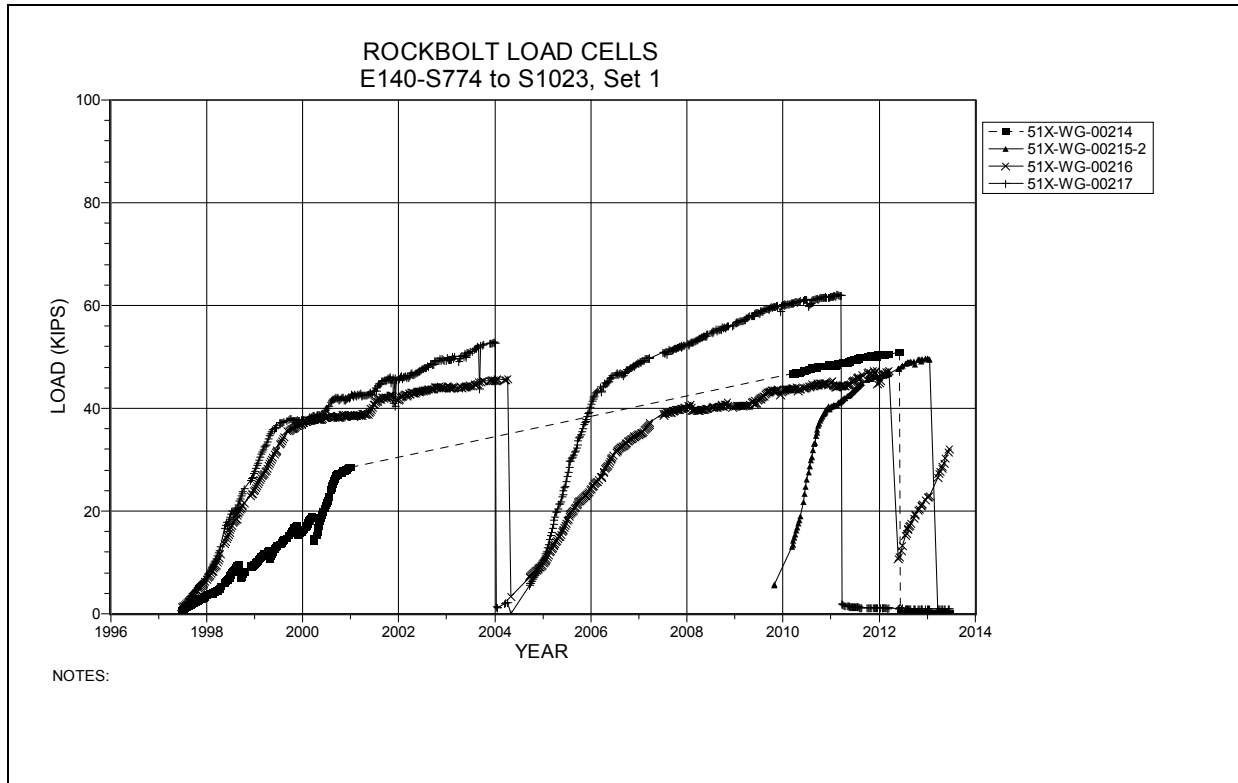

Figure 4-273 Rock Bolt Load Cells
E140 S774 – S1023

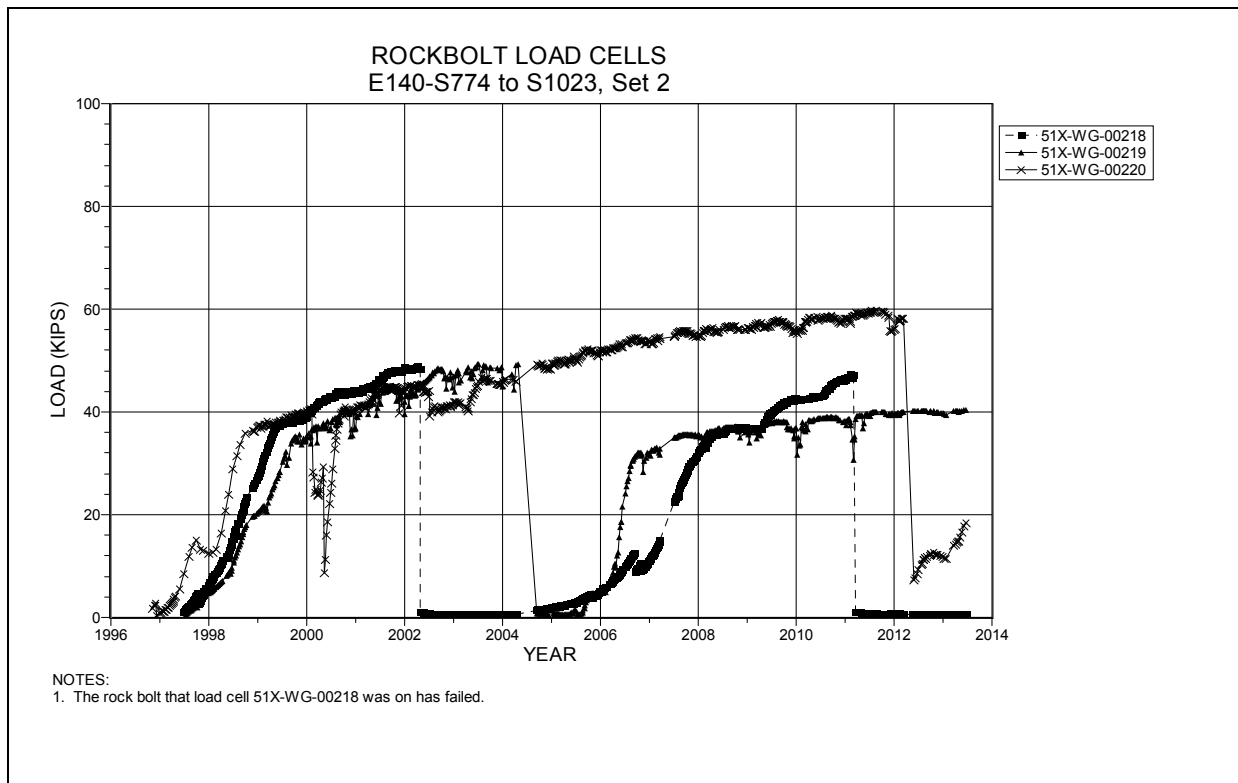

Figure 4-274 Rock Bolt Load Cells
E140 S910

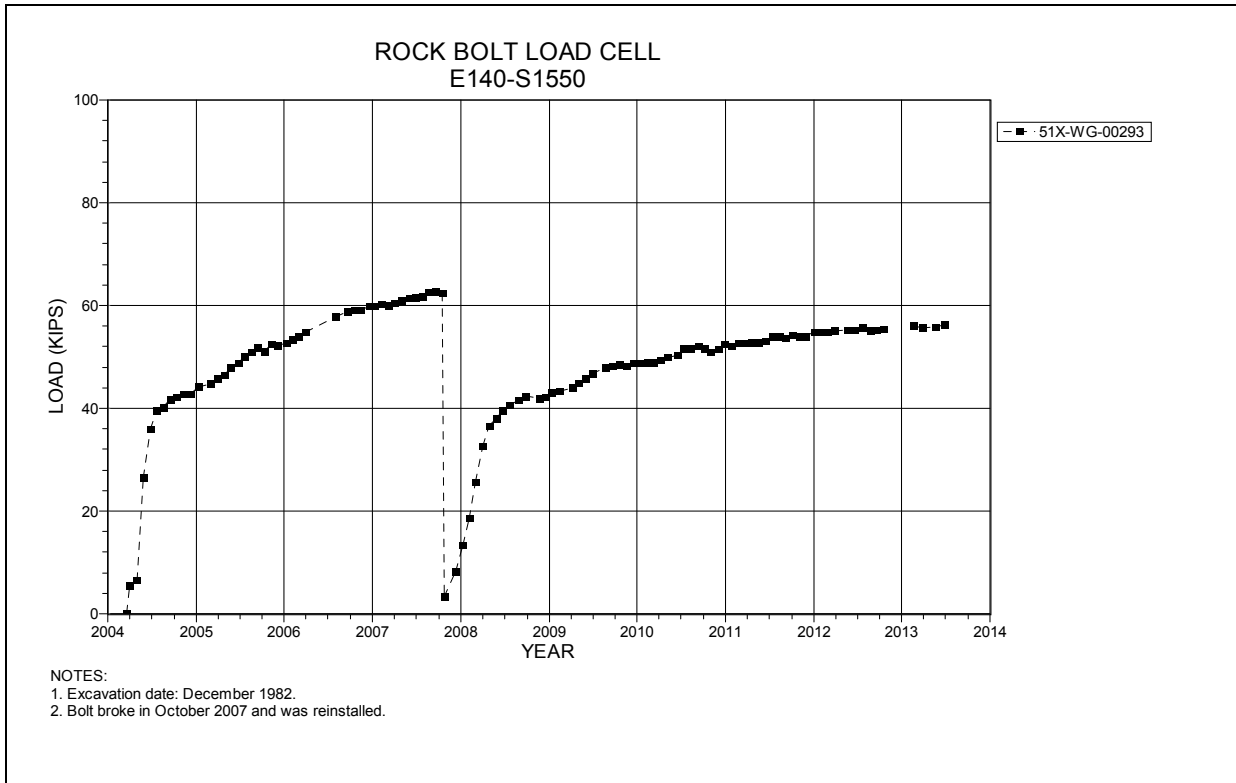

Figure 4-275 Rock Bolt Load Cell
E140 S1550

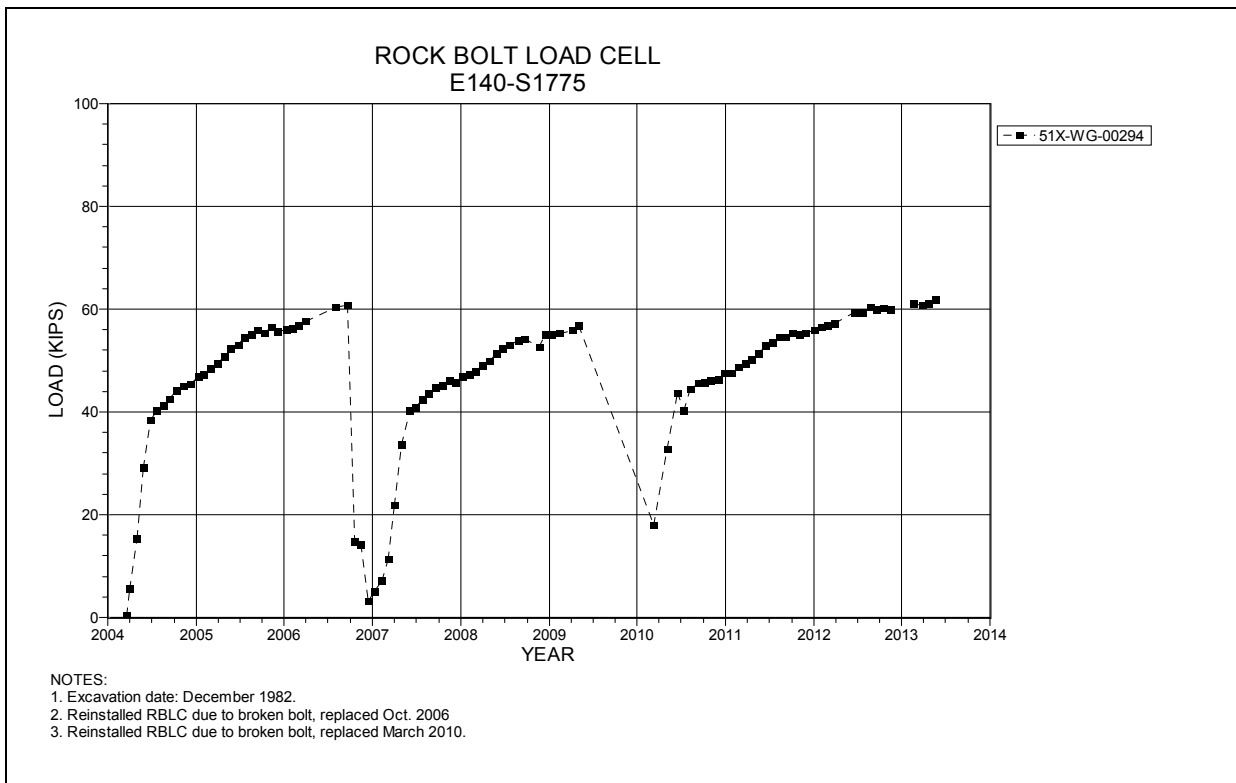

Figure 4-276 Rock Bolt Load Cell
E140 S1775

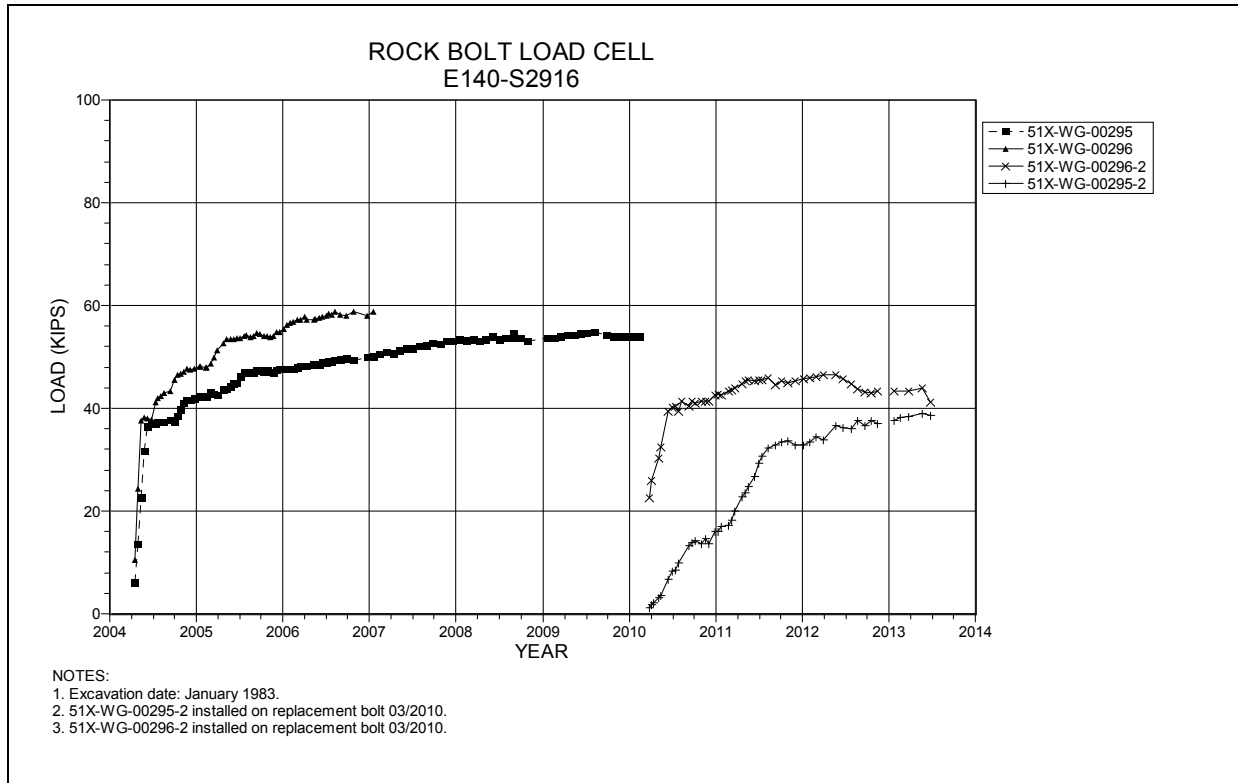

Figure 4-277 Rock Bolt Load Cells
E140 S2916

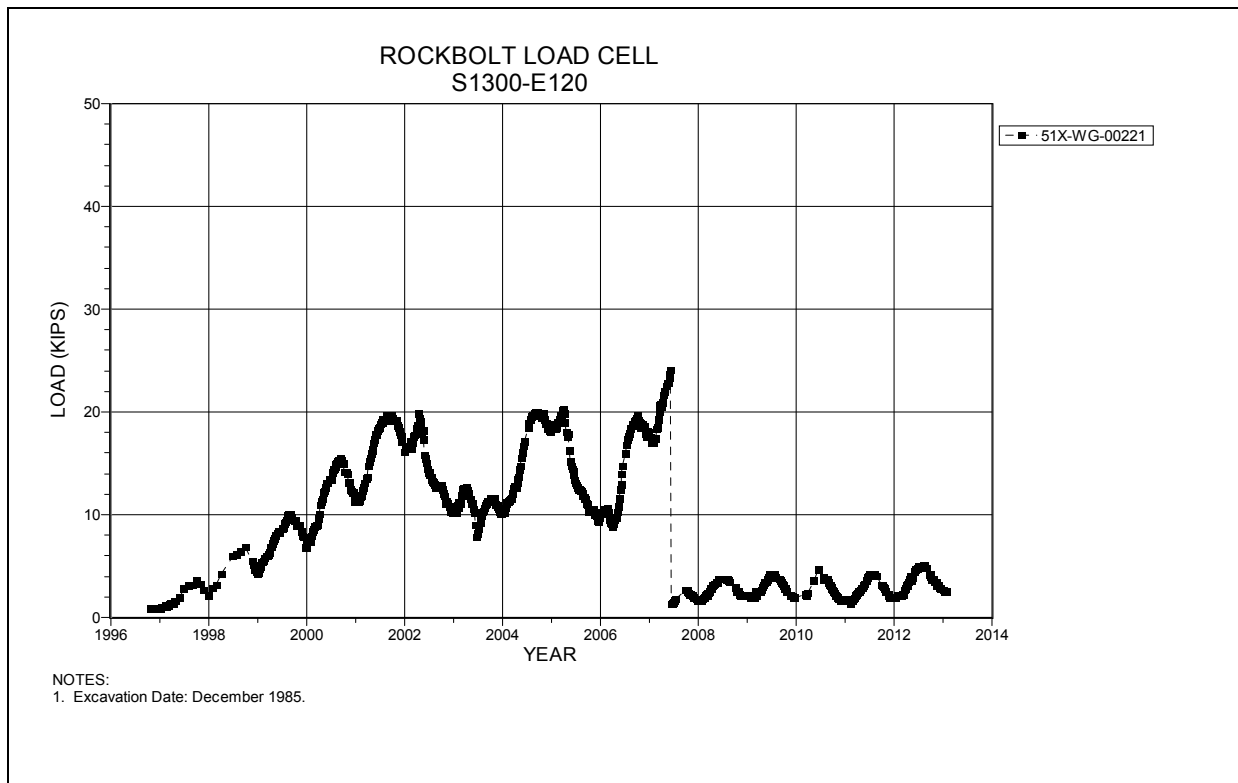

Figure 4-278 Rock Bolt Load Cell
S1300 E120

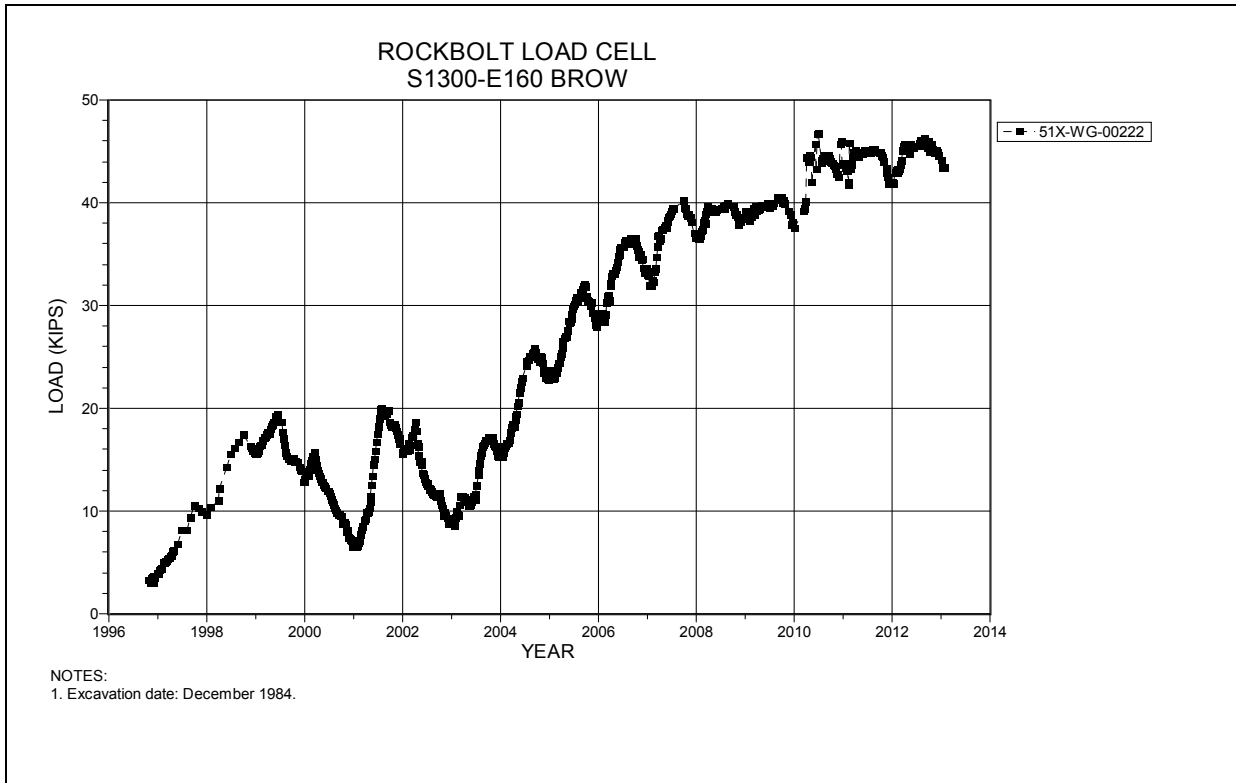

Figure 4-279 Rock Bolt Load Cell
S1300 E160

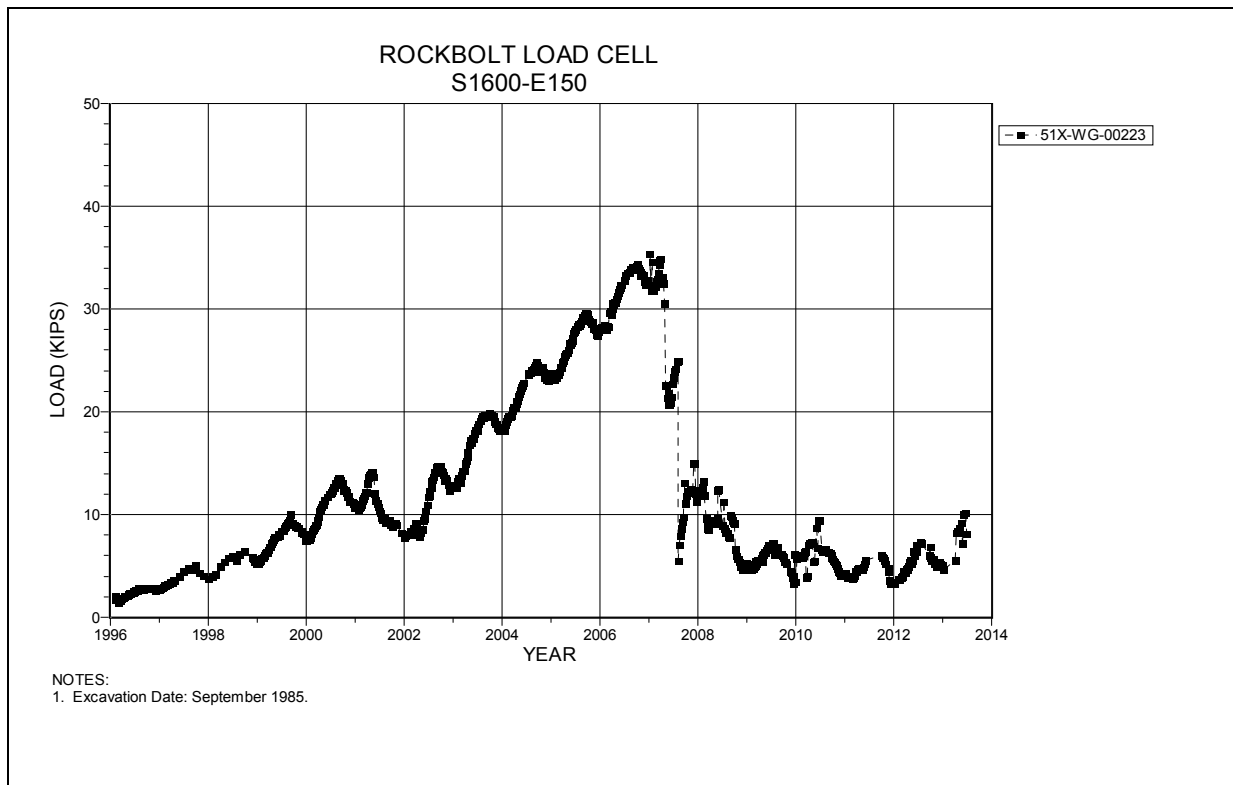

Figure 4-280 Rock Bolt Load Cell
S1600 E150

5.0 Instrumentation Summary for the Waste Disposal Area

This chapter presents a summary of the data collected from instruments located in the Waste Disposal Area at the WIPP. Table 5-1 presents data and analysis of the access drifts associated with Panel 1. Plots of the instrument data are presented as Figures 5-1 through 5-14.

Table 5-2 presents data and analysis of the access drifts associated with Panel 2. Plots of the instrument data are presented as Figures 5-15 and 5-16.

Panel 3 data and analysis are presented on Table 5-3. Plots of the instrument data are presented as Figures 5-17 through 5-18.

Table 5-4 presents data and analysis of Panel 4. The instrument data plot is presented as Figure 5-19.

Table 5-5 presents data and analysis of Panel 5. Plots of the instrument data are presented as Figures 5-20 and 5-21.

Table 5-6 presents data and analysis of Panel 6. Plots of the instrument data are presented as Figures 5-22 through 5-62.

Table 5-7 presents data and analysis of Panel 7. Plots of the instrument data are presented as Figures 5-63 through 5-122.

Table 5-1
Panel 1 Access Drifts Data Analysis

Convergence Points									
Field Tag	Location	Figure Number	Last Reading 2012 to 2013		Cumulative Displacement (inches)	Closure Rate 2012 to 2013 (in/year)	Closure Rate 2011 to 2012 (in/year)	Rate Change Percent	Comments
			Date	Inches					
S1600-E311-2 A-C	S1600-E311	5-1	06/24/13	17.706	23.153	0.9	0.9	0%	
S1600-E332-3 A-C	S1600-E332	5-2	06/24/13	17.231	21.658	1.0	1.0	0%	
S1600-E357-2 A-C	S1600-E357	5-3	06/24/13	20.081	25.479	1.2	1.3	-8%	
S1600-E382-2 A-C	S1600-E382	5-4	06/24/13	19.818	25.198	1.1	1.2	-8%	
S1600-E407-2 A-G	S1600-E407	5-5	06/24/13	22.337	27.779	1.5	1.4	7%	
S1600-E407-2 B-F	S1600-E407	5-5	06/24/13	20.628	25.634	1.3	1.3	0%	
S1600-E407-2 H-L	S1600-E407	5-5	06/24/13	21.679	26.744	1.4	1.4	0%	
S1600-E432-2 A-C	S1600-E432	5-6	06/24/13	26.120	32.879	1.7	1.8	-6%	
S1600-E453 A-C	S1600-E453	5-7	01/03/13	5.523	5.523	0.7	0.7	0%	Inaccessible since Jan. 2013.
S1600-E453 B-D	S1600-E453	5-7	06/24/13	5.527	5.527	0.7	0.6	17%	
S1950-E311-7 A-C	S1950-E311	5-8	06/24/13	4.249	33.640	1.4	1.5	-7%	
S1950-E311-3 B-D	S1950-E311	5-8	06/24/13	19.213	32.214	1.3	1.4	-7%	
S1950-E332-4 A-C	S1950-E332	5-9	06/24/13	22.369	40.971	1.7	1.9	-11%	
S1950-E332-4 B-D	S1950-E332	5-9	06/24/13	17.901	35.847	1.8	1.9	-5%	
S1950-E357-7 A-C	S1950-E357	5-10	06/24/13	28.763	48.927	2.5	2.5	0%	
S1950-E357-4 B-D	S1950-E357	5-10	06/24/13	18.949	37.408	1.9	1.9	0%	
S1950-E382-5 A-C	S1950-E382	5-11	06/24/13	33.801	52.436	2.9	2.9	0%	
S1950-E382-3 B-D	S1950-E382	5-11	06/24/13	25.983	40.365	2.0	1.9	5%	
S1950-E407-4 A-G	S1950-E407	5-12	06/24/13	33.307	55.131	2.7	2.8	-4%	
S1950-E407-3 H-L	S1950-E407	5-12	06/24/13	32.360	53.092	2.5	2.5	0%	
S1950-E407-3 D-J	S1950-E407	5-13	06/24/13	27.057	41.234	2.0	2.0	0%	
S1950-E432-3 A-C	S1950-E432	5-14	06/24/13	32.658	54.453	2.6	2.7	-4%	
S1950-E432-3 B-D	S1950-E432	5-14	06/24/13	25.335	39.736	1.9	1.9	0%	

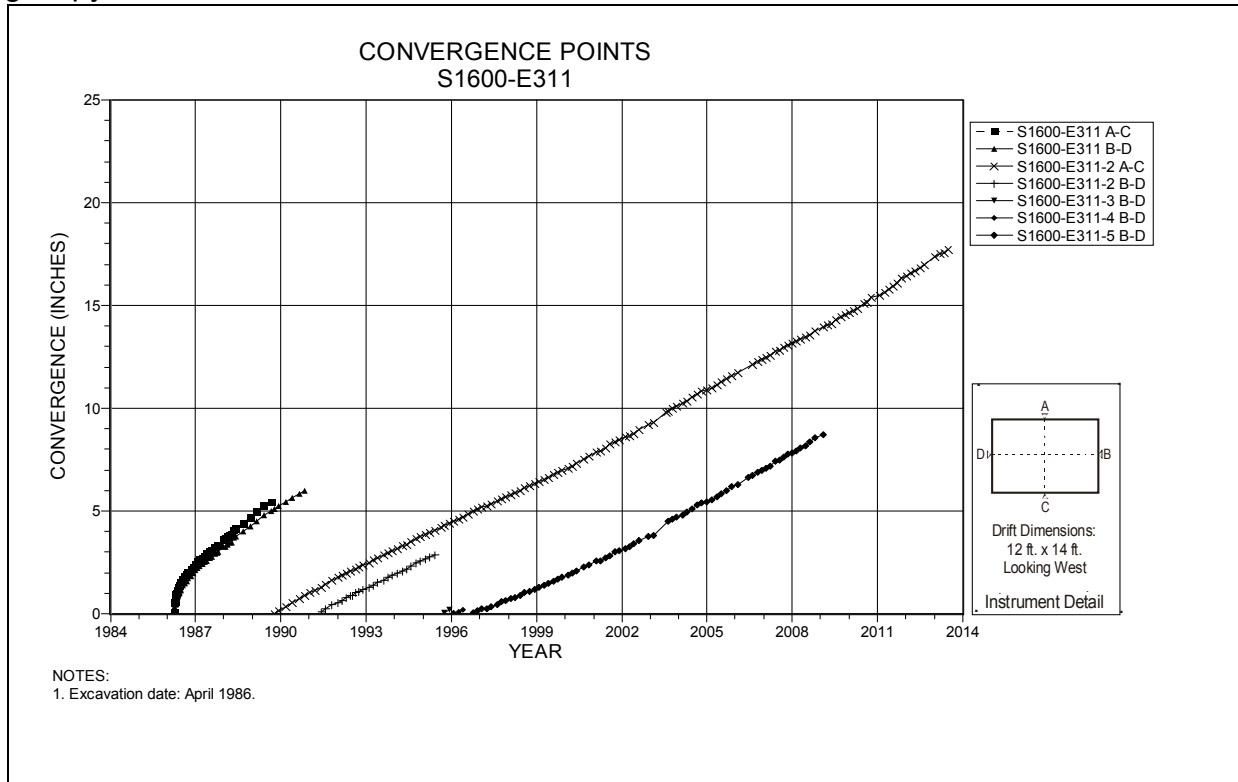

Figure 5-1 Convergence Point Array
S1600 E311 – All Chords

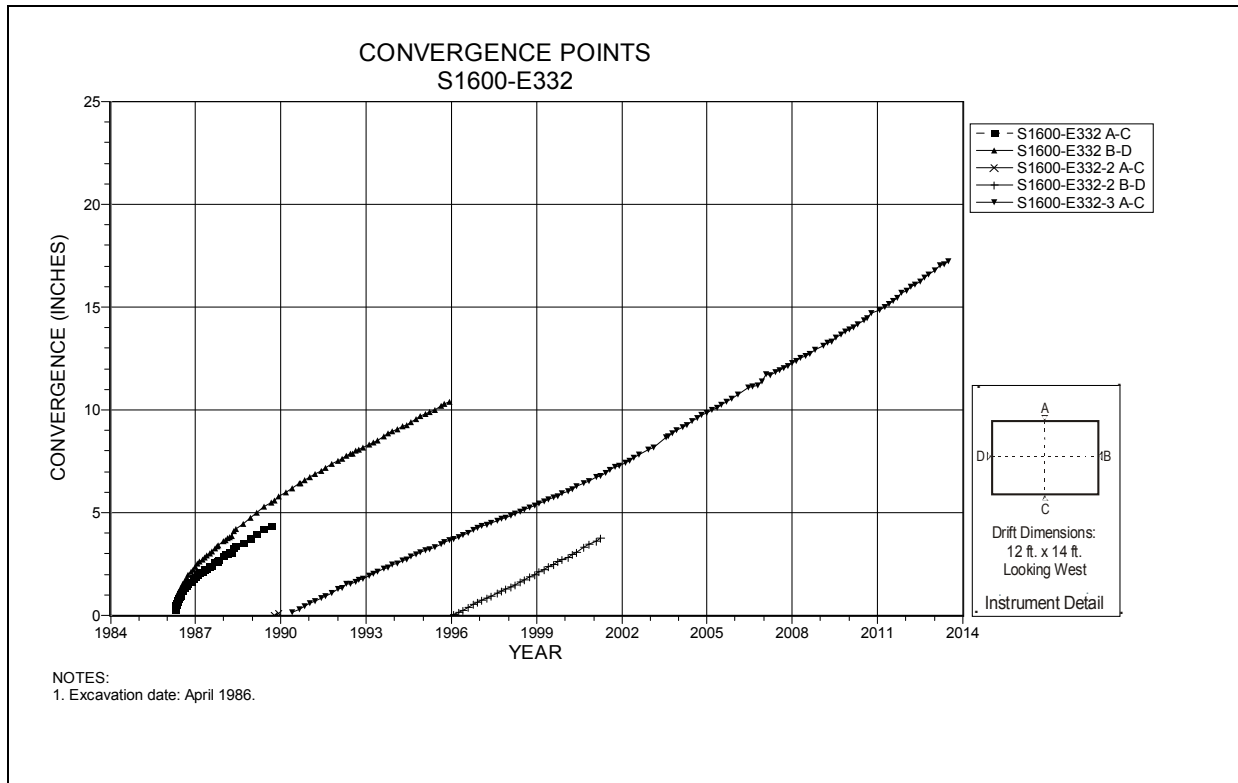

Figure 5-2 Convergence Point Array
S1600 E332 – All Chords

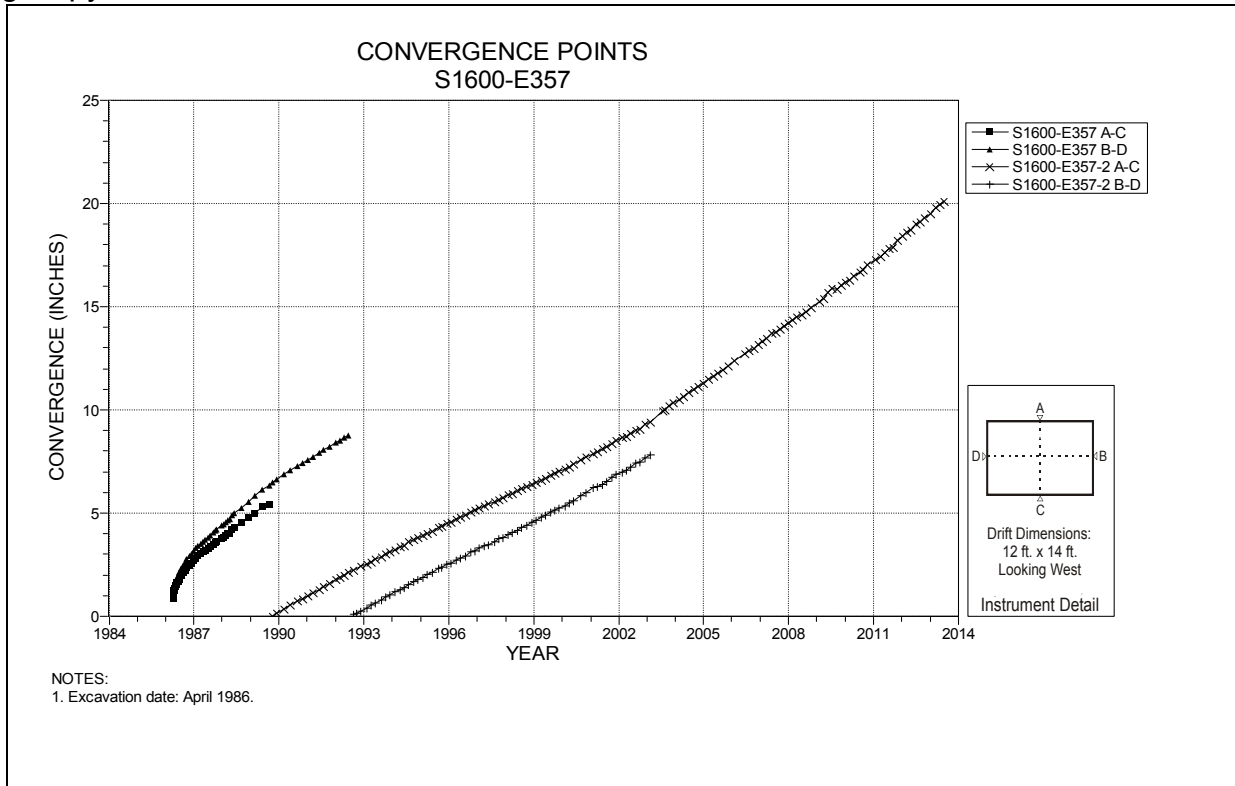

Figure 5-3 Convergence Point Array
S1600 E357 – All Chords

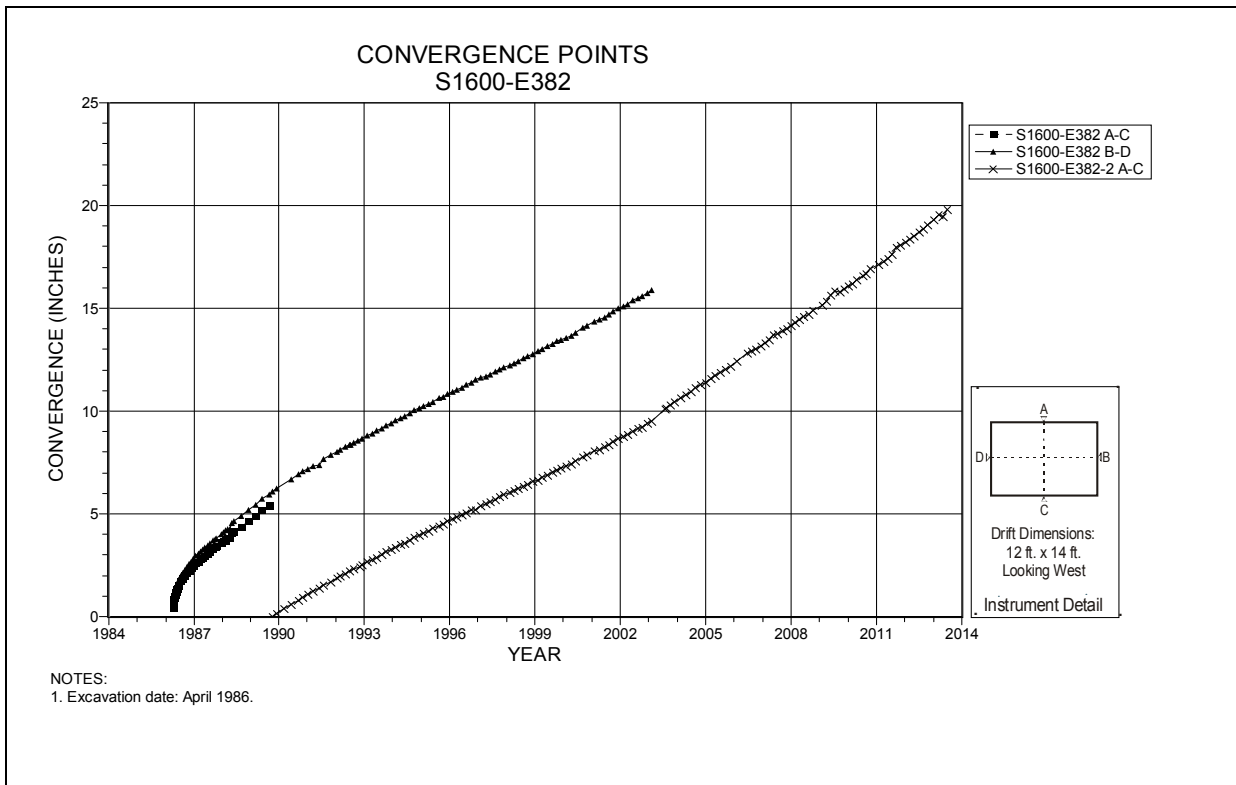

Figure 5-4 Convergence Point Array
S1600 E382 – All Chords

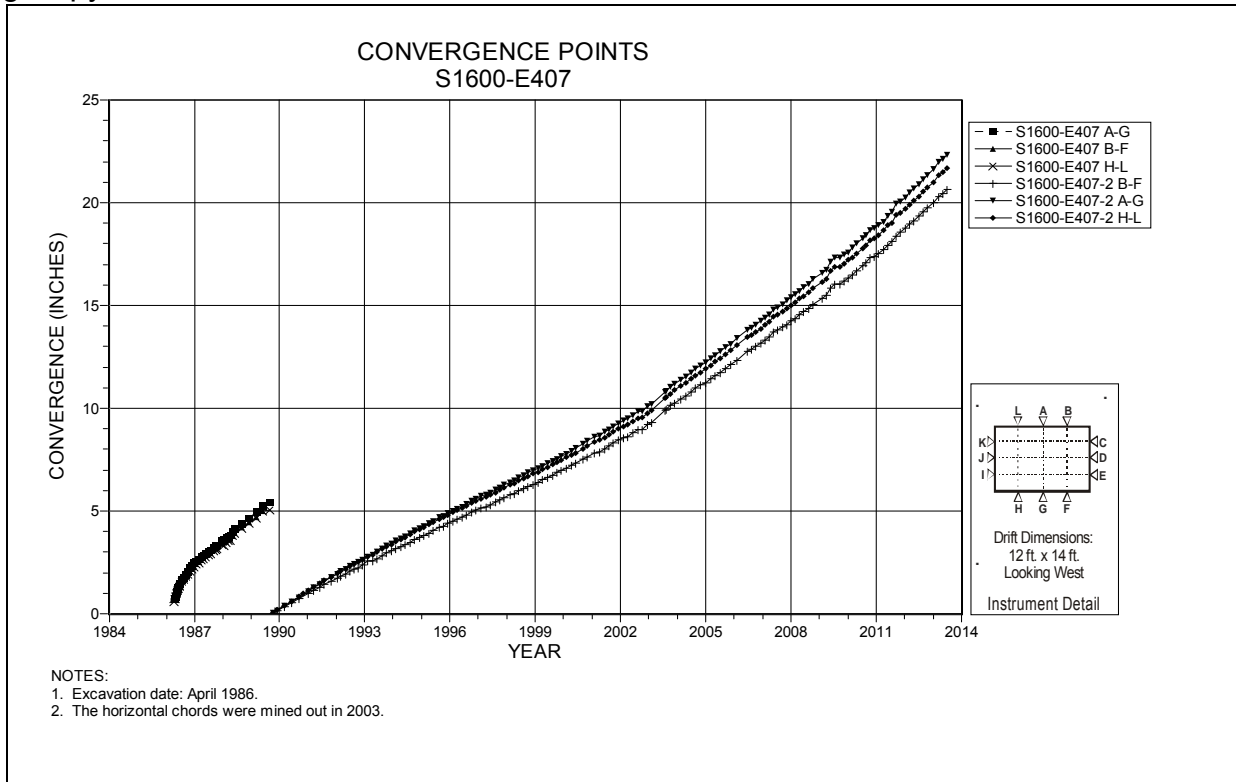

Figure 5-5 Convergence Point Array
S1600 E407 – Roof to Floor

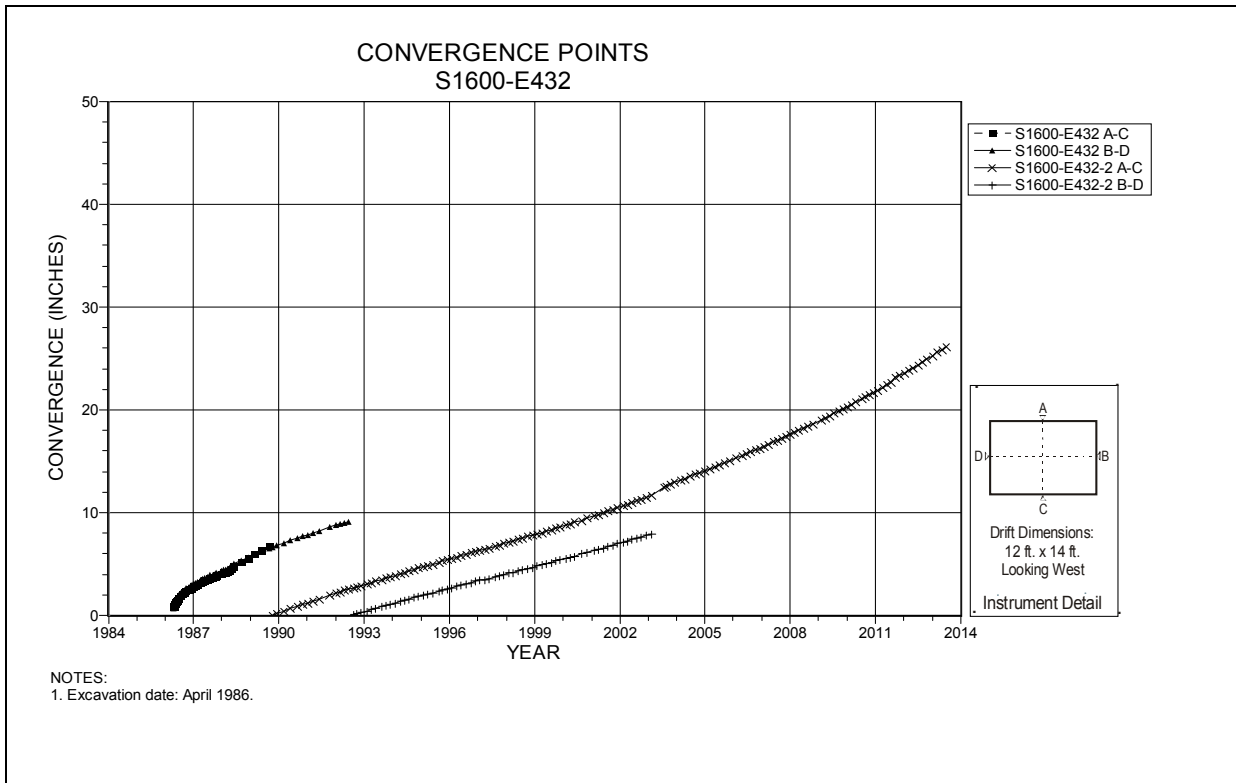

Figure 5-6 Convergence Point Array
S1600 E432 – All Chords

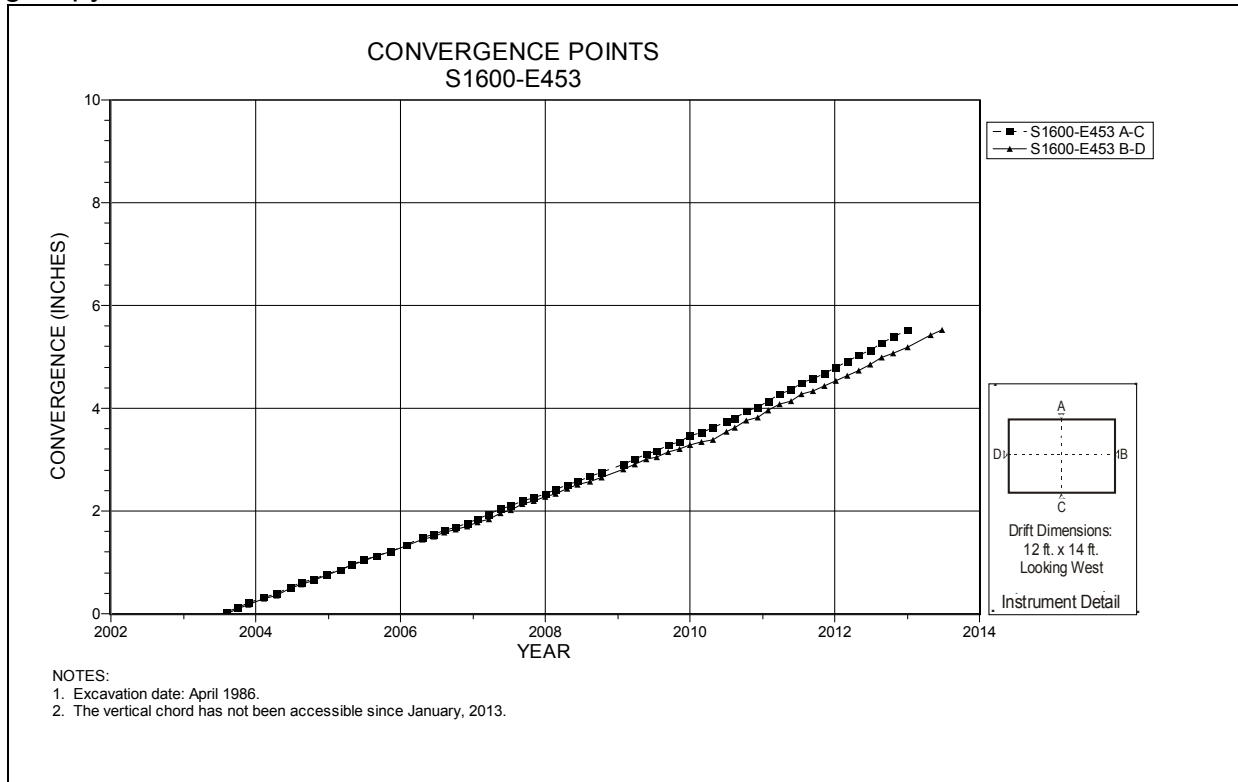

Figure 5-7 Convergence Point Array
S1600 E453 – All Chords

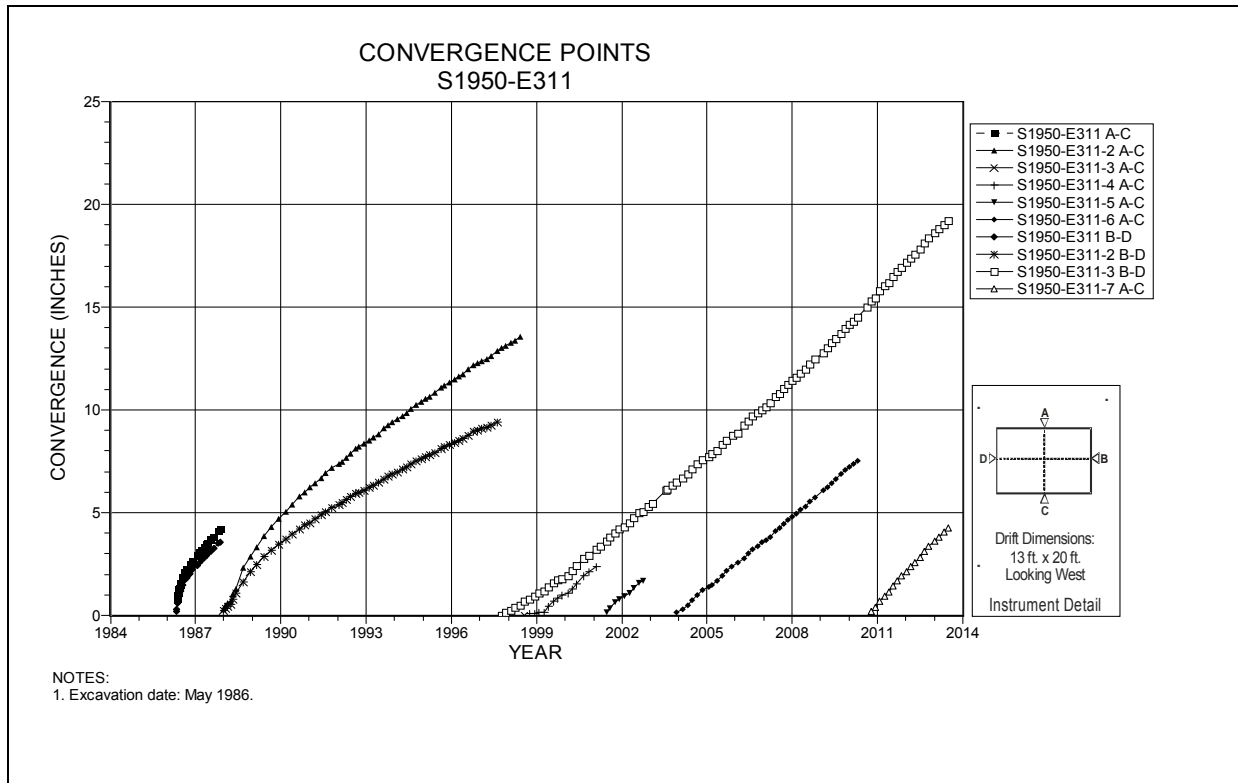

Figure 5-8 Convergence Point Array
S1950 E311 – All Chords

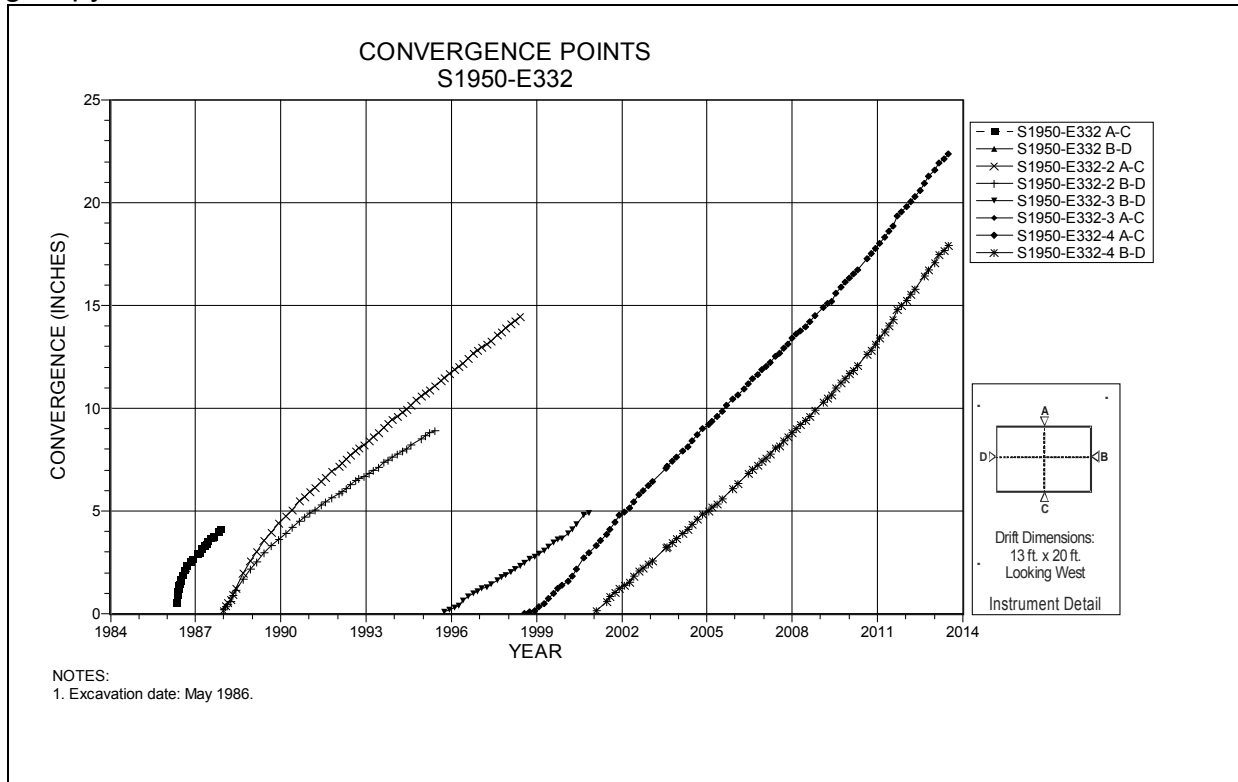

Figure 5-9 Convergence Point Array
S1950 E332 – All Chords

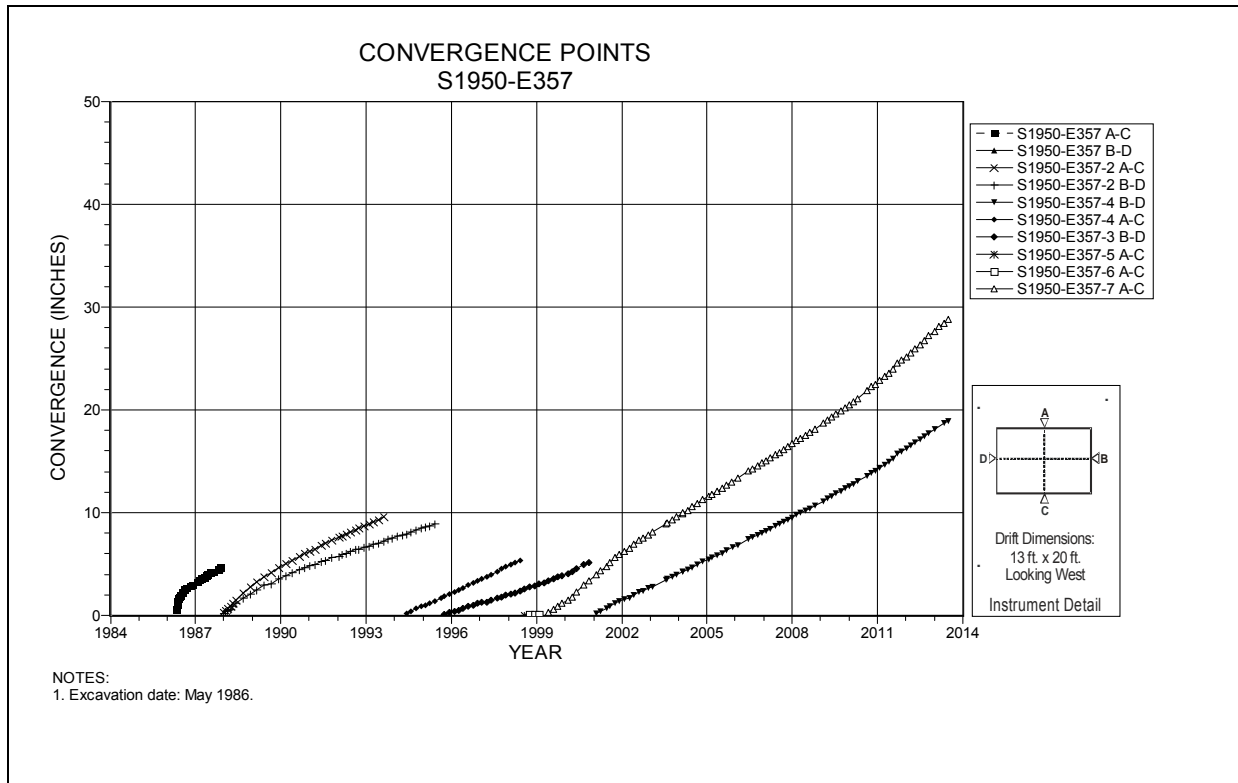

Figure 5-10 Convergence Point Array
S1950 E357 – All Chords

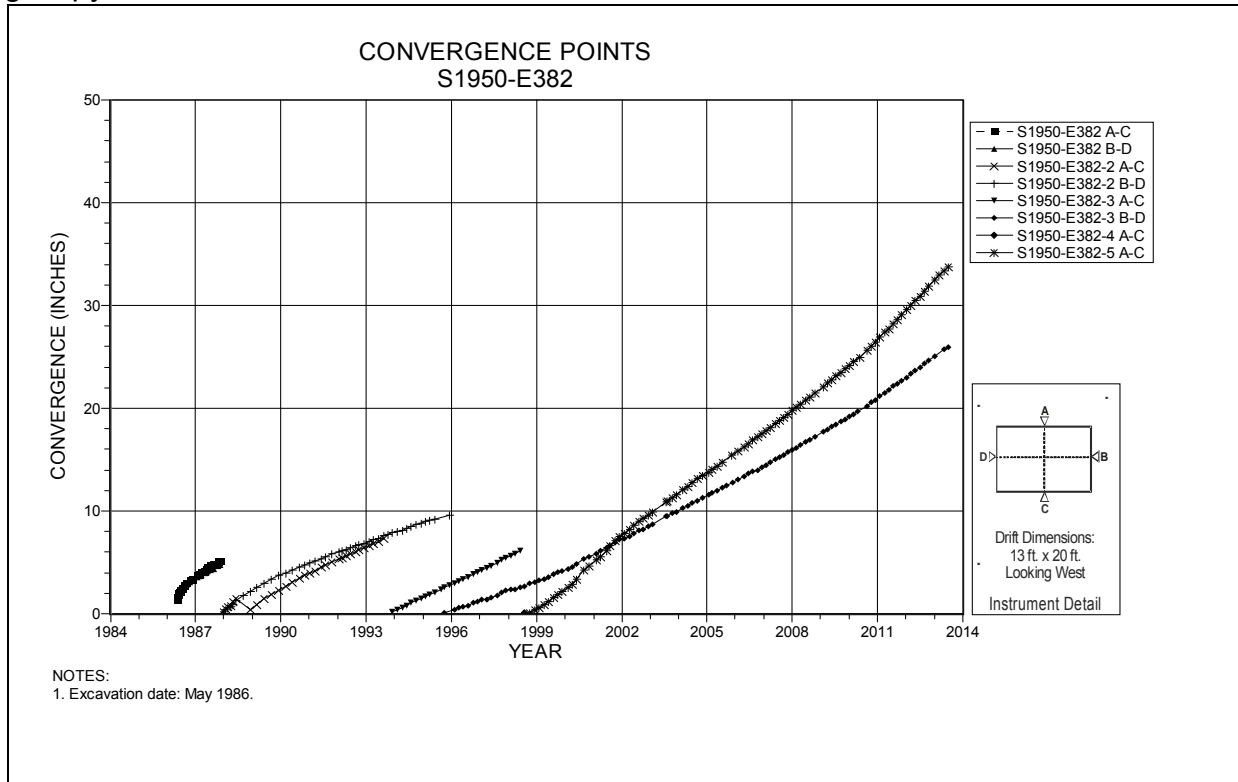

Figure 5-11 Convergence Point Array
S1950 E382 – All Chords

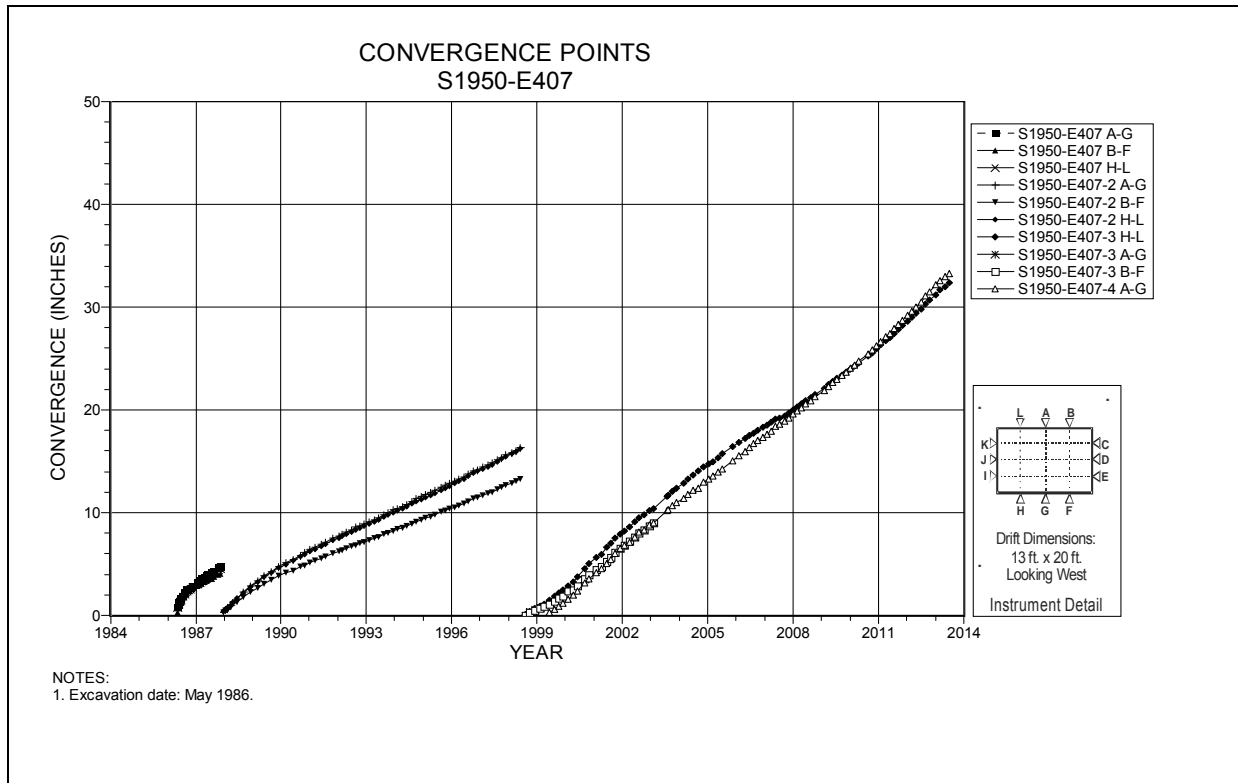

Figure 5-12 Convergence Point Array
S1950 E407 – Roof to Floor

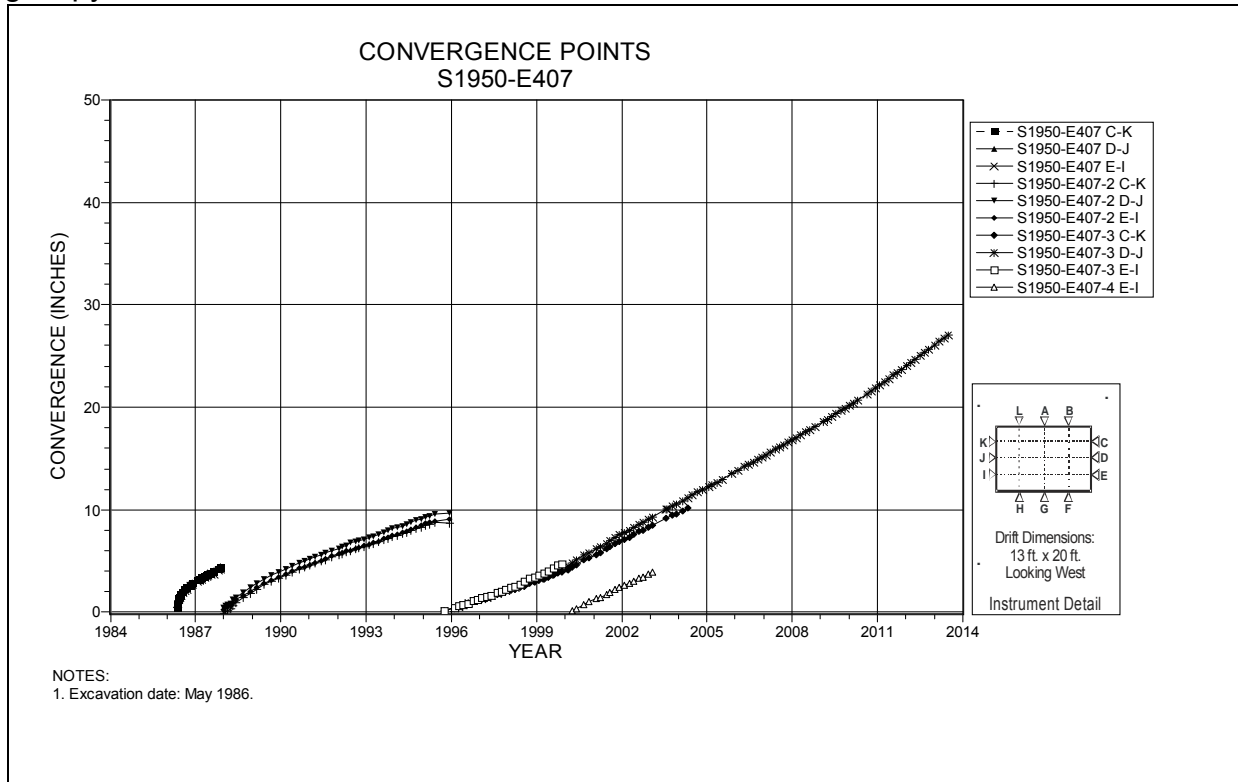

Figure 5-13 Convergence Point Array
S1950 E407 – Rib to Rib

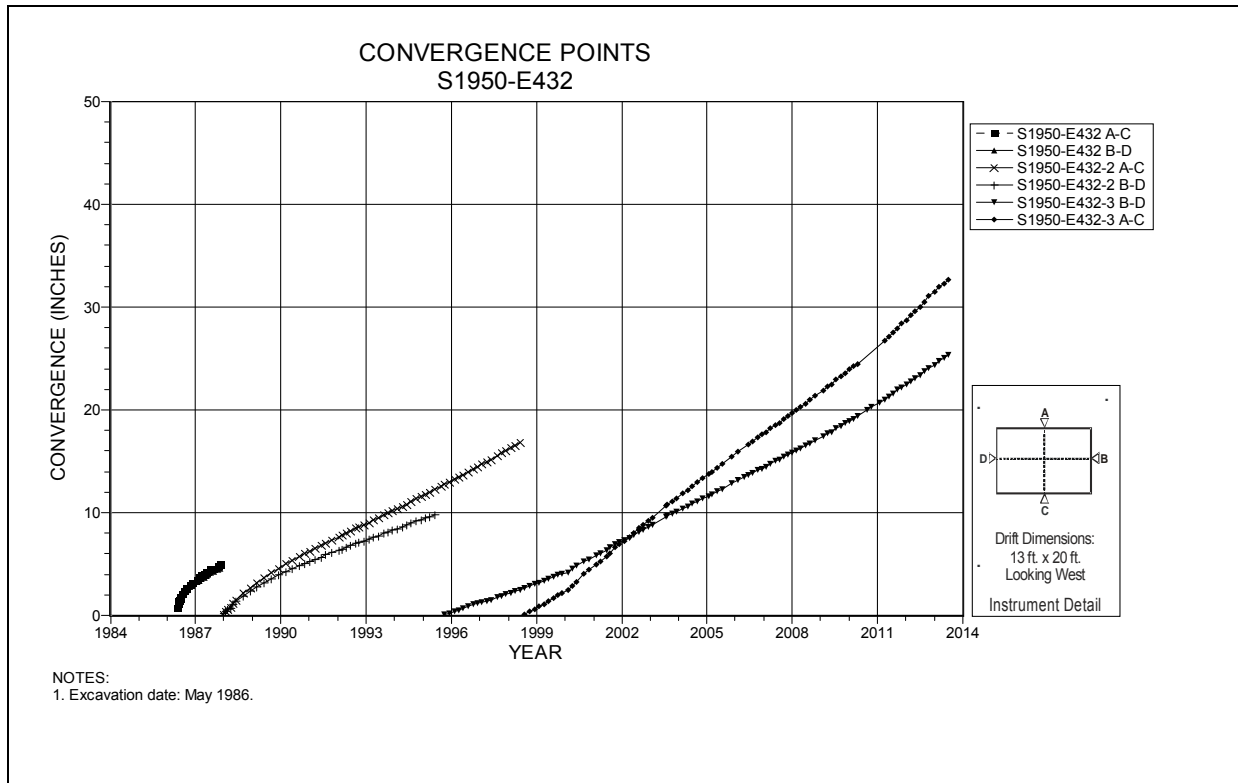

Figure 5-14 Convergence Point Array
S1950 E432 – All Chords

**Table 5-2
Panel 2 Access Drifts Data Analysis**

Convergence Points									
Field Tag	Location	Figure Number	Last Reading 2012 to 2013		Cumulative Displacement (inches)	Closure Rate 2012 to 2013 (in/year)	Closure Rate 2011 to 2012 (in/year)	Rate Change Percent	Comments
			Date	Inches					
S2180-E410-2 A-C	S2180-E410	5-15	06/10/13	12.256	17.053	1.6	1.5	7%	
S2180-E410 B-D	S2180-E410	5-15	06/10/13	22.490	22.490	2.5	2.3	9%	
S2520-E410-3 A-C	S2520-E410	5-16	06/10/13	28.023	36.159	3.6	3.5	3%	

Table 5- Panel 2 Access Drifts Data Analysis

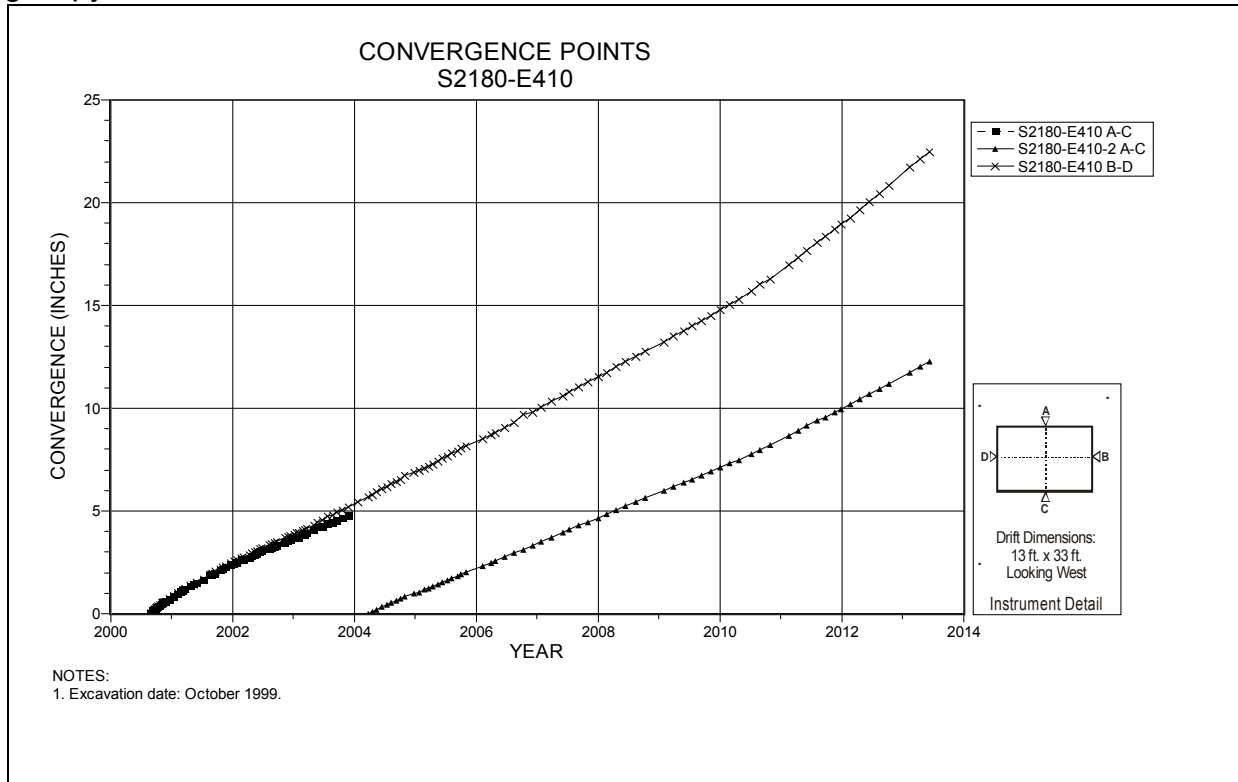

Figure 5-15 Convergence Point Array
S2180 E410 – All Chords

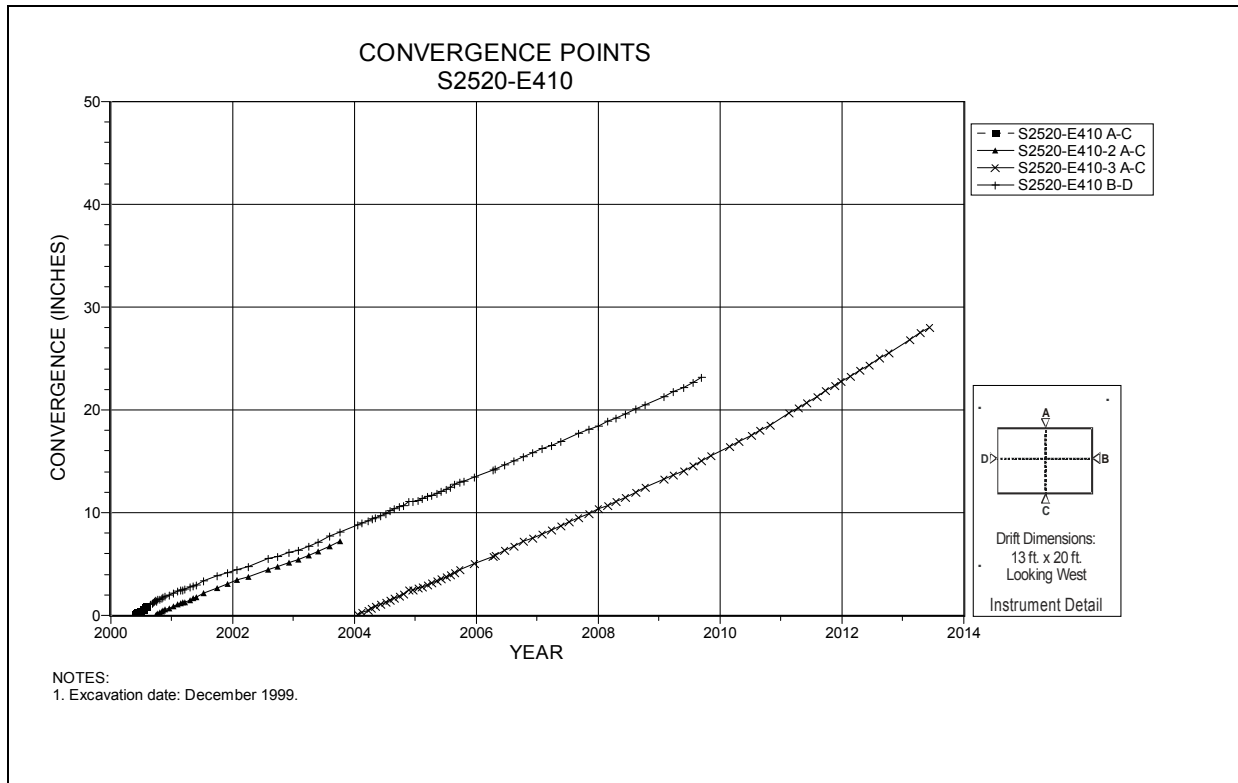

Figure 5-16 Convergence Point Array
S2520 E410 – All Chords

**Table 5-3
Panel 3 Access Drift Data Analysis**

Convergence Points									
Field Tag	Location	Figure Number	Last Reading 2012 to 2013		Cumulative Displacement (inches)	Closure Rate 2012 to 2013 (in/year)	Closure Rate 2011 to 2012 (in/year)	Rate Change Percent	Comments
			Date	Inches					
S2750-E410 A-C	S2750-E410	5-17	06/10/13	30.369	30.369	4.6	4.5	2%	
S2750-E410 B-D	S2750-E410	5-17	06/10/13	20.348	20.348	2.6	2.4	8%	
S3080-E410-2 A-C	S3080-E410	5-18	06/10/13	32.005	34.518	5.4	4.5	20%	
S3080-E410 B-D	S3080-E410	5-18	06/10/13	23.505	23.505	2.6	2.7	-4%	

Table 5- Panel 3 Data Analysis

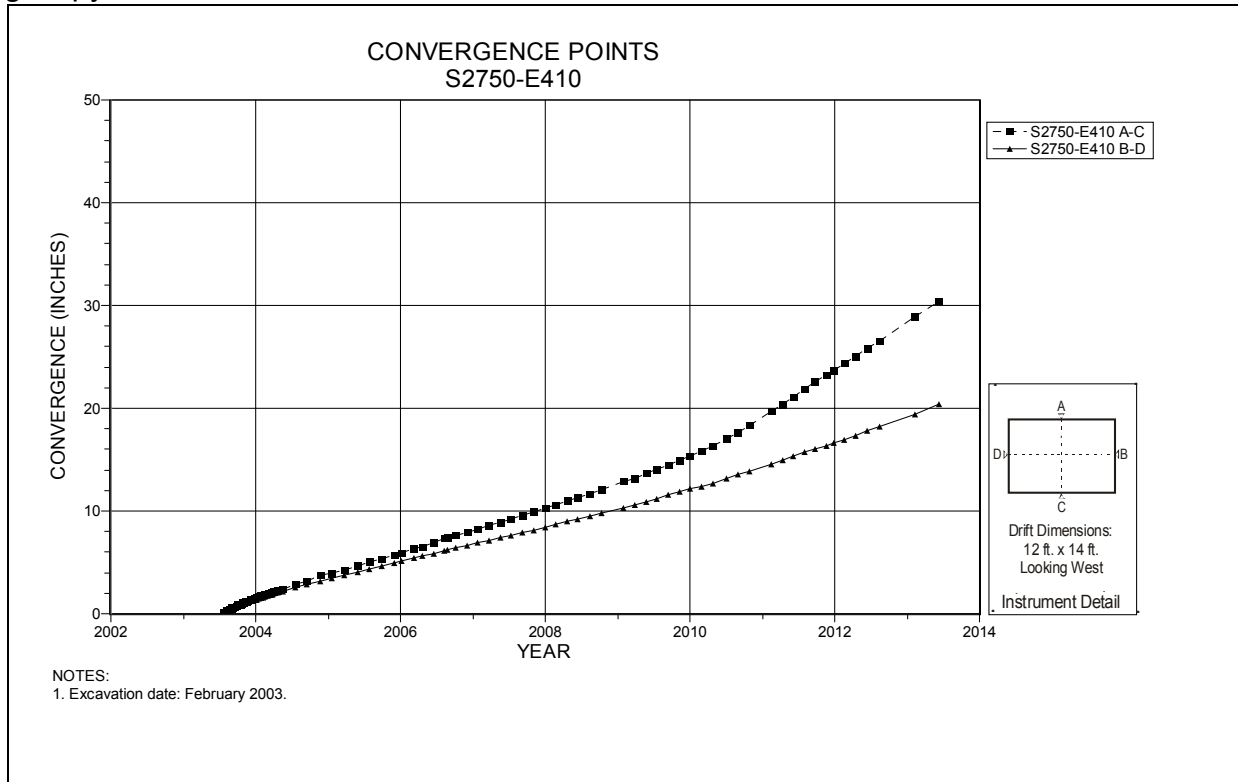

Figure 5-17 Convergence Point Array
S2750 E410 – All Chords

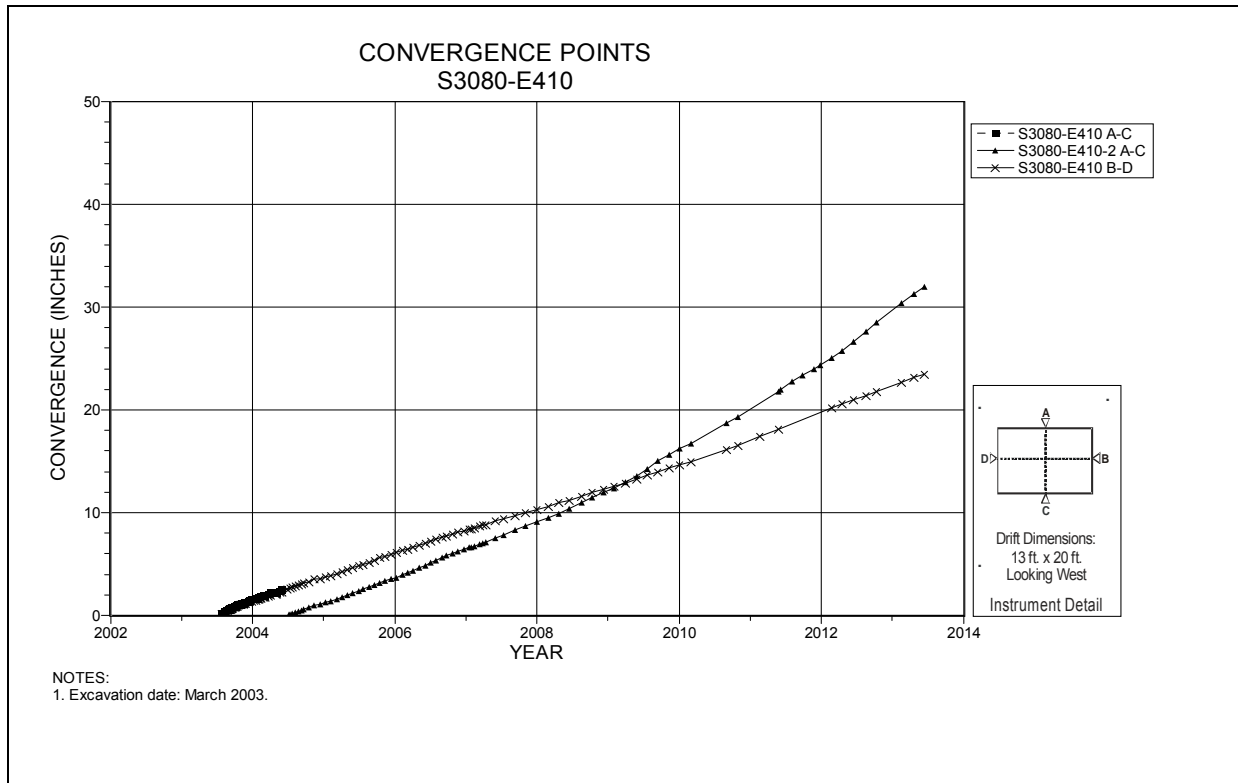

Figure 5-18 Convergence Point Array
S3080 E410 – All Chords

Table 5-4
Panel 4 Access Drift Data Analysis

Convergence Points									
Field Tag	Location	Figure Number	Last Reading 2012 to 2013		Cumulative Displacement (inches)	Closure Rate ¹ 2012 to 2013 (in/year)	Closure Rate 2011 to 2012 (in/year)	Rate Change Percent ¹	Comments
			Date	Inches					
S3310-E410 A-C	S3310-E410	5-19	02/12/13	15.465	15.465	N/A	2.0	N/A	One reading during '12 – '13 reporting period.

¹N/A – Insufficient data available to perform the calculation. This is usually due to the inability to read the instruments because of activities such as: the temporary removal of an instrument due to floor, rib or back trimming; locations blocked by equipment or waste disposal, installation timing, etc.

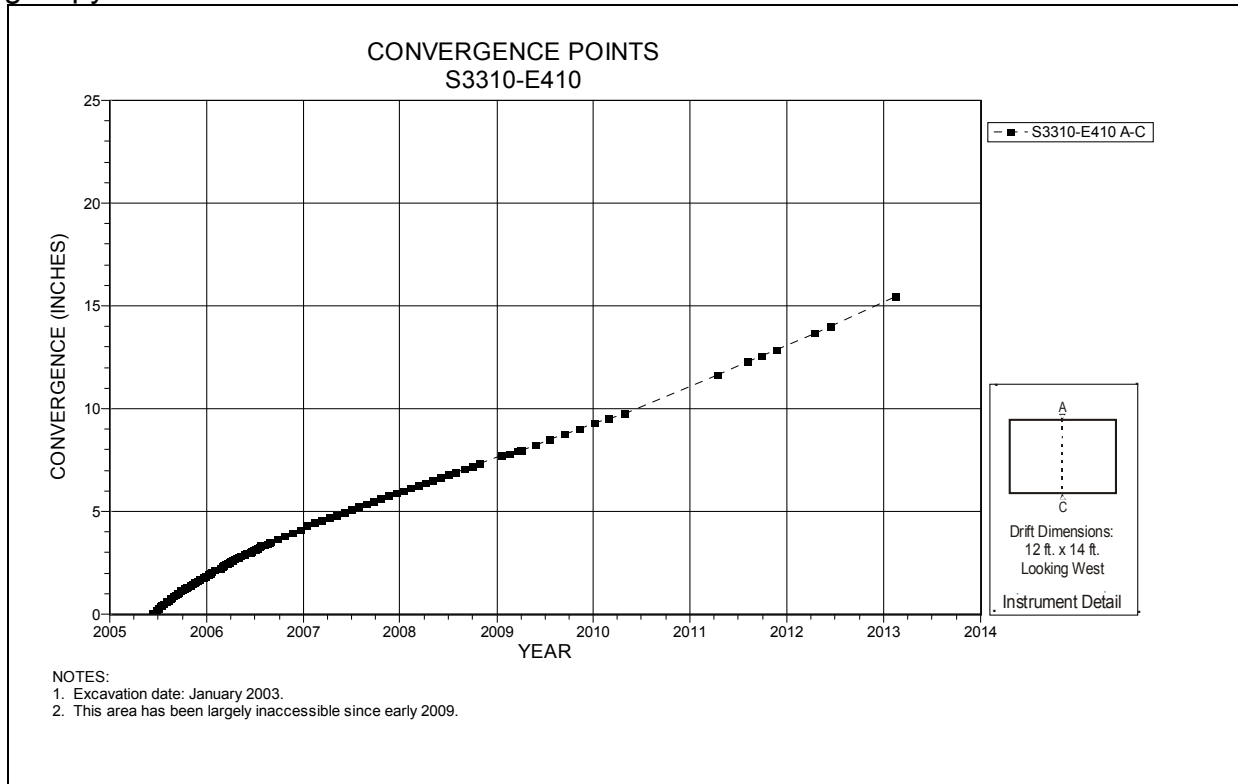

Figure 5-19 Convergence Point Array
S3310 E410 – Roof to Floor

Table 5-5
Panel 5 Data Analysis

Convergence Points									
Field Tag	Location	Figure Number	Last Reading 2012 to 2013		Cumulative Displacement (inches)	Closure Rate 2012 to 2013 (in/year)	Closure Rate 2011 to 2012 (in/year)	Rate Change Percent	Comments
			Date	Inches					
S3310-W285 A-C	S3310-W285	5-20	06/10/13	14.713	14.713	4.4	2.6	69%	
S3650-W285-2 A-C	S3650-W285	5-21	06/10/13	14.913	17.354	5.8	3.7	57%	

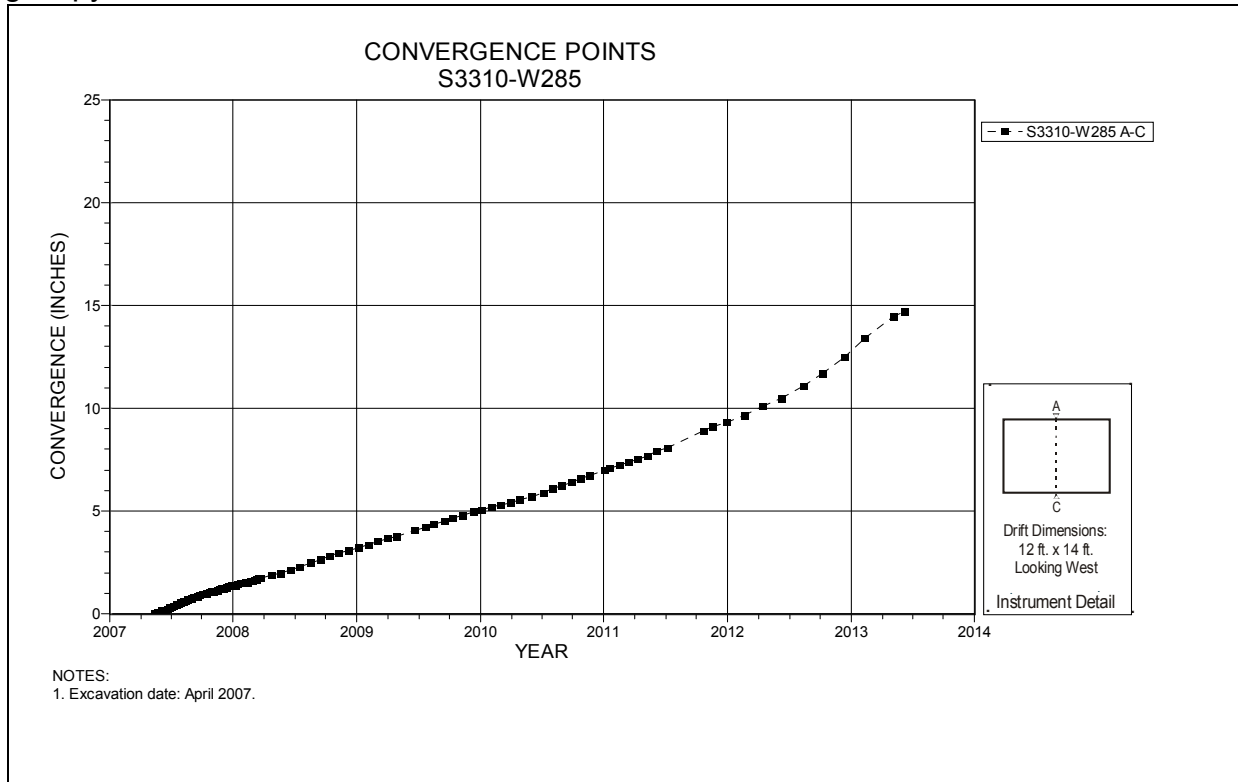

Figure 5-20 Convergence Point Array
S3310 W285 – Roof to Floor

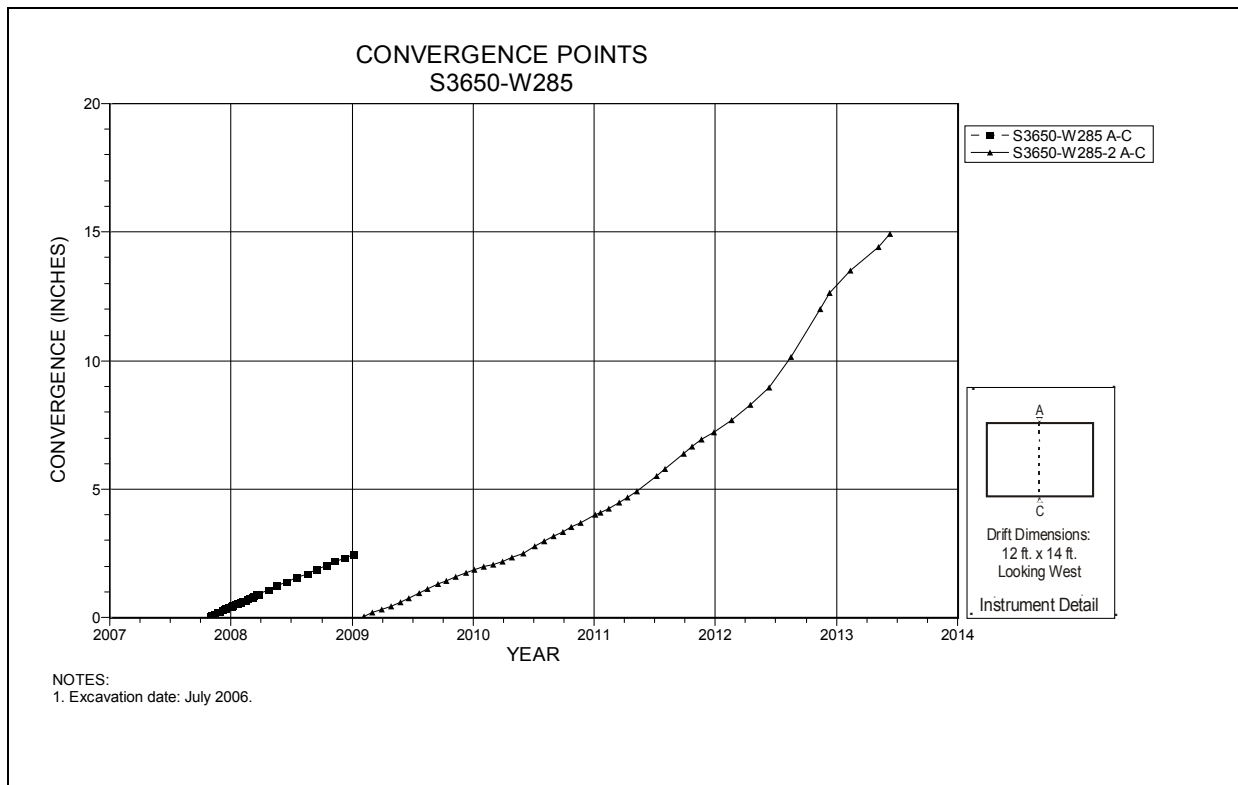

Figure 5-21 Convergence Point Array
S3650 W285 – Roof to Floor

Table 5-6
Panel 6 Data Analysis

Extensometers								
Field Tag	Location	Figure Number	Date of Last Reading	Collar Displacement Relative to Deepest Anchor (inches)	Displacement Rate 2012 to 2013 (in/year)	Displacement Rate 2011 to 2012 (in/year)	Rate Change Percent	Comments
51X-GE-00501-2	S2750-W285	5-22	06/24/13	2.316	5.9	1.9	211%	The 2011-2012 rate is from 51X-GE-00501.
51X-GE-00413-2	S2750-W585	5-23	06/28/13	6.862	2.5	2.9	-14%	
51X-GE-00414	S2750-W985	5-24	06/28/13	5.160	1.8	1.6	10%	
51X-GE-00403-2	W390-S2916	5-25	06/28/13	1.383	1.4	4.6	-70%	The 2011-2012 rate is from 51X-GE-00403.
51X-GE-00405-2	W520-S2916	5-26	06/28/13	3.644	3.8	5.1	-25%	The 2011-2012 rate is from 51X-GE-00405.
51X-GE-00406	W660-S2916	5-27	06/28/13	12.781	4.7	3.5	34%	
51X-GE-00407	W790-S2916	5-28	06/28/13	7.749	2.1	1.7	23%	
51X-GE-00408-2	W920-S2916	5-29	06/28/13	4.219	1.7	1.3	27%	Anchor "B" was used (anchor "C" has failed).
51X-GE-00409	W1050-S2916	5-30	06/28/13	6.866	2.1	1.7	22%	
51X-GE-00410	W1190-S2916	5-31	06/28/13	5.330	1.5	1.5	2%	
51X-GE-00411	S3080-W585	5-32	06/28/13	12.397	3.6	3.8	-6%	
51X-GE-00412	S3080-W985	5-33	06/28/13	5.795	1.9	1.6	21%	

Convergence Points									
Field Tag	Location	Figure Number	Last Reading 2012 to 2013		Cumulative Displacement (inches)	Closure Rate ¹ 2012 to 2013 (in/year)	Closure Rate 2011 to 2012 (in/year)	Rate Change Percent ¹	Comments
			Date	Inches					
S2750-W285-2 A-C	S2750-W285	5-34	06/24/13	21.181	25.862	7.0	7.6	-8%	
S2750-W390-2 A-C	S2750-W390	5-35	06/24/13	16.525	23.651	4.9	5.1	-4%	
S2750-W460-2 A-C	S2750-W460	5-36	06/24/13	21.536	27.562	5.7	6.8	-16%	
S2750-W520-2 A-C	S2750-W520	5-37	06/24/13	16.348	23.064	4.2	5.0	-16%	
S2750-W590-2 A-C	S2750-W590	5-38	05/28/13	18.028	21.730	4.8	5.7	-16%	
S2750-W660-2 A-C	S2750-W660	5-39	05/02/13	15.625	19.715	3.9	4.9	-20%	
S2750-W725-2 A-C	S2750-W725	5-40	11/28/12	14.424	18.704	4.4	5.1	-14%	
S2750-W790-2 A-C	S2750-W790	5-41	11/28/12	13.748	18.201	4.2	4.7	-11%	
S2750-W855-2 A-C	S2750-W855	5-42	08/01/12	12.799	14.484	N/A	5.6	N/A	Waste emplacement, one reading this period.

Table 5-6
Panel 6 Data Analysis (Continued)

Convergence Points (Continued)									
Field Tag	Location	Figure Number	Last Reading 2012 to 2013		Cumulative Displacement (inches)	Closure Rate ¹ 2012 to 2013 (in/year)	Closure Rate 2011 to 2012 (in/year)	Rate Change Percent ¹	Comments
			Date	Inches					
W390-S2833-3 A-C	W390-S2833	5-43	05/01/13	2.894	31.524	6.9	8.2	-16%	
W390-S2916-3 A-C	W390-S2916	5-44	05/28/13	2.101	29.299	4.3	6.7	-36%	
W390-S2916 B-D	W390-S2916	5-44	05/28/13	7.264	7.264	3.7	3.3	12%	
W390-S2998-2 A-C	W390-S2998	5-45	05/28/13	15.086	24.139	4.3	4.6	-7%	
W520-S2833-2 A-C	W520-S2833	5-46	06/24/13	14.799	20.807	3.9	4.9	-20%	
W520-S2916-2 A-C	W520-S2916	5-47	06/24/13	20.257	26.360	5.5	7.1	-23%	
W520-S2916 B-D	W520-S2916	5-47	06/24/13	8.767	8.767	3.3	3.2	3%	
W520-S2998-2 A-C	W520-S2998	5-48	06/24/13	14.482	20.192	4.0	4.7	-15%	
W660-S2833-2 A-C	W660-S2833	5-49	05/02/13	14.966	19.260	4.3	5.3	-19%	
W660-S2916-2 A-C	W660-S2916	5-50	04/01/13	16.887	21.949	6.4	5.9	8%	
W660-S2916 B-D	W660-S2916	5-50	03/05/13	8.239	8.239	3.4	3.6	-6%	
W660-S2998-2 A-C	W660-S2998	5-51	03/05/13	14.516	19.306	5.3	5.2	2%	
W790-S2833-2 A-C	W790-S2833	5-52	10/23/12	12.206	17.514	5.1	4.7	9%	
W790-S2916-2 A-C	W790-S2916	5-53	10/23/12	10.943	16.207	4.3	4.2	2%	
W790-S2916 B-D	W790-S2916	5-53	10/23/12	6.793	6.793	3.4	3.3	3%	
W790-S2998-2 A-C	W790-S2998	5-54	09/24/12	9.803	14.909	4.0	3.8	5%	
S3080-W285-2 A-C	S3080-W285	5-55	06/25/13	8.964	12.931	3.2	2.8	14%	
S3080-W390-2 A-C	S3080-W390	5-56	05/28/13	11.532	19.730	3.0	3.5	-14%	
S3080-W460-2 A-C	S3080-W460	5-57	06/24/13	14.804	22.838	4.2	4.6	-9%	
S3080-W520-2 A-C	S3080-W520	5-58	06/24/13	15.424	23.895	4.1	4.8	-15%	
S3080-W585-2 A-C	S3080-W585	5-59	01/02/13	16.038	25.216	5.4	5.7	-5%	
S3080-W660-2 A-C	S3080-W660	5-60	01/02/13	13.506	20.630	4.2	4.7	-11%	
S3080-W725-2 A-C	S3080-W725	5-61	08/01/12	11.704	16.244	N/A	5.1	N/A	Waste emplacement, one reading this period.
S3080-W790-2 A-C	S3080-W790	5-62	08/01/12	12.320	18.057	N/A	5.1	N/A	Waste emplacement, one reading this period.

¹N/A – Insufficient data available to perform the calculation. This is usually due to the inability to read the instruments because of activities such as: the temporary removal of an instrument due to floor, rib or back trimming; locations blocked by equipment or waste disposal, installation timing, etc.

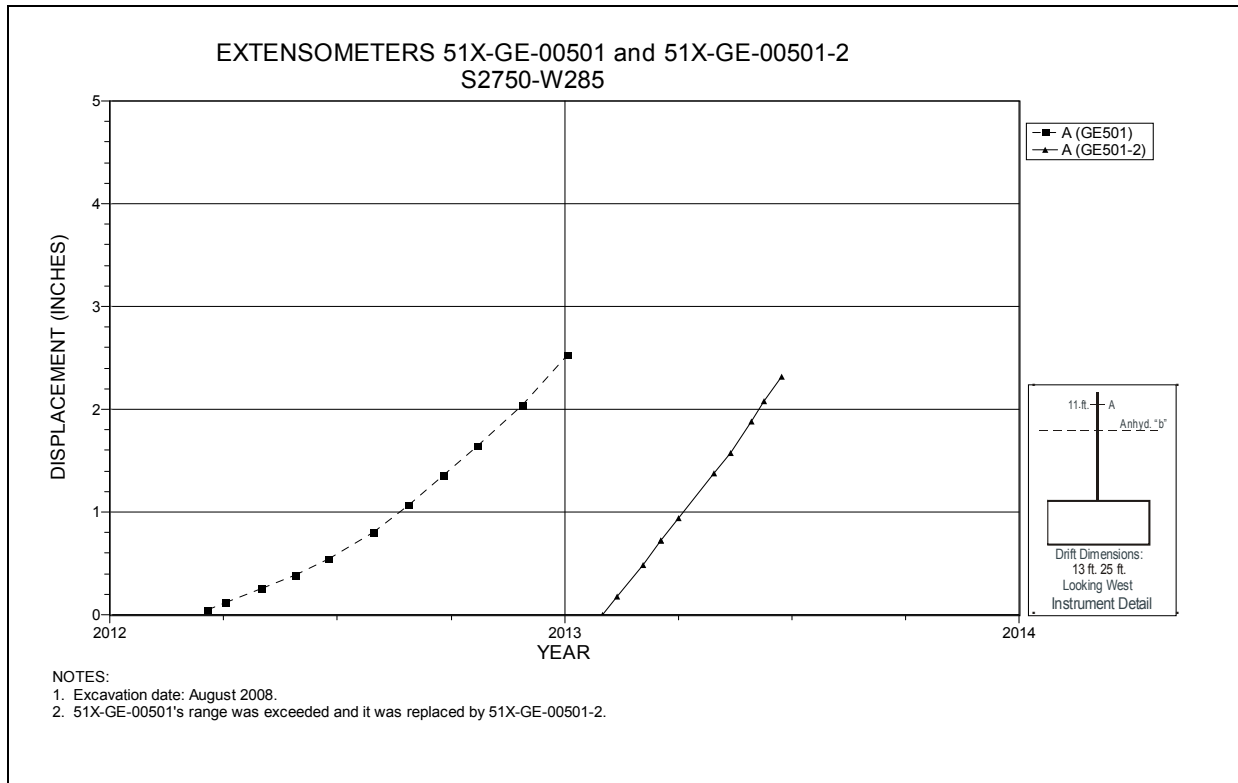

**Figure 5-22 Extensometers 51X-GE-00501 and 51X-GE-00501-2
S2750 W285 – Roof**

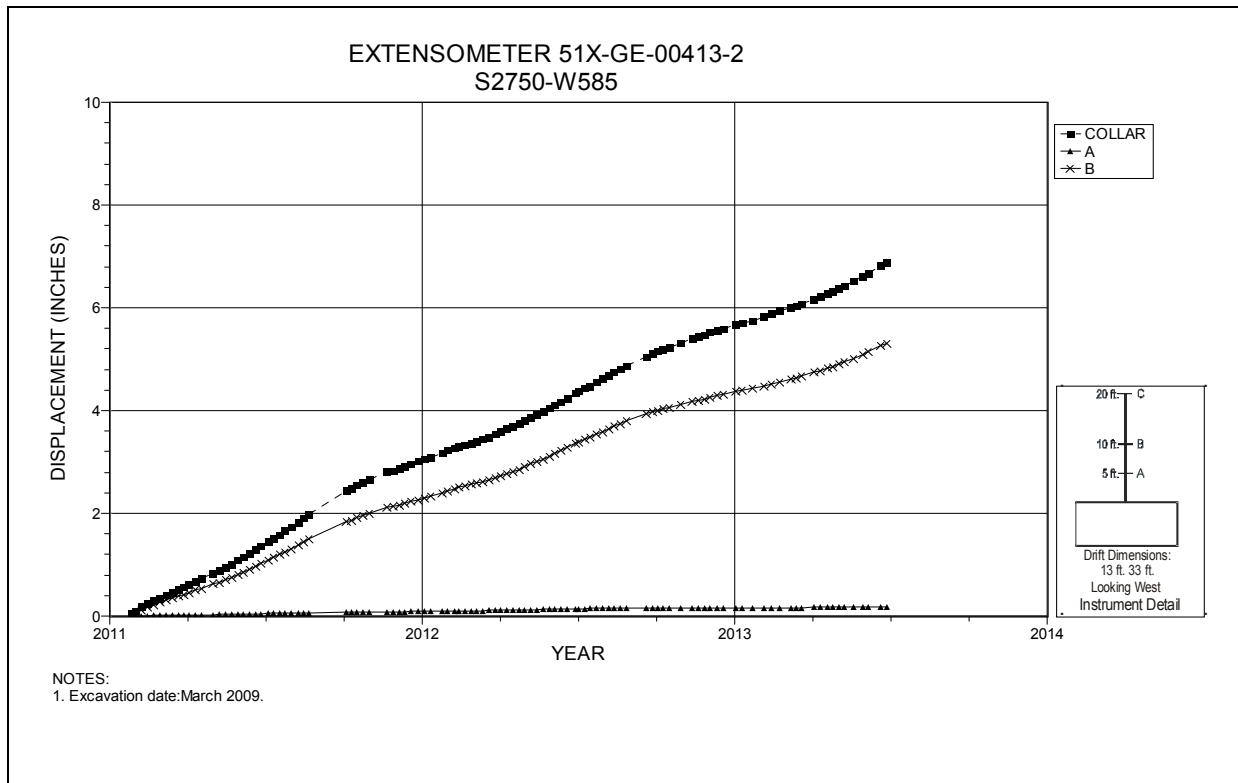

**Figure 5-23 Extensometer 51X-GE-00413-2
S2750 W585 – Roof**

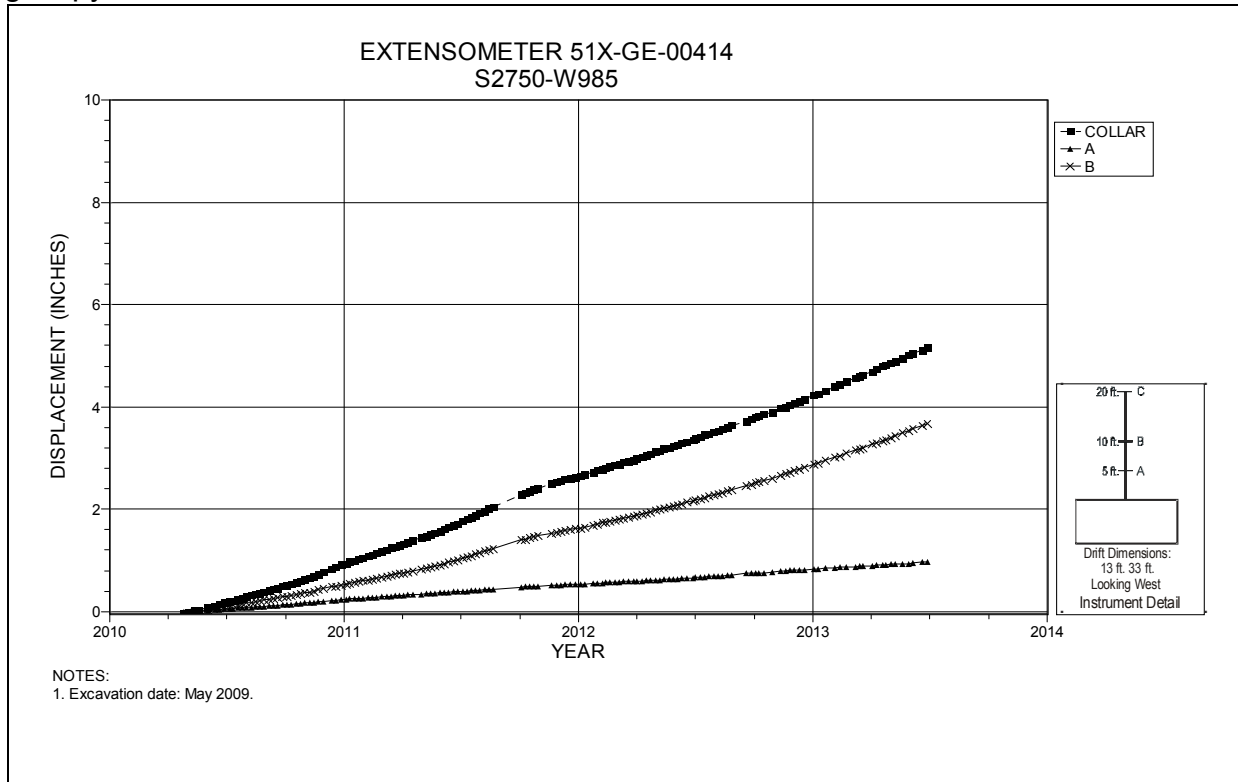

Figure 5-24 Extensometer 51X-GE-00414
S2750 W985 – Roof

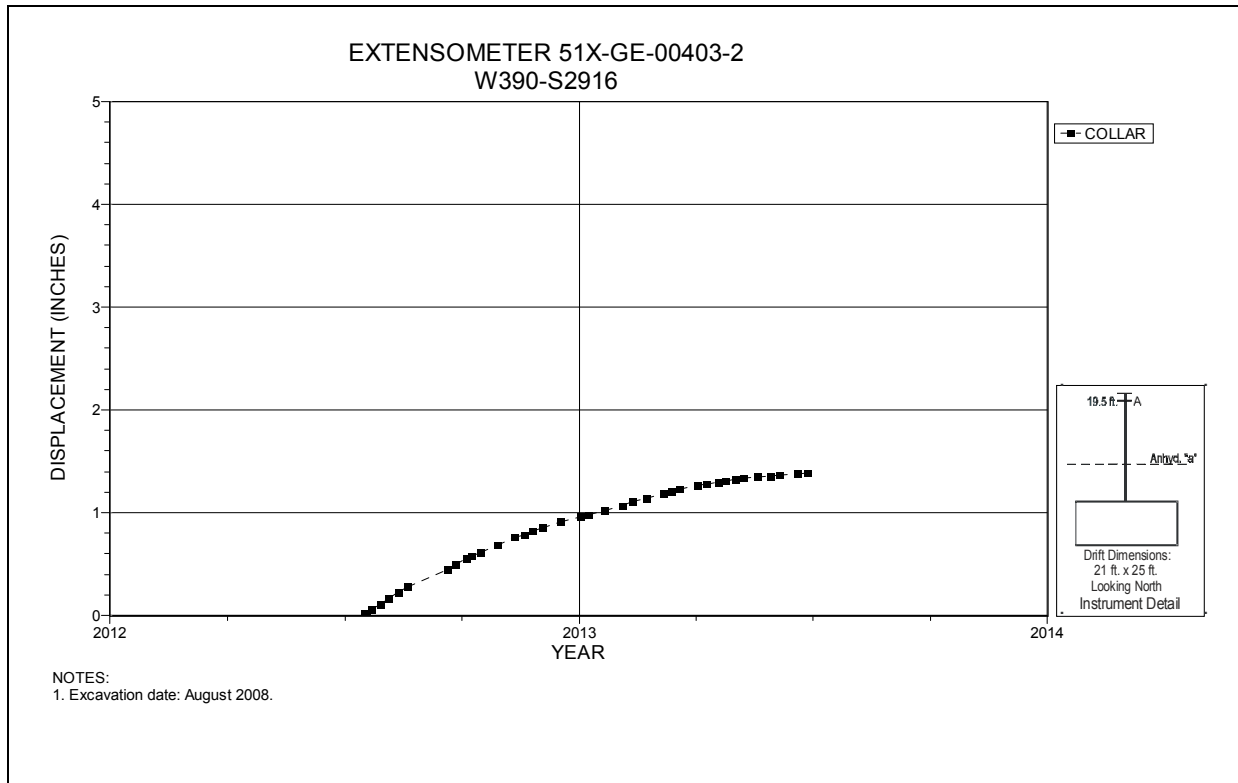

Figure 5-25 Extensometer 51X-GE-00403-2
Room 1, Panel 6 at W390 S2916 – Roof

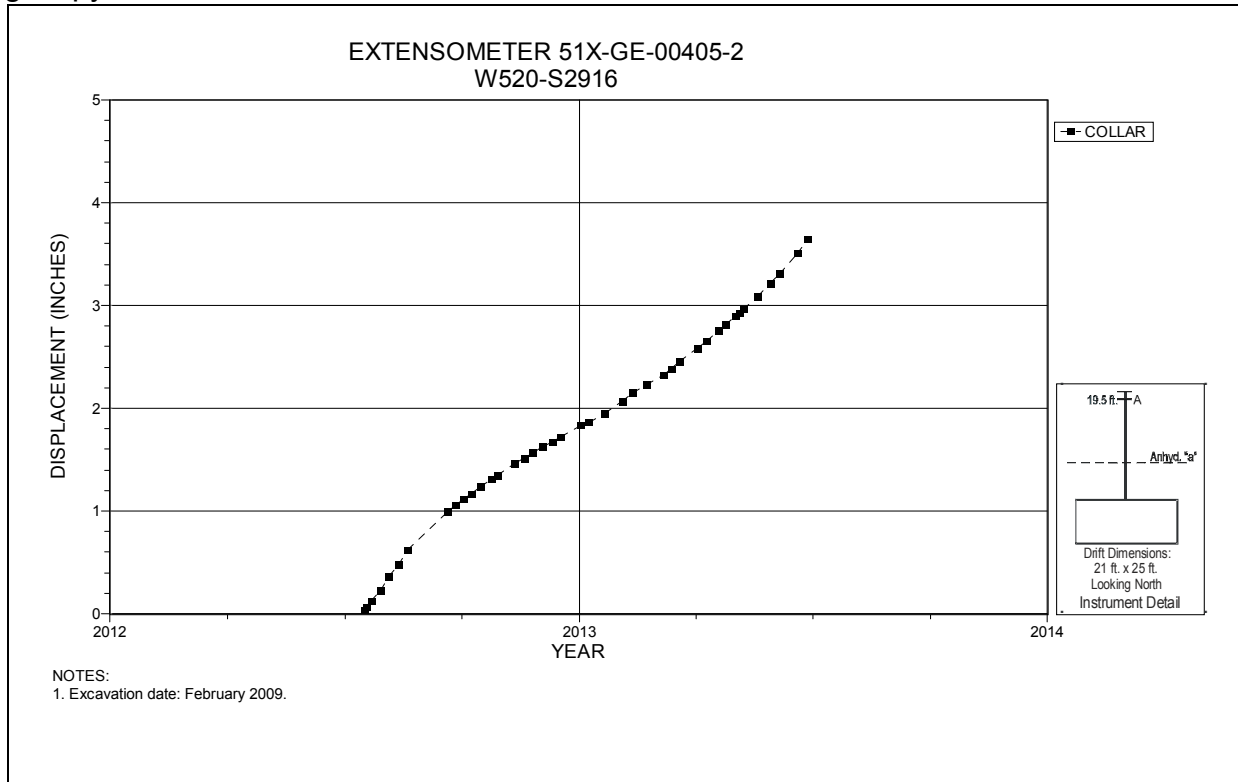

Figure 5-26 Extensometer 51X-GE-00405-2
Room 2, Panel 6 at W520 S2916 – Room Center – Roof

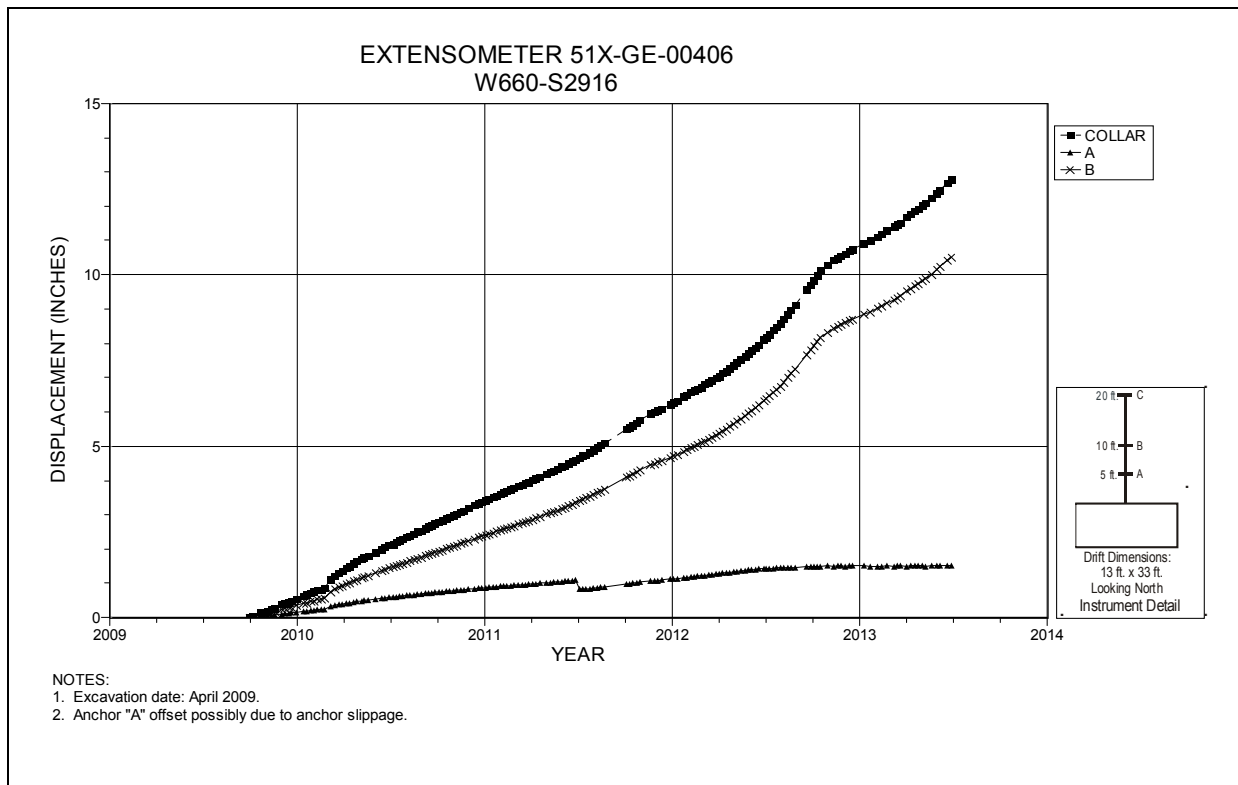

Figure 5-27 Extensometer 51X-GE-00406
Room 3, Panel 6 at W660 S2916– Room Center – Roof

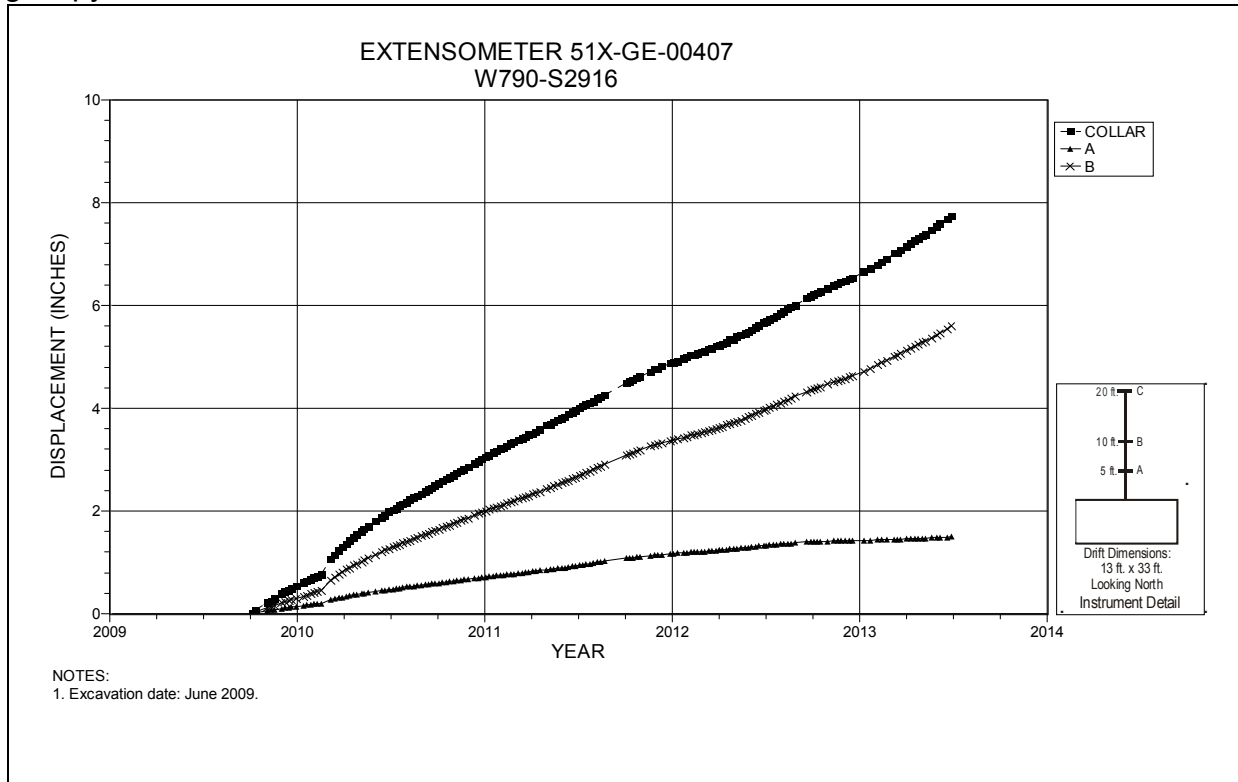

Figure 5-28 Extensometer 51X-GE-00407
Room 4, Panel 6 at W790 S2916 – Room Center – Roof

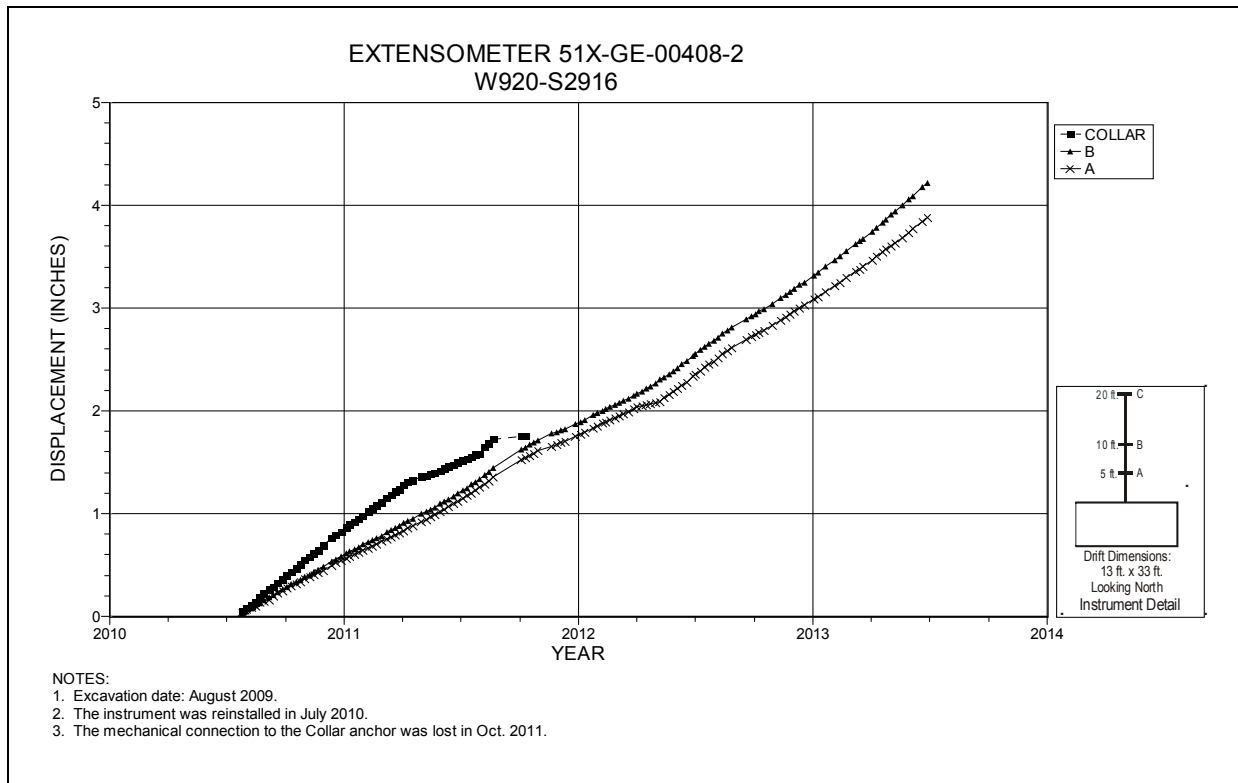

Figure 5-29 Extensometer 51X-GE-00408-2
Room 5, Panel 6 at W920 S2916 – Room Center – Roof

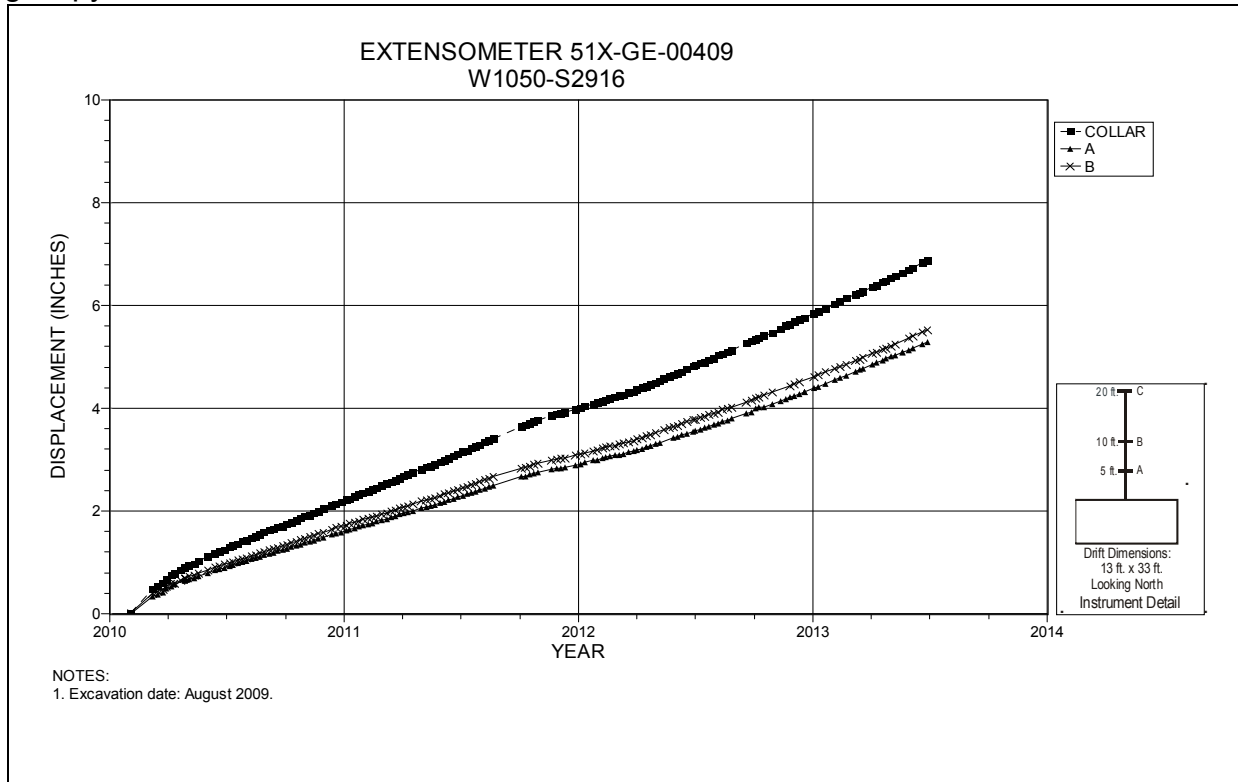

Figure 5-30 Extensometer 51X-GE-00409
Room 6, Panel 6 at W1050 S2916 – Room Center – Roof

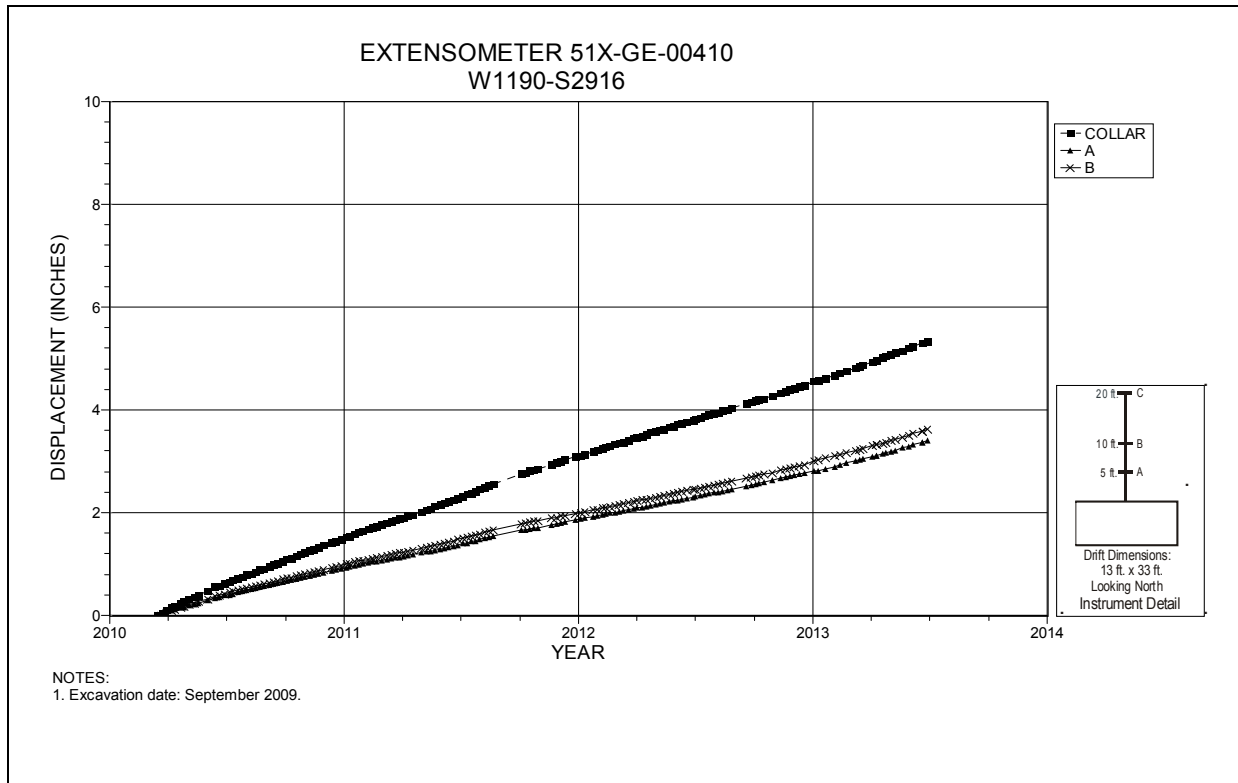

Figure 5-31 Extensometer 51X-GE-00410
Room 7, Panel 6 at W1190 S2916 – Room Center – Roof

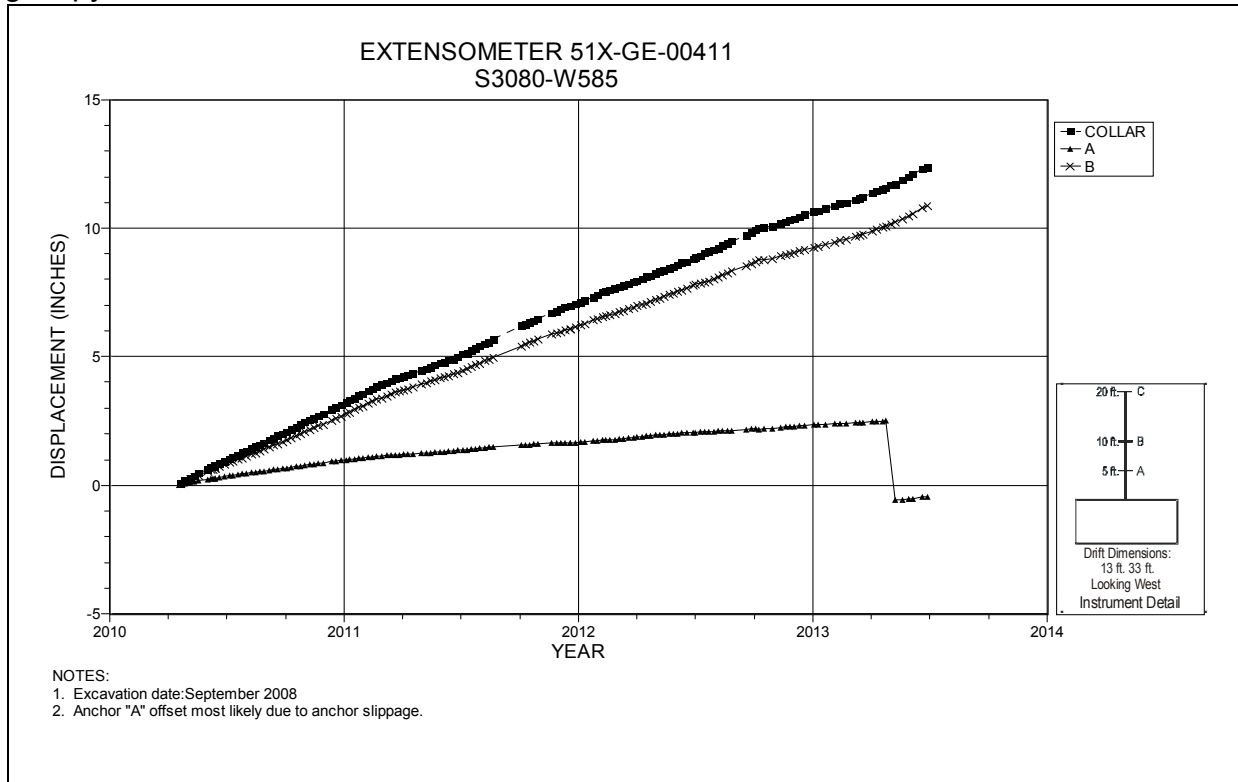

Figure 5-32 Extensometer 51X-GE-00411
S3080 W585 – Roof

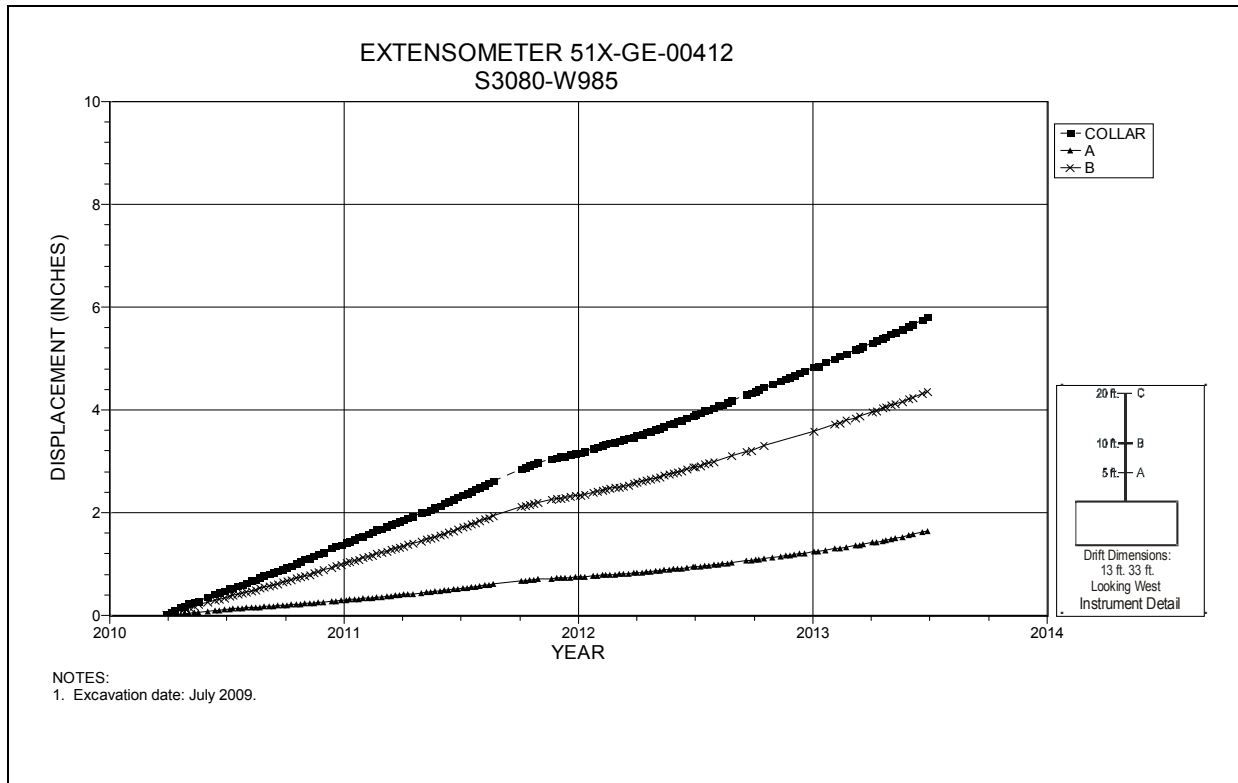

Figure 5-33 Extensometer 51X-GE-00412
S3080 W985 – Roof

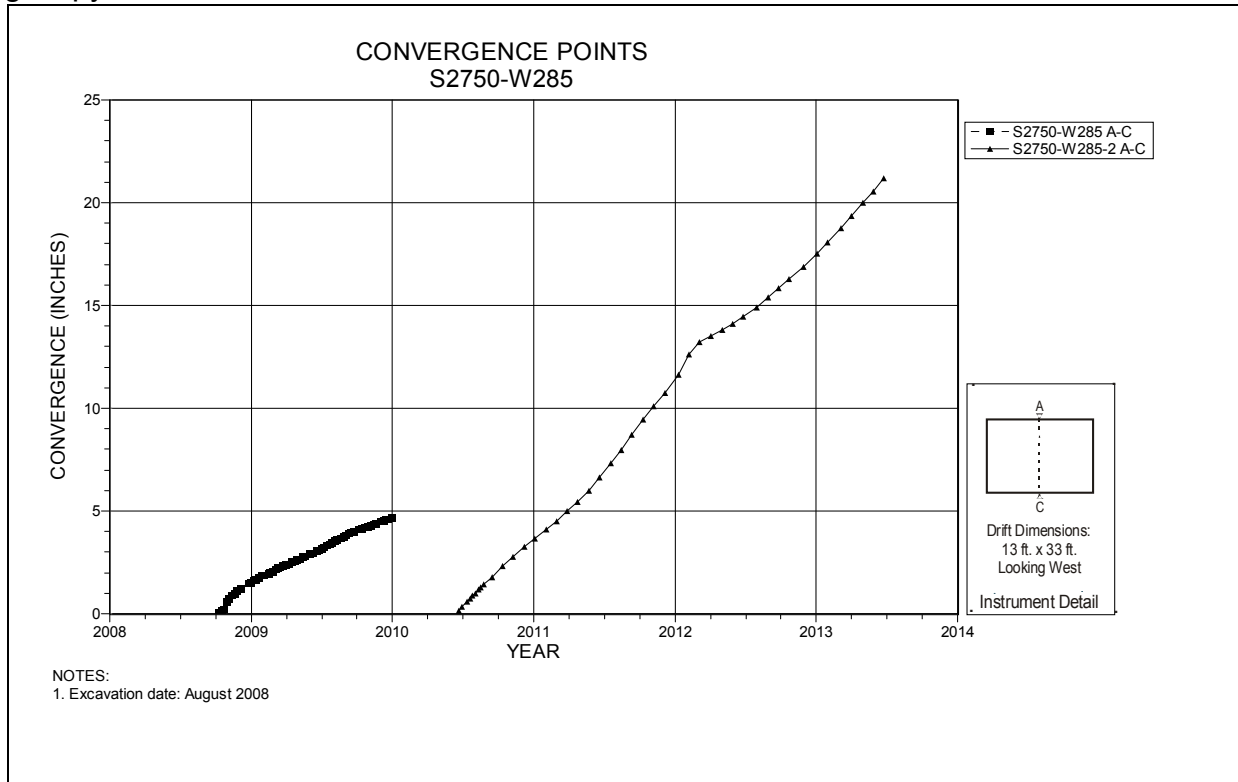

Figure 5-34 Convergence Point Array
S2750 W285 – Roof to Floor

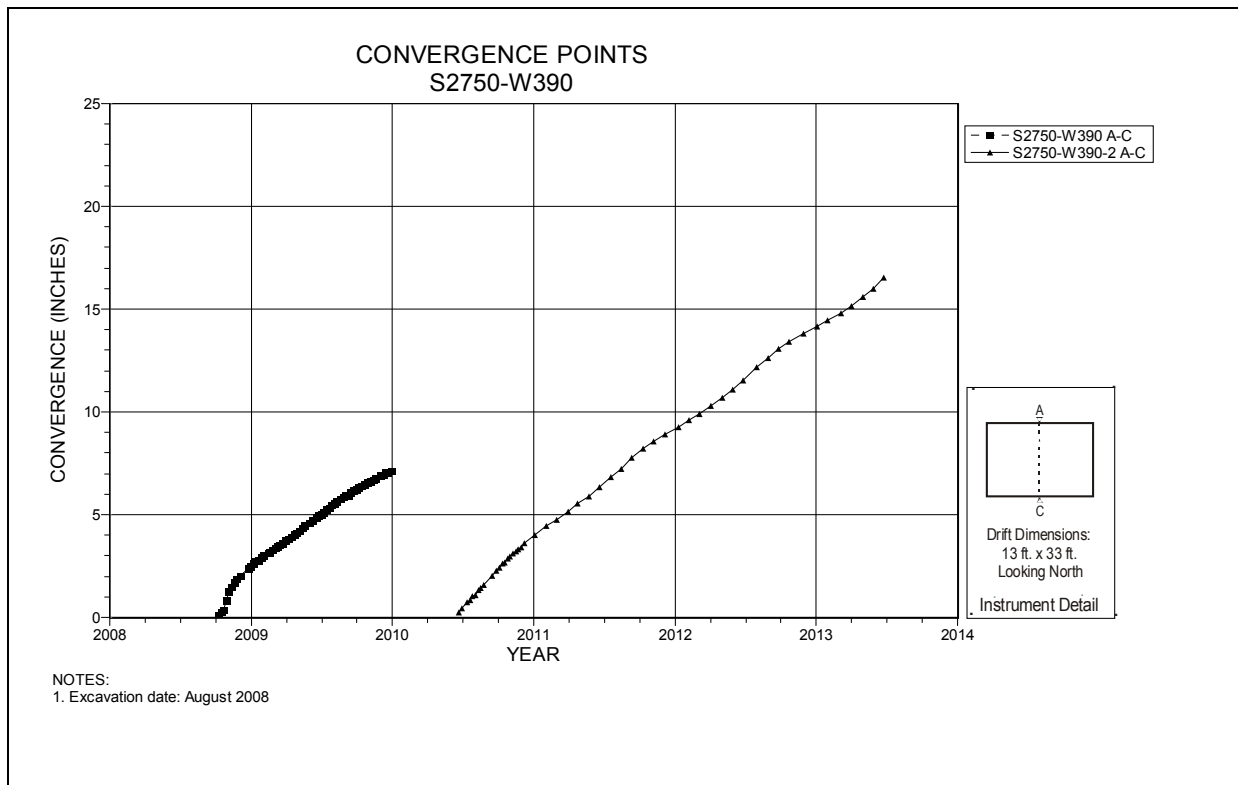
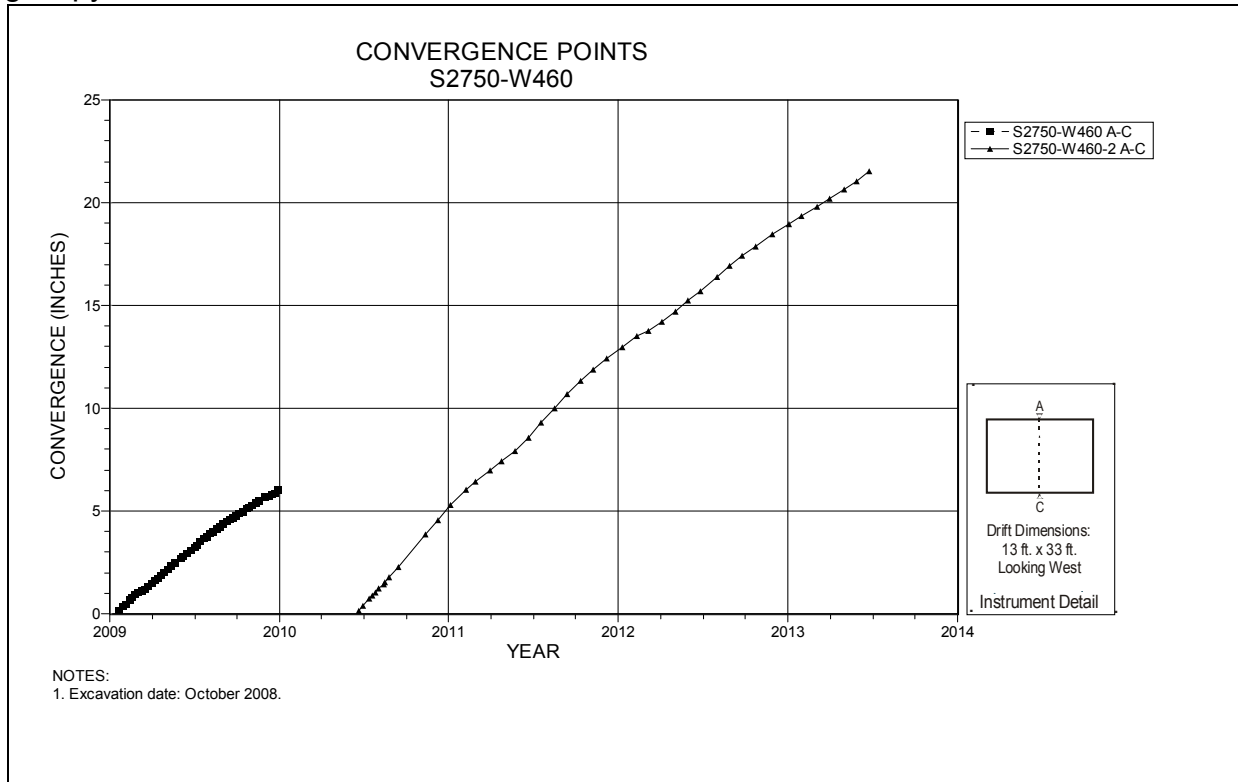
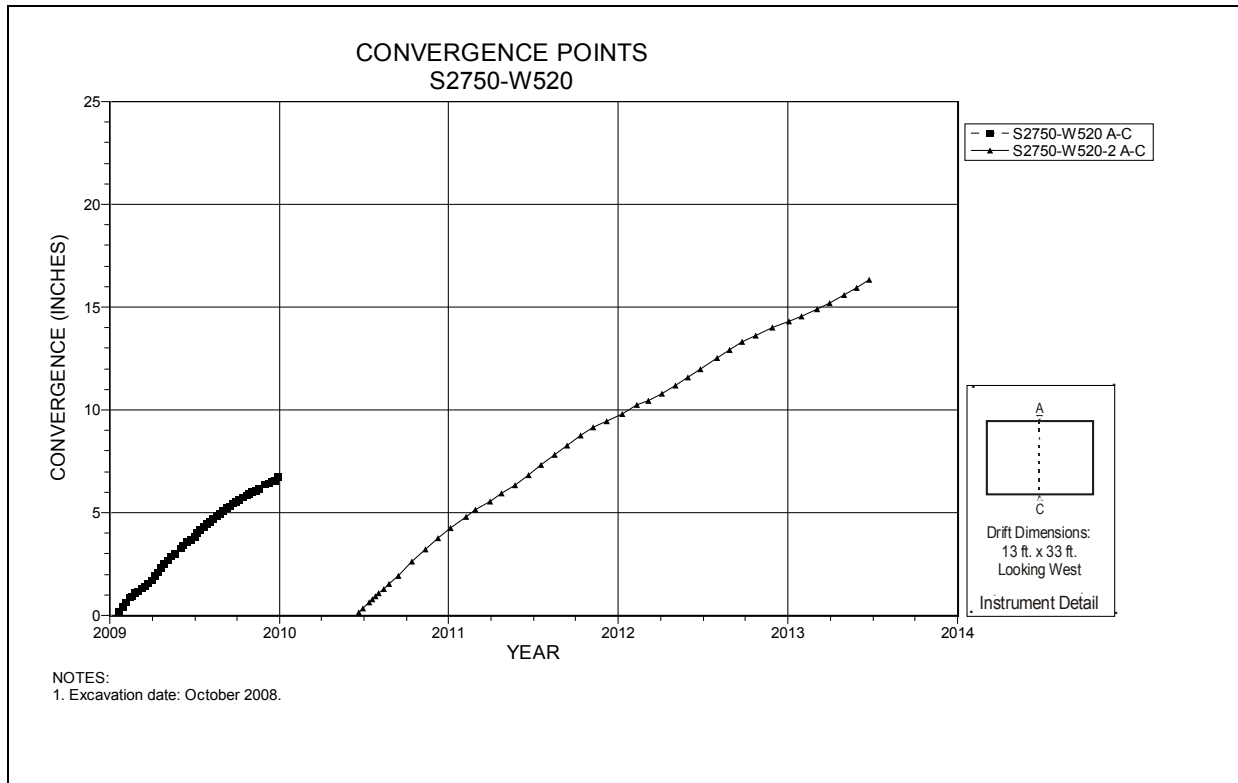

Figure 5-35 Convergence Point Array
S2750 W390 Intersection (Room 1, Panel 6) – Roof to Floor



**Figure 5-36 Convergence Point Array
S2750 W460 – Roof to Floor**



**Figure 5-37 Convergence Point Array
S2750 W520 Intersection (Room 2, Panel 6) – Roof to Floor**

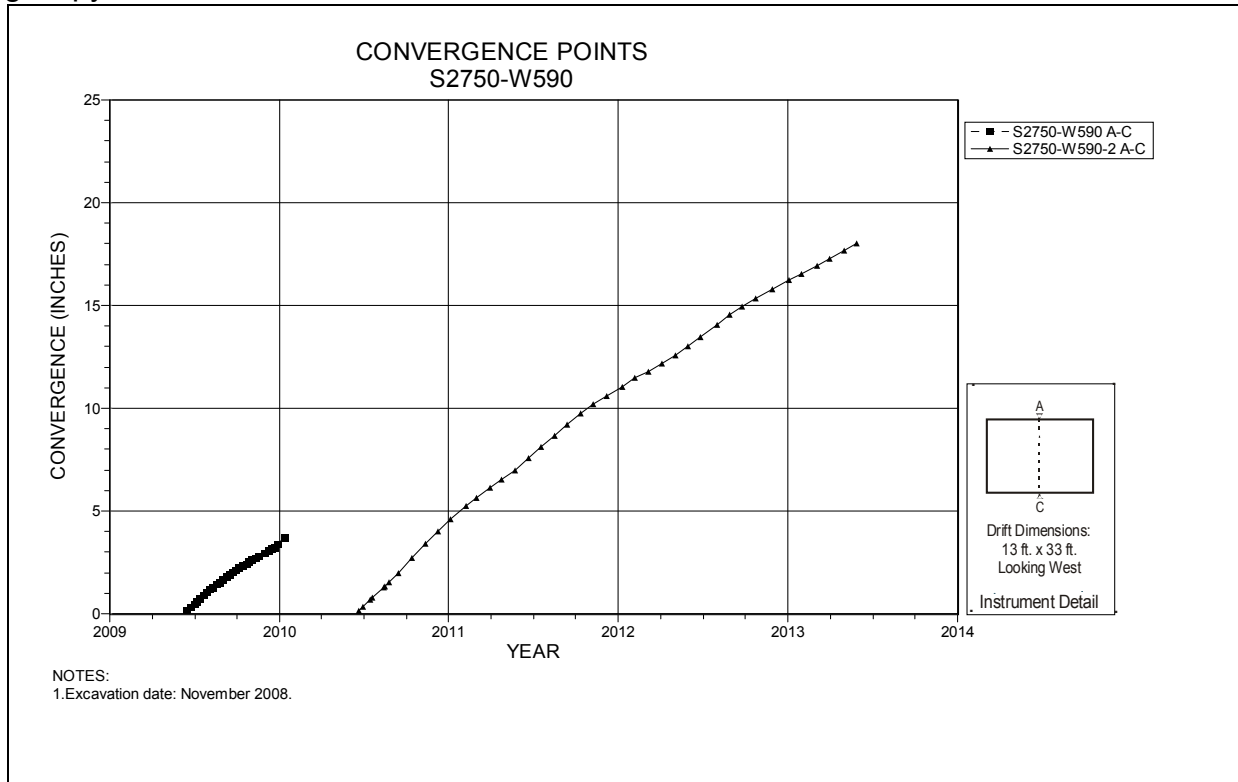

**Figure 5-38 Convergence Point Array
S2750 W590 – Roof to Floor**

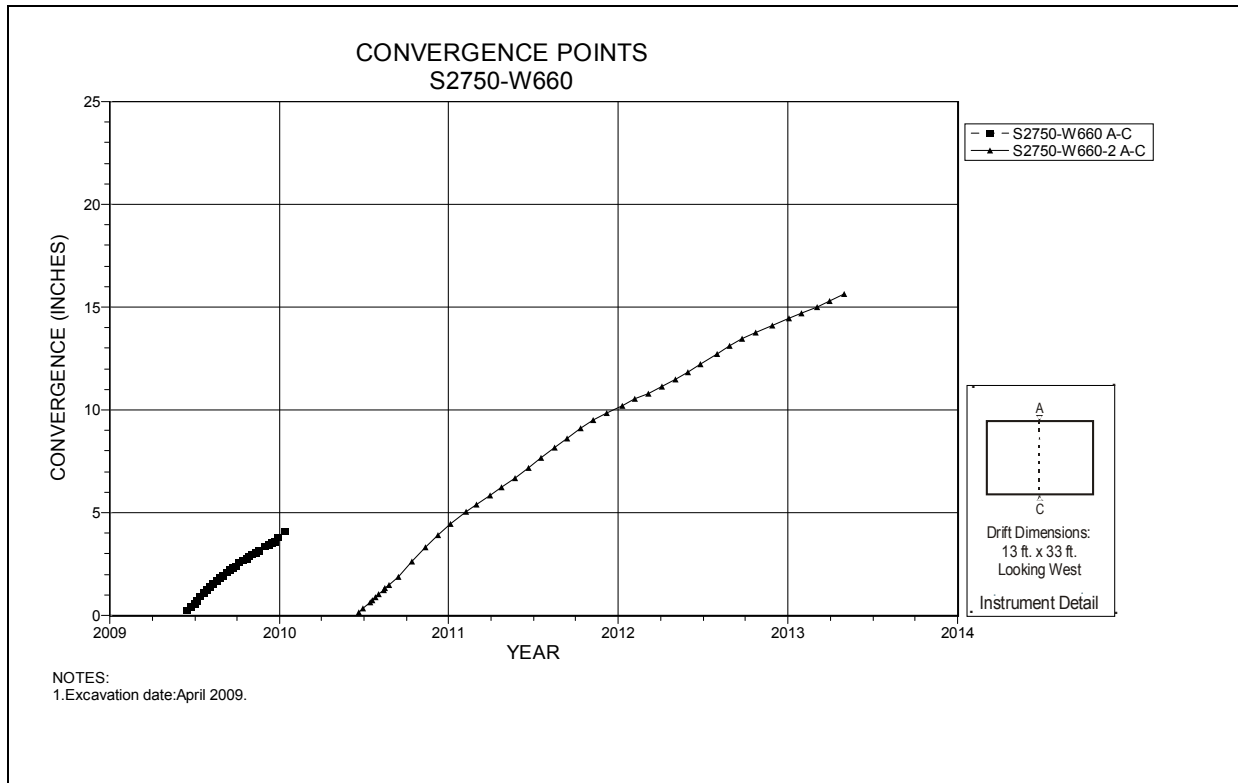

**Figure 5-39 Convergence Point Array
S2750 W660 Intersection (Room 3, Panel 6) – Roof to Floor**

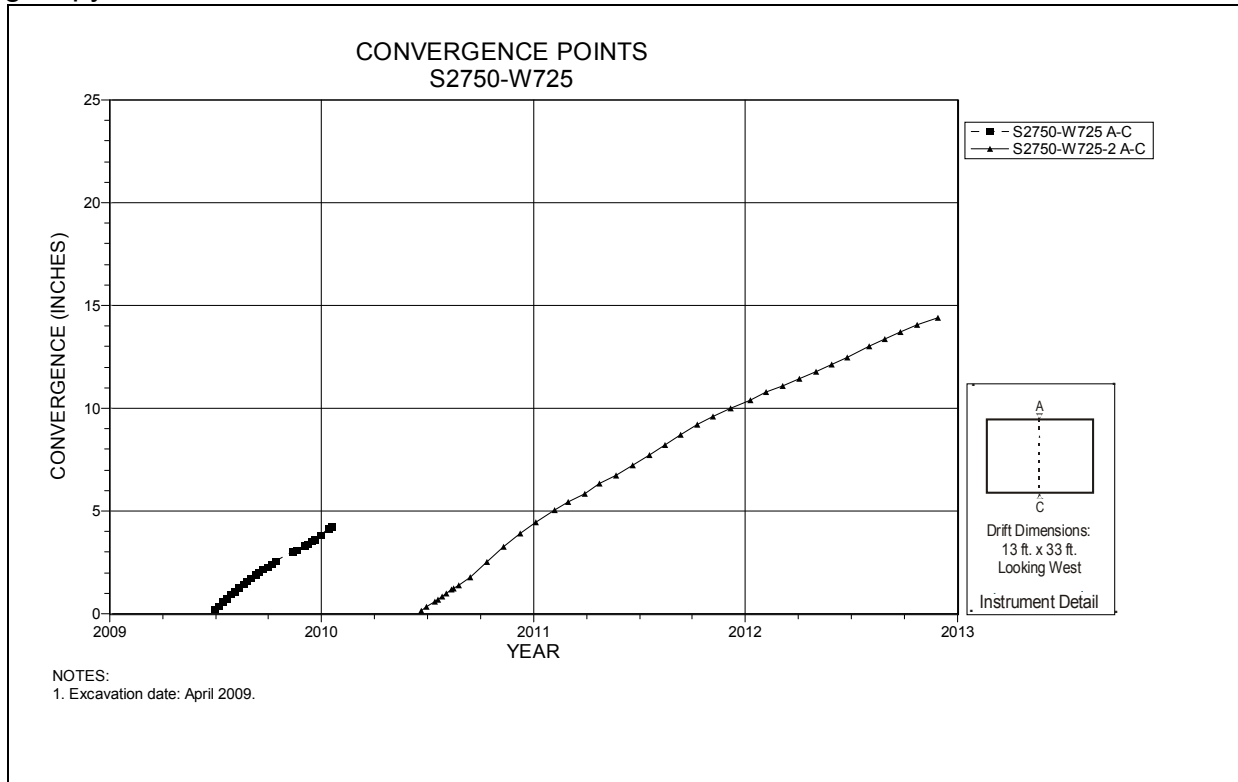

**Figure 5-40 Convergence Point Array
S2750 W725 – Roof to Floor**

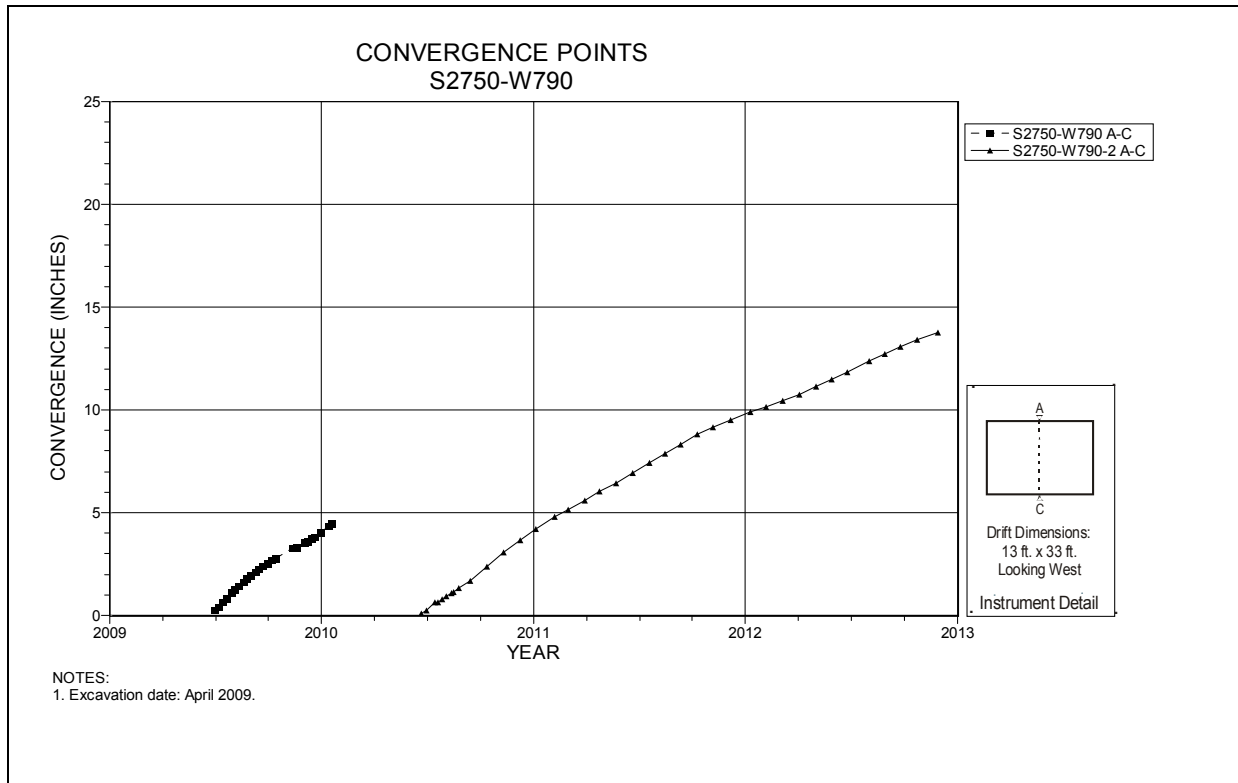

**Figure 5-41 Convergence Point Array
S2750 W790 Intersection (Room 4, Panel 6) – Roof to Floor**

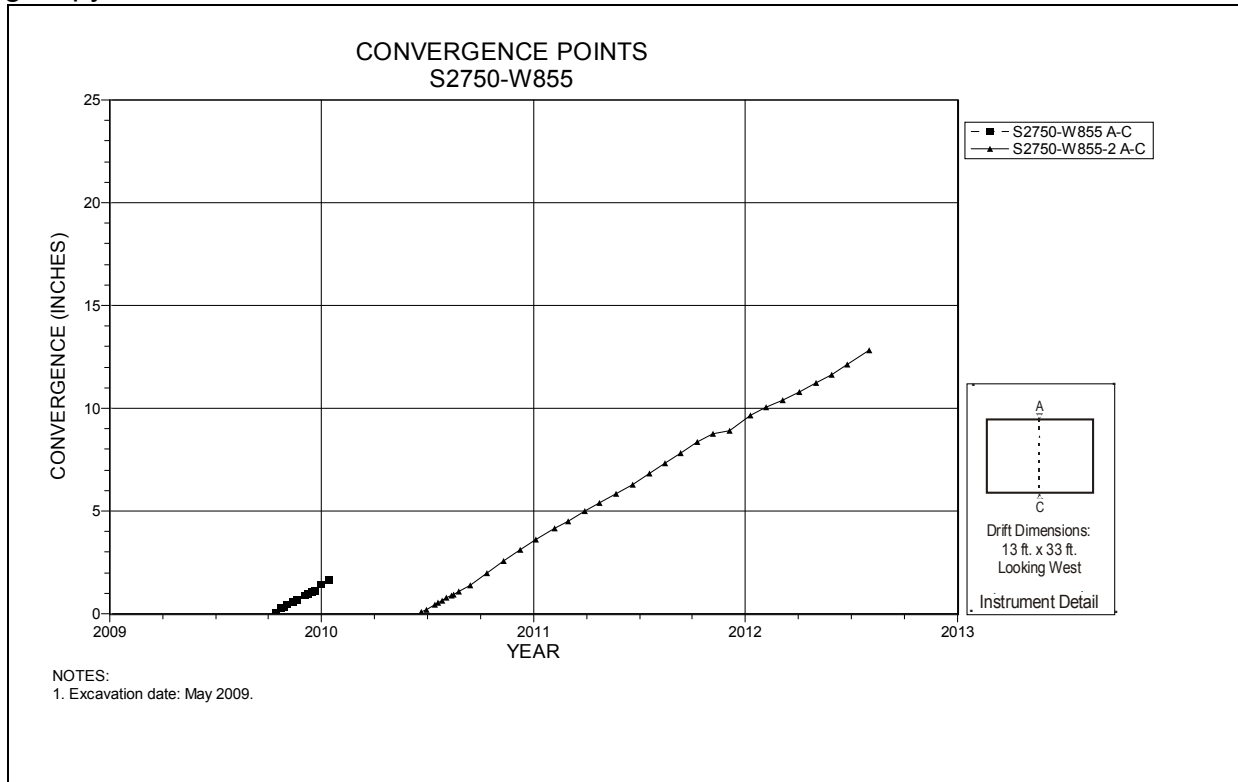

**Figure 5-42 Convergence Point Array
S2750 W885 – Roof to Floor**

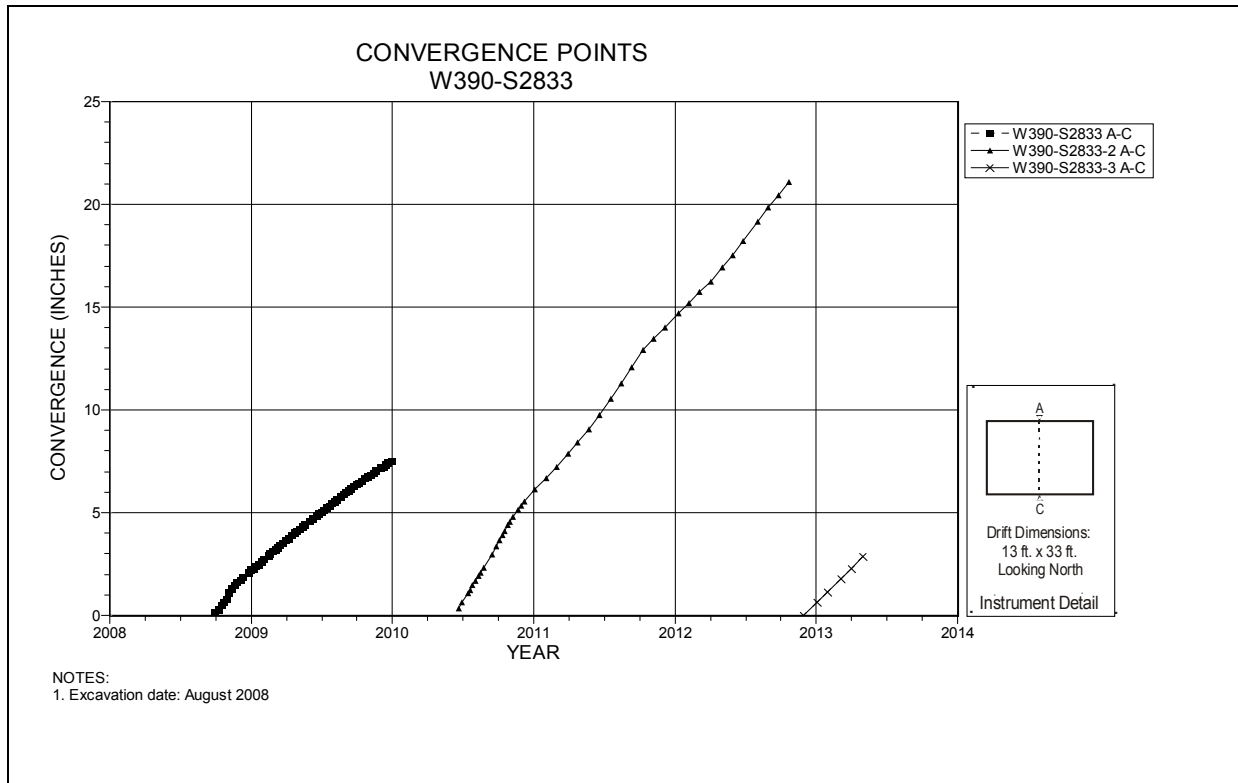

**Figure 5-43 Convergence Point Array
Room 1, Panel 6 at W390 S2833 – Roof to Floor**

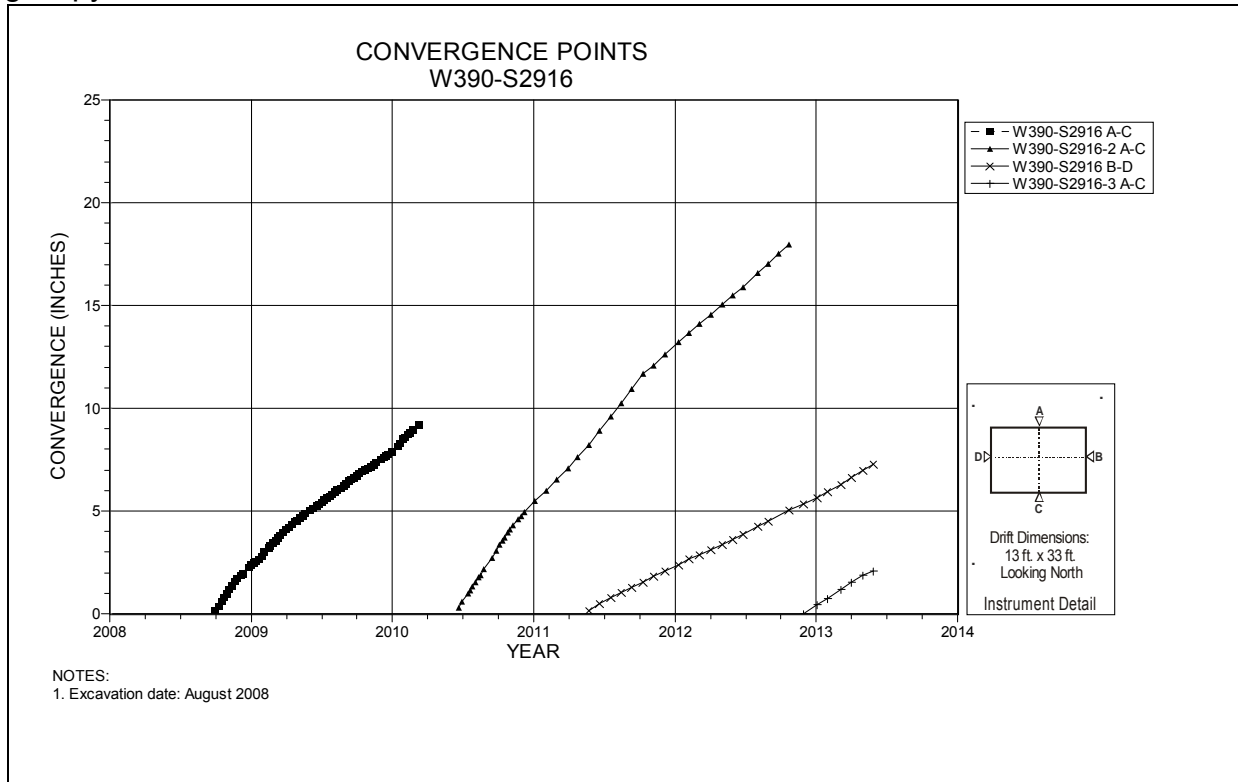

**Figure 5-44 Convergence Point Array
Room 1, Panel 6 at W390 S2916 – Room Center – All Chords**

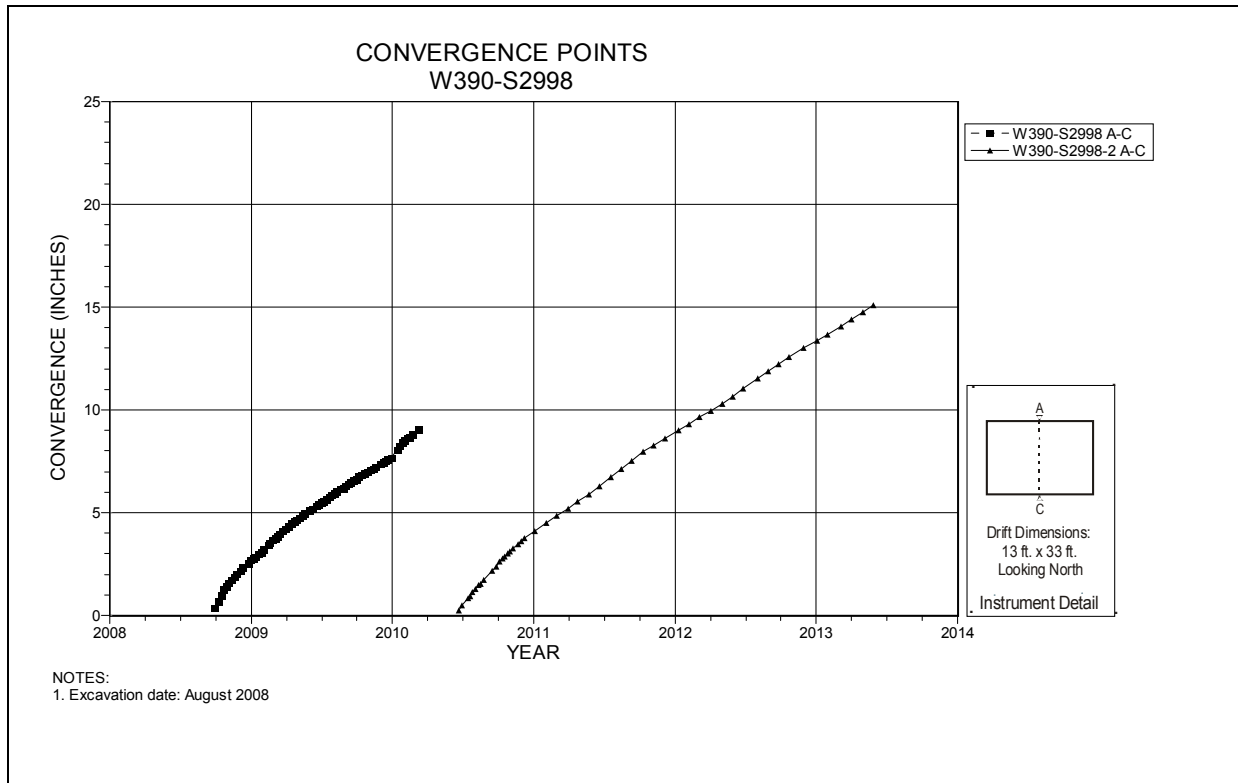

**Figure 5-45 Convergence Point Array
Room 1, Panel 6 at W390 S2998 – Roof to Floor**

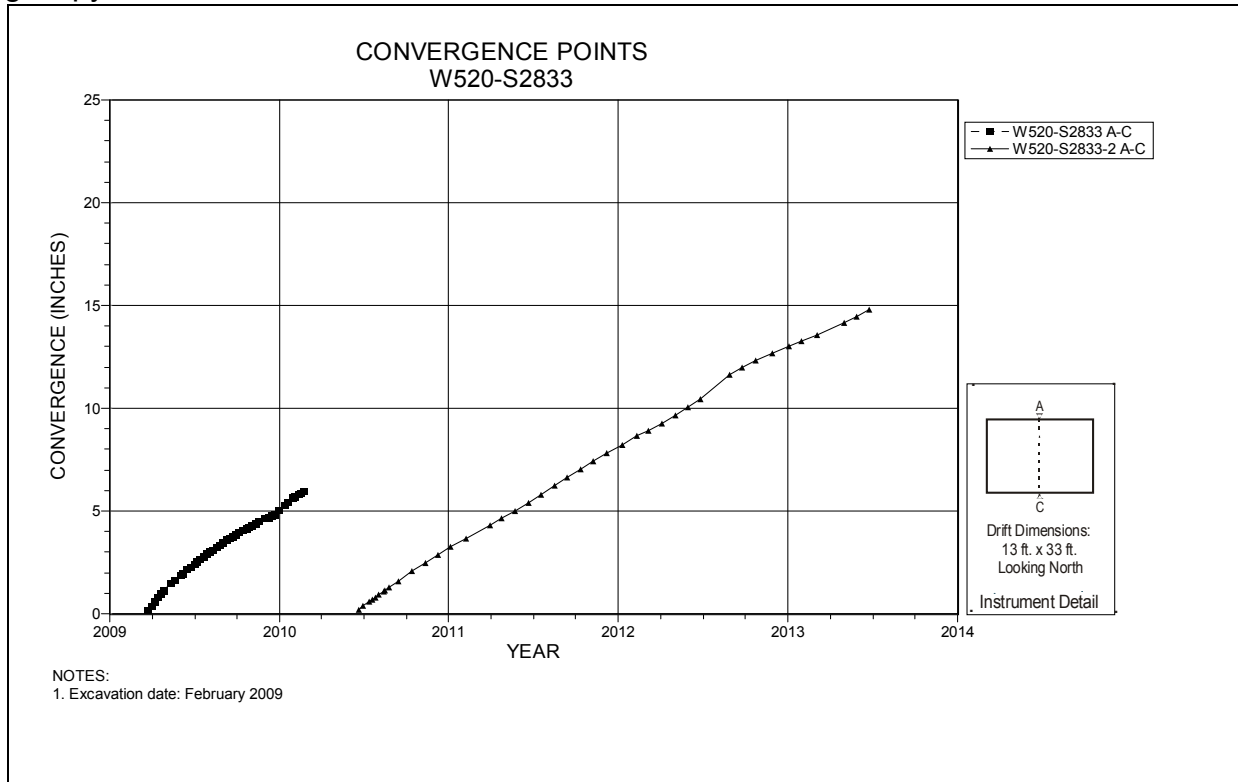

**Figure 5-46 Convergence Point Array
Room 2, Panel 6 at W520 S2833 – Roof to Floor**

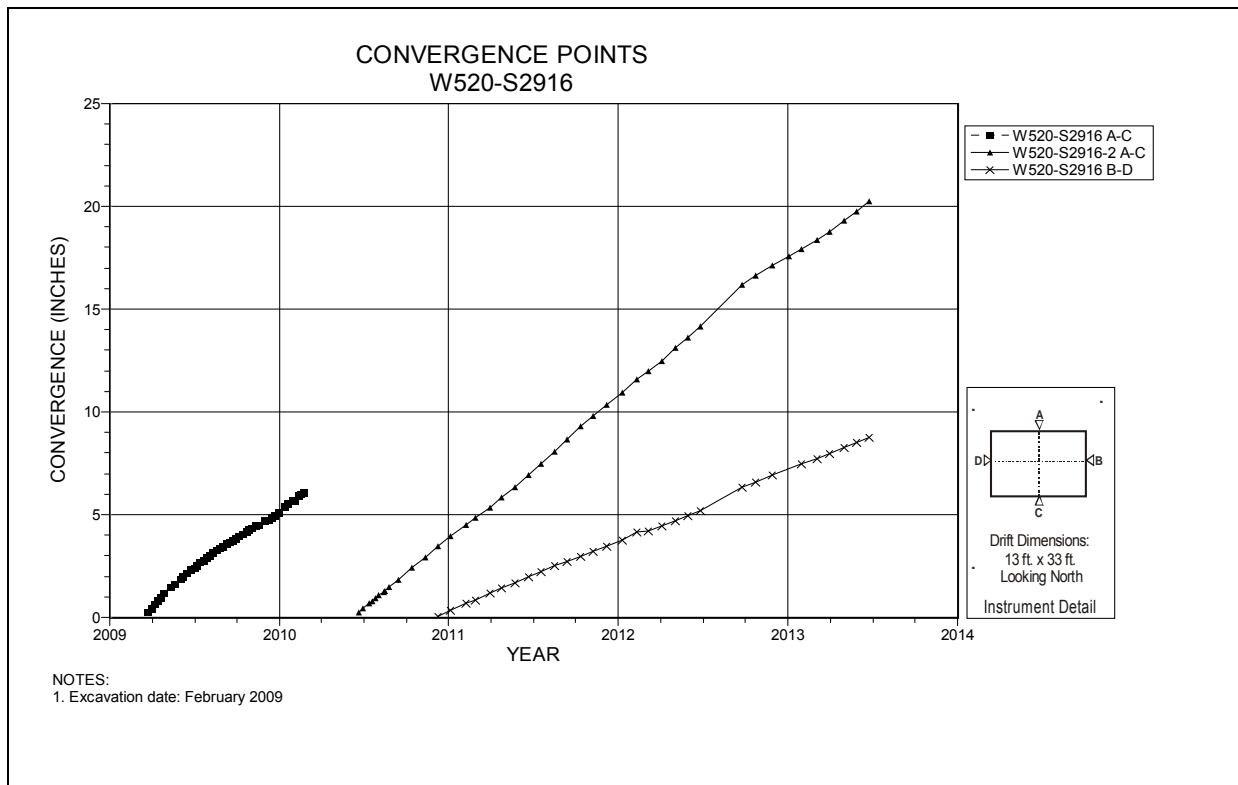

**Figure 5-47 Convergence Point Array
Room 2, Panel 6 at W520 S2916 – Room Center – All Chords**

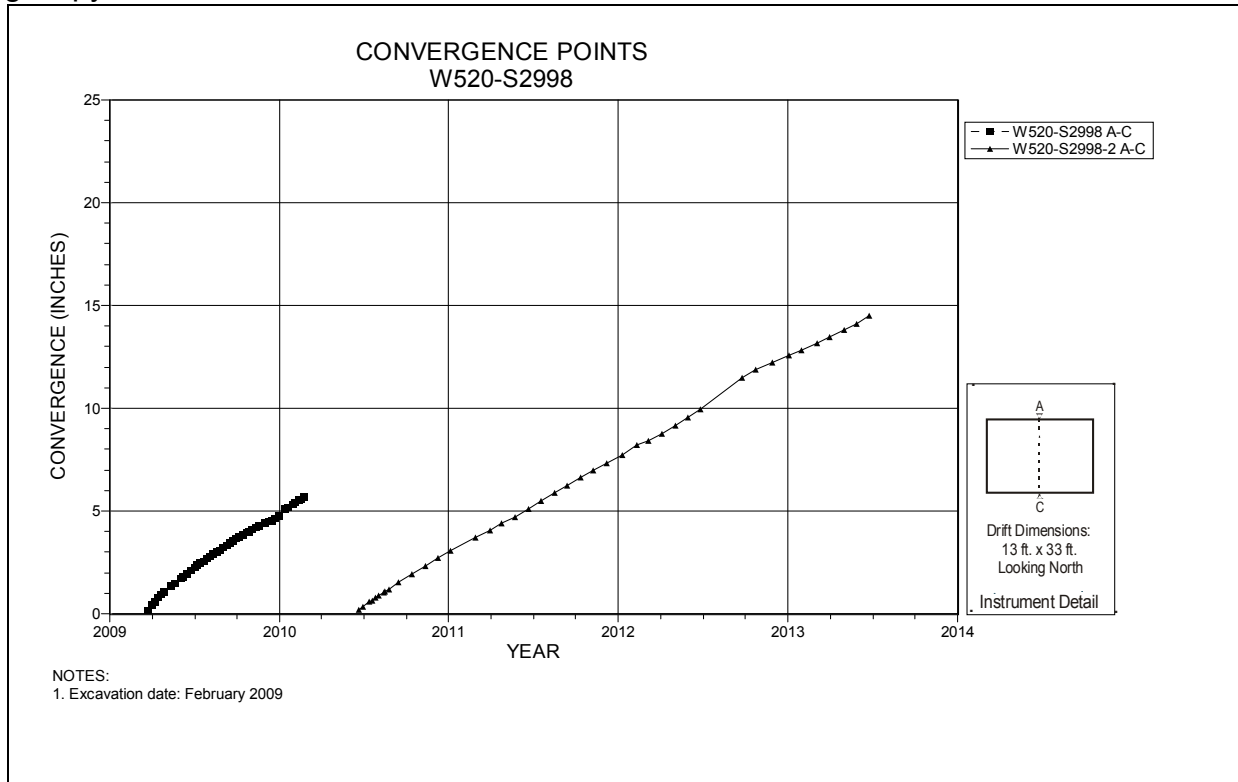

Figure 5-48 Convergence Point Array
Room 2, Panel 6 at W520 S2998 – Roof to Floor

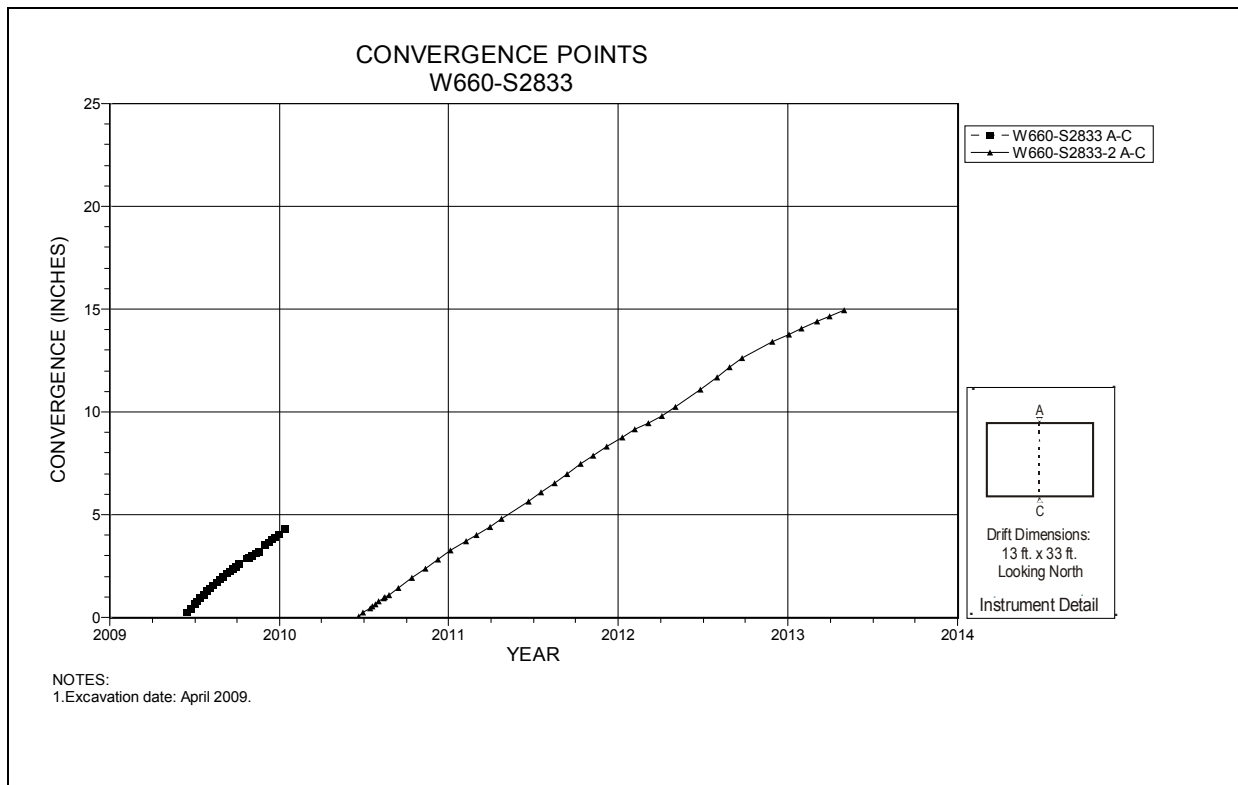

Figure 5-49 Convergence Point Array
Room 3, Panel 6 at W660 S2833 – Roof to Floor

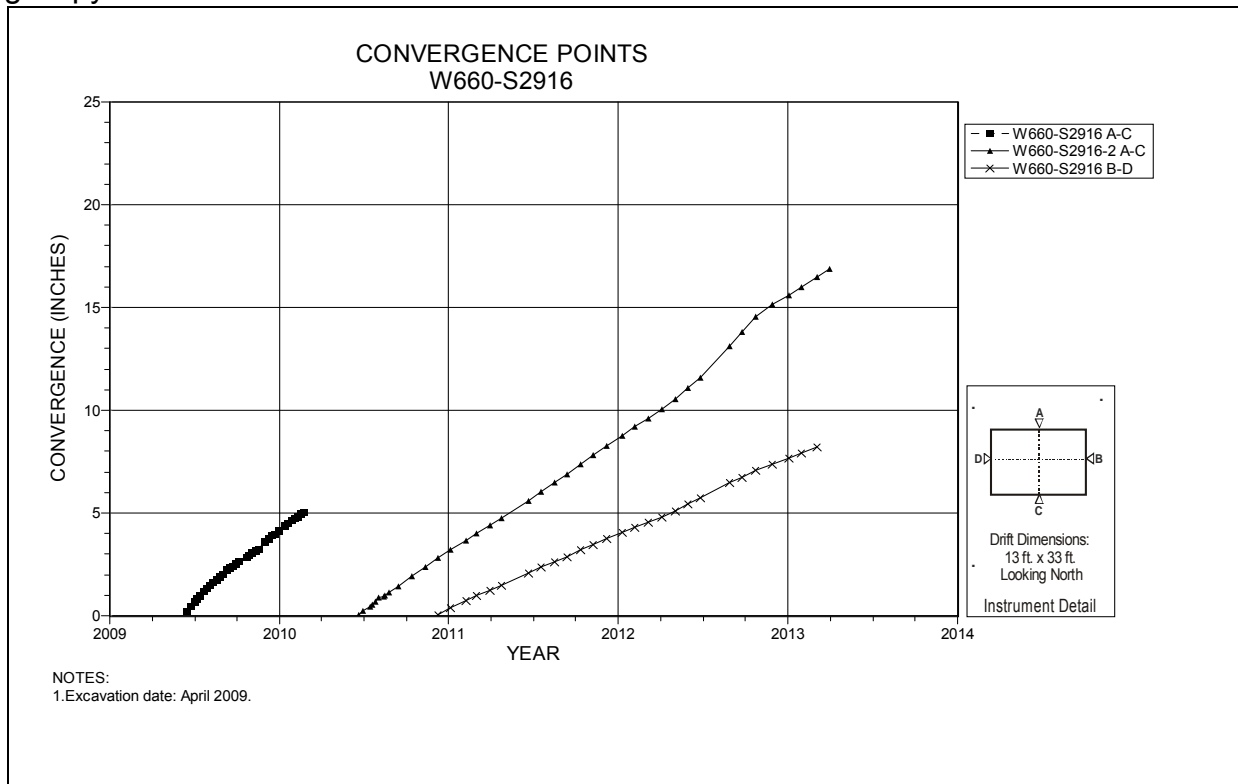

Figure 5-50 Convergence Point Array
Room 3, Panel 6 at W660 S2916 – Room Center – All Chords

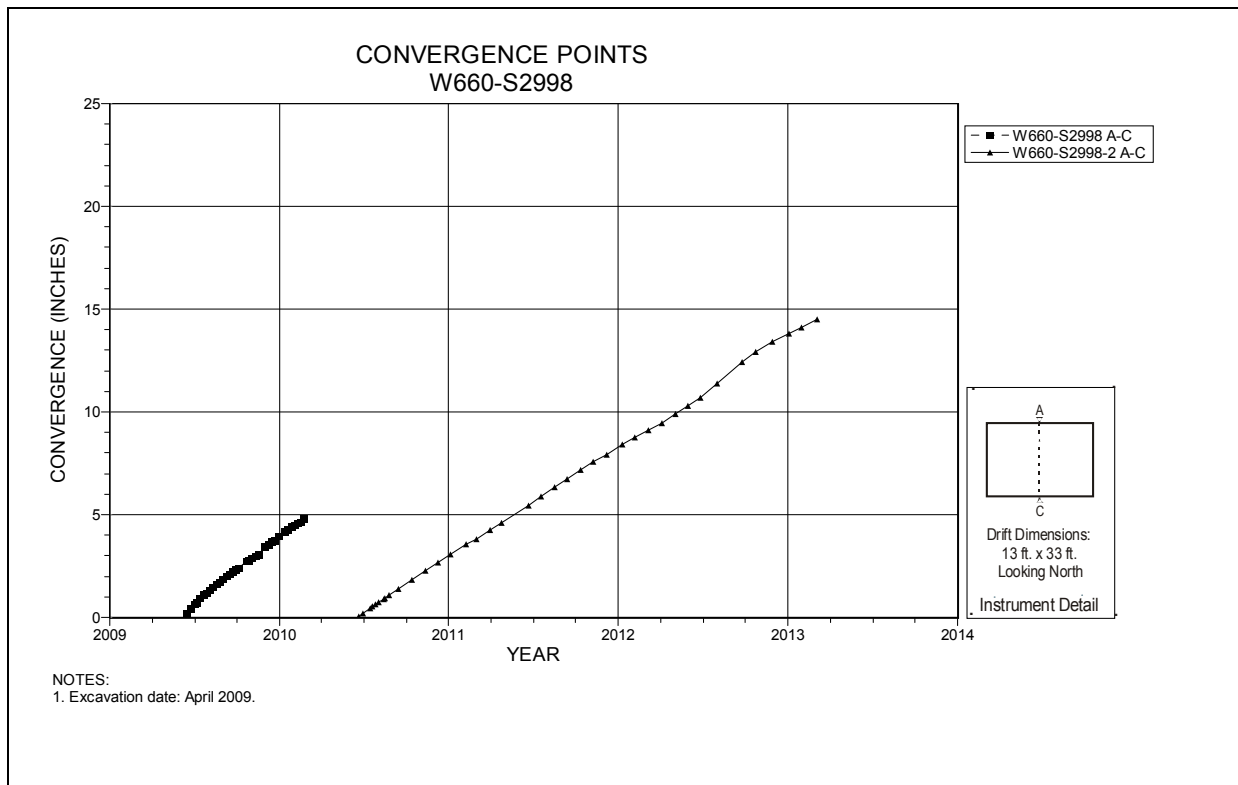
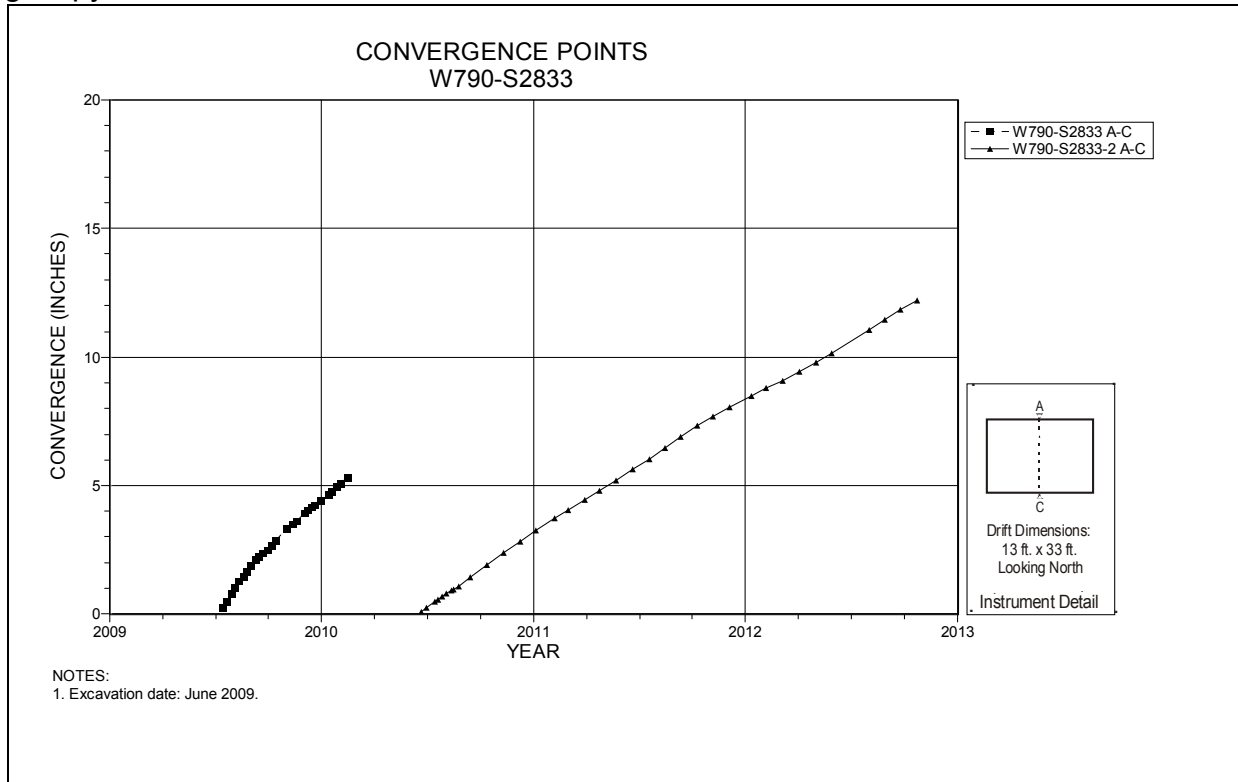
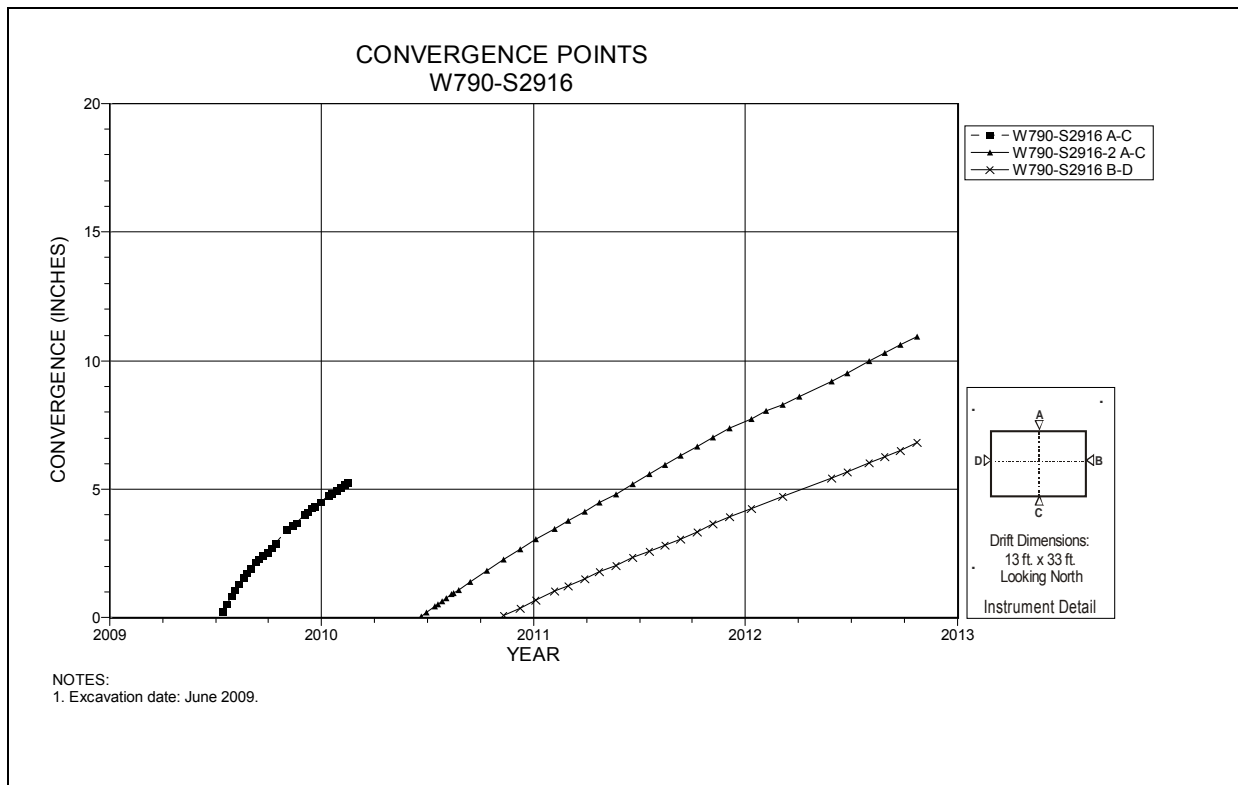

Figure 5-51 Convergence Point Array
Room 3, Panel 6 at W660 S2998 – Roof to Floor



**Figure 5-52 Convergence Point Array
Room 4, Panel 6 at W790 S2833 – Roof to Floor**



**Figure 5-53 Convergence Point Array
Room 4, Panel 6 at W790 S2916 – Room Center – All Chords**

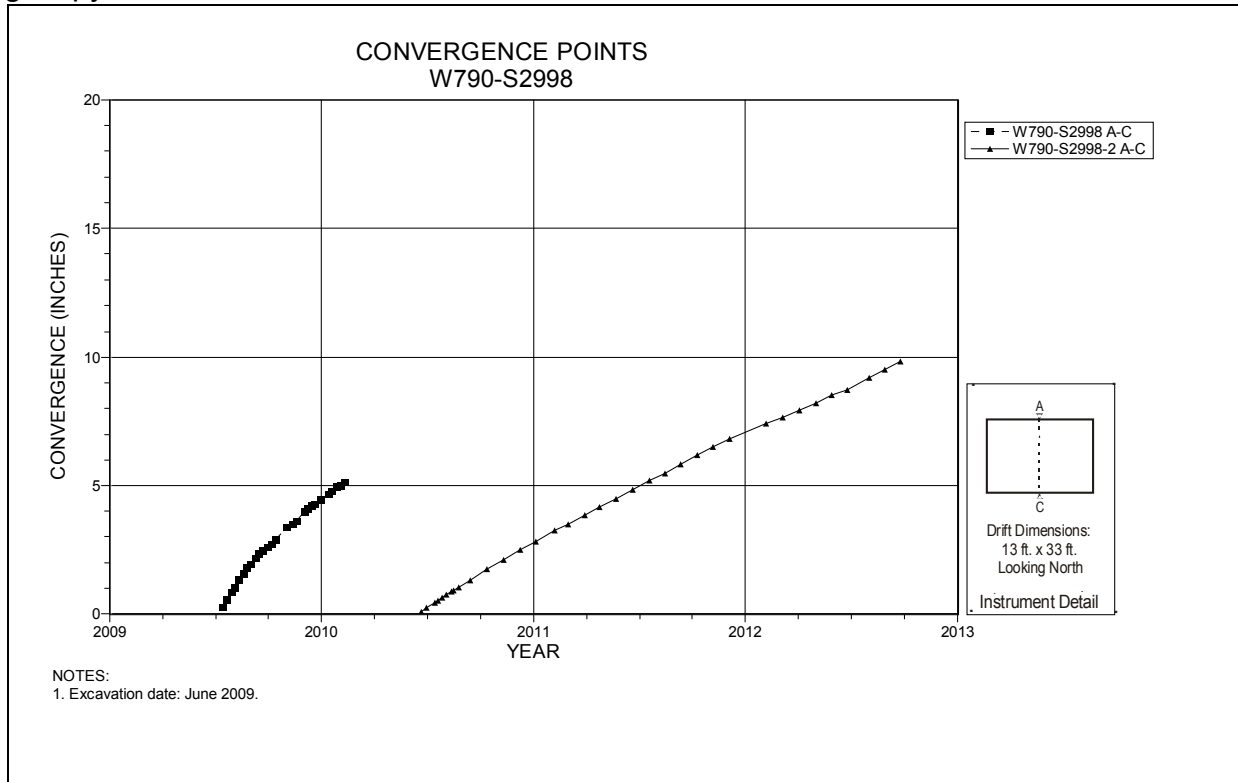

Figure 5-54 Convergence Point Array
Room 4, Panel 6 at W790 S2998 – Roof to Floor

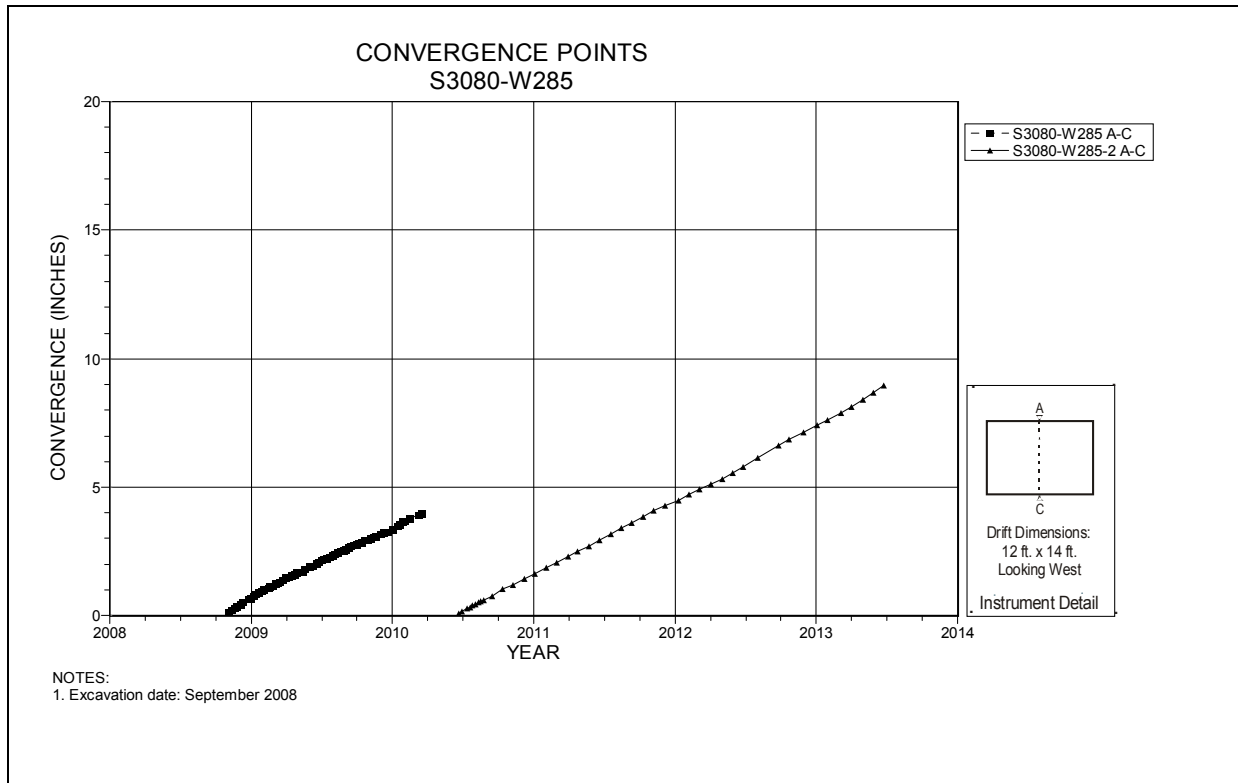
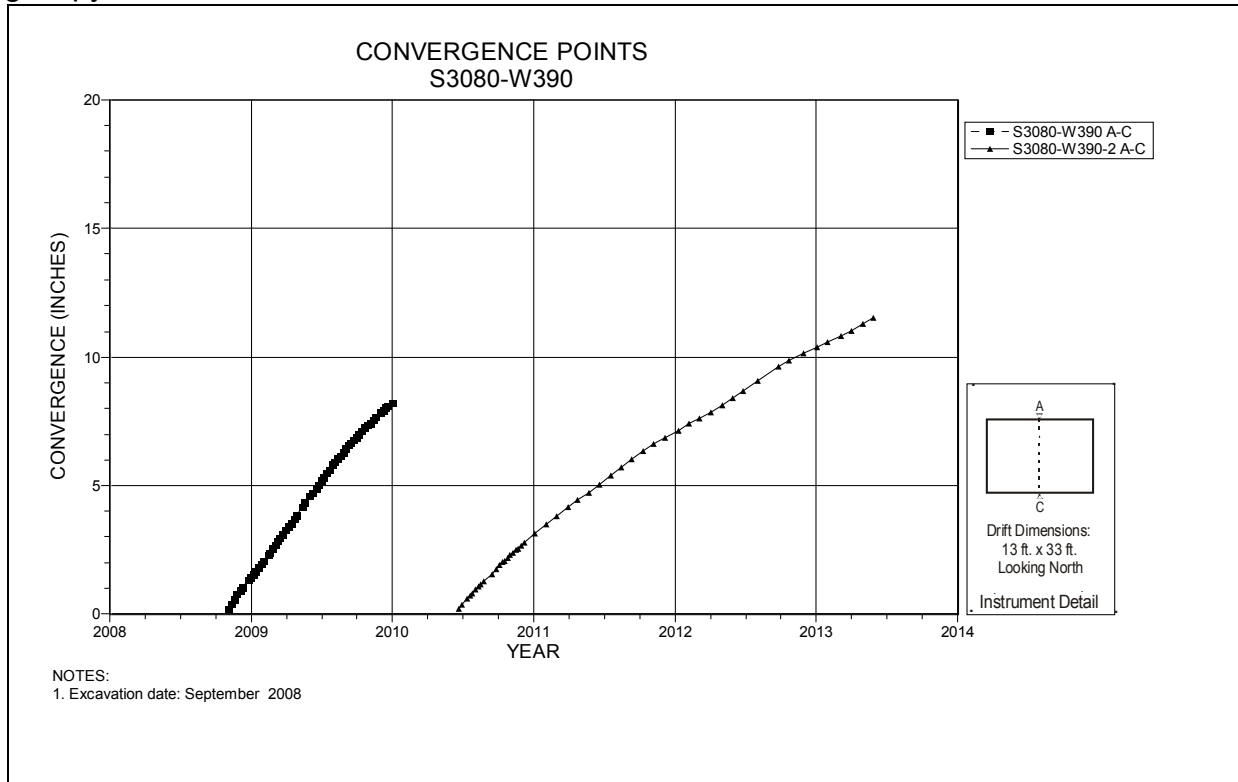
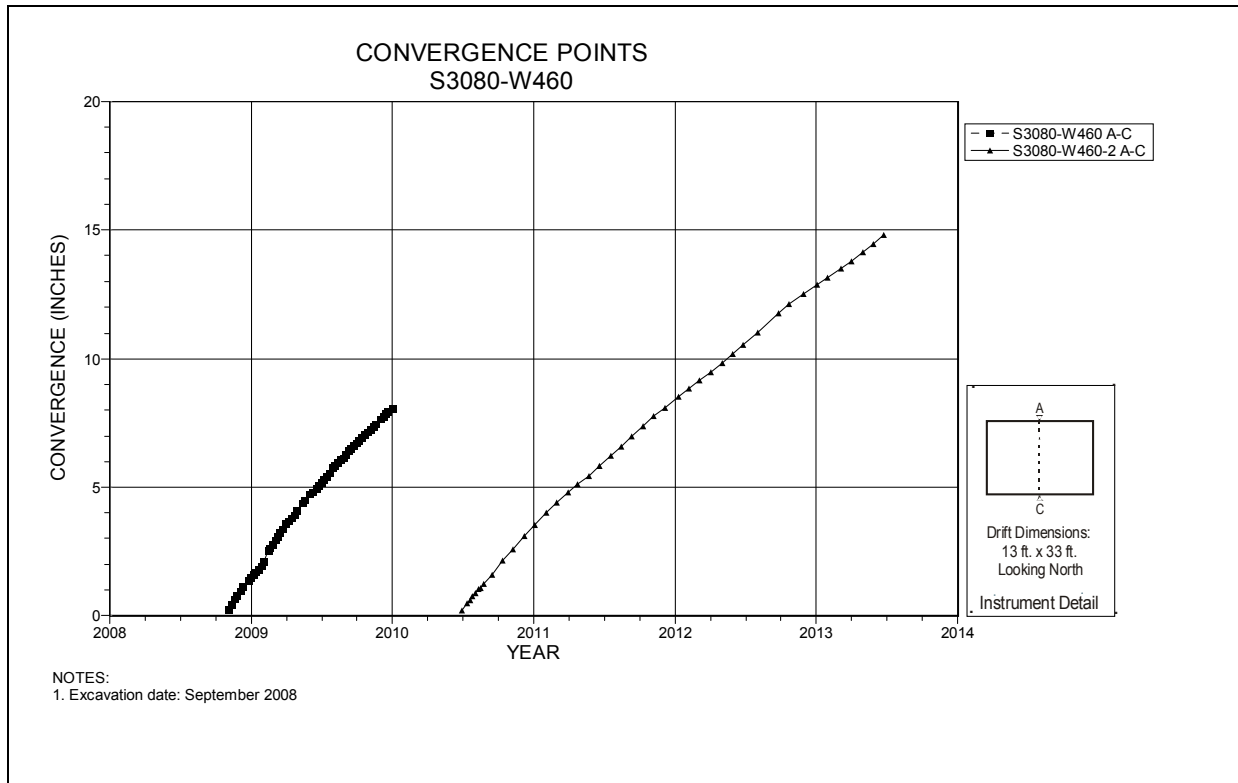

Figure 5-55 Convergence Point Array
S3080 W285 – Roof to Floor



**Figure 5-56 Convergence Point Array
S3080 W390 Intersection (Room 1, Panel 6) – Roof to Floor**



**Figure 5-57 Convergence Point Array
S3080 W460 – Roof to Floor**

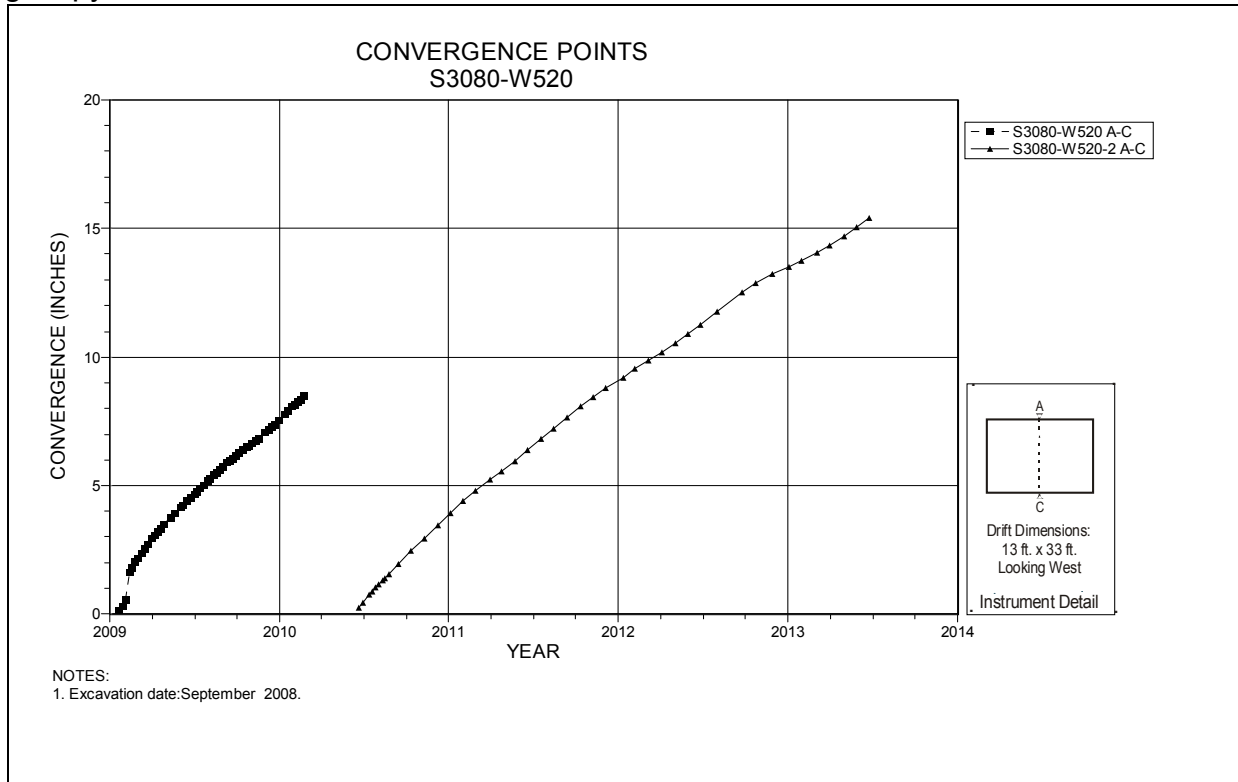

**Figure 5-58 Convergence Point Array
S3080 W520 Intersection (Room 2, Panel 6) – Roof to Floor**

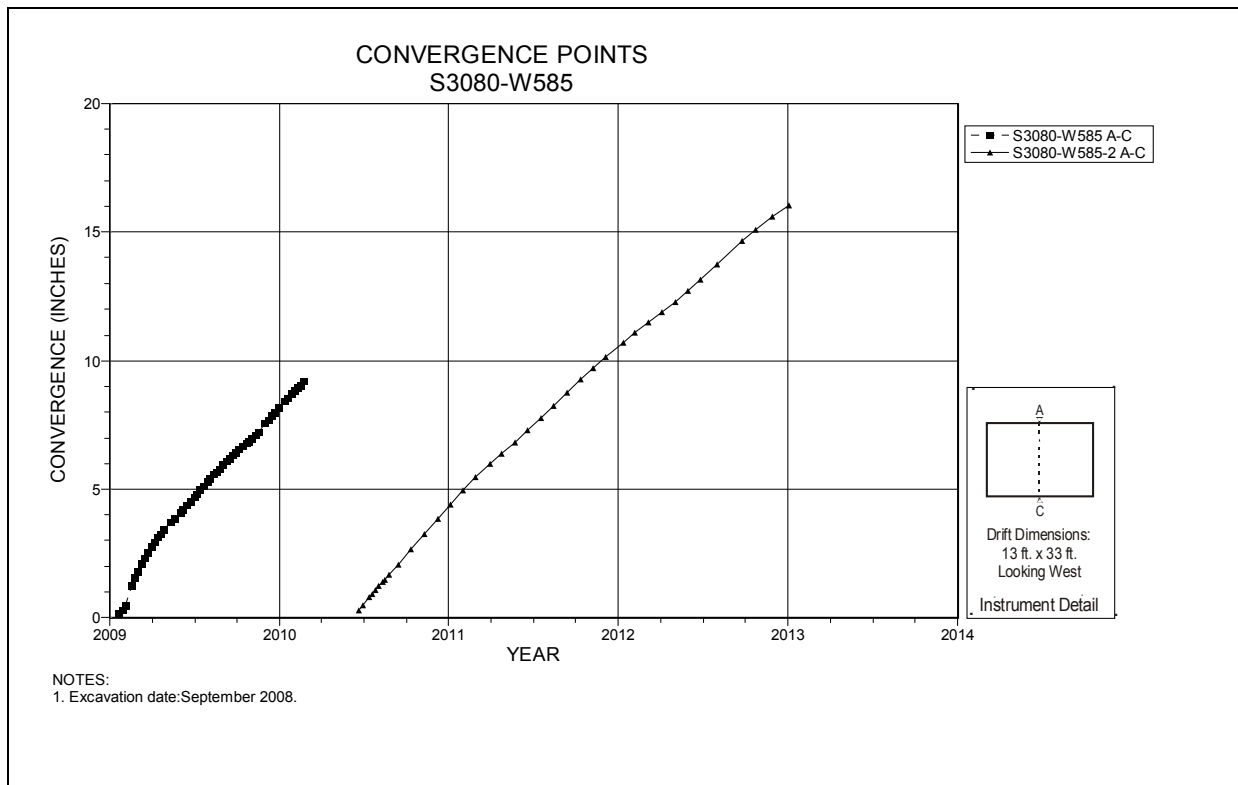

**Figure 5-59 Convergence Point Array
S3080 W585 – Roof to Floor**

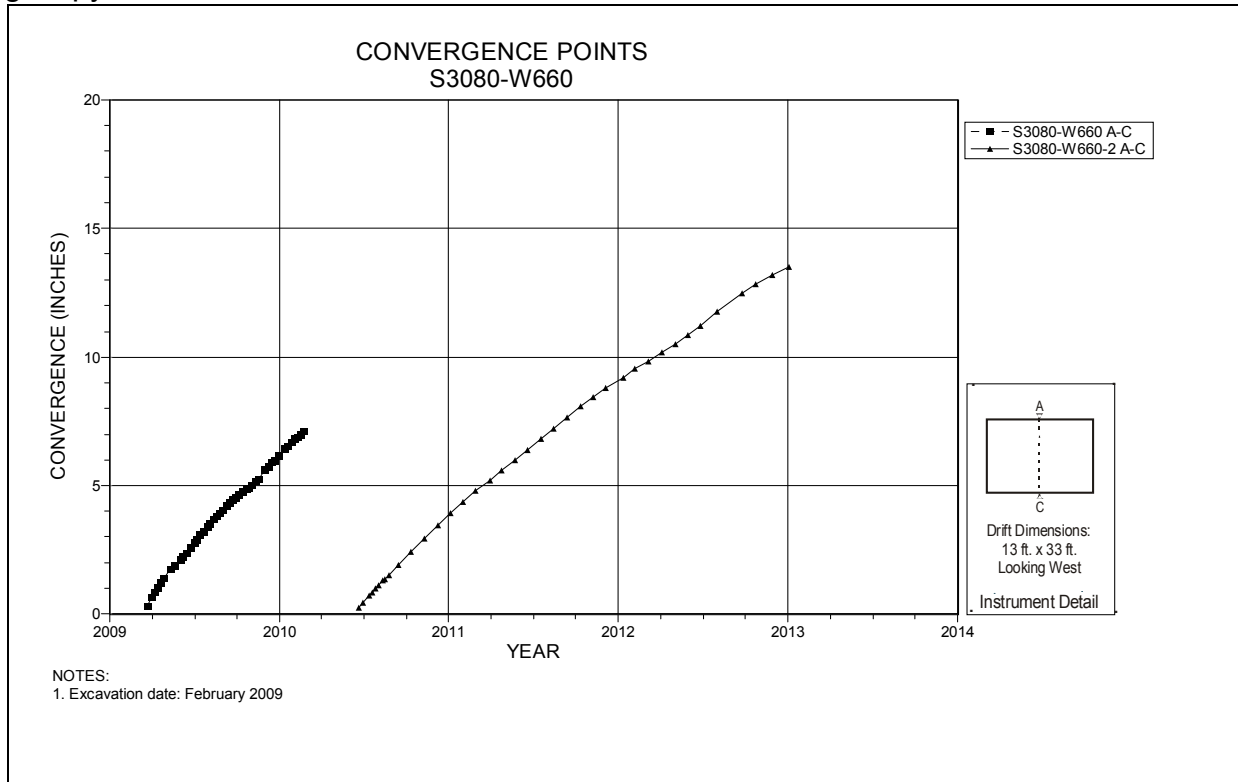

Figure 5-60 Convergence Point Array
 S3080 W660 Intersection (Room 3, Panel 6) – Roof to Floor

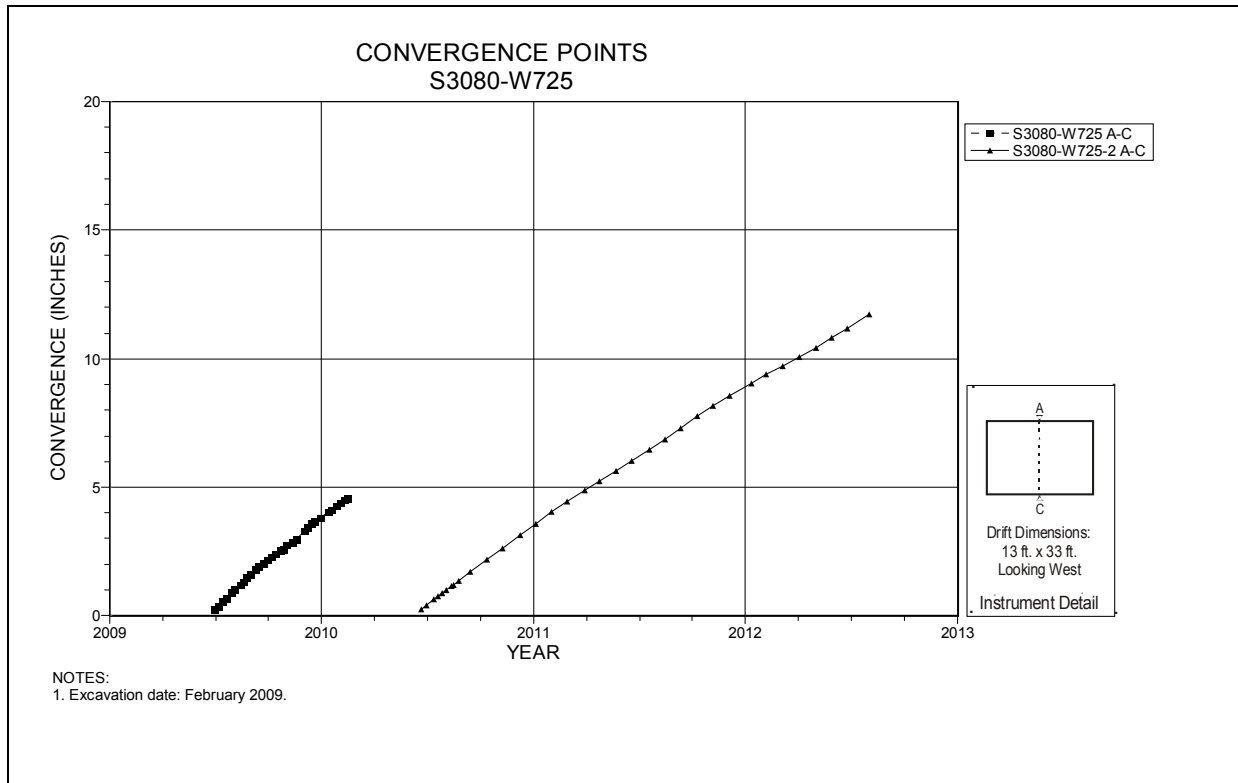

Figure 5-61 Convergence Point Array
 S3080 W725 – Roof to Floor

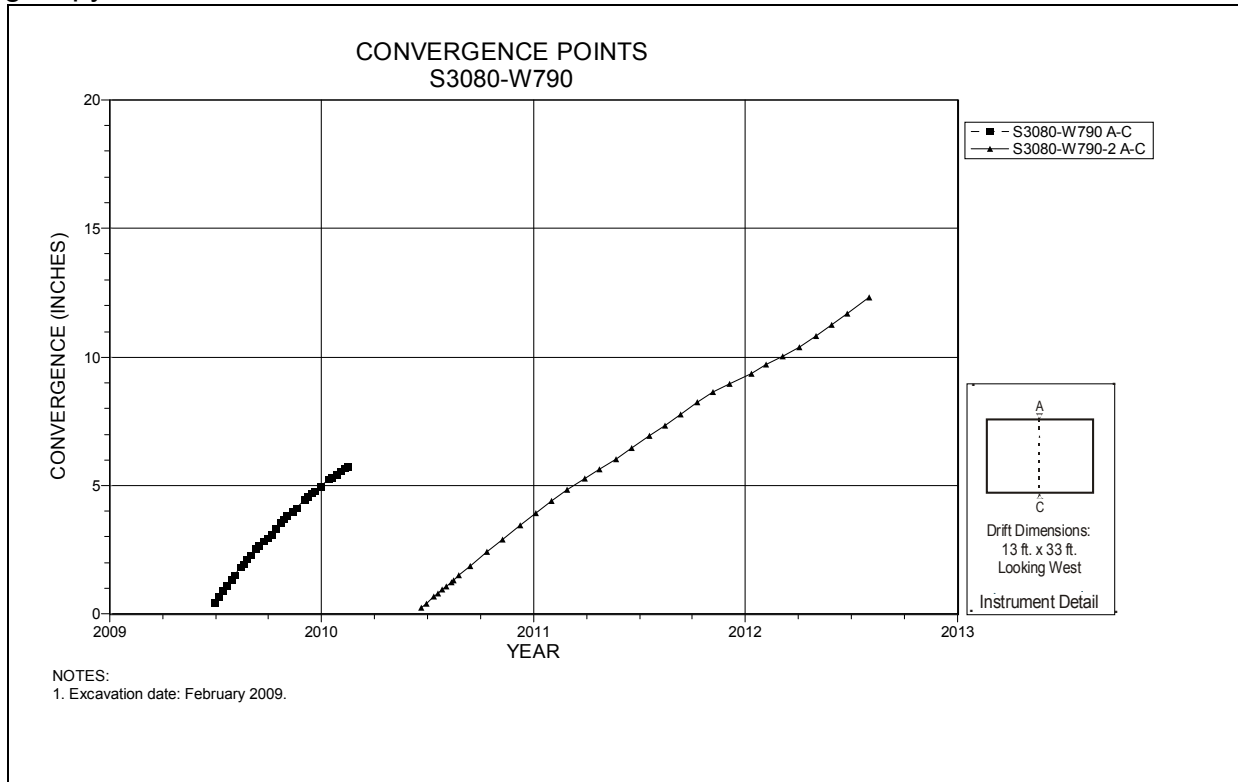

Figure 5-62 Convergence Point Array
S3080 W790 Intersection (Room 4, Panel 6) – Roof to Floor

Table 5-7
Panel 7 Data Analysis

Extensometers								
Field Tag	Location	Figure Number	Date of Last Reading	Collar Displacement Relative to Deepest Anchor (inches)	Displacement Rate 2012 to 2013 (in/year)	Displacement Rate ¹ 2011 to 2012 (in/year)	Rate Change Percent ¹	Comments
51X-GE-00416	S2180-W585	5-63	06/28/13	2.278	1.1	1.4	-21%	
51X-GE-00417	S2180-W985	5-64	06/28/13	2.638	1.3	1.6	-19%	
51X-GE-00425	W390-S2350	5-65	06/28/13	1.771	0.9	1.2	-25%	
51X-GE-00426	W520-S2350	5-66	06/28/13	2.125	1.1	1.4	-21%	
51X-GE-00418	W660-S2350	5-67	06/28/13	2.512	1.3	1.6	-19%	
51X-GE-00419	W790-S2350	5-68	06/28/13	1.952	1.2	1.4	-14%	
51X-GE-00420	W920-S2350	5-69	06/28/13	0.426	1.2	N/A	N/A	The instrumenting of Room 5 was delayed due to muck piles in Room.
51X-GE-00421	W1050-S2350	5-70	06/28/13	2.259	1.1	1.4	-21%	
51X-GE-00422	W1190-S2350	5-71	06/28/13	2.527	1.2	1.6	-25%	
51X-GE-00423	S2520-W585	5-72	06/28/13	2.396	1.3	1.5	-13%	
51X-GE-00424	S2520-W985	5-73	06/28/13	2.397	1.3	1.5	-13%	

Table 5-7
Panel 7 Data Analysis (Continued)

Convergence Points									
Field Tag	Location	Figure Number	Last Reading 2012 to 2013		Cumulative Displacement (inches)	Closure Rate 2012 to 2013 (in/year)	Closure Rate ¹ 2011 to 2012 (in/year) ¹	Rate Change Percent ¹	Comments
			Date	Inches					
S2180-W285-2 A-C	S2180-W285	5-74	06/05/13	3.598	4.044	1.5	2.1	-29%	
S2180-W390-3 A-C	S2180-W390	5-75	06/05/13	1.606	7.306	4.0	5.4	-26%	
S2180-W460-3 A-C	S2180-W460	5-76	06/05/13	1.702	9.926	4.2	8.1	-48%	
S2180-W520-3 A-C	S2180-W520	5-77	06/05/13	1.924	12.834	4.8	10.6	-55%	
S2180-W585-4 A-C	S2180-W585	5-78	06/05/13	1.861	11.838	4.6	7.1	-35%	
S2180-W660-4 A-C	S2180-W660	5-79	06/05/13	1.588	10.997	3.9	8.2	-52%	
S2180-W725-4 A-C	S2180-W725	5-80	06/05/13	2.042	9.461	5.1	7.7	-34%	
S2180-W790-3 A-C	S2180-W790	5-81	06/05/13	1.383	11.955	3.5	10.4	-67%	
S2180-W855-3 A-C	S2180-W855	5-82	06/05/13	1.34	11.714	3.4	9.8	-66%	
S2180-W920-3 A-C	S2180-W920	5-83	06/05/13	1.161	11.042	2.9	9.2	-68%	
S2180-W985-4 A-C	S2180-W985	5-84	06/05/13	1.031	17.077	2.6	14.0	-82%	
S2180-W1050-2 A-C	S2180-W1050	5-85	06/05/13	1.089	9.662	2.7	9.1	-70%	
S2180-W1120-3 A-C	S2180-W1120	5-86	06/04/13	1.25	10.499	3.1	8.1	-61%	
S2180-W1190-3 A-C	S2180-W1190	5-87	06/04/13	0.948	7.166	2.4	5.9	-60%	
W390-S2275-3 A-C	W390-S2275	5-88	06/04/13	4.371	12.305	5.6	9.1	-38%	
W390-S2350-3 A-C	W390-S2350	5-89	06/04/13	4.197	10.761	5.4	5.9	-9%	
W390-S2350 B-D	W390-S2350	5-89	06/04/13	0.213	0.213	2.9	N/A	N/A	B-D chords not installed '11-'12.
W390-S2425-3 A-C	W390-S2425	5-90	06/04/13	2.856	12.923	3.7	10.8	-66%	
W520-S2275-3 A-C	W520-S2275	5-91	06/04/13	4.727	13.179	5.9	7.3	-19%	
W520-S2350-3 A-C	W520-S2350	5-92	06/04/13	3.615	16.484	4.5	15.2	-70%	
W520-S2350 B-D	W520-S2350	5-92	06/04/13	0.24	0.24	3.2	N/A	N/A	
W520-S2425-3 A-C	W520-S2425	5-93	06/04/13	3.652	12.934	4.6	7.8	-41%	
W660-S2275-3 A-C	W660-S2275	5-94	06/04/13	3.416	12.432	4.4	7.8	-44%	
W660-S2350-3 A-C	W660-S2350	5-95	06/04/13	1.654	18.383	4.3	22.8	-81%	
W660-S2350 B-D	W660-S2350	5-95	06/04/13	0.289	0.289	2.6	N/A	N/A	
W660-S2425-3 A-C	W660-S2425	5-96	06/04/13	2.978	15.532	3.8	14.0	-73%	
W790-S2275-3 A-C	W790-S2275	5-97	06/04/13	1.327	5.931	3.5	7.6	-54%	
W790-S2350-3 A-C	W790-S2350	5-98	06/04/13	1.653	5.944	4.3	7.3	-40%	
W790-S2350 B-D	W790-S2350	5-98	06/04/13	0.328	0.328	3.0	N/A	N/A	

Table 5-7
Panel 7 Data Analysis (Continued)

Convergence Points (Continued)									
Field Tag	Location	Figure Number	Last Reading 2012 to 2013		Cumulative Displacement (inches)	Closure Rate 2012 to 2013 (in/year)	Closure Rate ¹ 2011 to 2012 (in/year)	Rate Change Percent ¹	Comments
			Date	Inches					
W790-S2425-2 A-C	W790-S2425	5-99	06/04/13	1.379	3.678	3.6	7.8	-54%	
W920-S2275-3 A-C	W920-S2275	5-100	06/04/13	1.123	4.191	3.0	18.1	-84%	
W920-S2350-3 A-C	W920-S2350	5-101	06/04/13	1.261	4.277	3.3	19.2	-83%	
W920-S2350 B-D	W920-S2350	5-101	06/04/13	0.316	0.316	2.8	N/A	N/A	
W920-S2425-3 A-C	W920-S2425	5-102	06/04/13	1.397	4.240	3.7	13.0	-72%	
W1050-S2275-3 A-C	W1050-S2275	5-103	06/04/13	1.006	10.635	2.7	9.7	-73%	
W1050-S2350-3 A-C	W1050-S2350	5-104	06/04/13	1.132	12.423	3.0	7.5	-60%	
W1050-S2350 B-D	W1050-S2350	5-104	06/04/13	0.352	0.352	3.1	N/A	N/A	
W1050-S2425-3 A-C	W1050-S2425	5-105	06/04/13	0.956	10.477	2.5	9.4	-73%	
W1190-S2275-3 A-C	W1190-S2275	5-106	06/04/13	0.905	10.935	2.3	10.1	-77%	
W1190-S2350-4 A-C	W1190-S2350	5-107	06/04/13	0.986	11.902	2.6	7.1	-64%	
W1190-S2350 B-D	W1190-S2350	5-107	06/04/13	0.338	0.338	3.0	N/A	N/A	
W1190-S2425-4 A-C	W1190-S2425	5-108	06/04/13	0.982	9.48	2.6	6.0	-57%	
S2520-W285-4 A-C	S2520-W285	5-109	06/04/13	3.854	8.829	4.8	7.2	-33%	
S2520-W390-3 A-C	S2520-W390	5-110	06/04/13	3.439	10.722	4.3	8.2	-48%	
S2520-W455-3 A-C	S2520-W455	5-111	06/04/13	3.468	11.158	4.3	7.9	-45%	
S2520-W520-3 A-C	S2520-W520	5-112	06/04/13	3.008	15.786	3.8	8.9	-58%	
S2520-W585-4 A-C	S2520-W585	5-113	06/04/13	1.237	8.903	3.3	7.4	-55%	'11-'12 rate from initial install.
S2520-W660-3 A-C	S2520-W660	5-114	06/04/13	1.575	15.009	4.1	14.3	-71%	
S2520-W725-5 A-C	S2520-W725	5-115	06/04/13	1.73	10.681	4.5	8.0	-44%	
S2520-W790-3 A-C	S2520-W790	5-116	06/04/13	1.428	9.529	3.7	9.0	-59%	
S2520-W855-3 A-C	S2520-W855	5-117	06/04/13	1.880	15.813	4.9	18.7	-74%	
S2520-W920-4 A-C	S2520-W920	5-118	06/04/13	1.305	10.674	3.4	7.7	-56%	
S2520-W985-3 A-C	S2520-W985	5-119	06/04/13	1.313	11.527	3.4	10.1	-66%	
S2520-W1050-4 A-C	S2520-W1050	5-120	06/04/13	1.108	9.621	2.9	7.9	-63%	
S2520-W1120-4 A-C	S2520-W1120	5-121	06/04/13	0.960	16.032	2.5	17.6	-86%	
S2520-W1190-3 A-C	S2520-W1190	5-122	06/04/13	0.800	8.000	2.1	6.7	-69%	

¹N/A – Insufficient data available to perform the calculation. This is usually due to the inability to read the instruments because of activities such as: the temporary removal of an instrument due to floor, rib or back trimming; locations blocked by equipment or waste disposal, installation timing, etc.

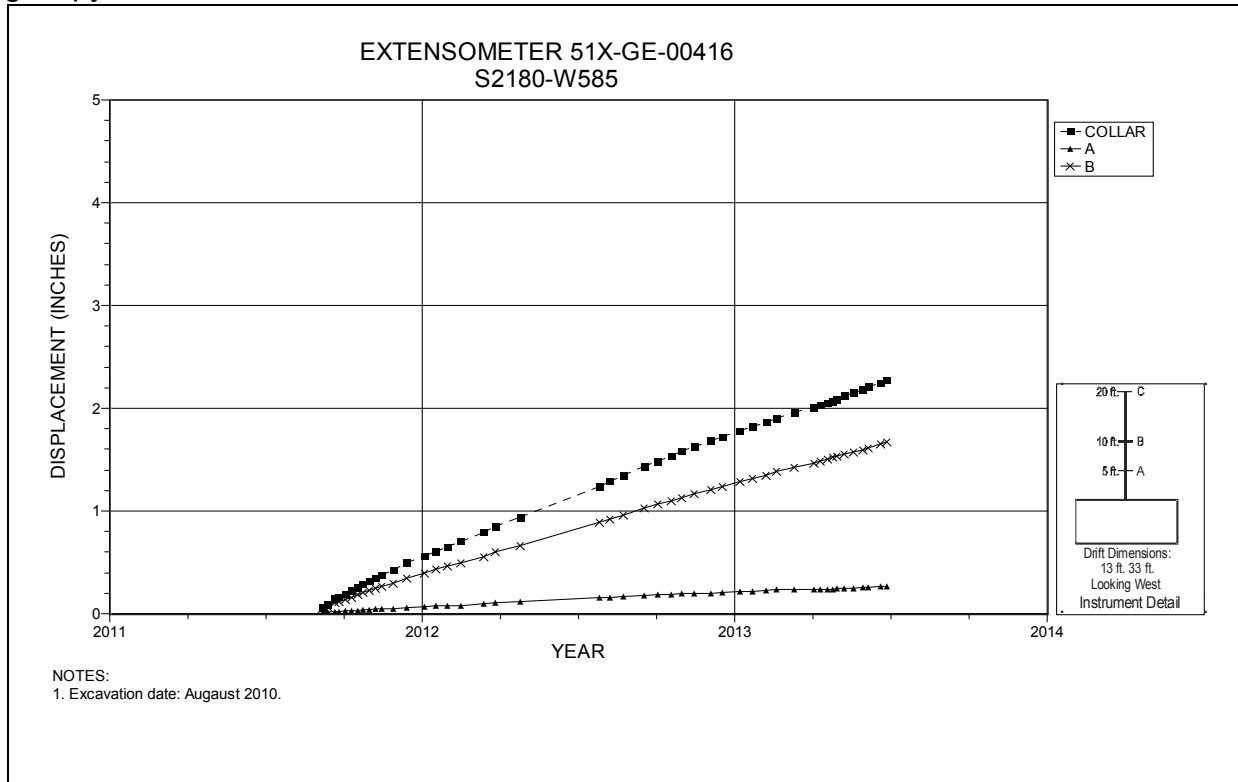

Figure 5-63 Extensometer 51X-GE-00416
S2180 W585 – Roof

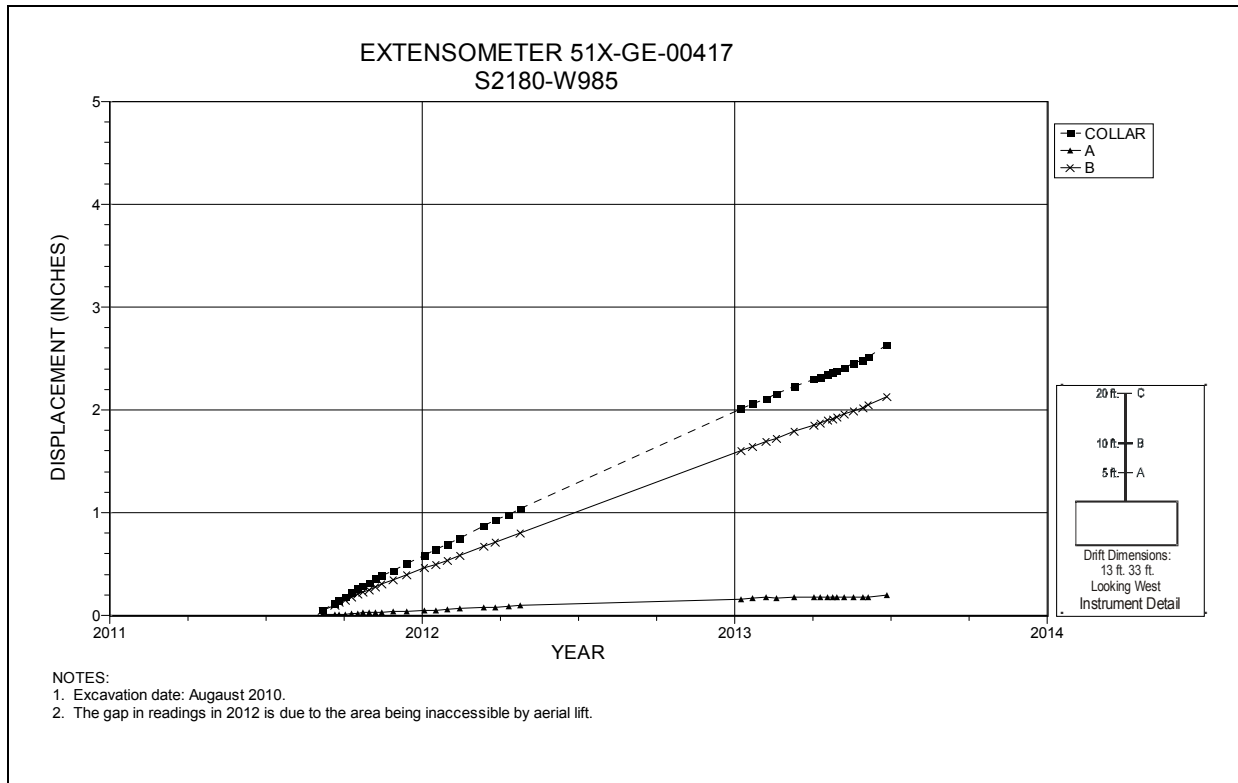

Figure 5-64 Extensometer 51X-GE-00417
S2180 W985 – Roof

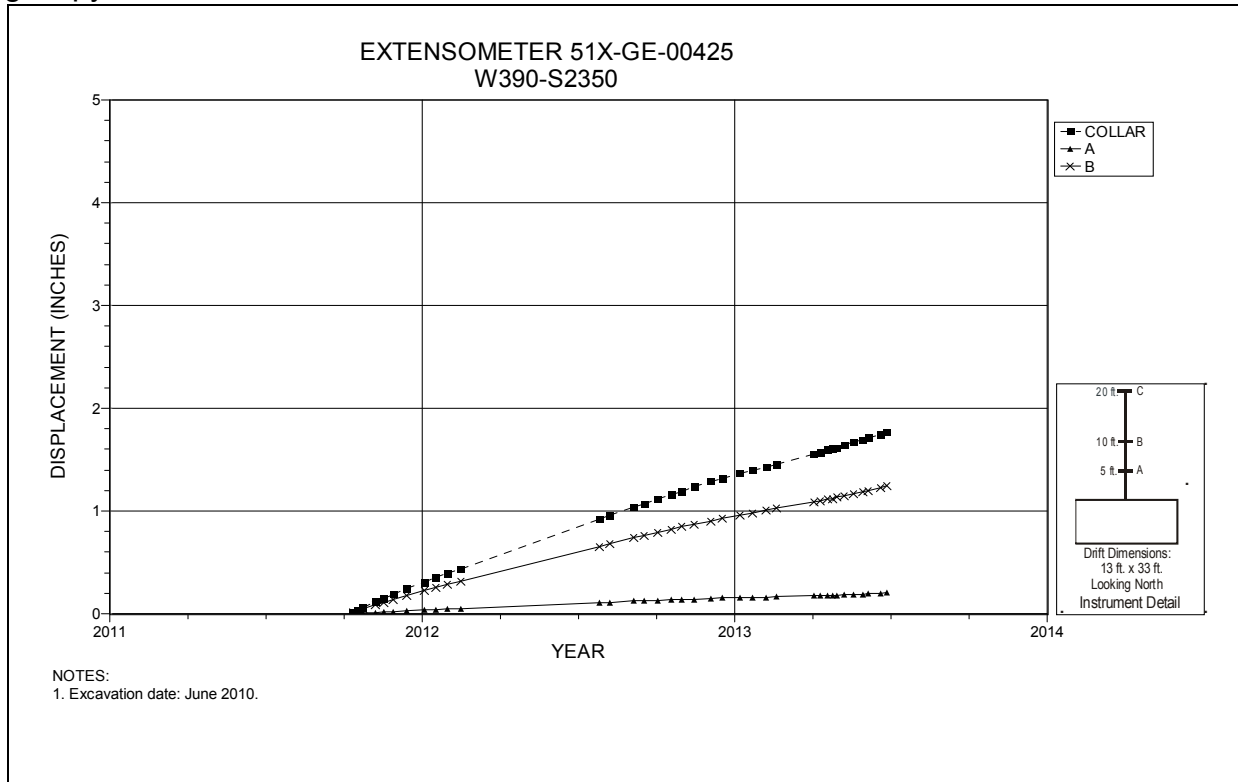

Figure 5-65 Extensometer 51X-GE-00425
Room 1, Panel 7 at W390 S2350 – Room Center – Roof

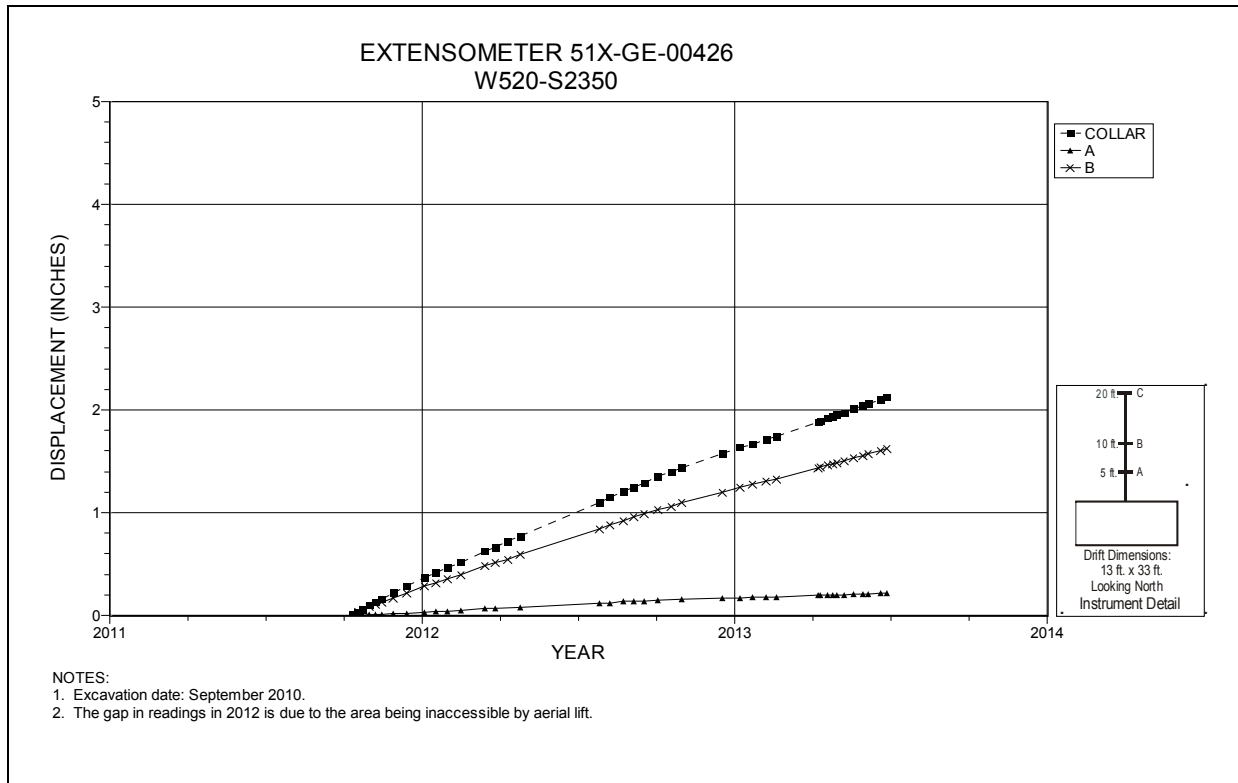

Figure 5-66 Extensometer 51X-GE-00426
Room 2, Panel 7 at W520 S2350 – Room Center – Roof

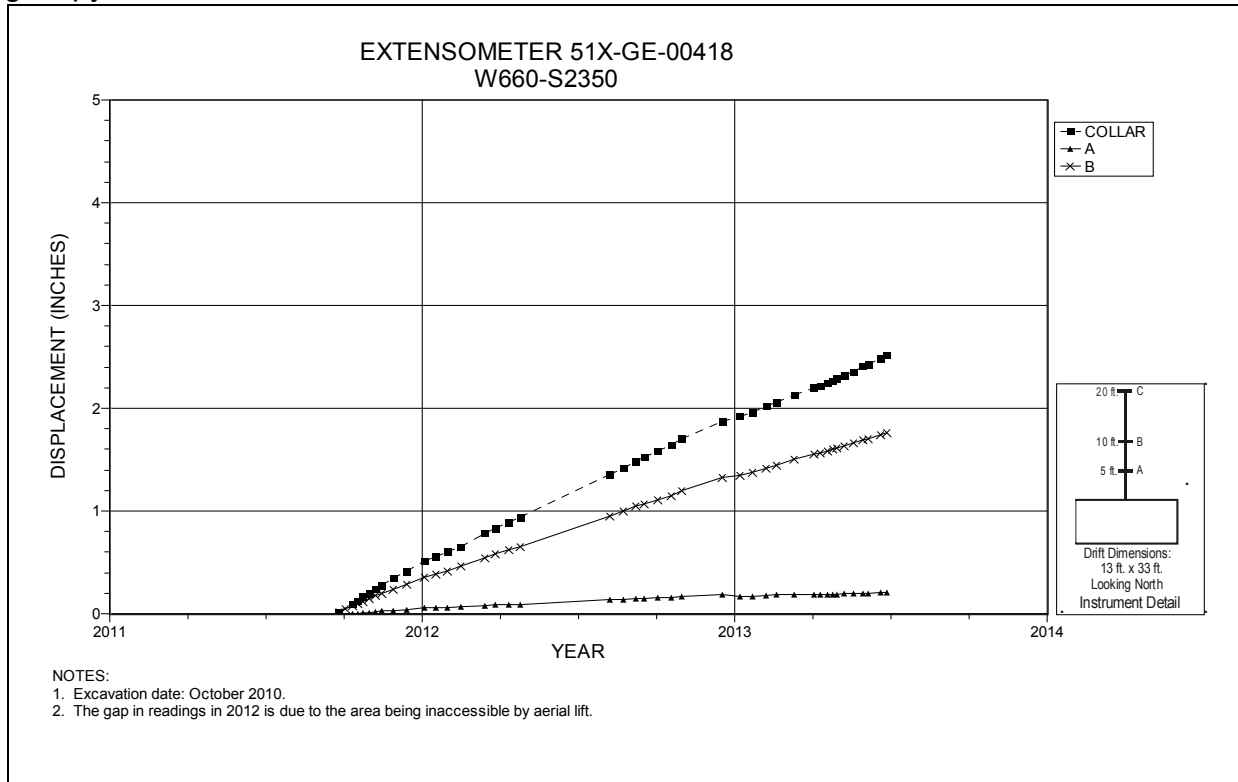

Figure 5-67 Extensometer 51X-GE-00418
Room 3, Panel 7 at W660 S2350 – Room Center – Roof

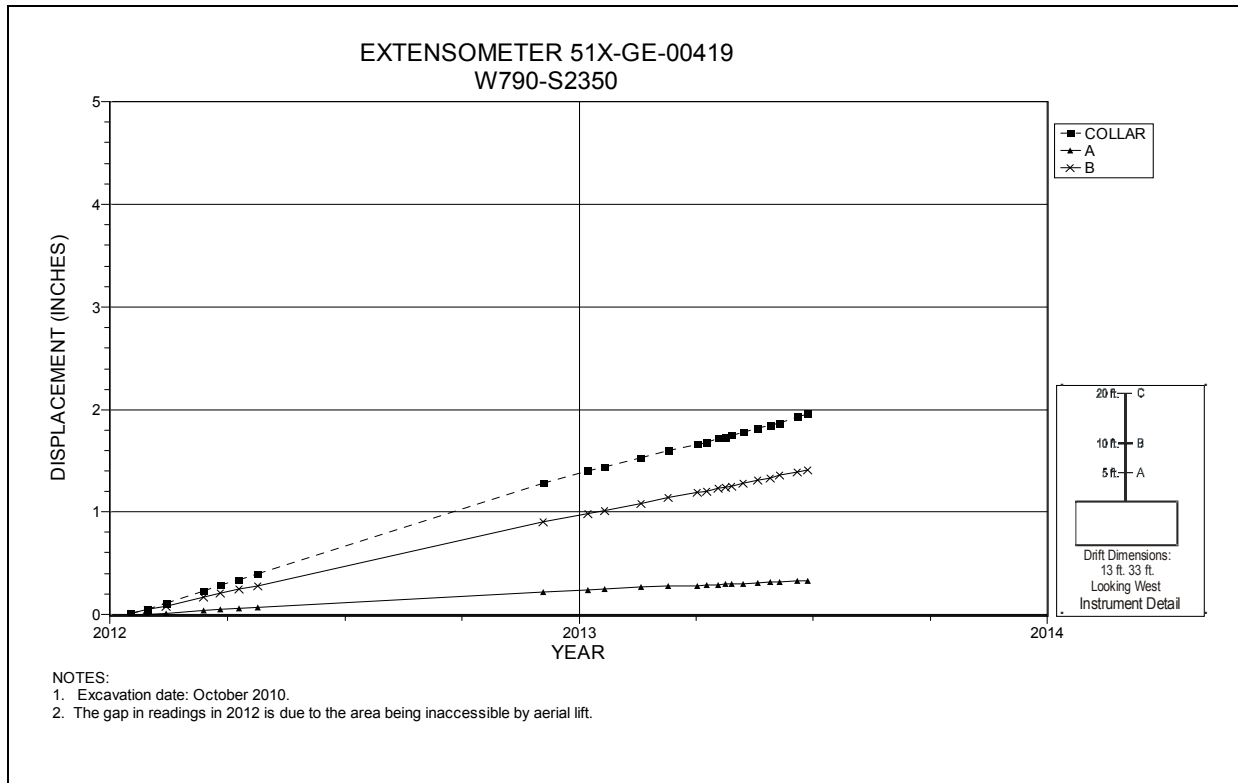

Figure 5-68 Extensometer 51X-GE-00419
Room 4, Panel 7 at W790 S2350 – Room Center – Roof

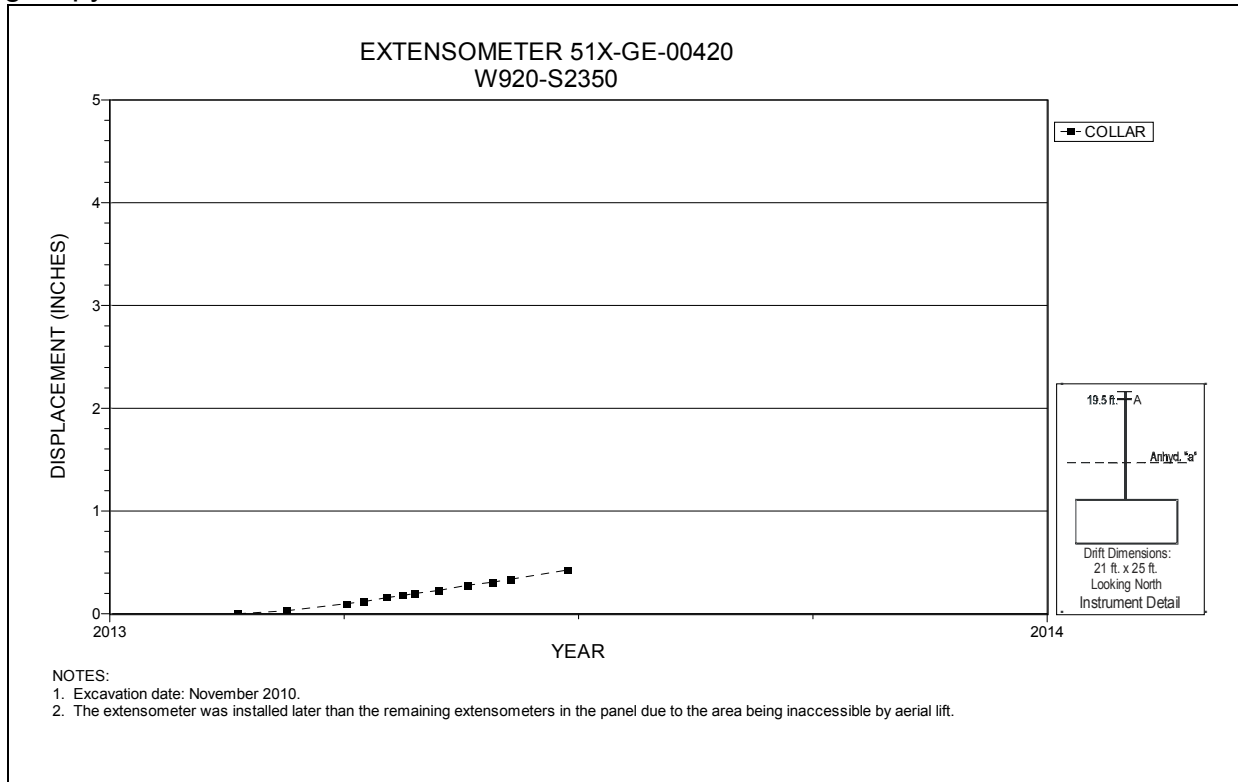

Figure 5-69 Extensometer 51X-GE-00420
Room 5, Panel 7 at W920 S2350 – Room Center – Roof

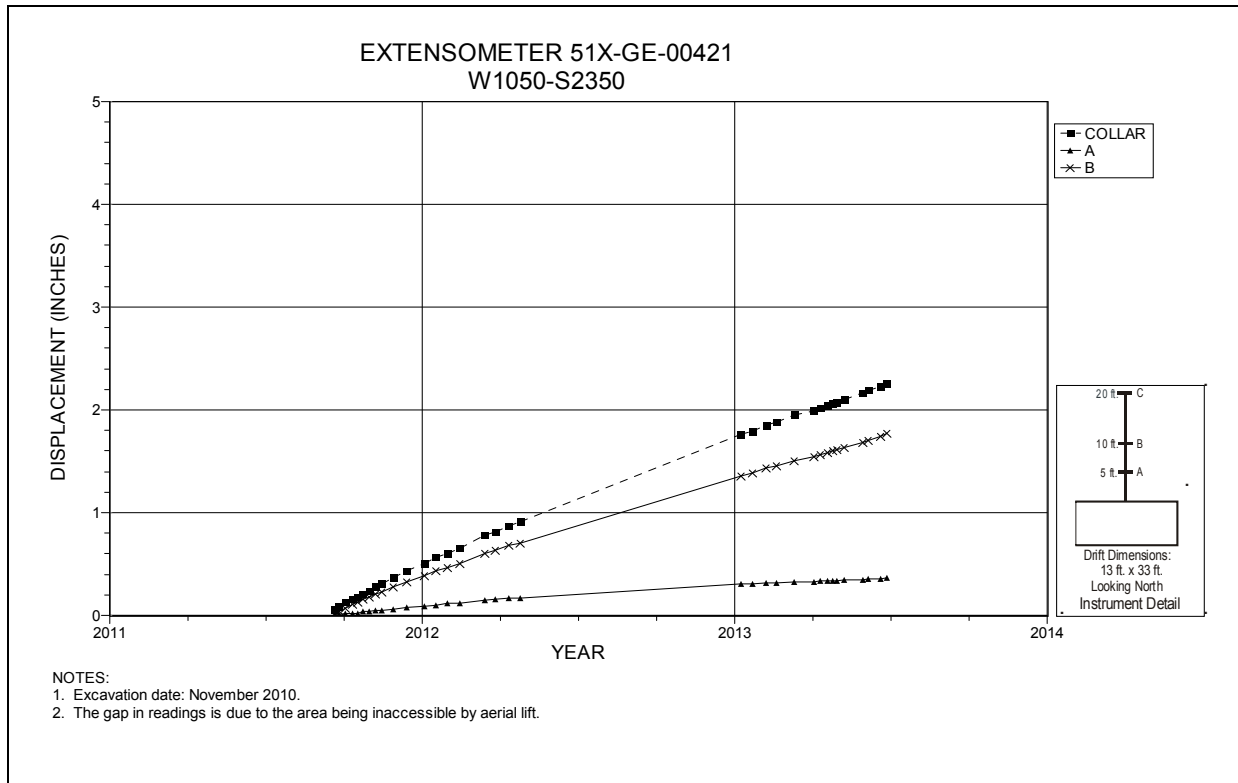

Figure 5-70 Extensometer 51X-GE-00421
Room 6, Panel 7 at W1050 S2350 – Room Center – Roof

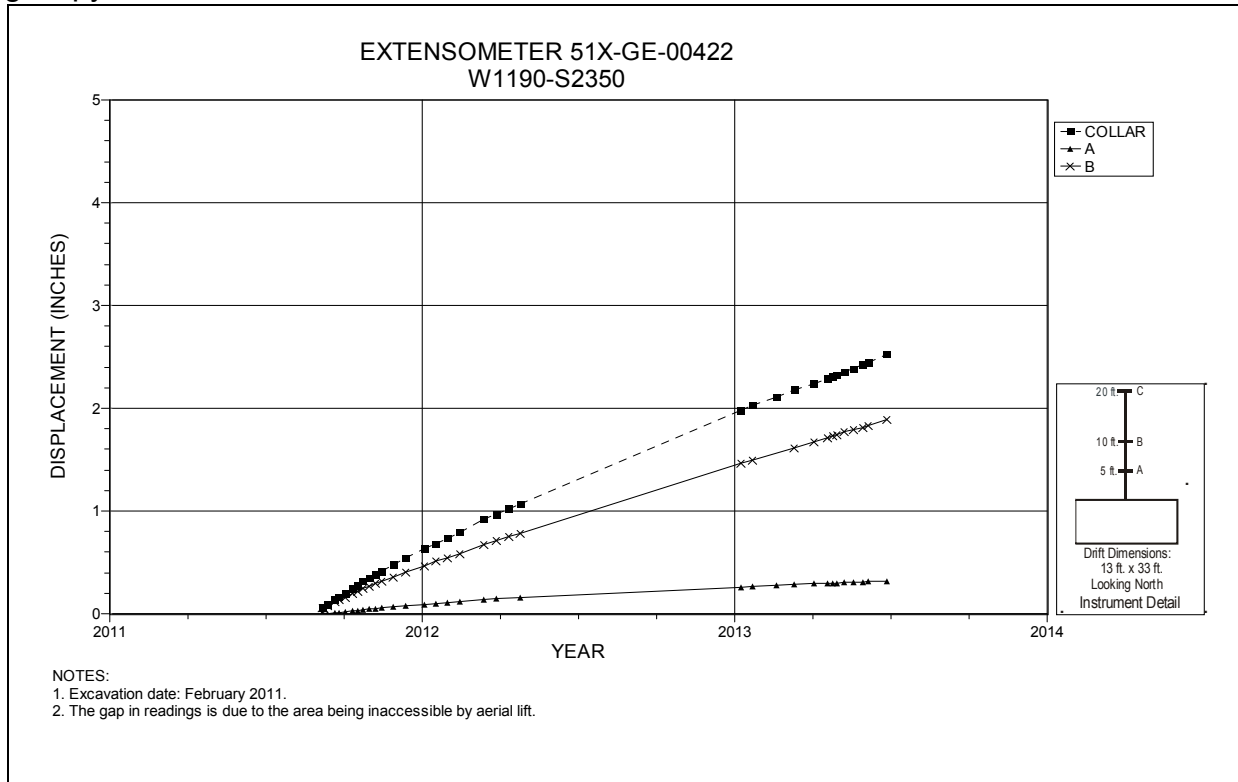

Figure 5-71 Extensometer 51X-GE-00422
Room 7, Panel 7 at W1190 S2350 – Room Center – Roof

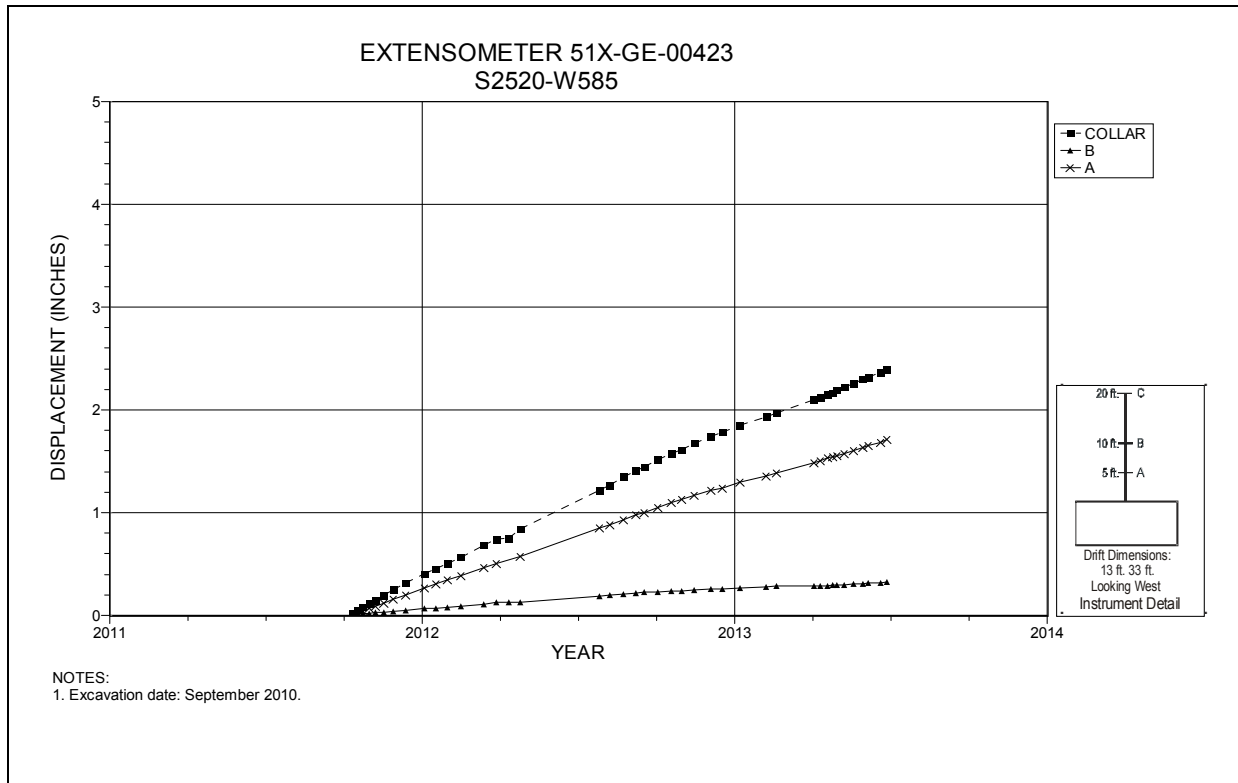

Figure 5-72 Extensometer 51X-GE-00423
S2520 W585 – Roof

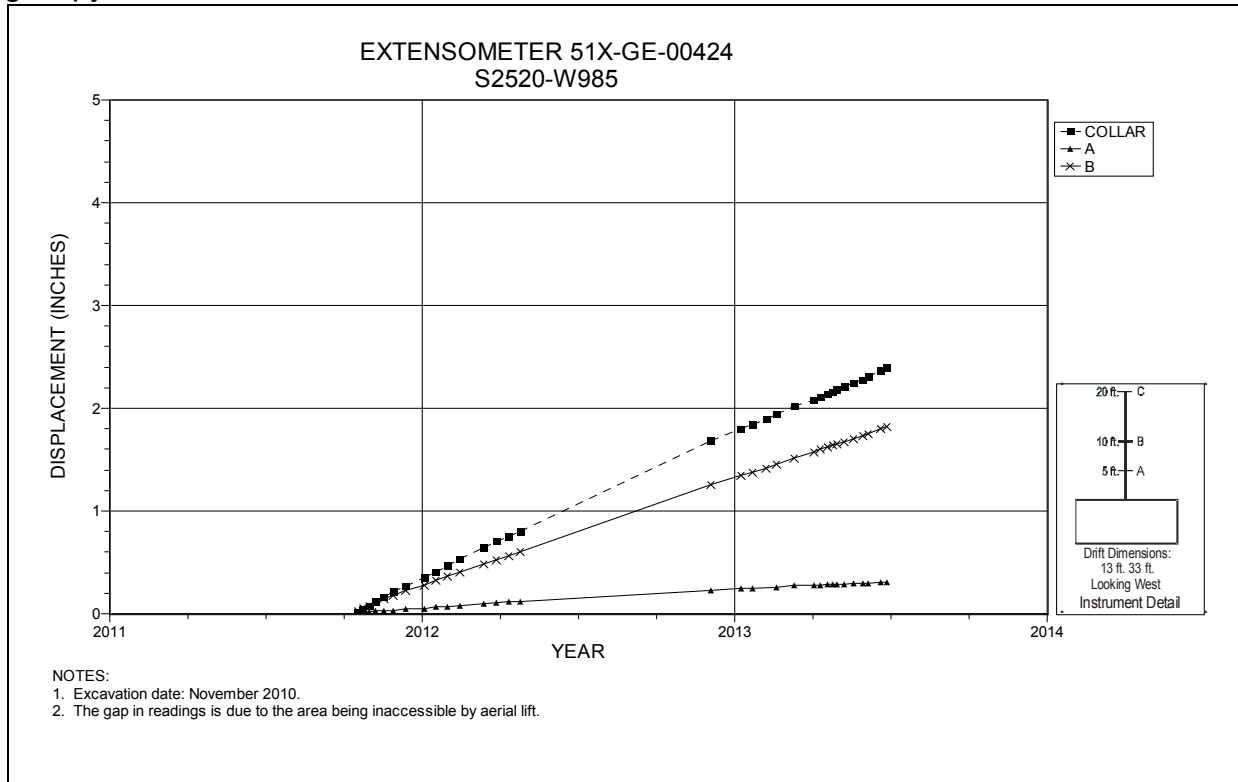

Figure 5-73 Extensometer 51X-GE-00424
S2520 W985 – Roof

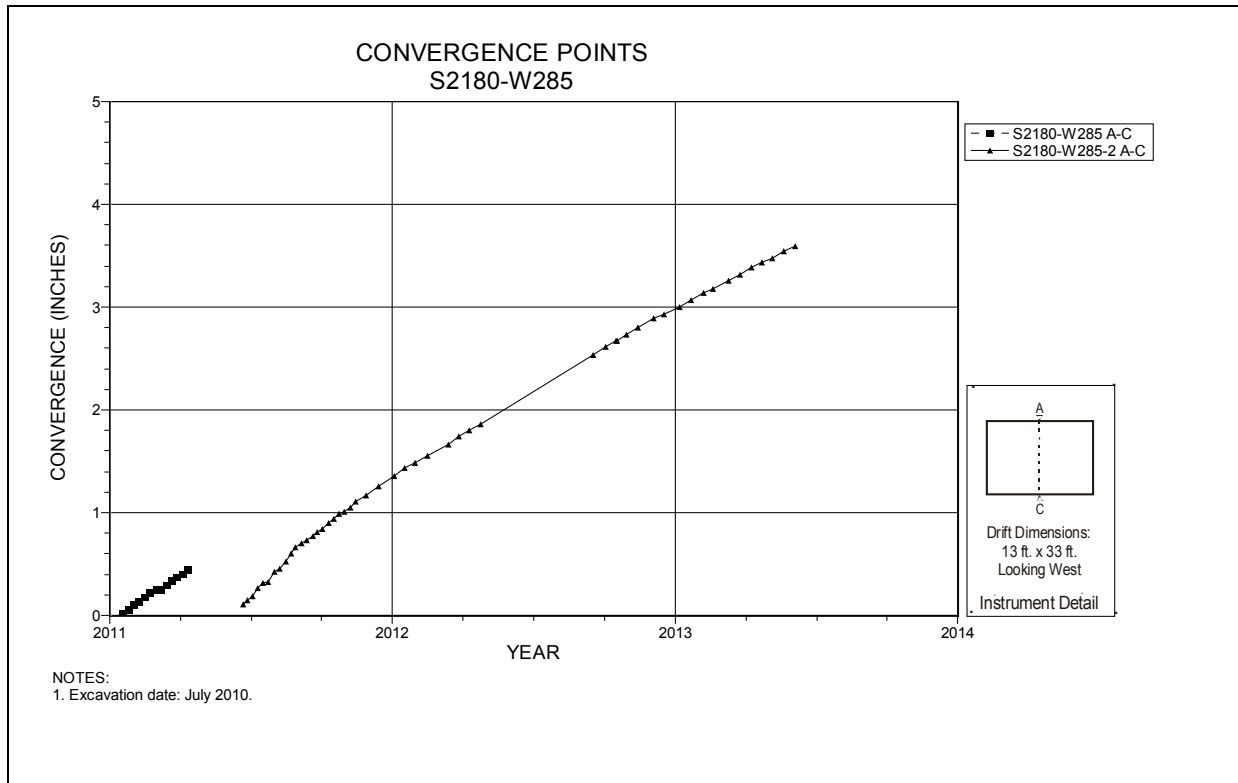
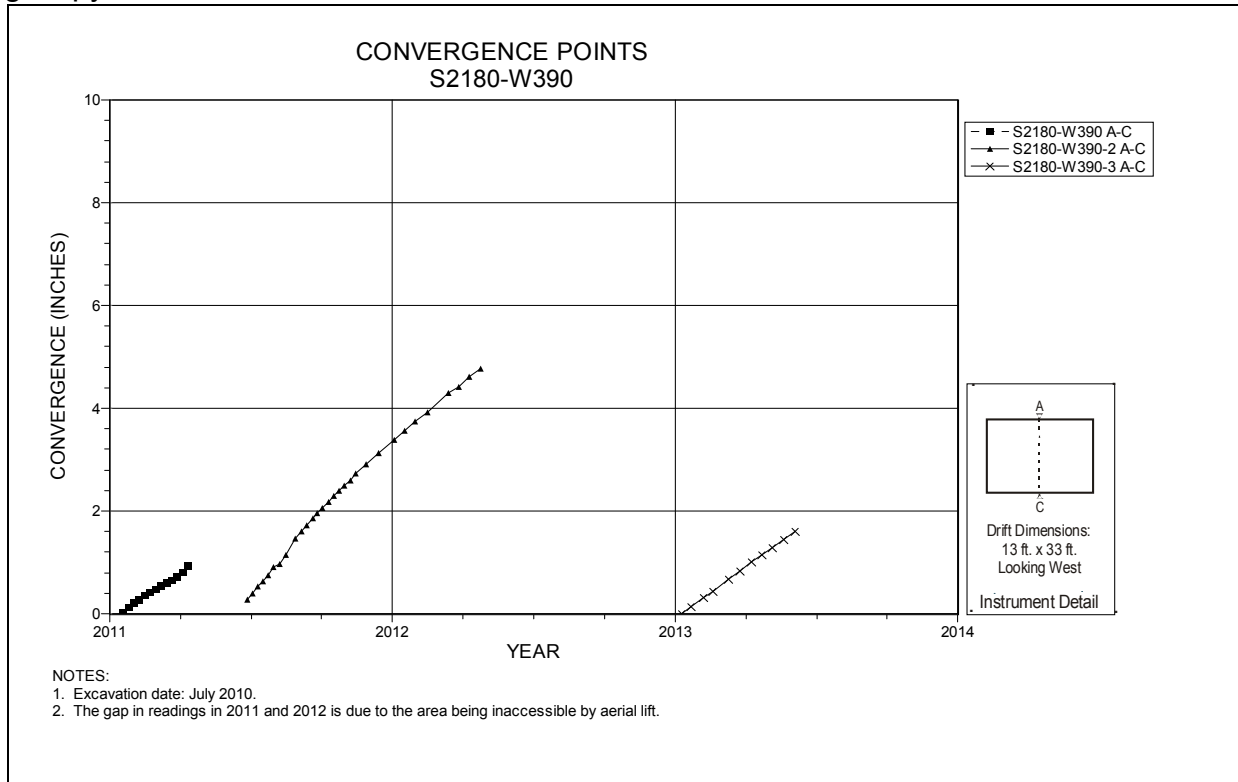
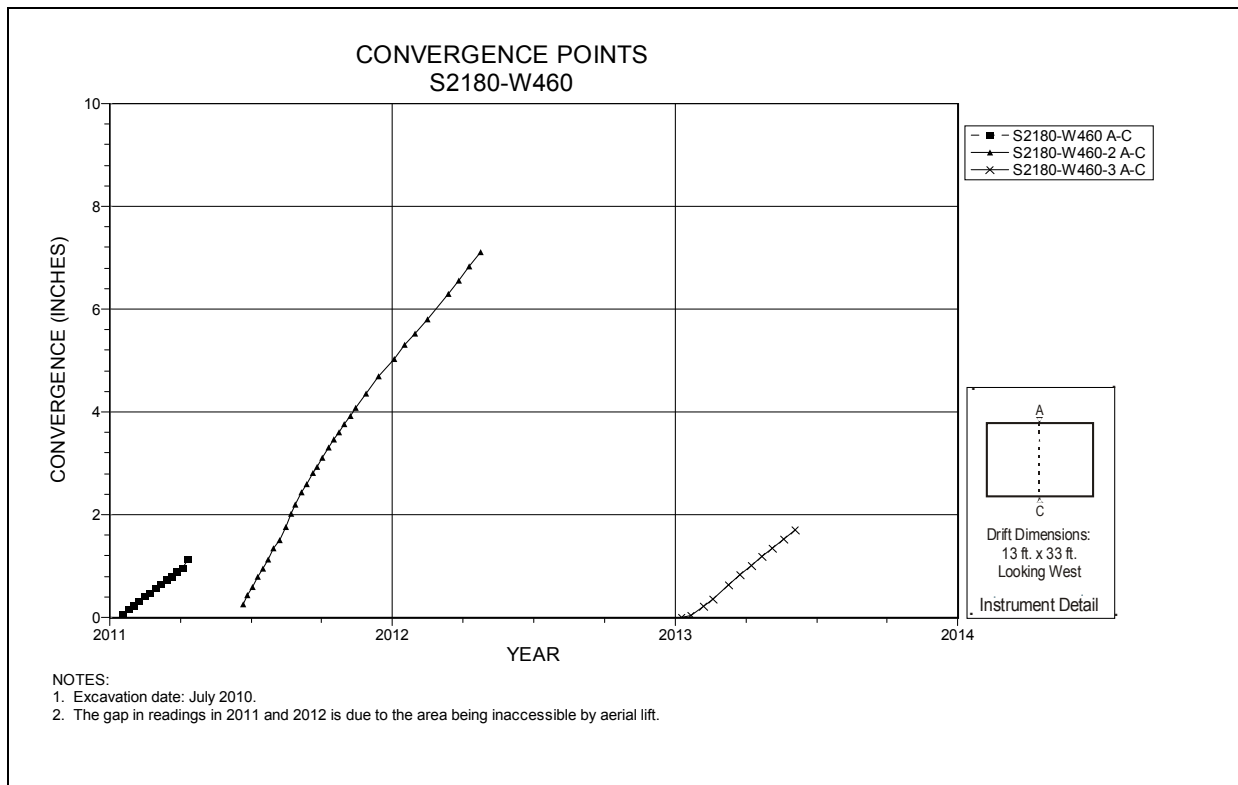

Figure 5-74 Convergence Point Array
S2180 W285 – Roof to Floor



**Figure 5-75 Convergence Point Array
S2180 W390 Intersection (Room 1, Panel 7) – Roof to Floor**



**Figure 5-76 Convergence Point Array
S2180 W460 – Roof to Floor**

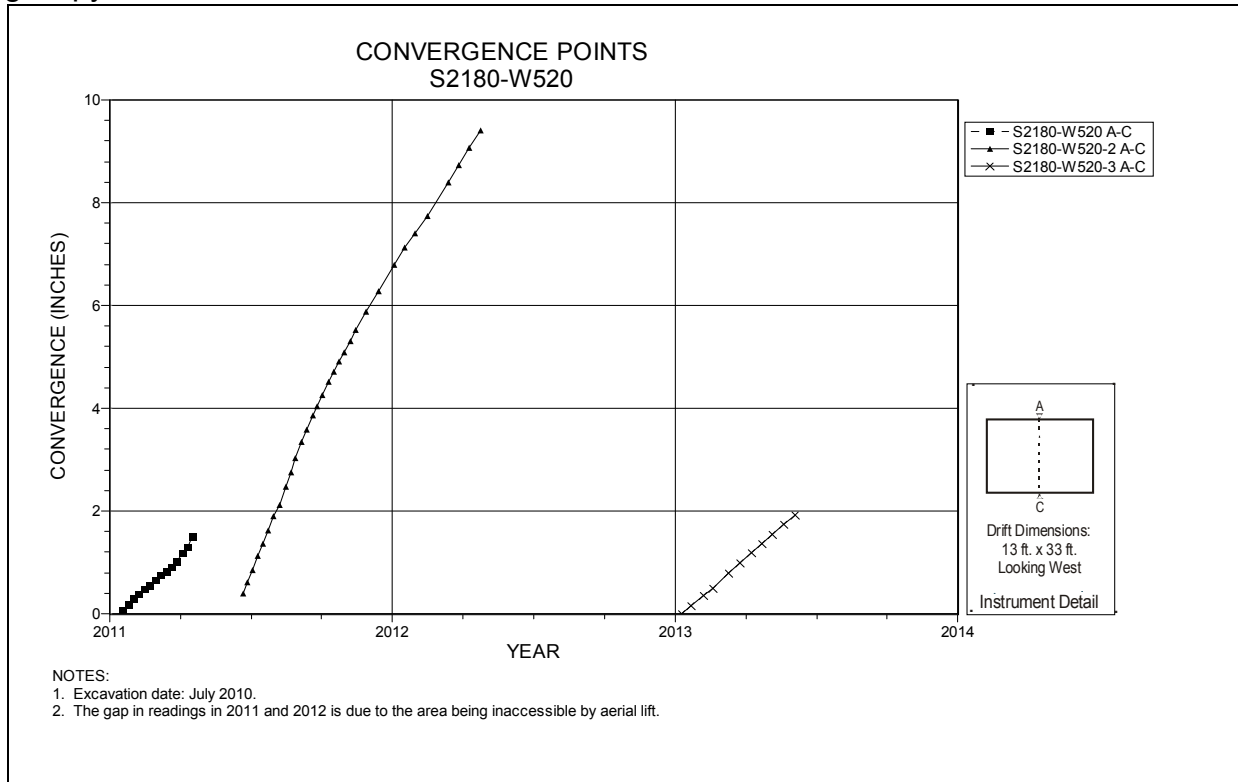

**Figure 5-77 Convergence Point Array
S2180 W520 Intersection (Room 2, Panel 7) – Roof to Floor**

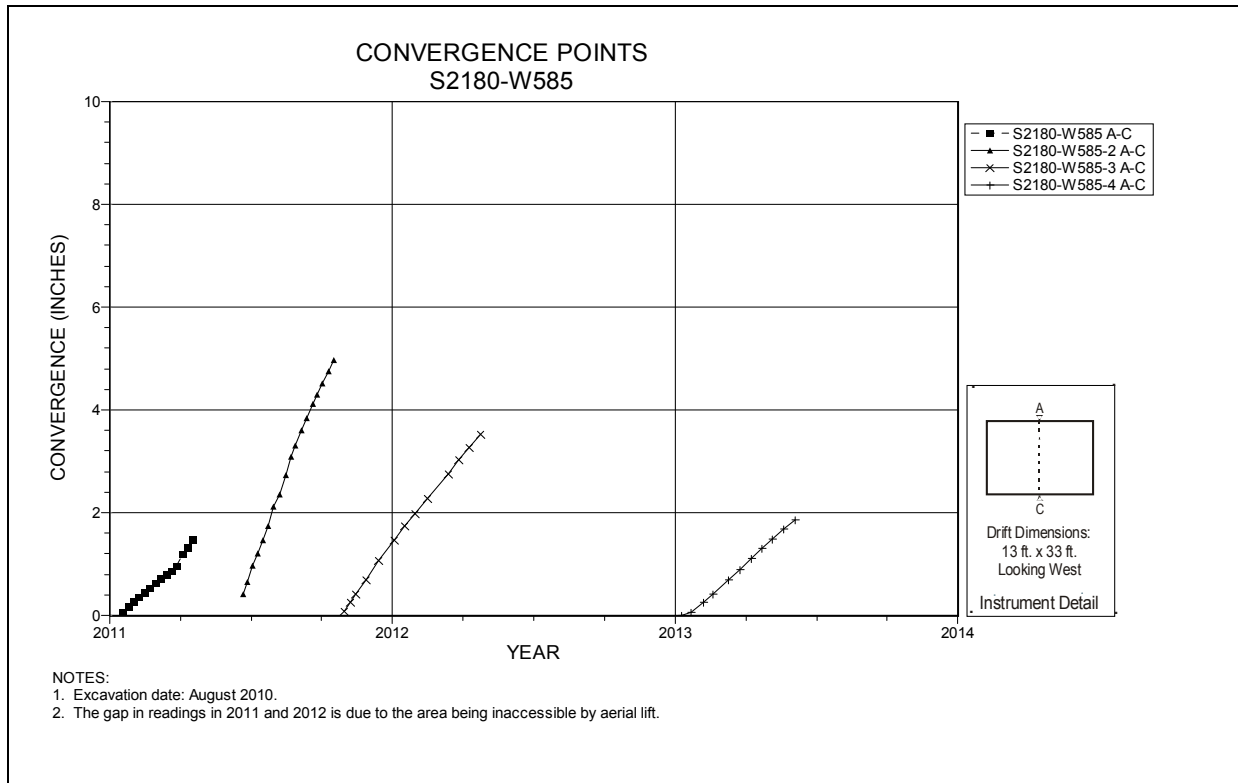

**Figure 5-78 Convergence Point Array
S2180 W585 – Roof to Floor**

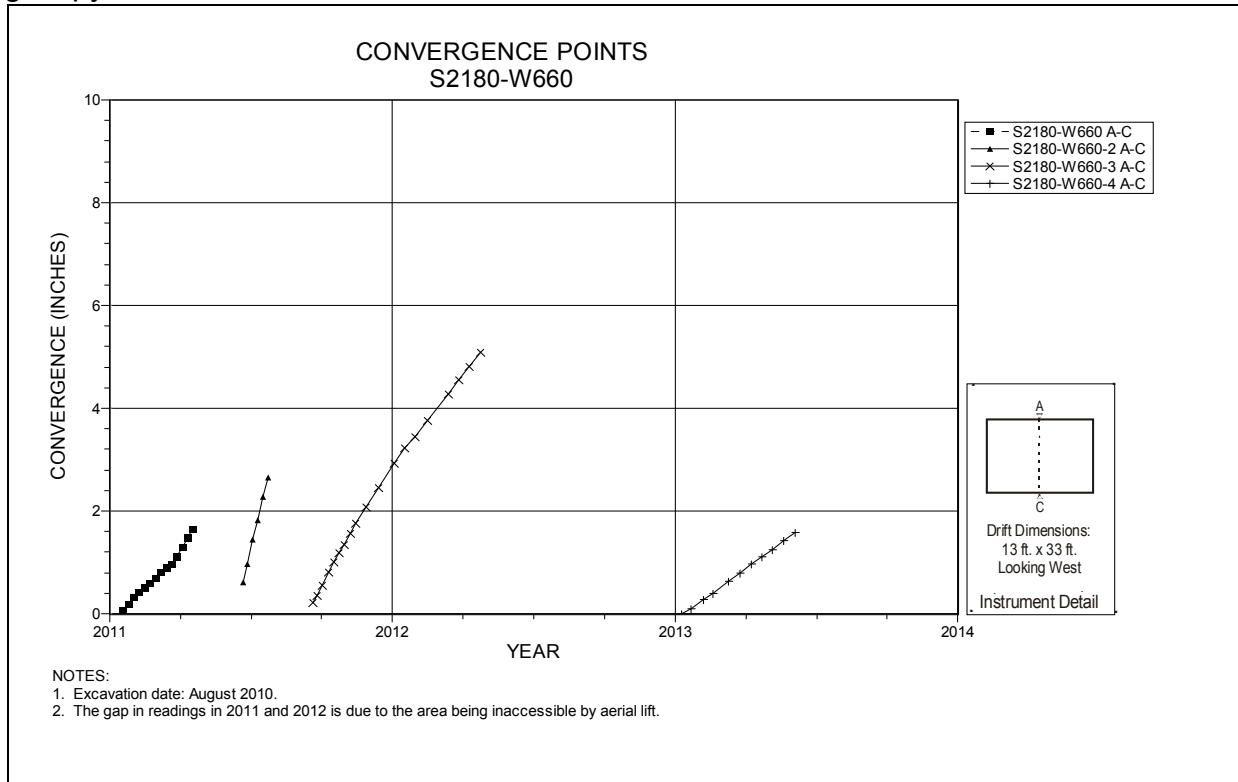

**Figure 5-79 Convergence Point Array
S2180 W660 Intersection (Room 3 Panel 7) – Roof to Floor**

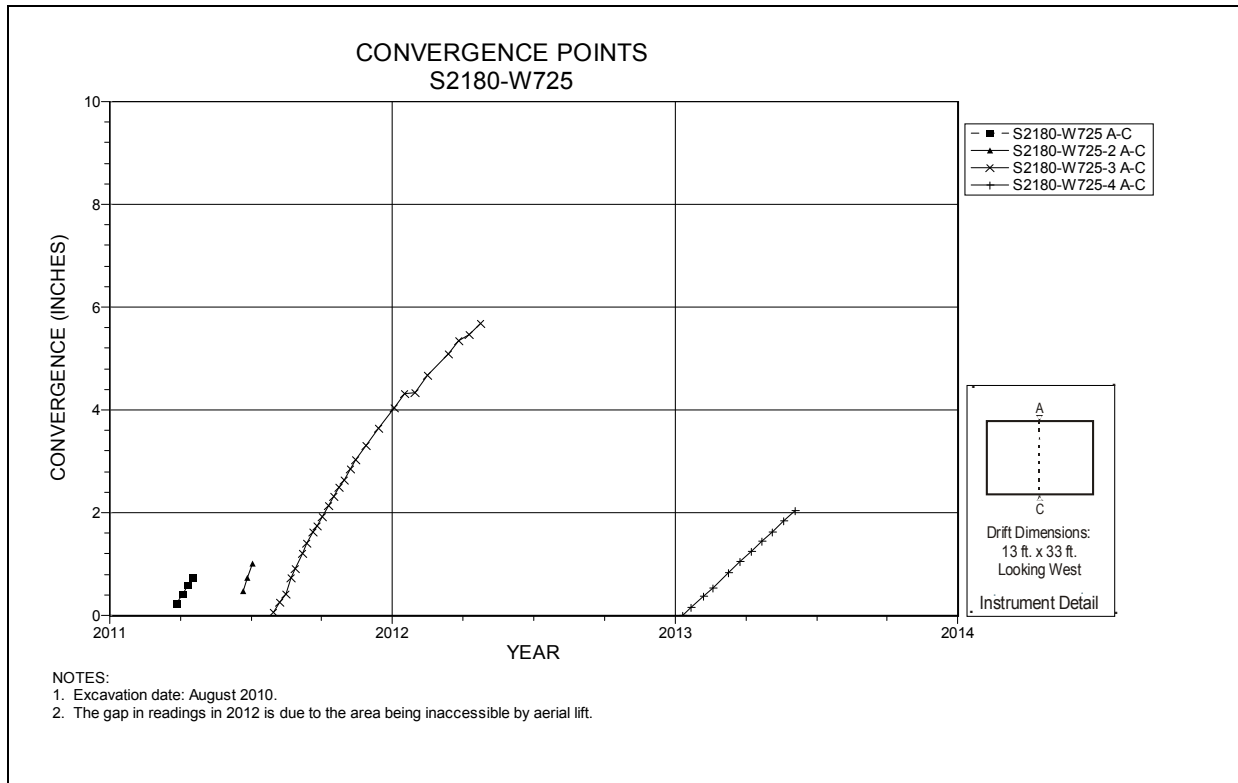

**Figure 5-80 Convergence Point Array
S2180 W725 – Roof to Floor**

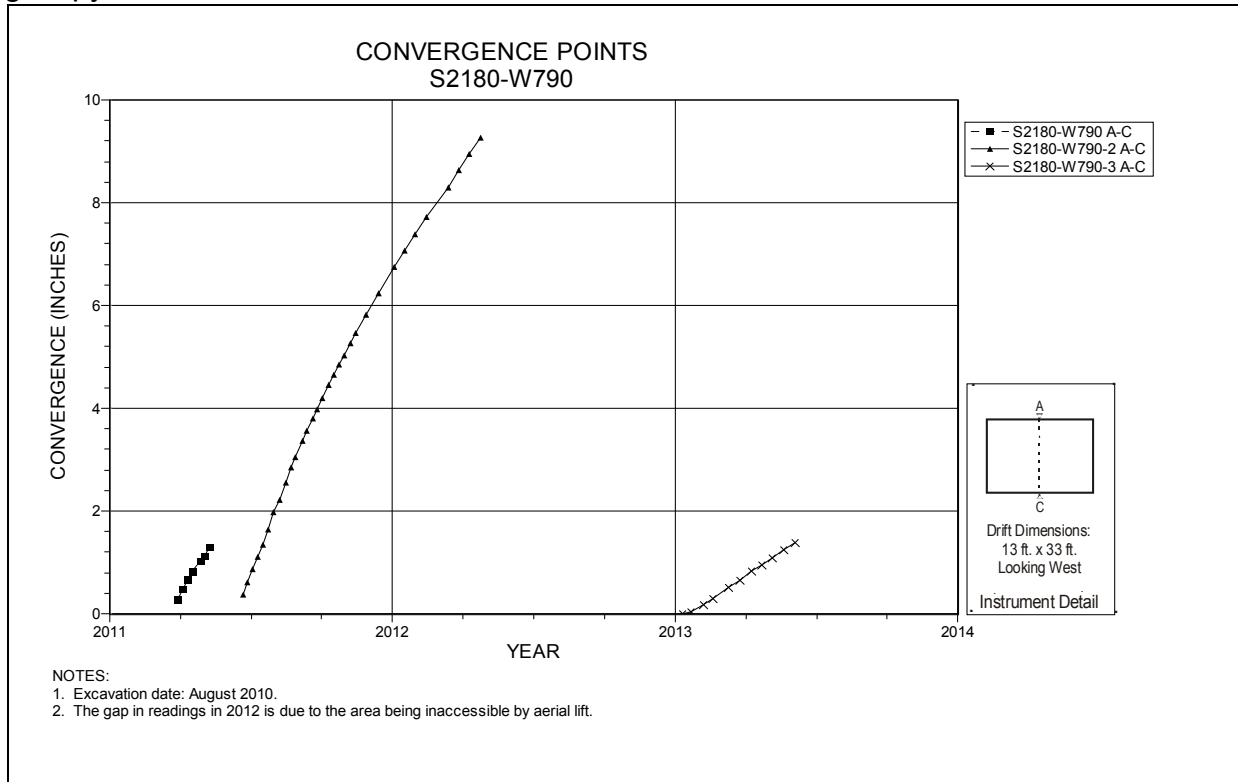

**Figure 5-81 Convergence Point Array
S2180 W790 Intersection (Room 4, Panel 7) – Roof to Floor**

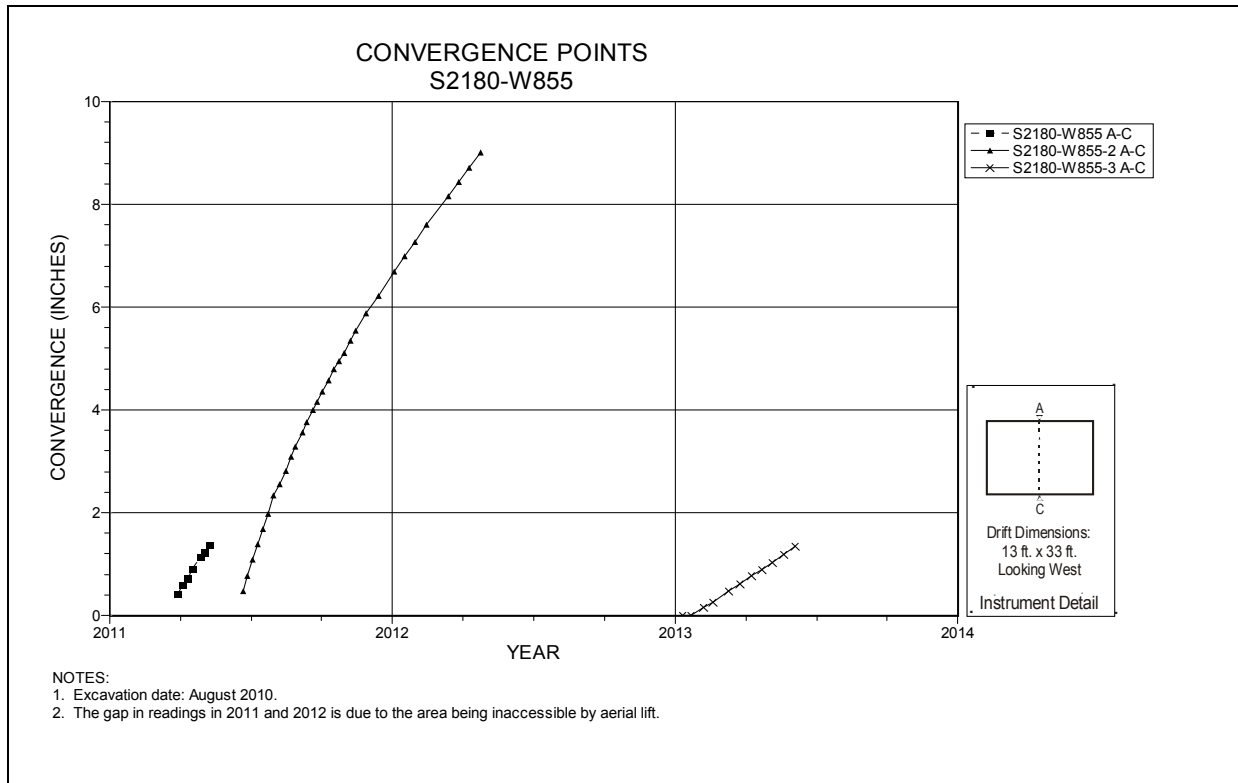

**Figure 5-82 Convergence Point Array
S2180 W855 – Roof to Floor**

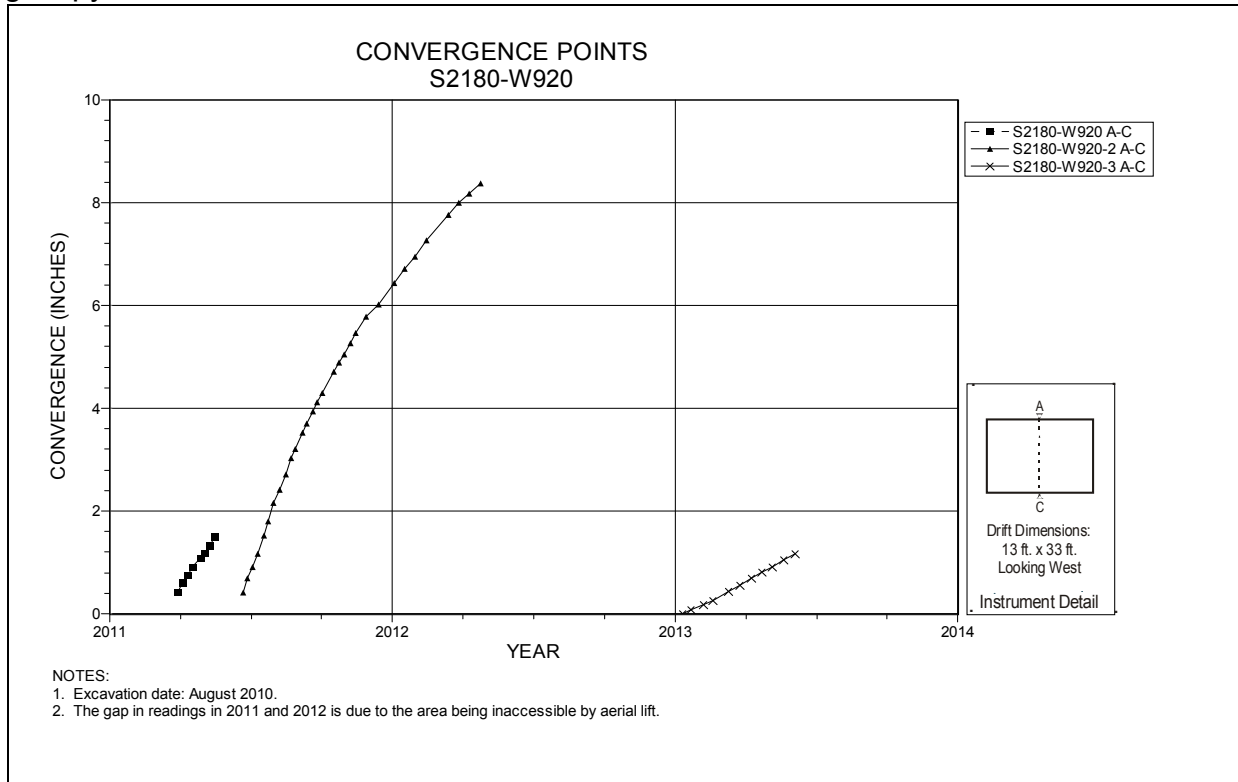

**Figure 5-83 Convergence Point Array
S2180 W920 Intersection (Room 5, Panel 7) – Roof to Floor**

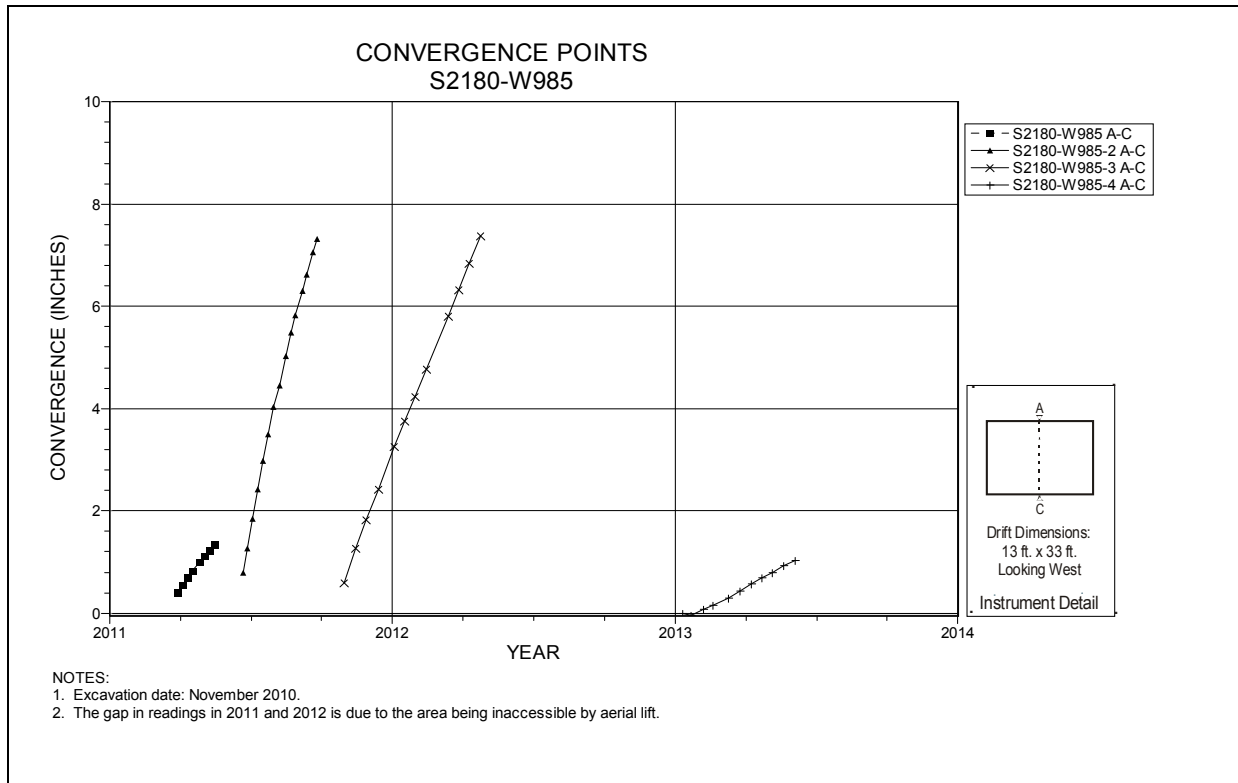

**Figure 5-84 Convergence Point Array
S2180 W985 – Roof to Floor**

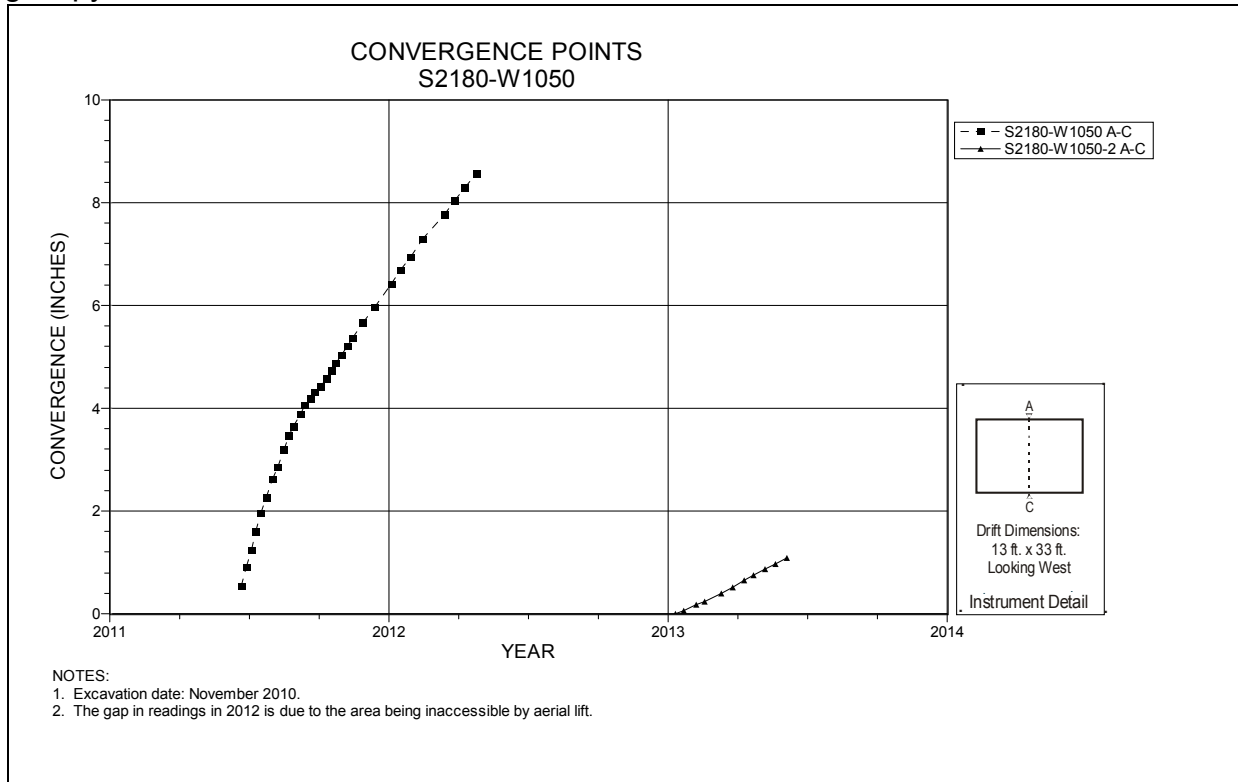

Figure 5-85 Convergence Point Array
S2180 W1050 Intersection (Room 6, Panel 7) – Roof to Floor

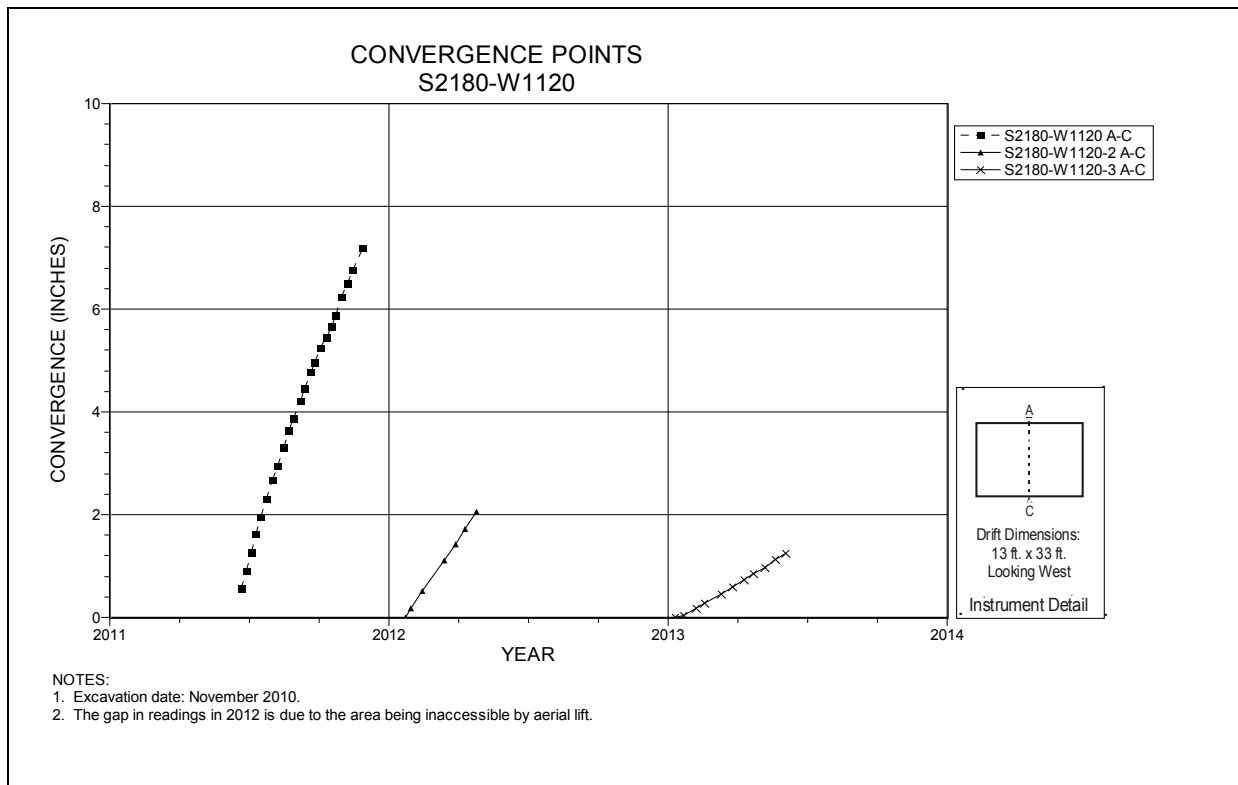
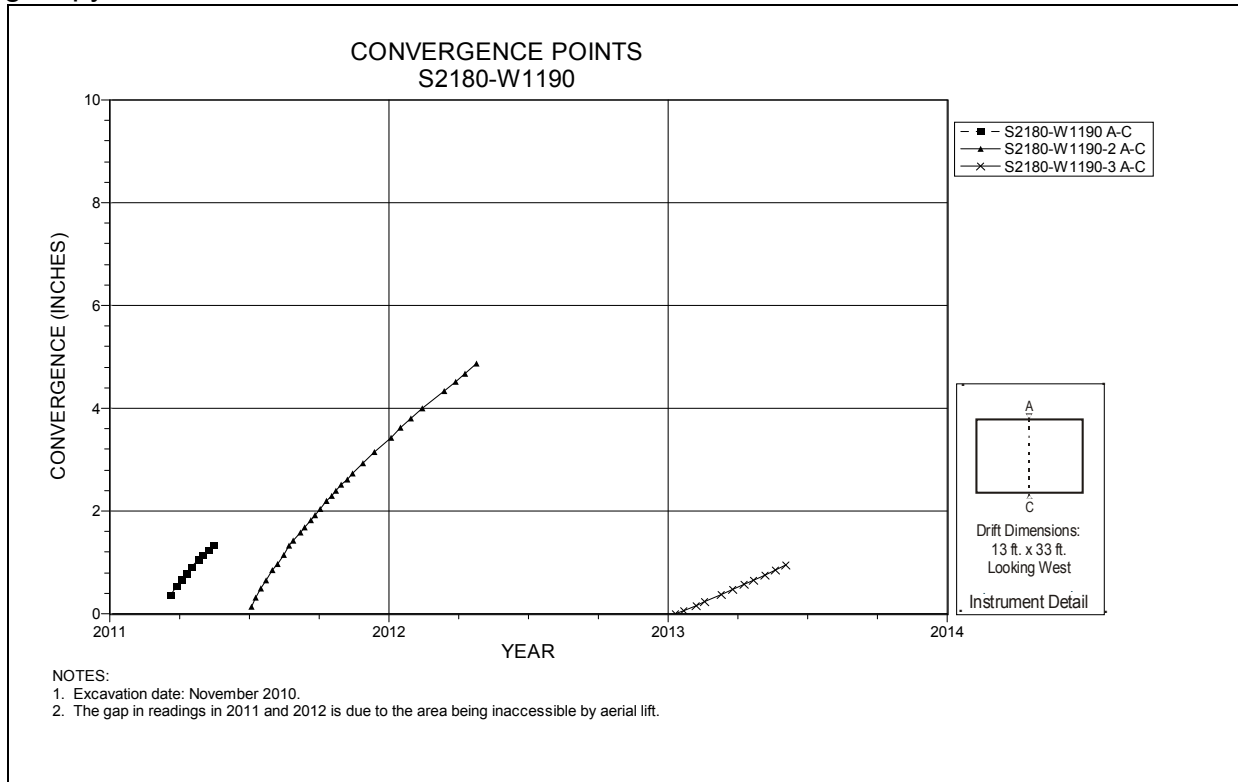
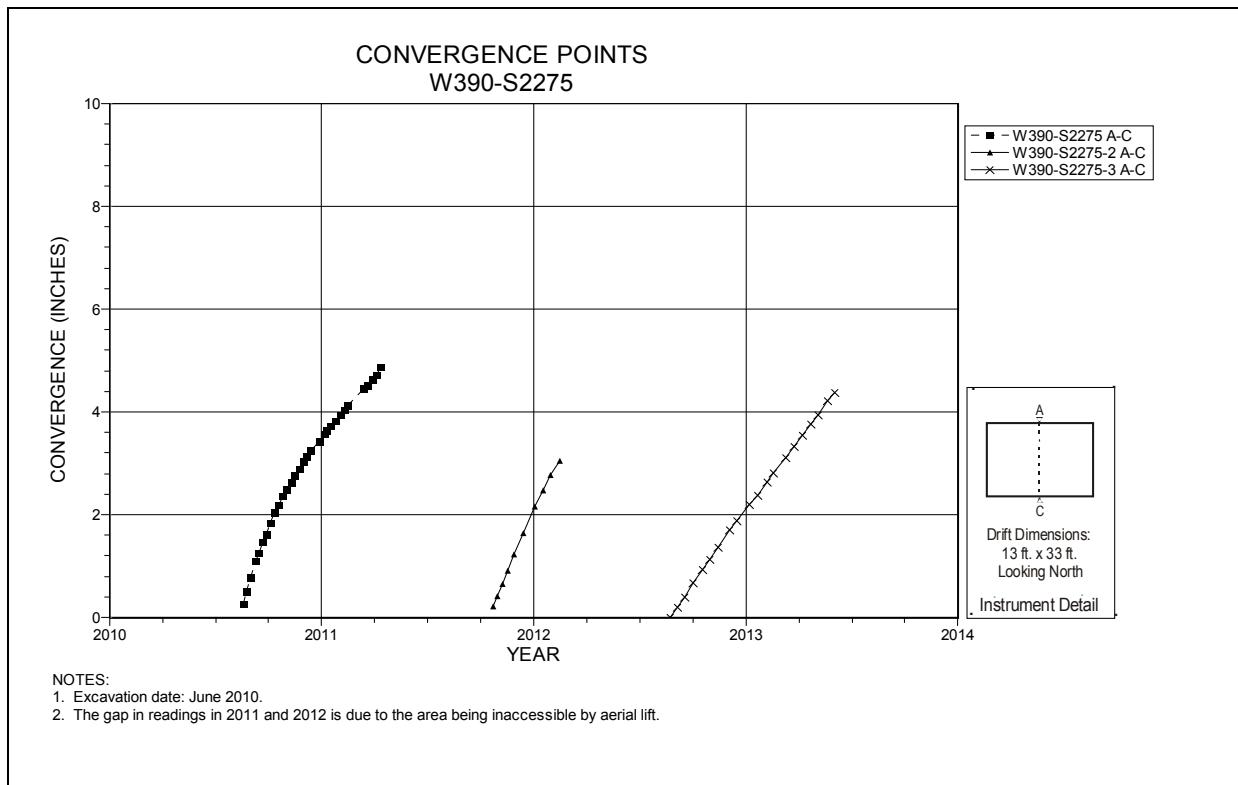

Figure 5-86 Convergence Point Array
S2180 W1120 – Roof to Floor



**Figure 5-87 Convergence Point Array
S2180 W1190 Intersection (Room 7, Panel 7) – Roof to Floor**



**Figure 5-88 Convergence Point Array
Room 1, Panel 7 at W390 S2275 – Roof to Floor**

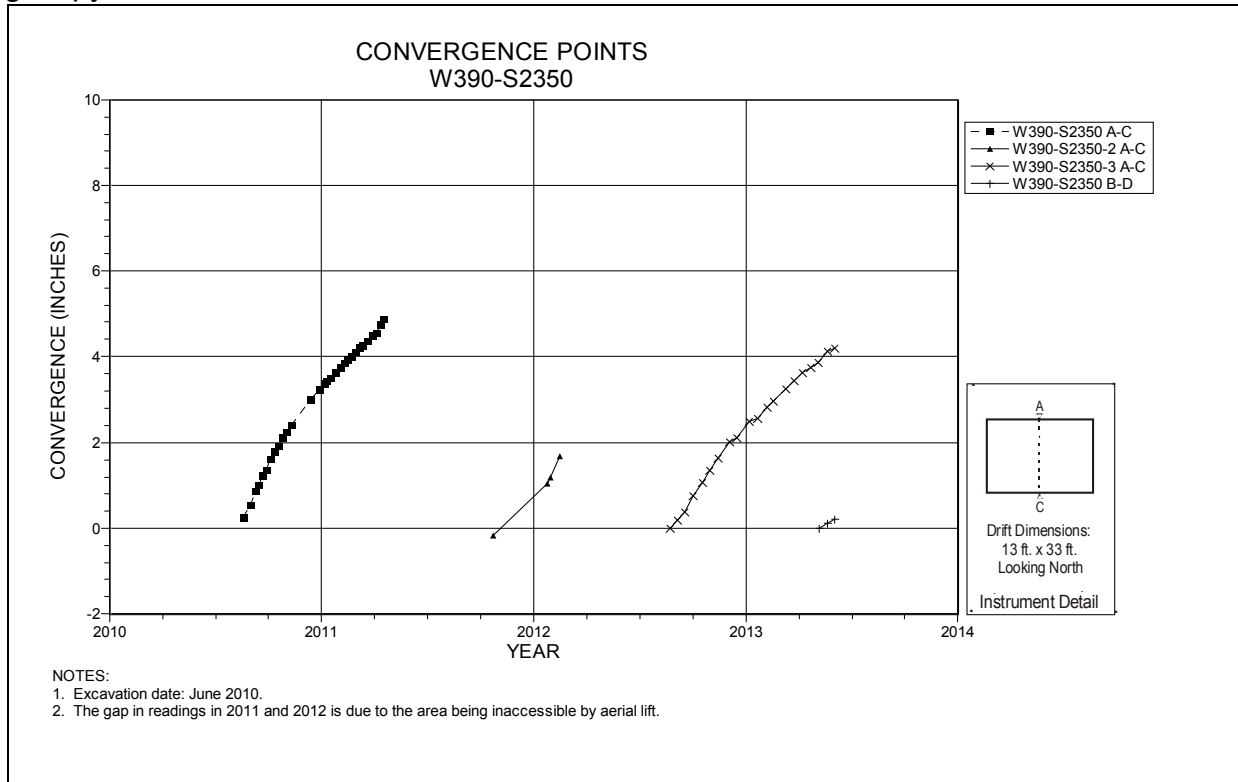

**Figure 5-89 Convergence Point Array
Room 1, Panel 7 at W390 S2350– Room Center – All Chords**

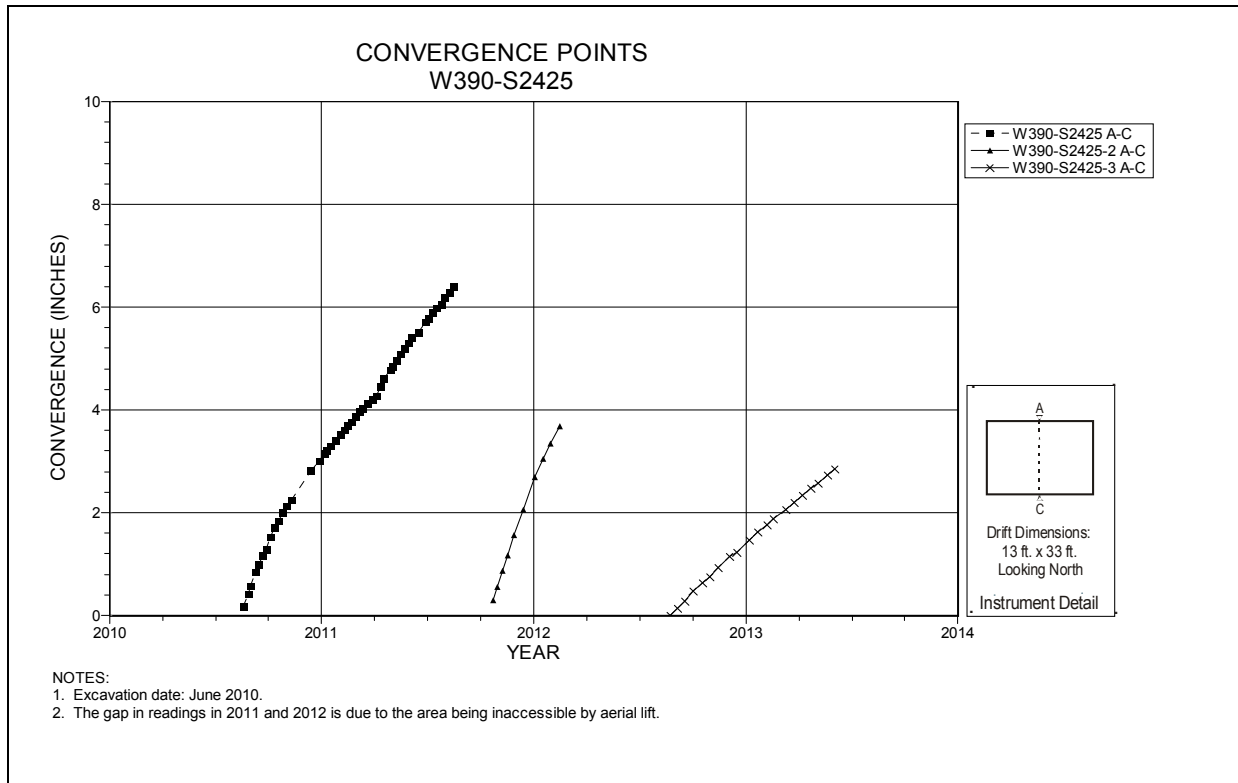

**Figure 5-90 Convergence Point Array
Room 1, Panel 7 at W390 S2425 – Roof to Floor**

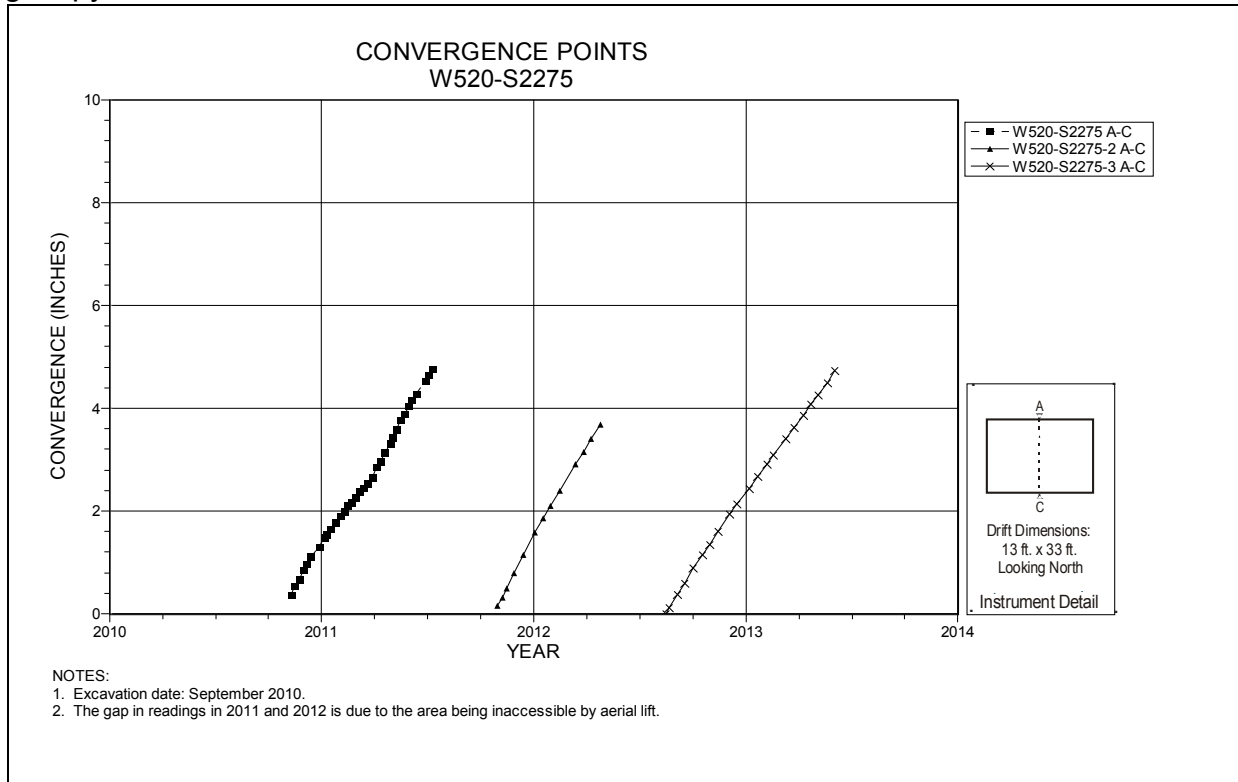

**Figure 5-91 Convergence Point Array
Room 2, Panel 7 at W520 S2275 – Roof to Floor**

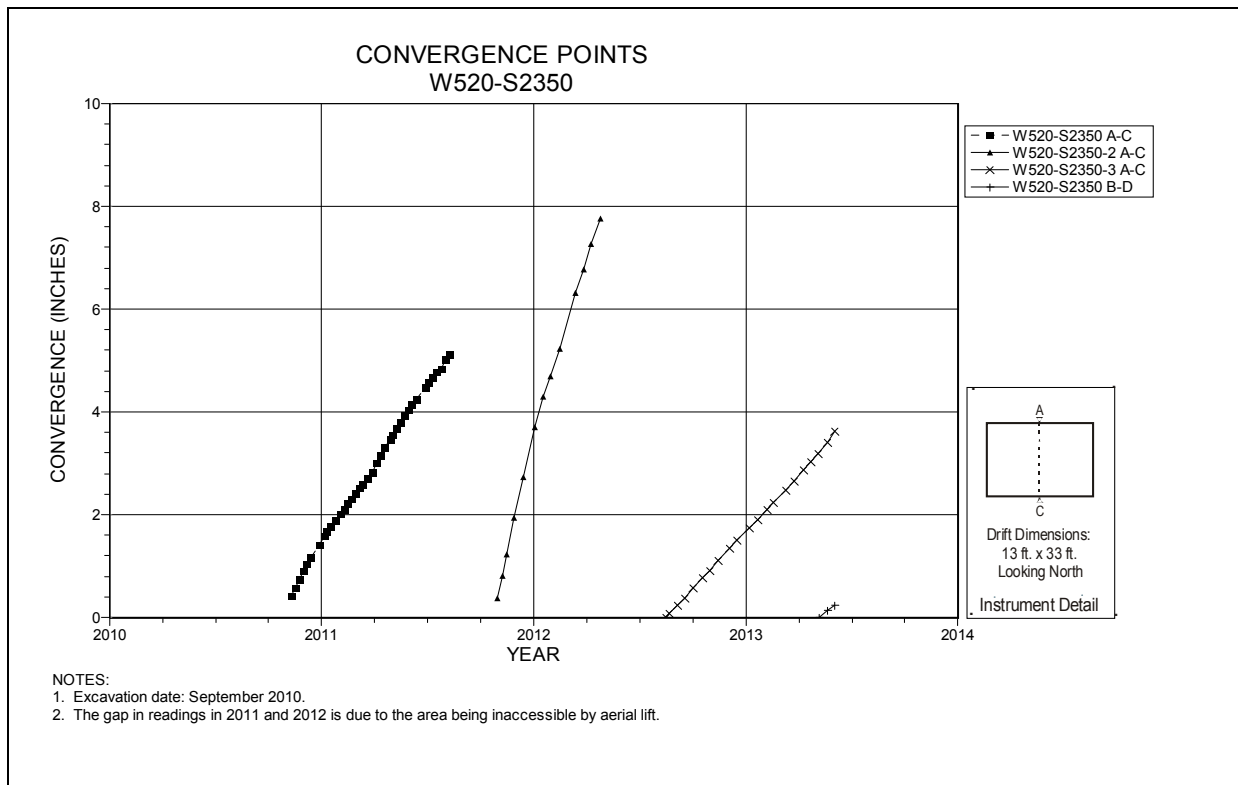

**Figure 5-92 Convergence Point Array
Room 2, Panel 7 at W520 S2350 – Room Center – All Chords**

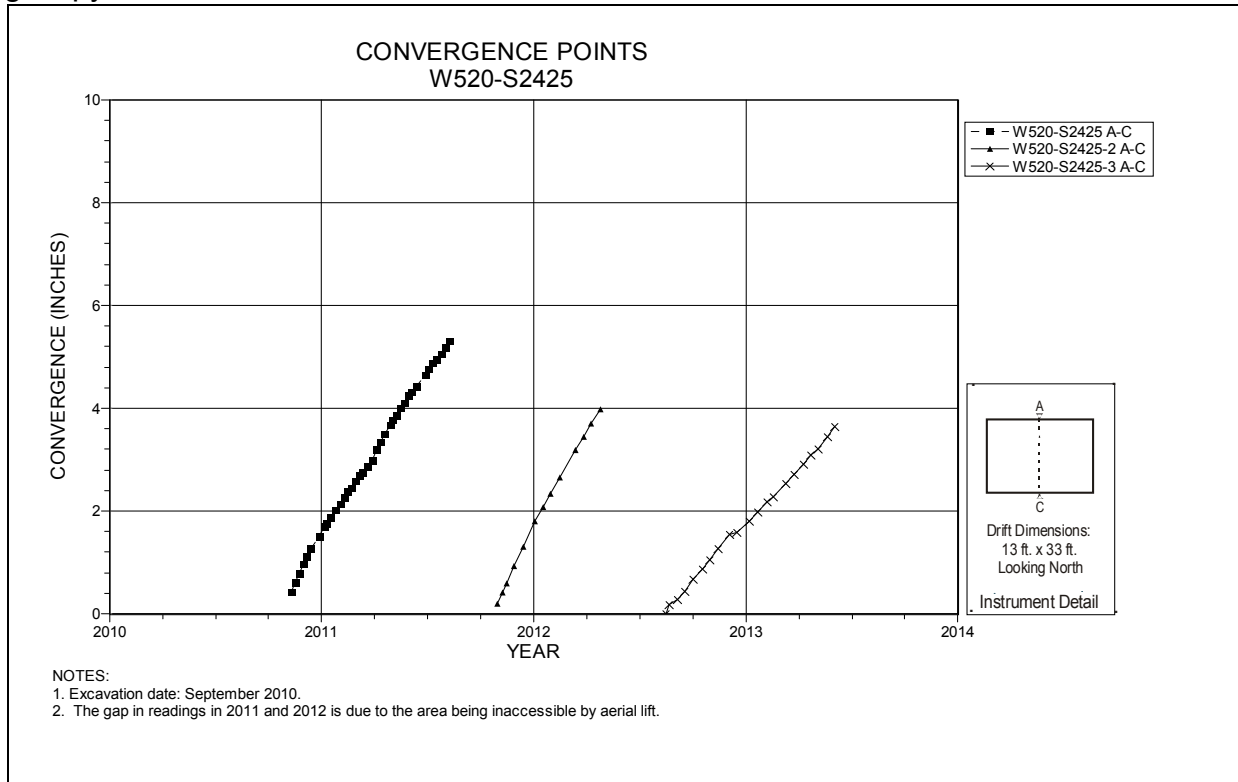

**Figure 5-93 Convergence Point Array
Room 2, Panel 7 at W520 S2425 – Roof to Floor**

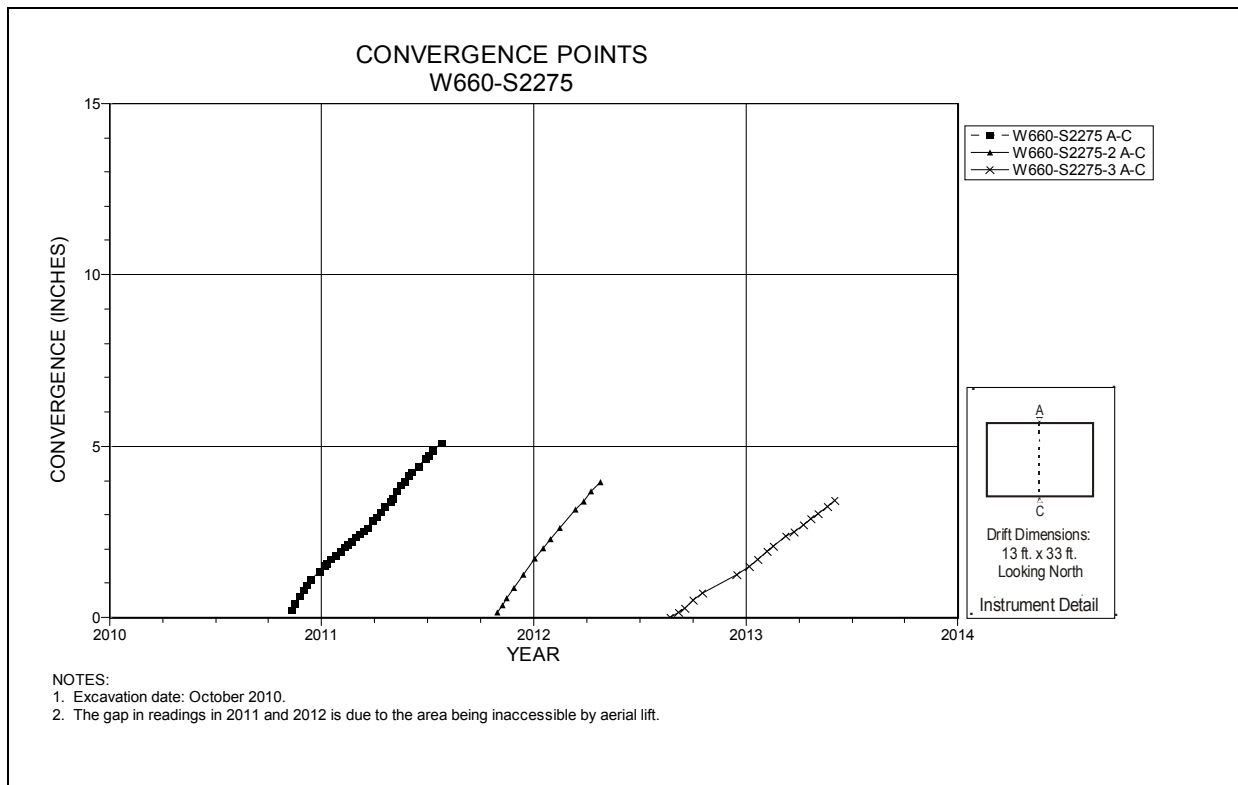

**Figure 5-94 Convergence Point Array
Room 3, Panel 7 at W660 S2275 – Roof to Floor**

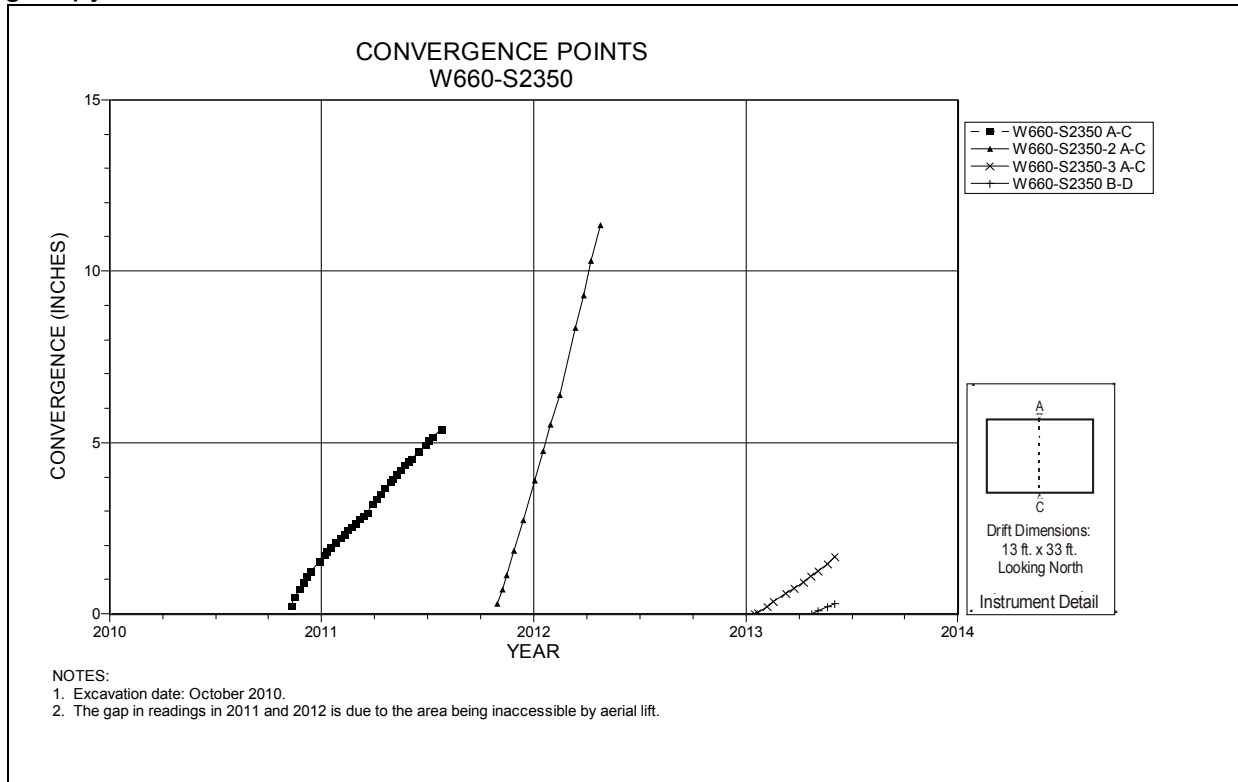

Figure 5-95 Convergence Point Array
Room 3, Panel 7 at W660 S2350 – Room Center – All Chords

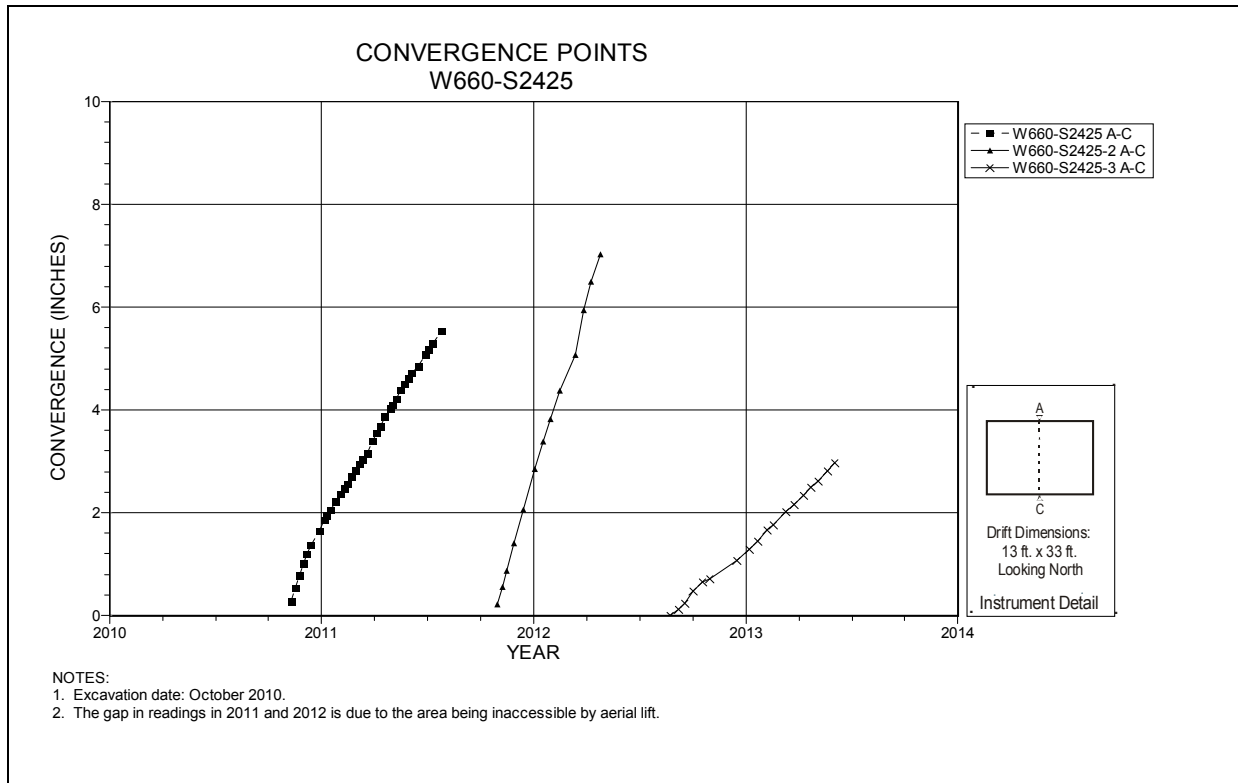
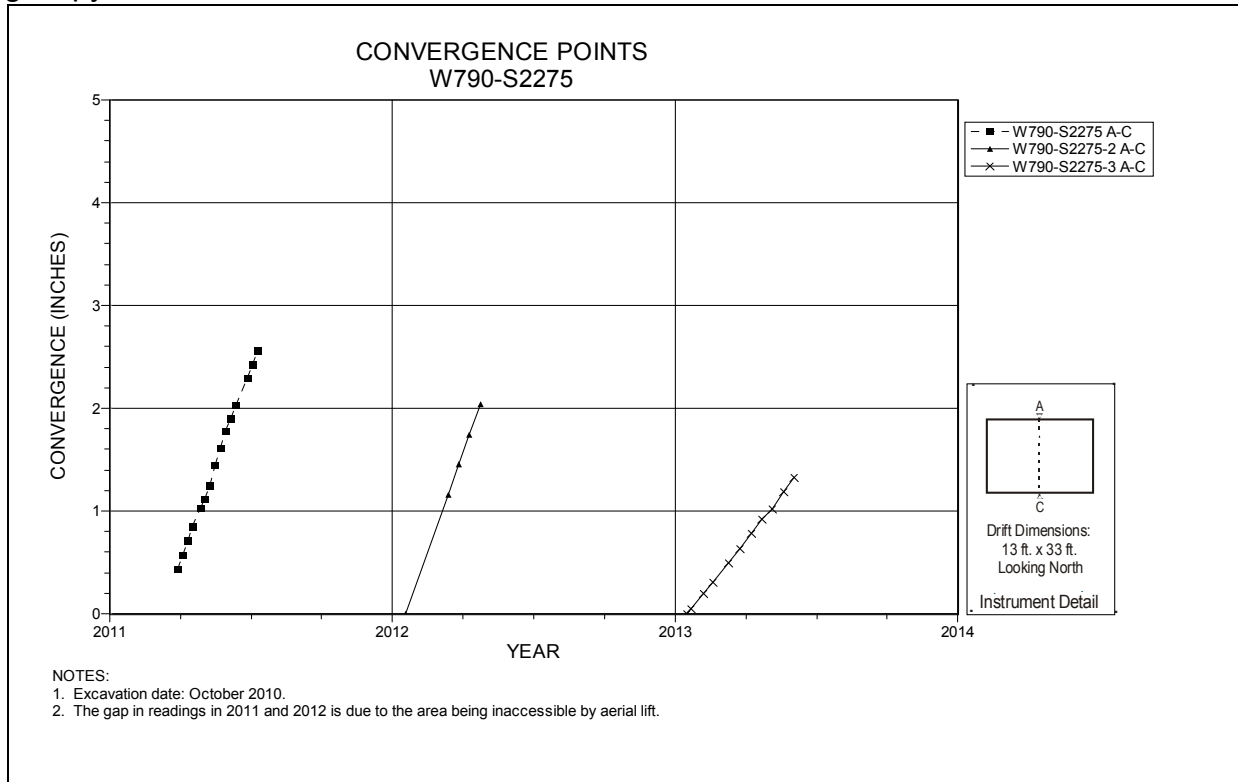
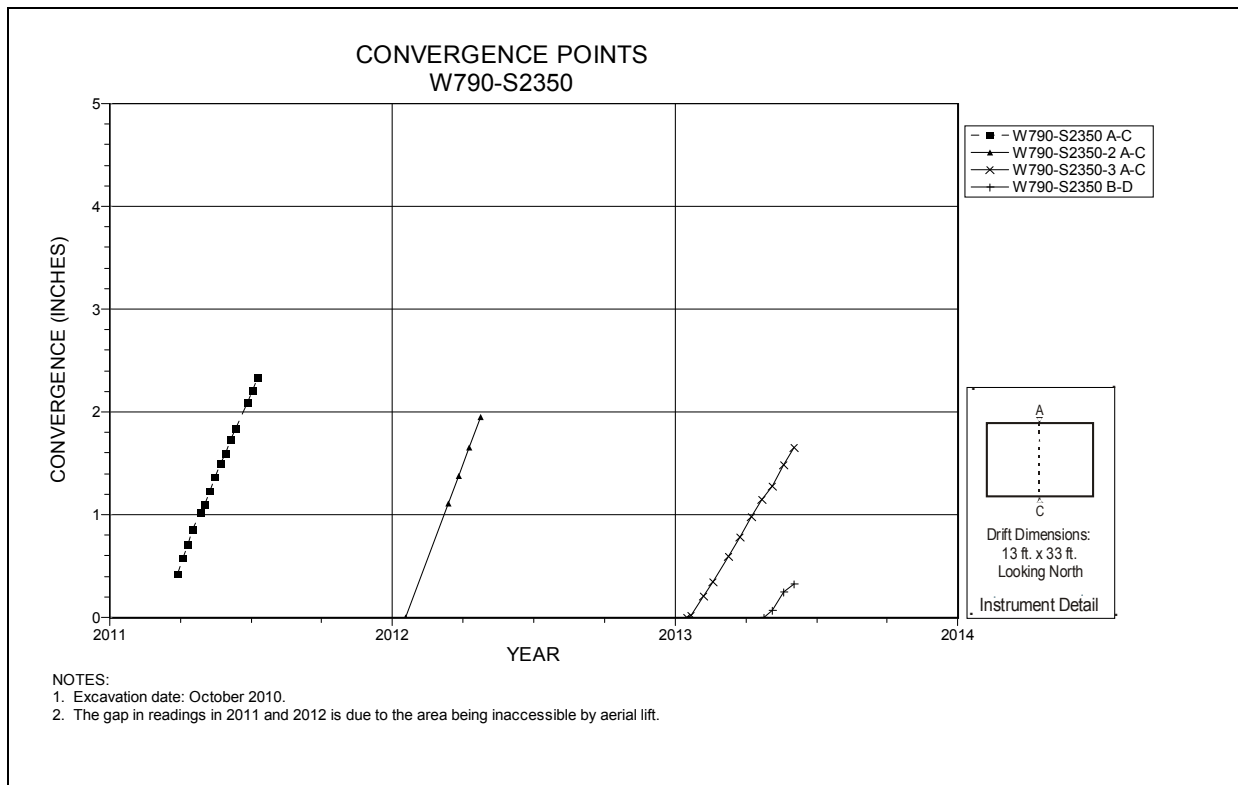

Figure 5-96 Convergence Point Array
Room 3, Panel 7 at W660 S2425 – Roof to Floor



**Figure 5-97 Convergence Point Array
Room 4, Panel 7 at W790 S2275 – Roof to Floor**



**Figure 5-98 Convergence Point Array
Room 4, Panel 7 at W790 S2350 – Room Center – All Chords**

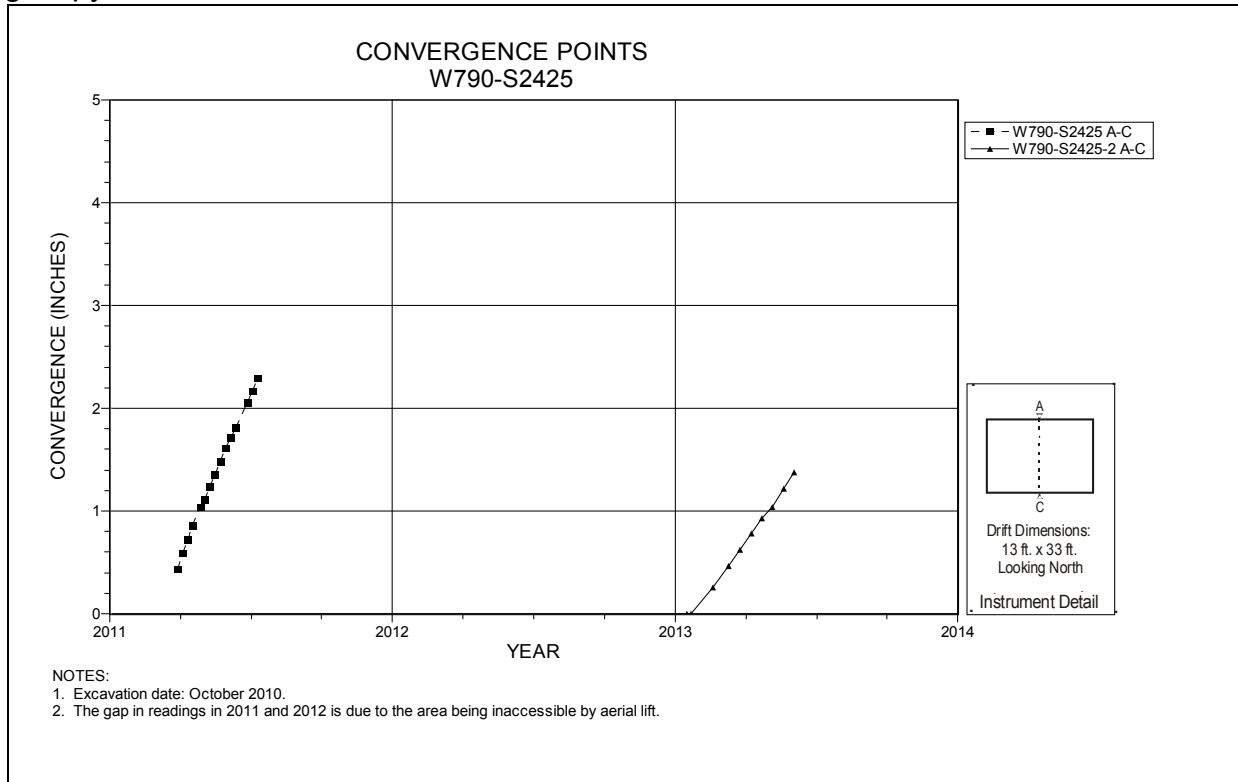

**Figure 5-99 Convergence Point Array
Room 4, Panel 7 at W790 S2425 – Roof to Floor**

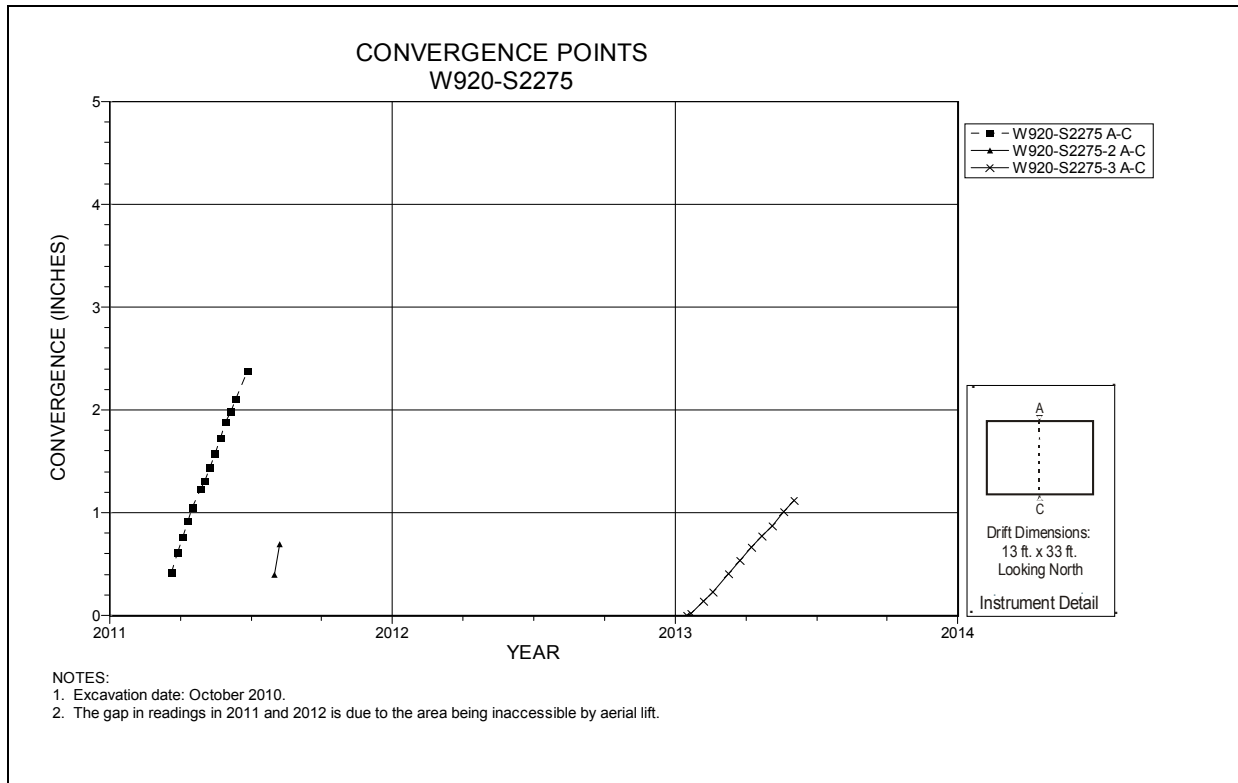

**Figure 5-100 Convergence Point Array
Room 5, Panel 7 at W920 S2275 – Roof to Floor**

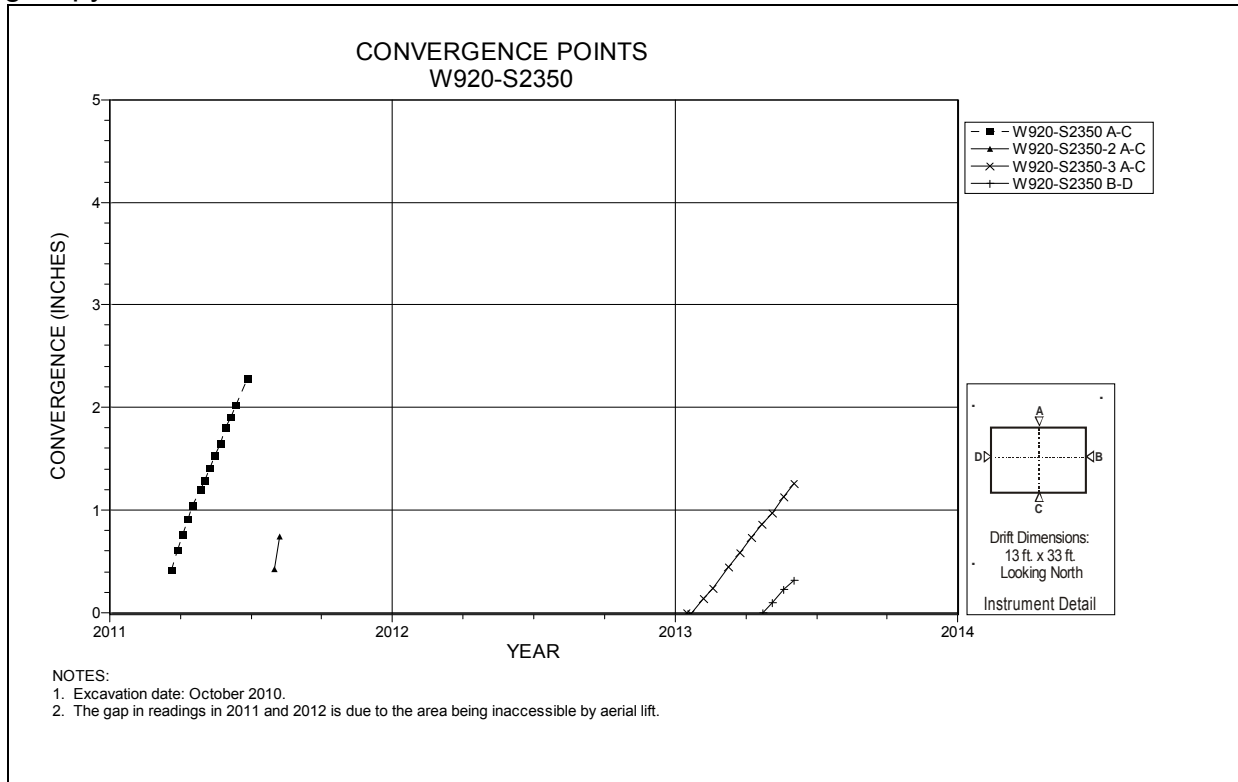

**Figure 5-101 Convergence Point Array
Room 5, Panel 7 at W920 S2350 – Room Center – All Chords**

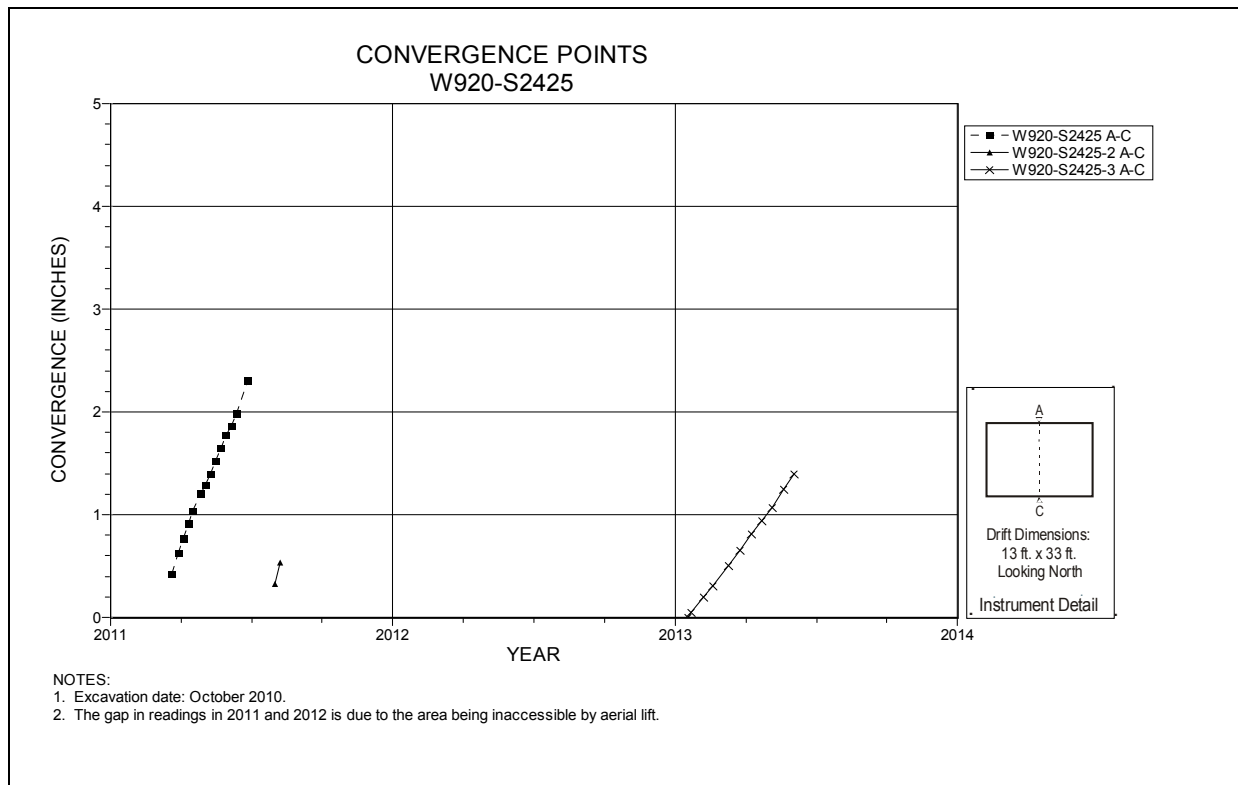

**Figure 5-102 Convergence Point Array
Room 5, Panel 7 at W920 S2425 – Roof to Floor**

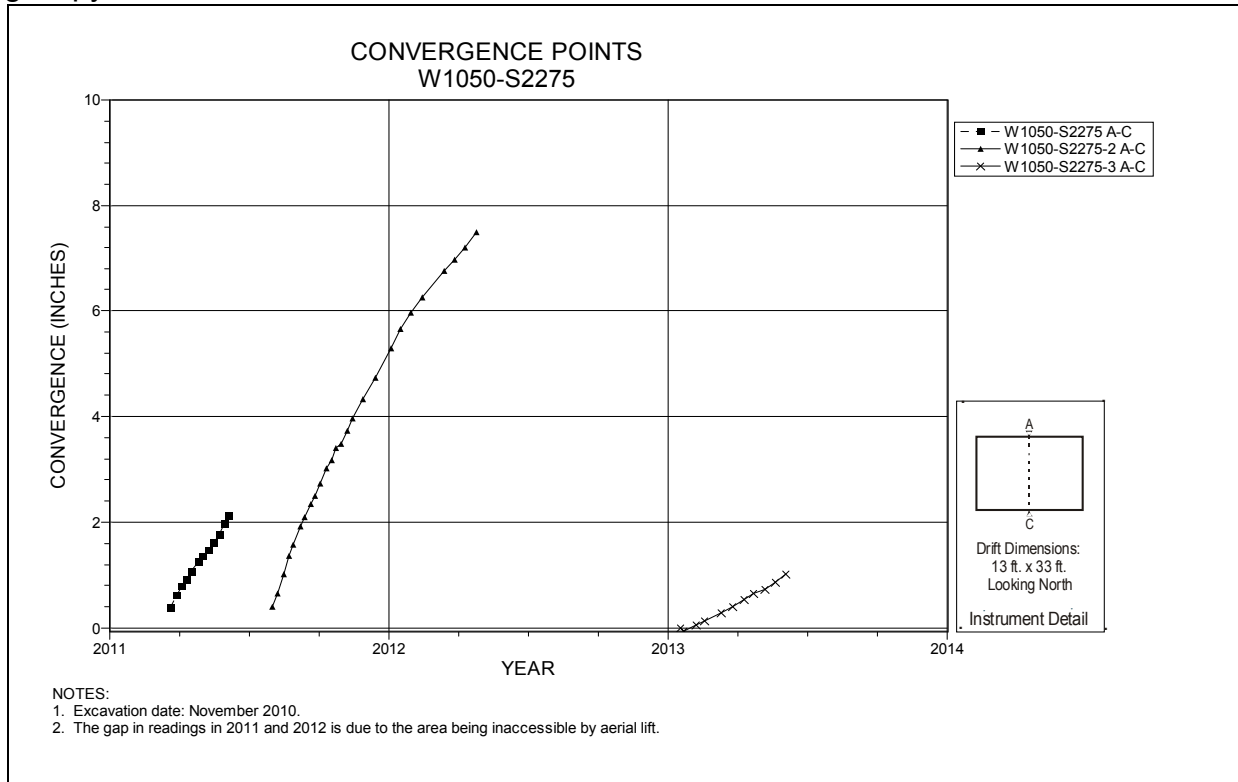

**Figure 5-103 Convergence Point Array
Room 6, Panel 7 at W1050 S2275 – Roof to Floor**

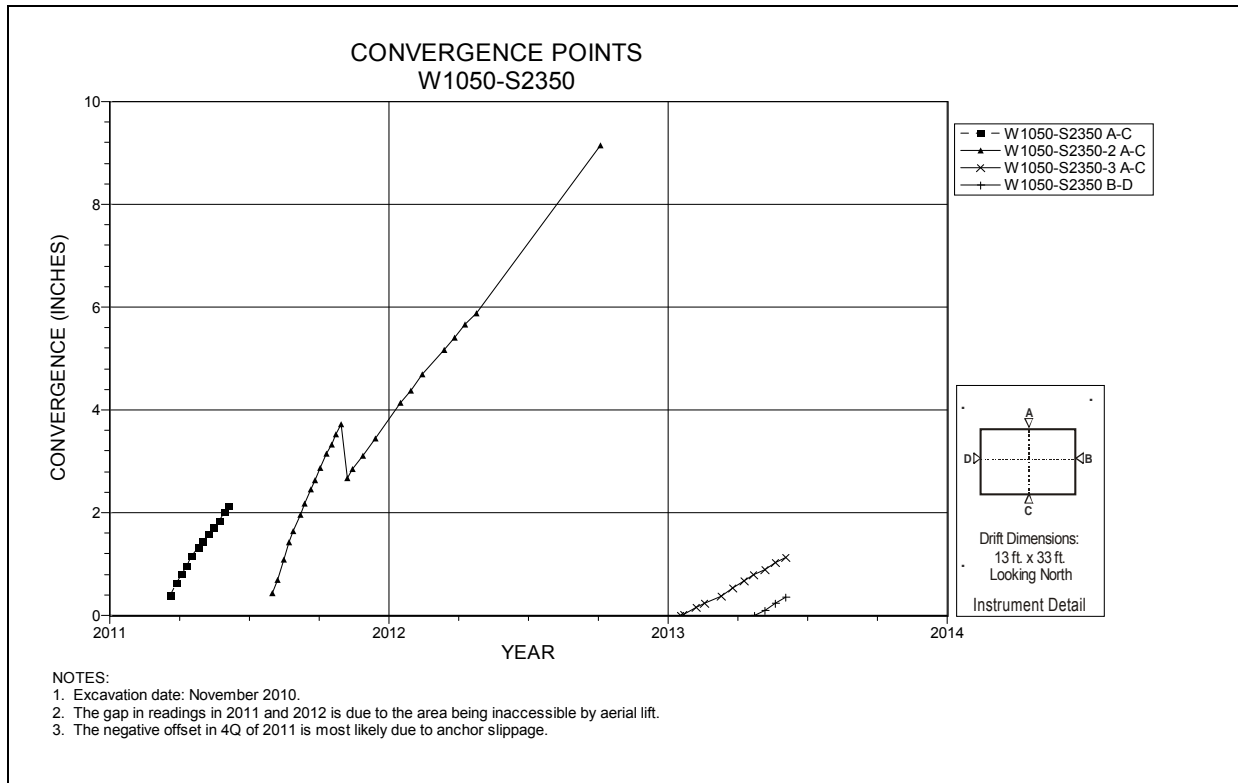

**Figure 5-104 Convergence Point Array
Room 6, Panel 7 at W1050 S2350 – Room Center – All Chords**

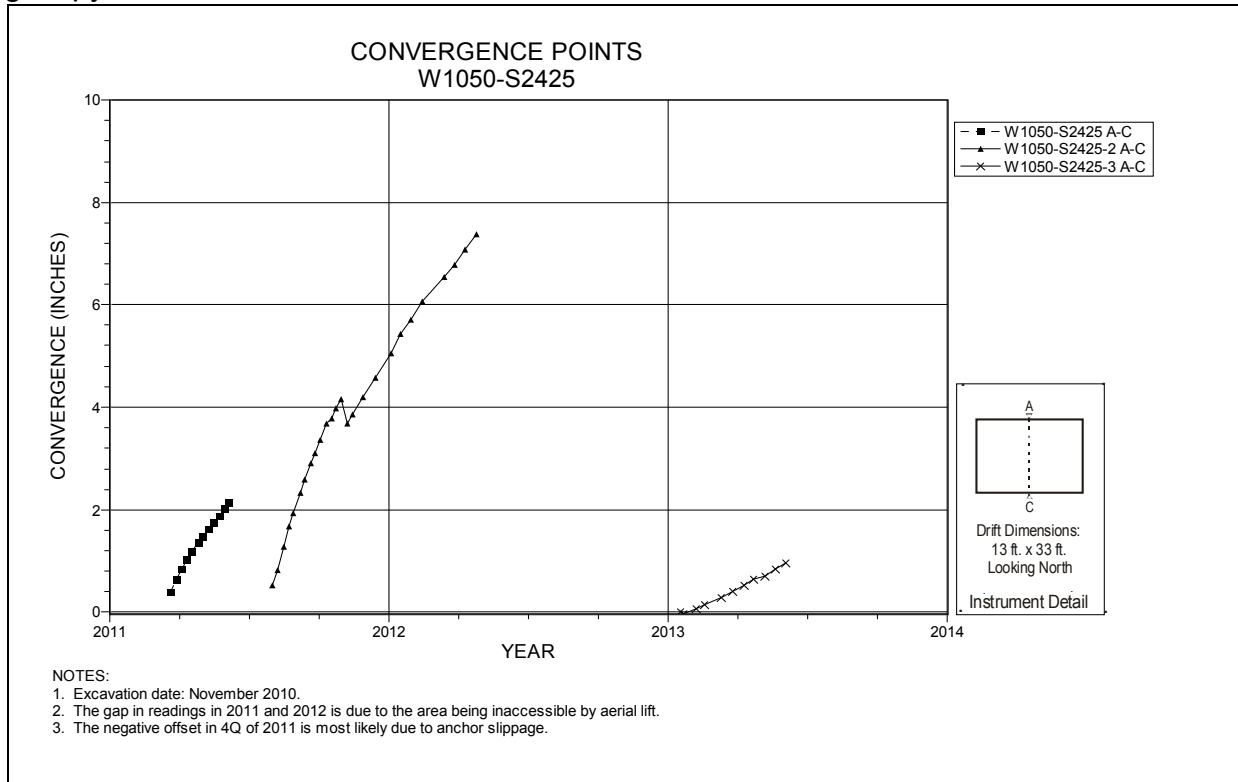

**Figure 5-105 Convergence Point Array
Room 6, Panel 7 at W1050 S2425 – Roof to Floor**

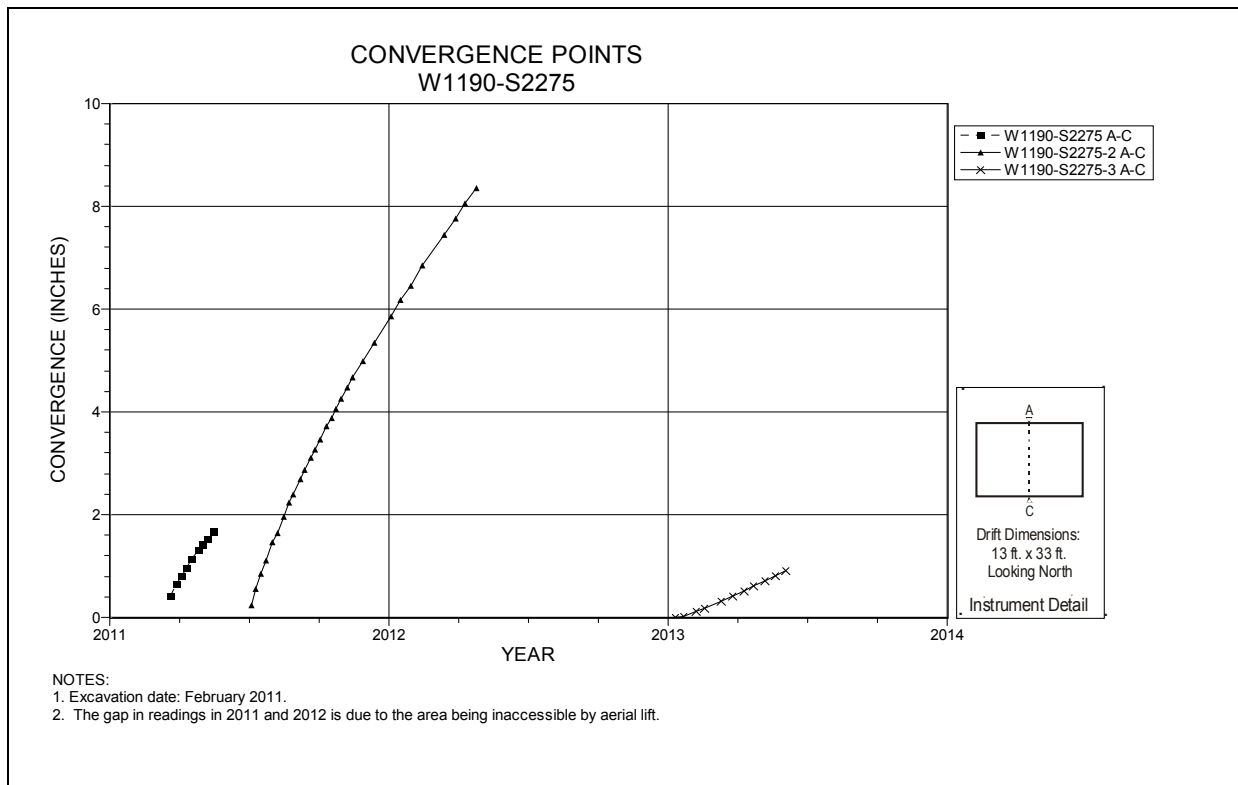

**Figure 5-106 Convergence Point Array
Room 7, Panel 7 at W1190 S2275 – Roof to Floor**

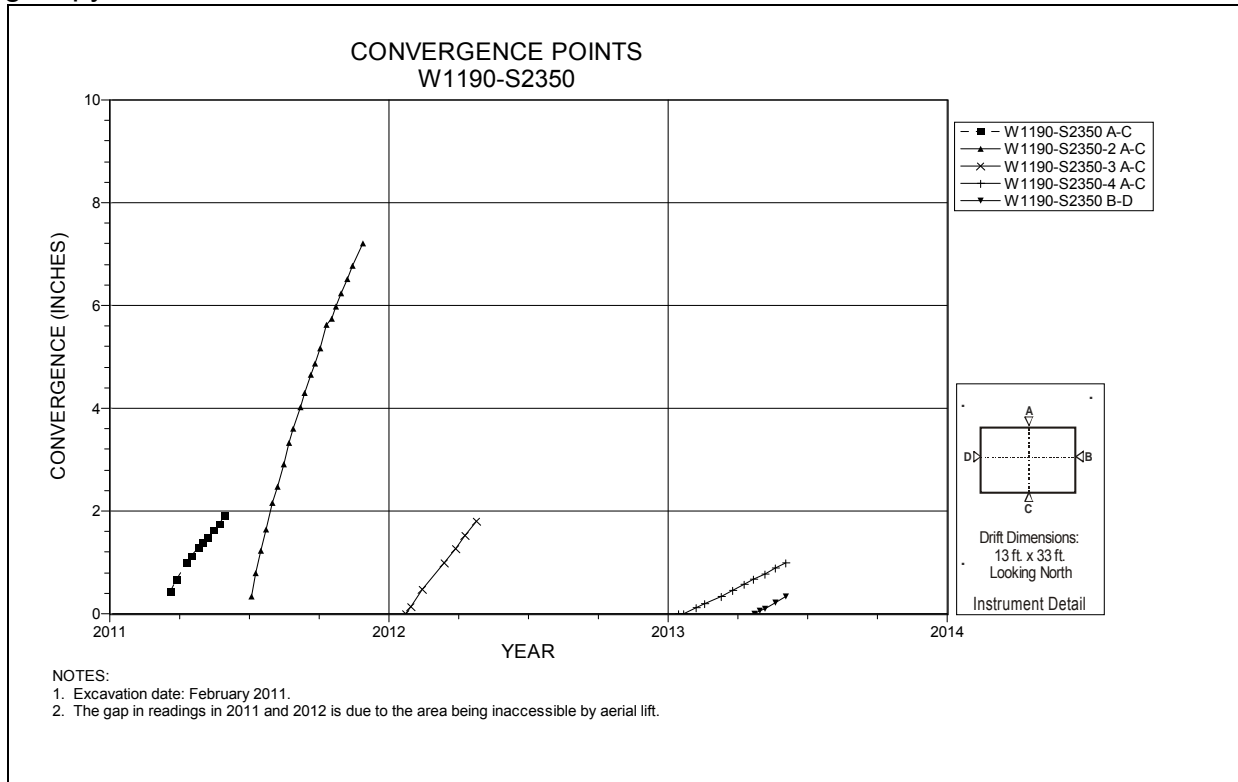

**Figure 5-107 Convergence Point Array
Room 7, Panel 7 at W1190 S2350 – Room Center – All Chords**

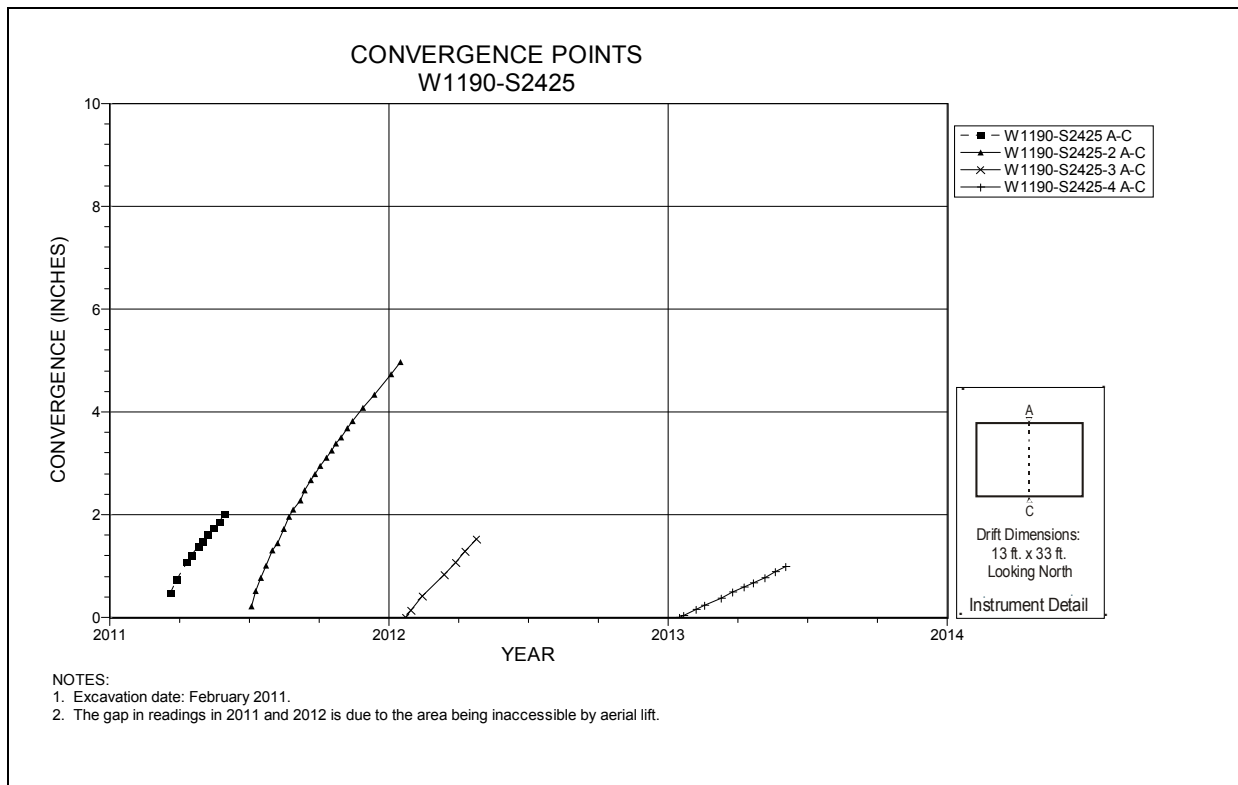

**Figure 5-108 Convergence Point Array
Room 7, Panel 7 at W1190 S2425 – Roof to Floor**

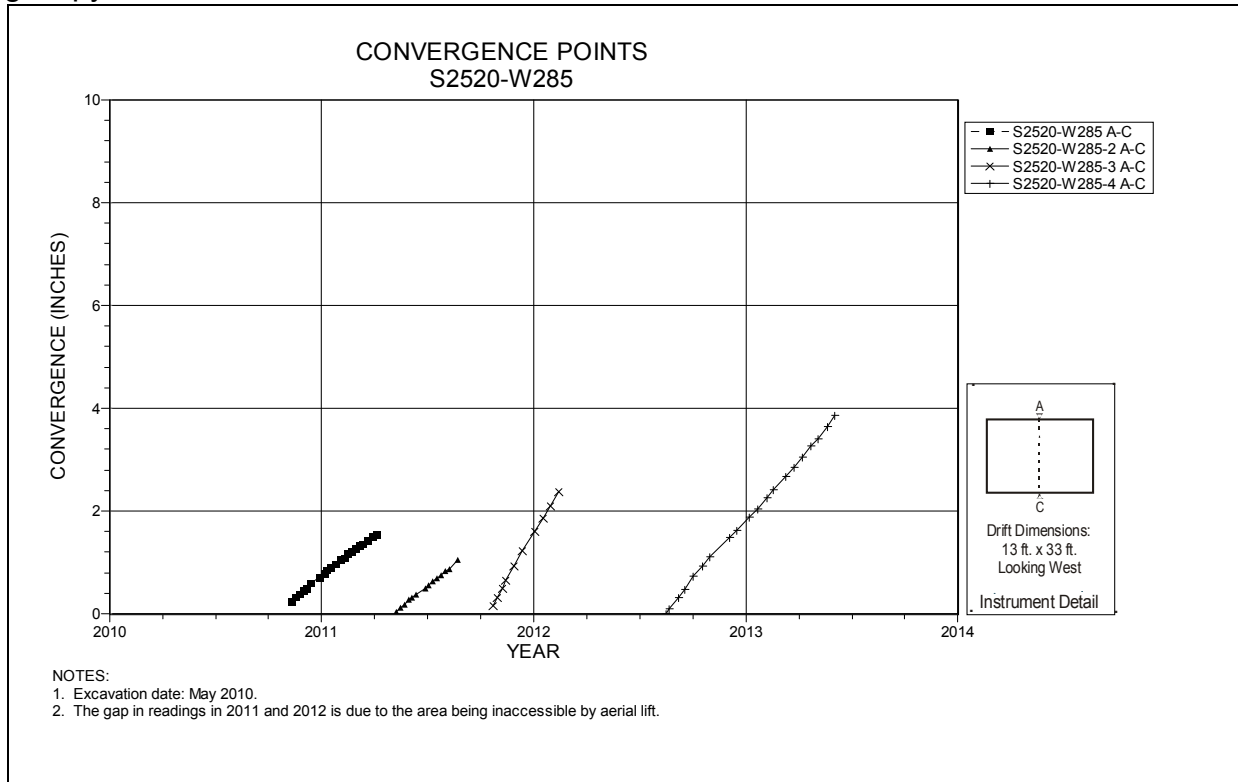

Figure 5-109 Convergence Point Array
S2520 W285 – Roof to Floor

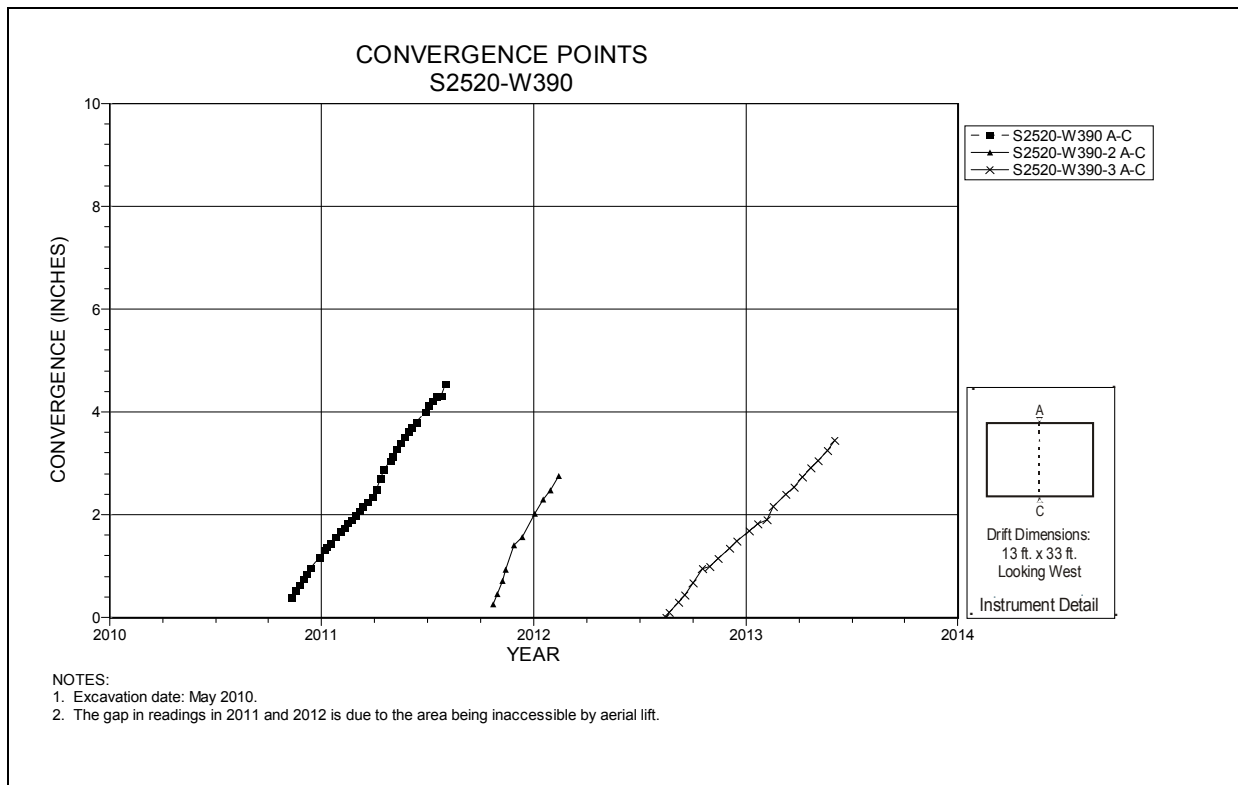

Figure 5-110 Convergence Point Array
S2520 W390 Intersection (Room 1, Panel 7) – Roof to Floor

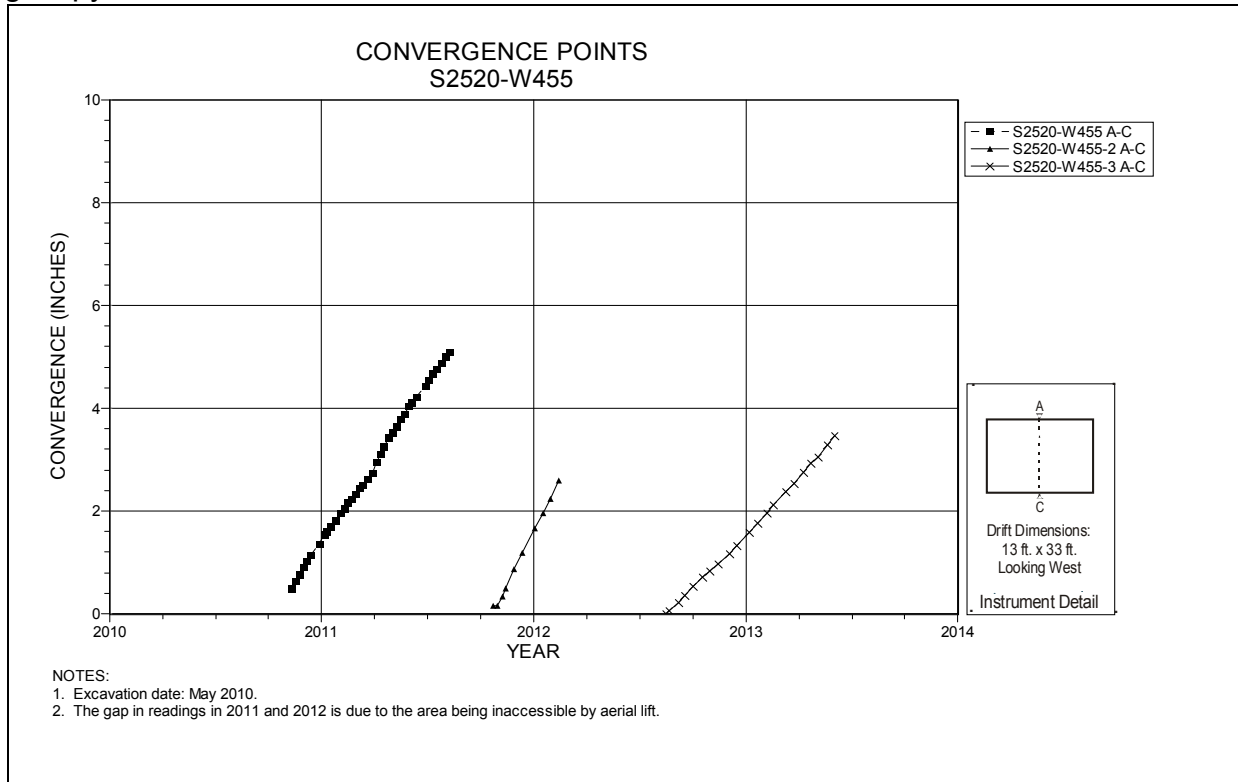

Figure 5-111 Convergence Point Array
S2520 W455 – Roof to Floor

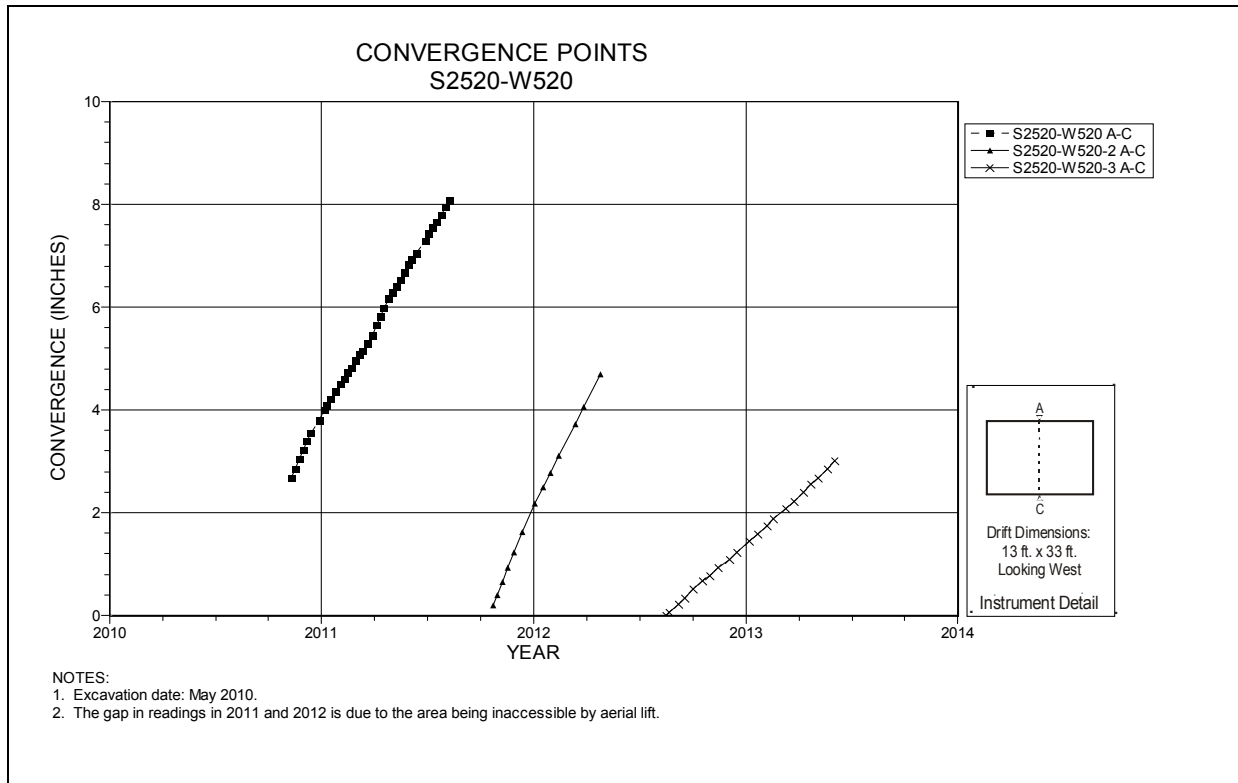

Figure 5-112 Convergence Point Array
S2520 W520 Intersection (Room 2, Panel 7) – Roof to Floor

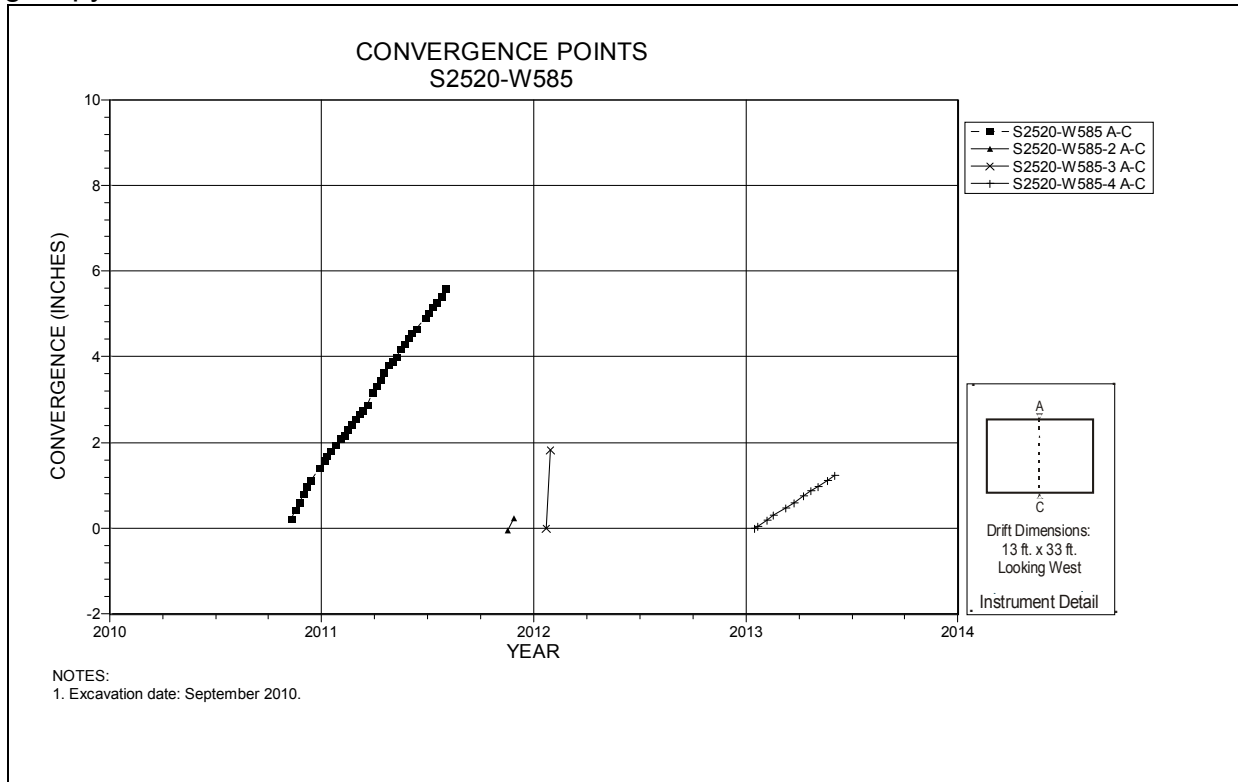

Figure 5-113 Convergence Point Array
S2520 W585 – Roof to Floor

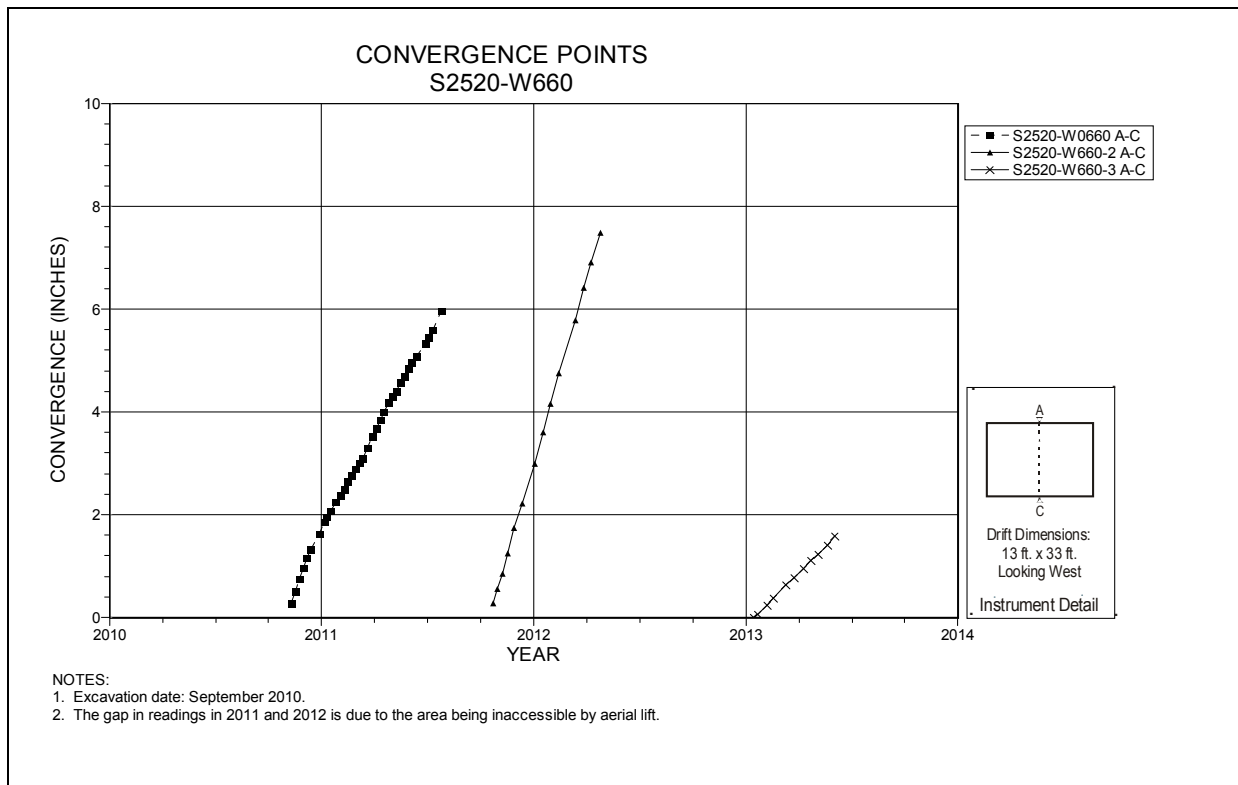

Figure 5-114 Convergence Point Array
S2520 W660 Intersection (Room 3, Panel 7) – Roof to Floor

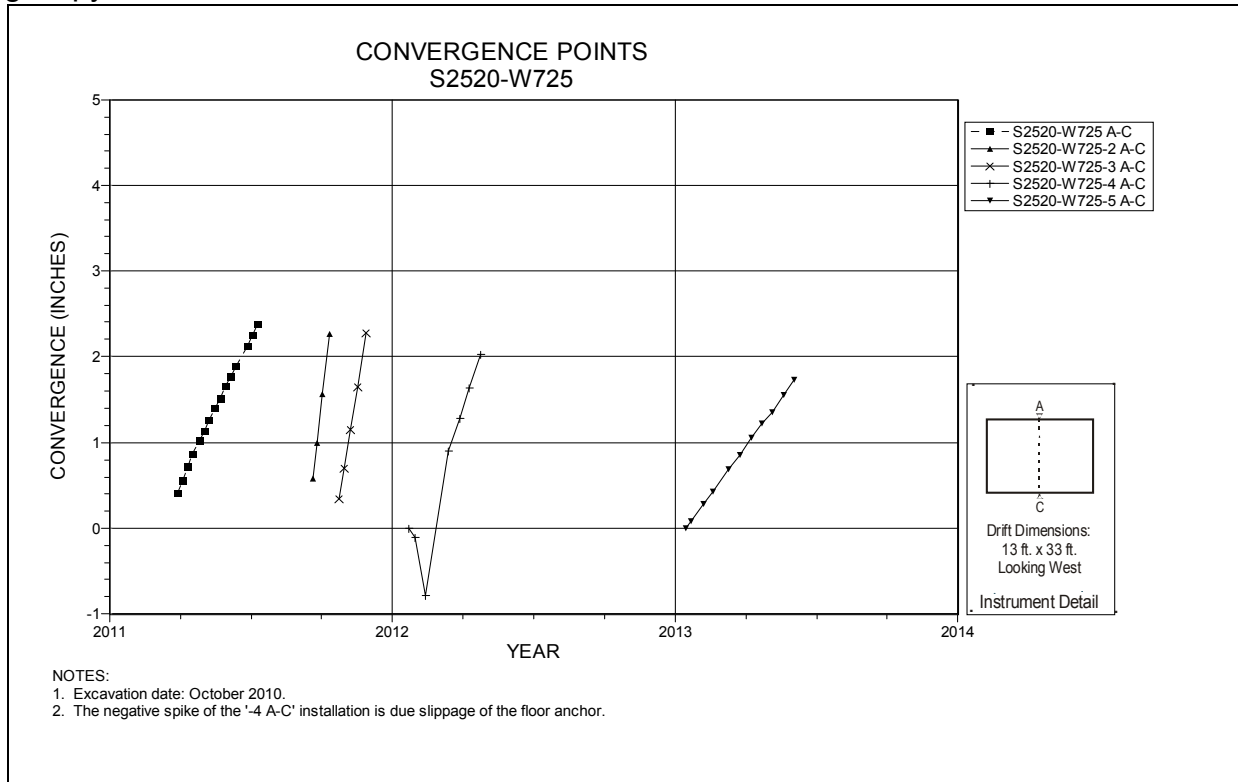

Figure 5-115 Convergence Point Array
S2520 W725 – Roof to Floor

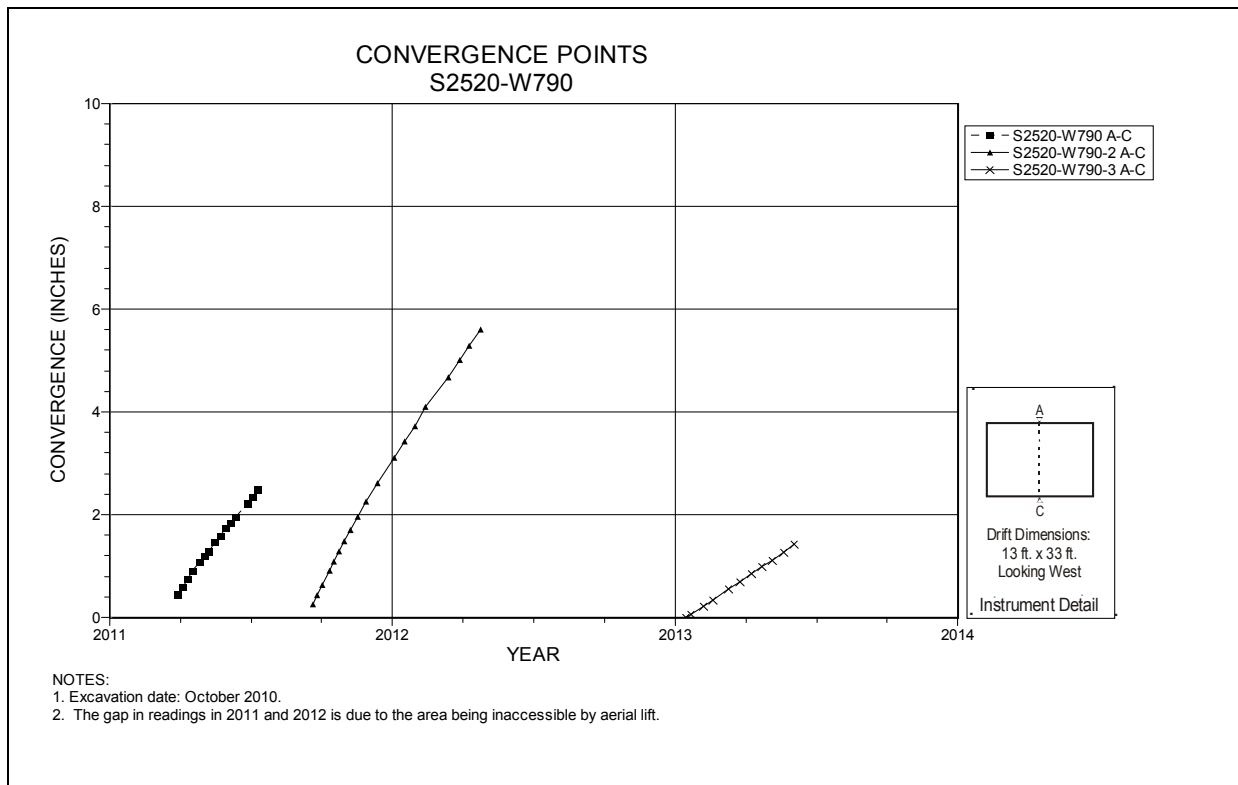
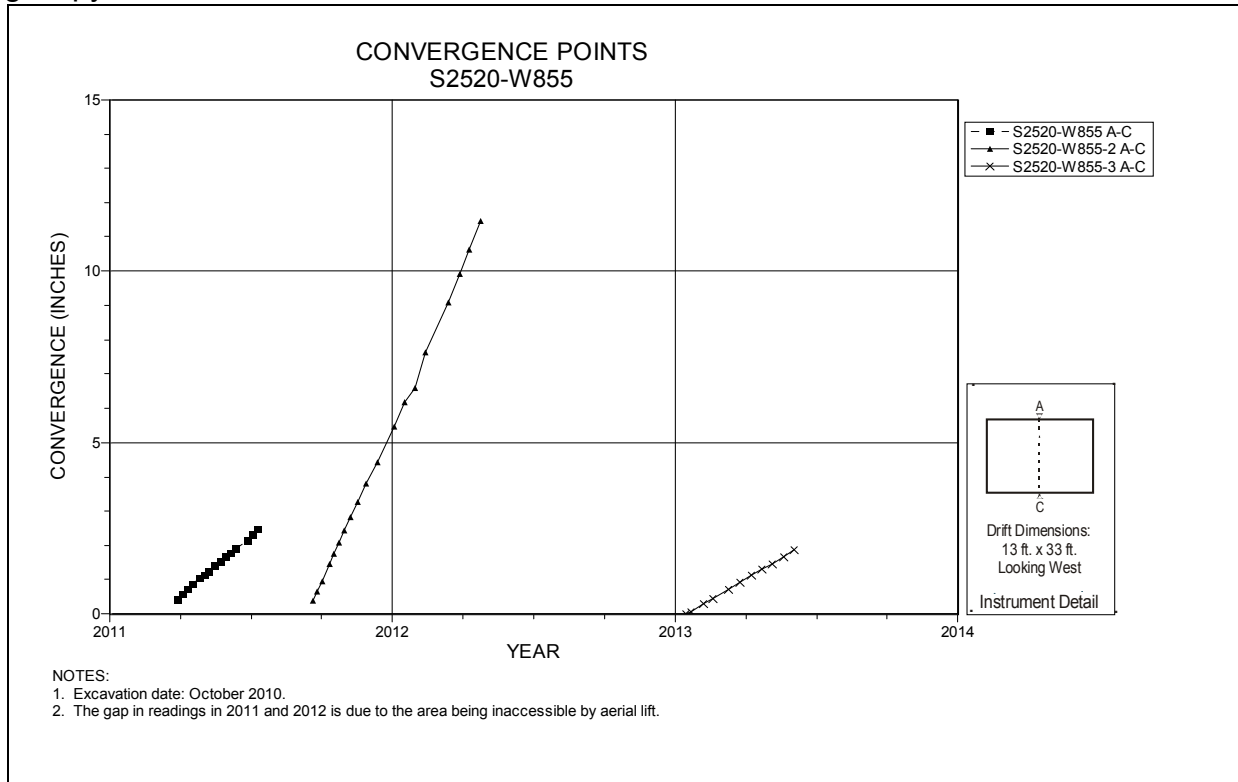
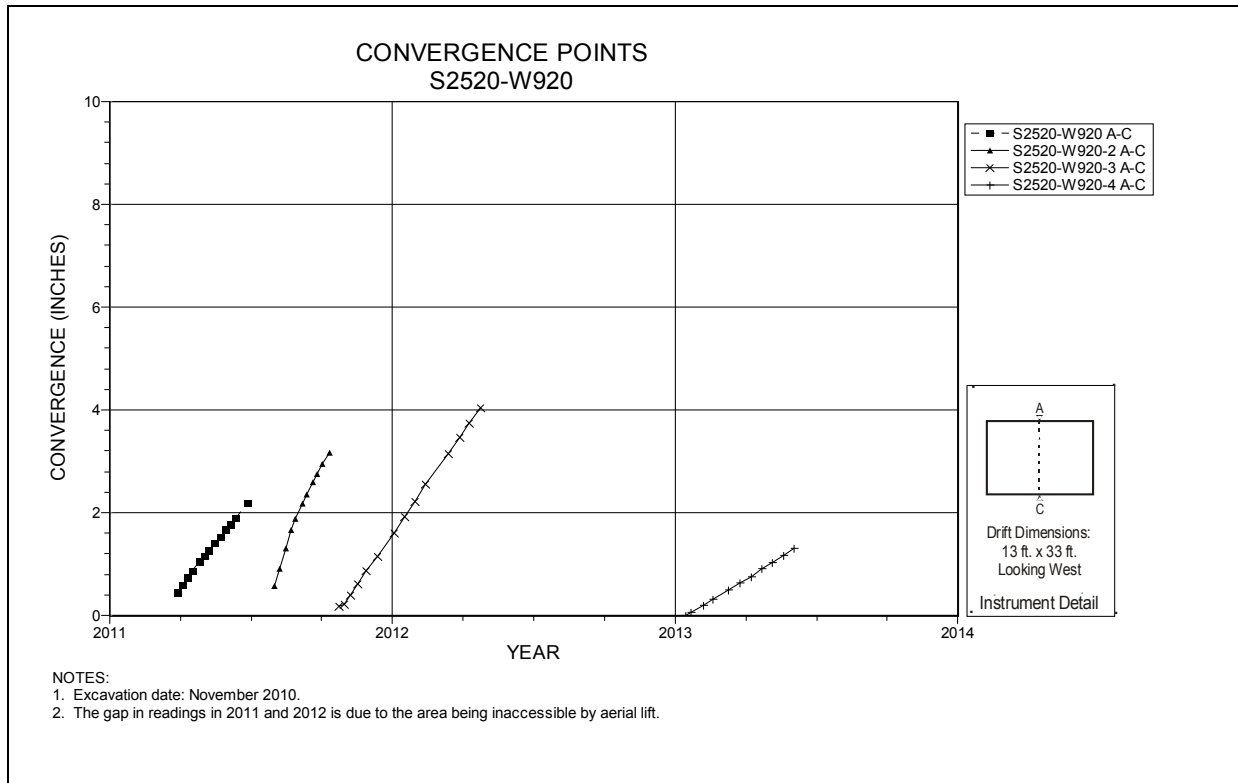

Figure 5-116 Convergence Point Array
S2520 W790 Intersection (Room 4, Panel 7) – Roof to Floor



**Figure 5-117 Convergence Point Array
S2520 W855 – Roof to Floor**



**Figure 5-118 Convergence Point Array
S2520 W920 Intersection (Room 5, Panel 7) – Roof to Floor**

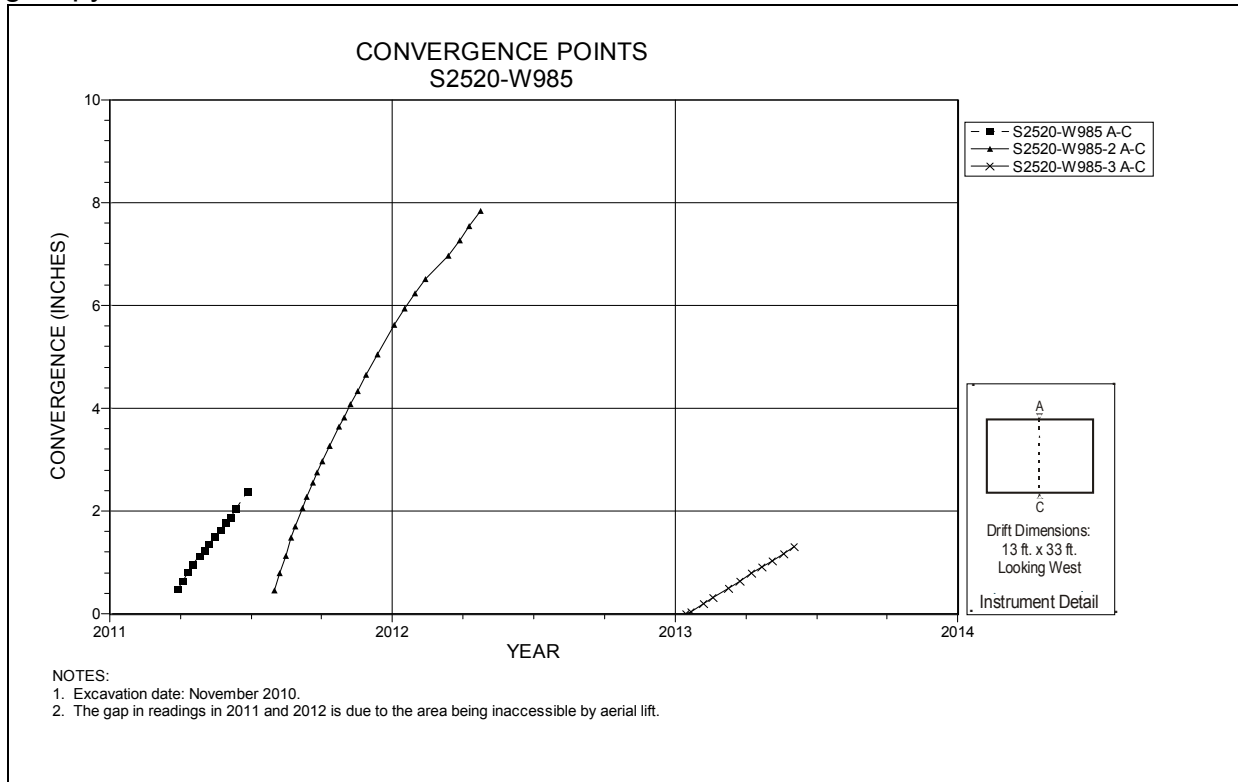

**Figure 5-119 Convergence Point Array
S2520 W985 – Roof to Floor**

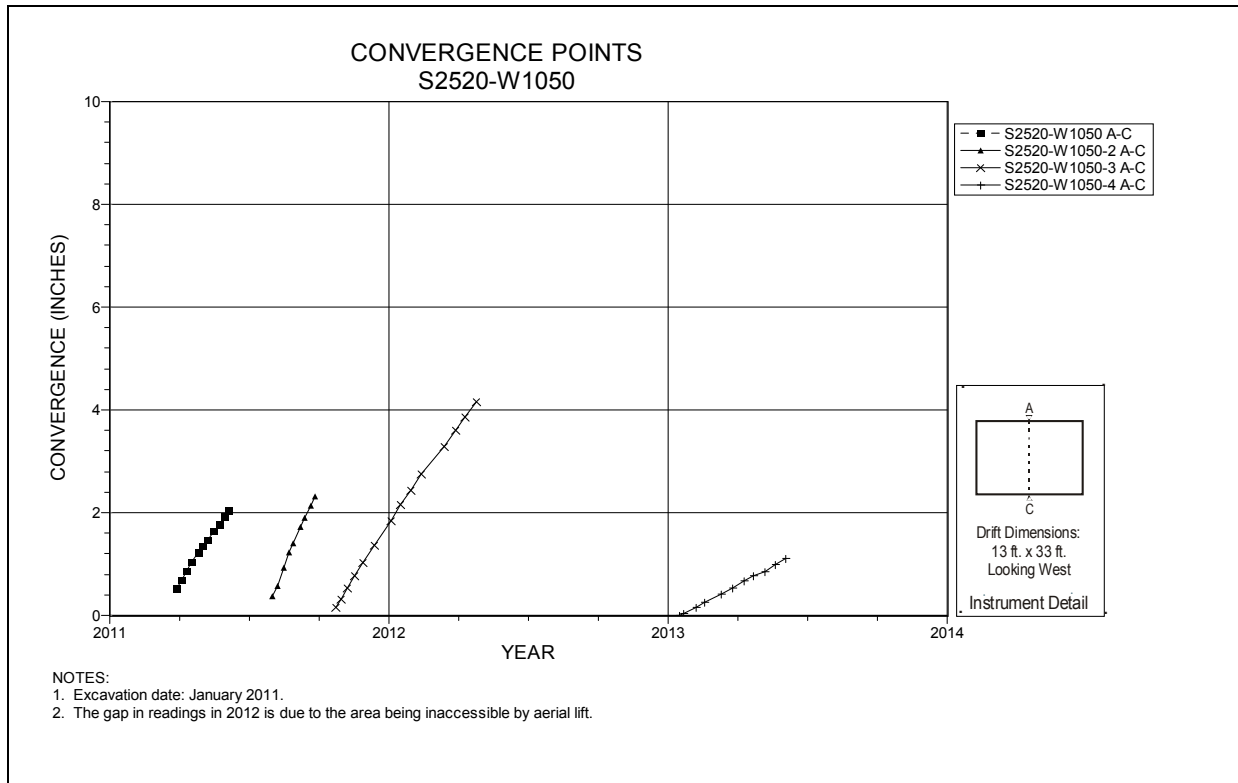

**Figure 5-120 Convergence Point Array
S2520 W1050 Intersection (Room 6, Panel 7) – Roof to Floor**

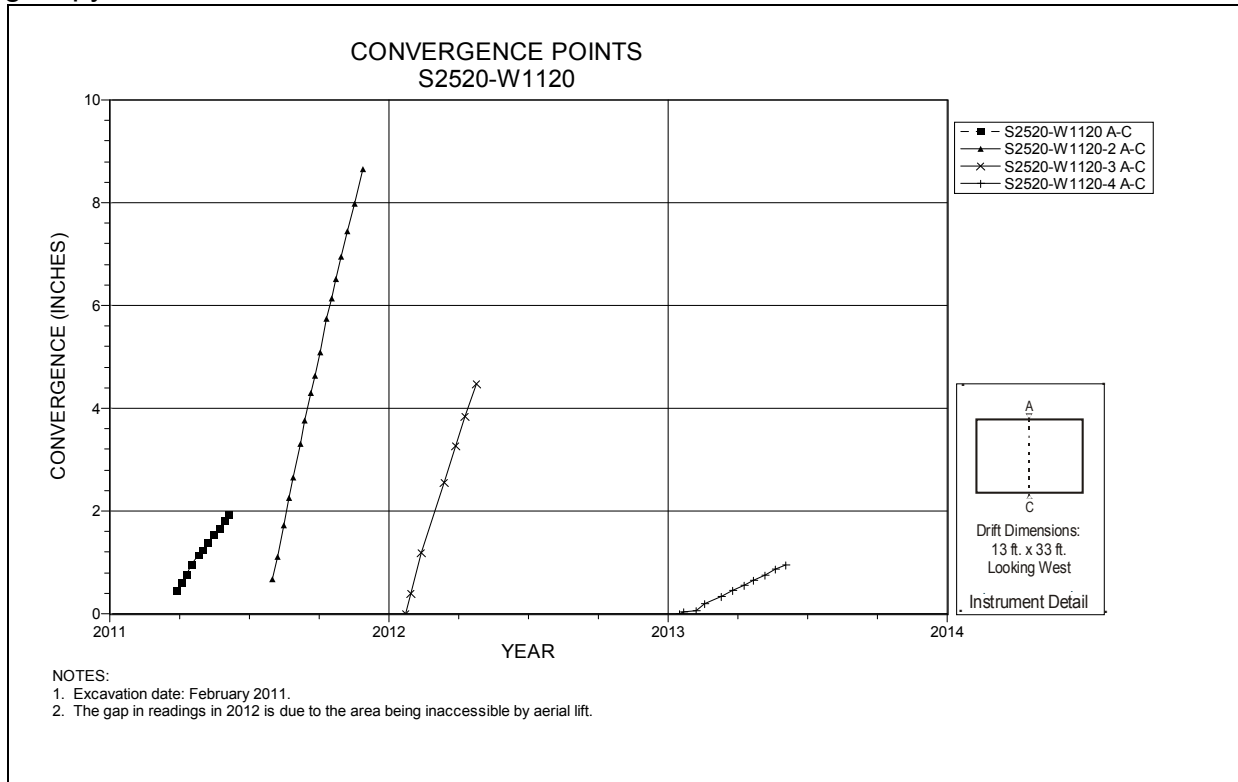

Figure 5-121 Convergence Point Array
S2520 W1120 – Roof to Floor

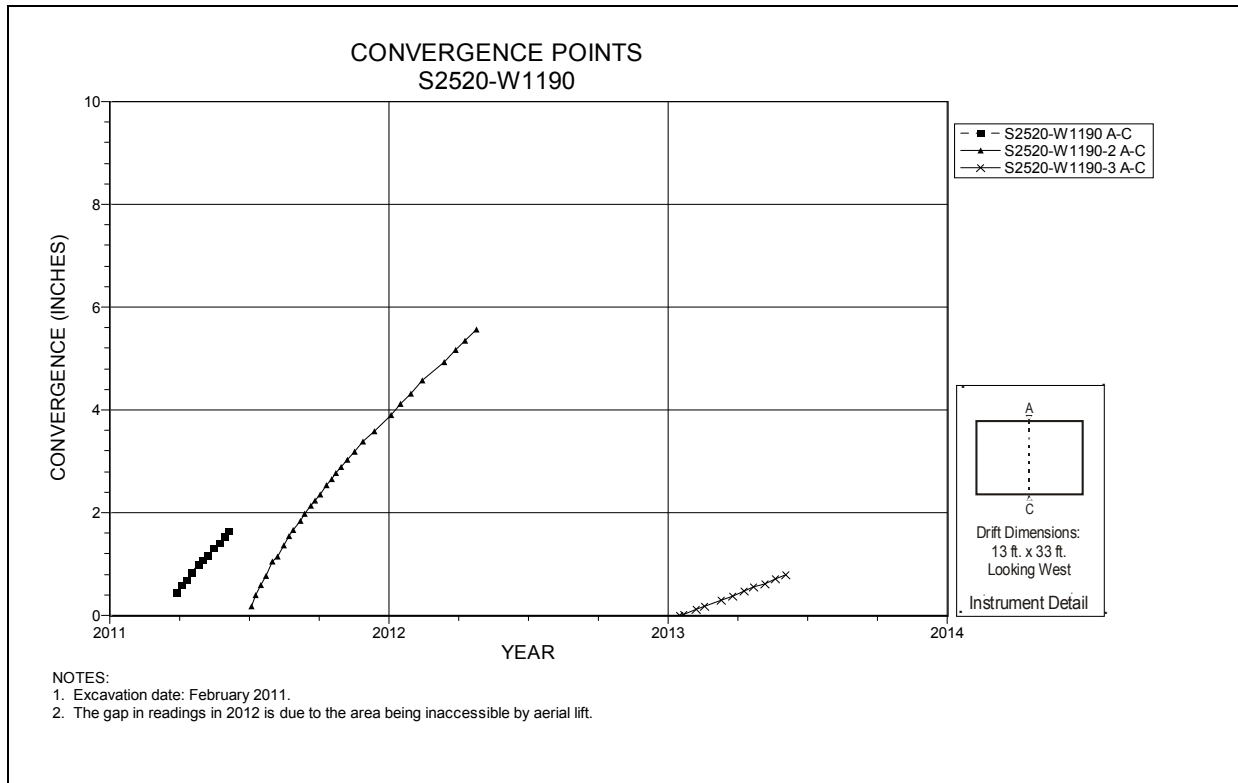

Figure 5-122 Convergence Point Array
S2520 W1190 Intersection (Room 7, Panel 7) – Roof to Floor

This page was intentionally left blank.

6.0 Instrumentation Summary for the SDI Area

This chapter presents a summary of the data collected from radial convergence points located in the Storage Disposal Investigations (SDI) area at the WIPP. Table 6-1 presents data and analysis of the access drifts associated with the SDI area. Plots of the instrument data are presented as Figures 6-1 through 6-46.

Radial convergence points have been installed at the pillar midpoints, quarter points and drift intersections. The SDI area is still being mined. Hence, at times, access to many of the instruments may not be possible. Therefore, there will be intervals on some of the data plots void of any readings. Readings are resumed once access has been restored.

Table 6-1
SDI Data Analysis

Convergence Points									
Field Tag	Location	Figure Number	Last Reading 2012 to 2013		Cumulative Displacement (inches)	Closure Rate 2012 to 2013 (in/year)	Closure Rate ¹ 2011 to 2012 (in/year)	Rate Change Percent ¹	Comments
			Date	Inches					
E540-S17 A-C	E540-S17	6-1	06/27/13	0.508	0.508	2.2	N/A	N/A	Most locations were installed '12-'13
E540-S90 A-C	E540-S90	6-2	06/27/13	0.666	0.666	2.9	N/A	N/A	
E540-N55 A-C	E540-N55	6-3	06/27/13	0.604	0.604	2.6	N/A	N/A	
E540-N128 A-C	E540-N128	6-4	06/27/13	0.718	0.718	3.0	N/A	N/A	
E540-N200 A-C	E540-N200	6-5	06/27/13	0.734	0.734	3.1	N/A	N/A	
E540-N275 A-C	E540-N275	6-6	06/27/13	0.697	0.697	3.0	N/A	N/A	
E540-N350-2 A-C	E540-N350	6-7	06/27/13	0.695	0.695	3.0	N/A	N/A	Initial install was read only once.
E540-N425 A-C	E540-N425	6-8	06/27/13	0.736	0.736	3.1	N/A	N/A	
E540-N500-2 A-C	E540-N500	6-9	06/27/13	0.757	0.757	3.2	N/A	N/A	Initial install was read only once.
E540-N570 A-C	E540-N570	6-10	06/27/13	0.782	0.782	3.3	N/A	N/A	
E540-N640-2 A-C	E540-N640	6-11	06/27/13	0.821	2.036	3.5	4.6	-24%	
E540-N710 A-C	E540-N710	6-12	06/27/13	0.731	0.731	3.1	N/A	N/A	
E540-N860 A-C	E540-N860	6-13	06/11/13	0.914	0.914	3.0	N/A	N/A	
E690-S17-2 A-C	E690-S17	6-14	06/27/13	0.591	0.591	2.5	N/A	N/A	Initial install was read only once.
E690-S90 A-C	E690-S90	6-15	06/27/13	0.622	0.622	2.7	N/A	N/A	
E690-N55-2 A-C	E690-N55	6-16	06/27/13	0.612	0.612	2.6	N/A	N/A	Initial install was read only once.
E690-N128-2 A-C	E690-N128	6-17	06/27/13	0.677	1.456	2.9	N/A	N/A	
E690-N200-2 A-C	E690-N200	6-18	06/27/13	0.864	1.980	4.0	N/A	N/A	
E690-N275-2 A-C	E690-N275	6-19	06/27/13	0.76	1.632	3.5	N/A	N/A	
E690-N350-2 A-C	E690-N350	6-20	06/27/13	1.04	2.207	4.8	N/A	N/A	
E690-N425-2 A-C	E690-N425	6-21	06/27/13	0.793	1.616	3.7	N/A	N/A	
E690-N500-2 A-C	E690-N500	6-22	06/27/13	1.064	2.054	4.9	N/A	N/A	
E690-N640 A-C	E690-N640	6-23	12/18/12	1.936	1.936	3.6	N/A	N/A	
E690-N860 A-C	E690-N860	6-24	12/11/12	0.222	0.222	2.3	N/A	N/A	
N780-E220-4 A-C	N780-E220	6-25	06/27/13	0.648	14.074	3.4	2.3	48%	
N780-E300-3 A-C	N780-E300	6-26	06/27/13	0.975	3.604	2.8	3	-7%	
N780-E420-2 A-C	N780-E420	6-27	06/27/13	1.044	4.870	3.0	6.4	-53%	
N780-E540-2 A-C	N780-E540	6-28	06/27/13	1.399	5.819	4.1	15.4	-73%	

Table 6-1, Continued
SDI Data Analysis

Convergence Points, Continued									
Field Tag	Location	Figure Number	Last Reading 2012 to 2013		Cumulative Displacement (inches)	Closure Rate 2012 to 2013 (in/year)	Closure Rate ¹ 2011 to 2012 (in/year)	Rate Change Percent ¹	Comments
			Date	Inches					
N780-E615-2 A-C	N780-E615	6-29	06/27/13	0.712	3.93	3.3	5.5	-40%	
N780-E690-2 A-C	N780-E690	6-30	06/27/13	1.145	6.495	5.2	9	-42%	
N780-E768 A-C	N780-E768	6-31	06/27/13	1.303	1.303	5.9	N/A	N/A	
N780-E845 A-C	N780-E845	6-32	06/27/13	1.528	1.528	7.0	N/A	N/A	
N780-E922 A-C	N780-E922	6-33	06/27/13	1.659	1.659	7.6	N/A	N/A	
N780-E1000 A-C	N780-E1000	6-34	06/27/13	1.864	1.864	11.5	N/A	N/A	
N780-E1050 A-C	N780-E1050	6-35	06/27/13	1.508	1.508	9.3	N/A	N/A	
N780-E1100 A-C	N780-E1100	6-36	06/27/13	1.714	1.714	10.6	N/A	N/A	
N780-E1150 A-C	N780-E1150	6-37	06/27/13	1.229	1.229	7.6	N/A	N/A	
N780-E1200 A-C	N780-E1200	6-38	05/13/13	0.268	0.268	7.0	N/A	N/A	
N780-E1250 A-C	N780-E1250	6-39	05/13/13	0.254	0.254	6.6	N/A	N/A	
N940-E220-2 A-C	N940-E220	6-40	06/11/13	0.444	1.879	1.5	3.2	-53%	
N940-E300-2 A-C	N940-E300	6-41	06/11/13	0.543	2.309	1.8	3.9	-54%	
N940-E420-2 A-C	N940-E420	6-42	06/11/13	0.791	3.237	2.6	5.9	-56%	
N940-E540-2 A-C	N940-E540	6-43	06/11/13	0.86	3.811	2.9	7	-59%	
N940-E615-2 A-C	N940-E615	6-44	06/11/13	0.988	3.813	3.3	7.8	-58%	
N940-E690-3 A-C	N940-E690	6-45	06/11/13	1.815	4.183	6.0	5.5	9%	
S90-E615 A-C	S90-E615	6-46	06/27/13	0.58	0.58	2.5	N/A	N/A	

N/A – Insufficient data available to perform the calculation. This is usually due to the inability to read the instruments because of activities such as: the temporary removal of an instrument due to floor, rib or back trimming; locations blocked by equipment or waste disposal, installation timing, etc.

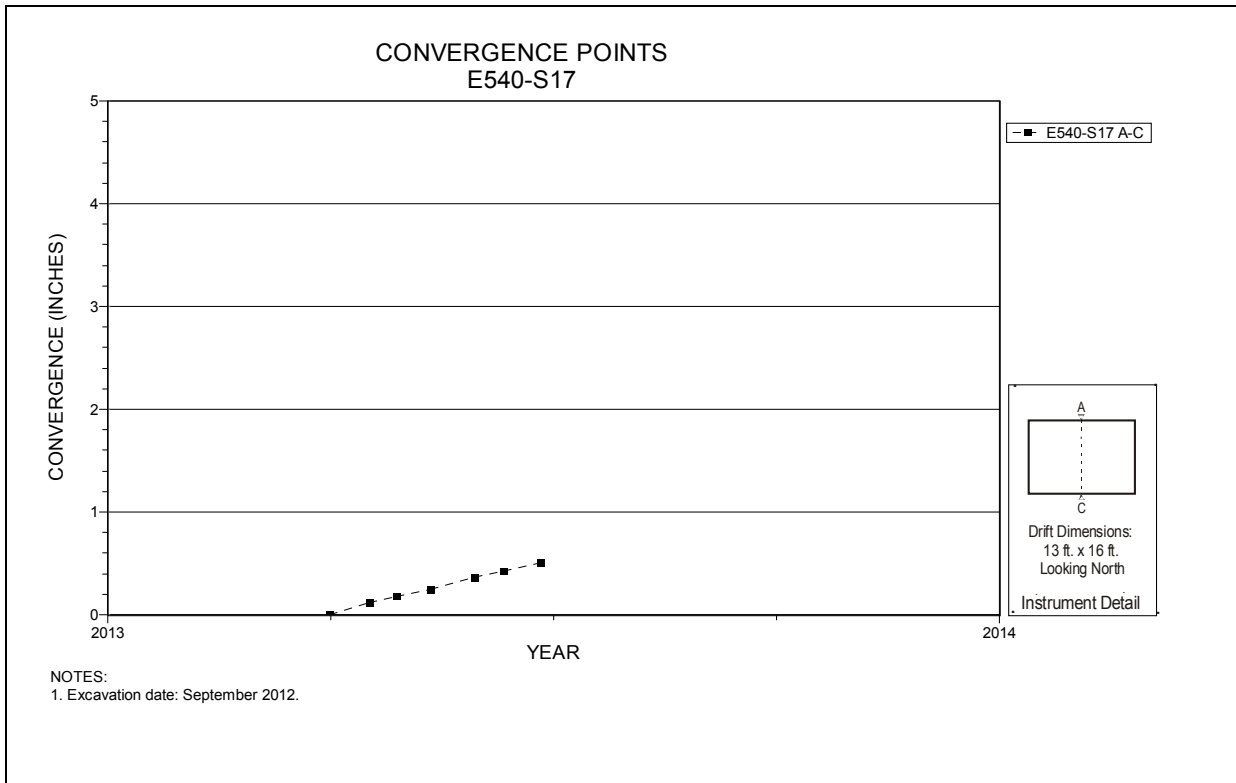

Figure 6-1 Convergence Point Array
E540 S17 – Roof to Floor

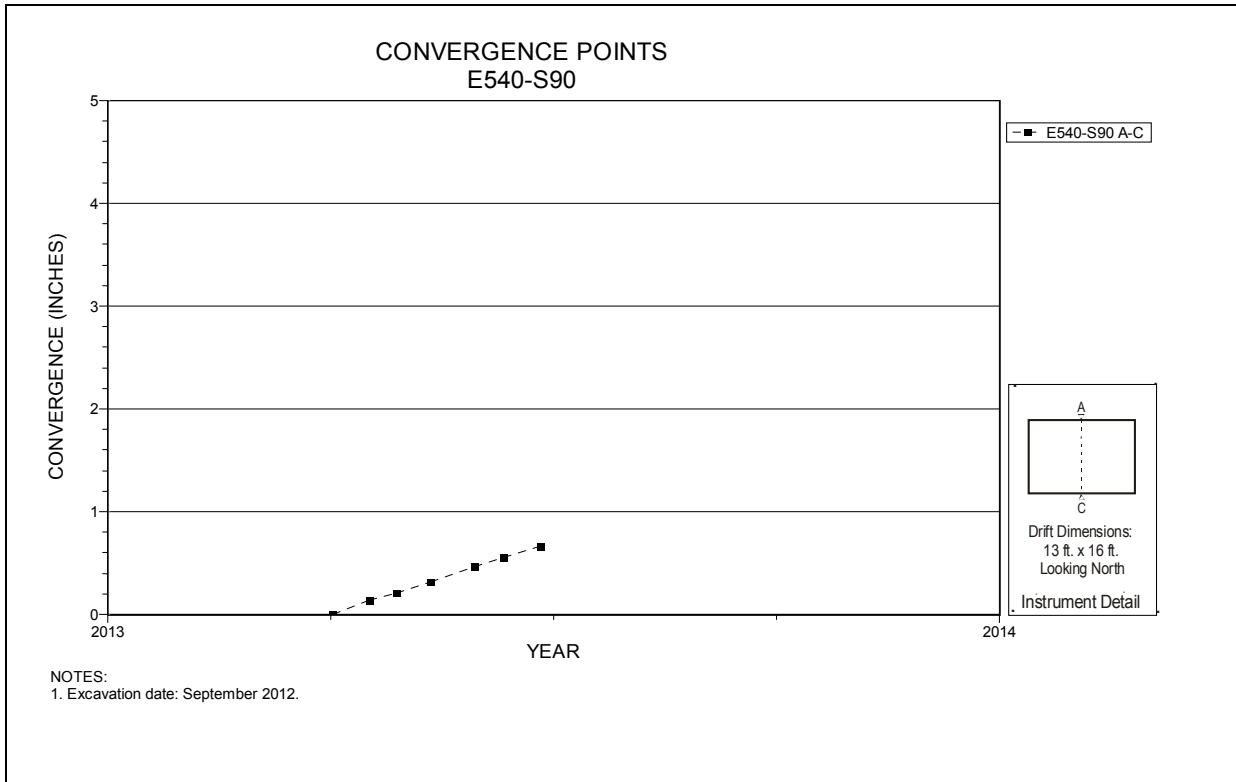
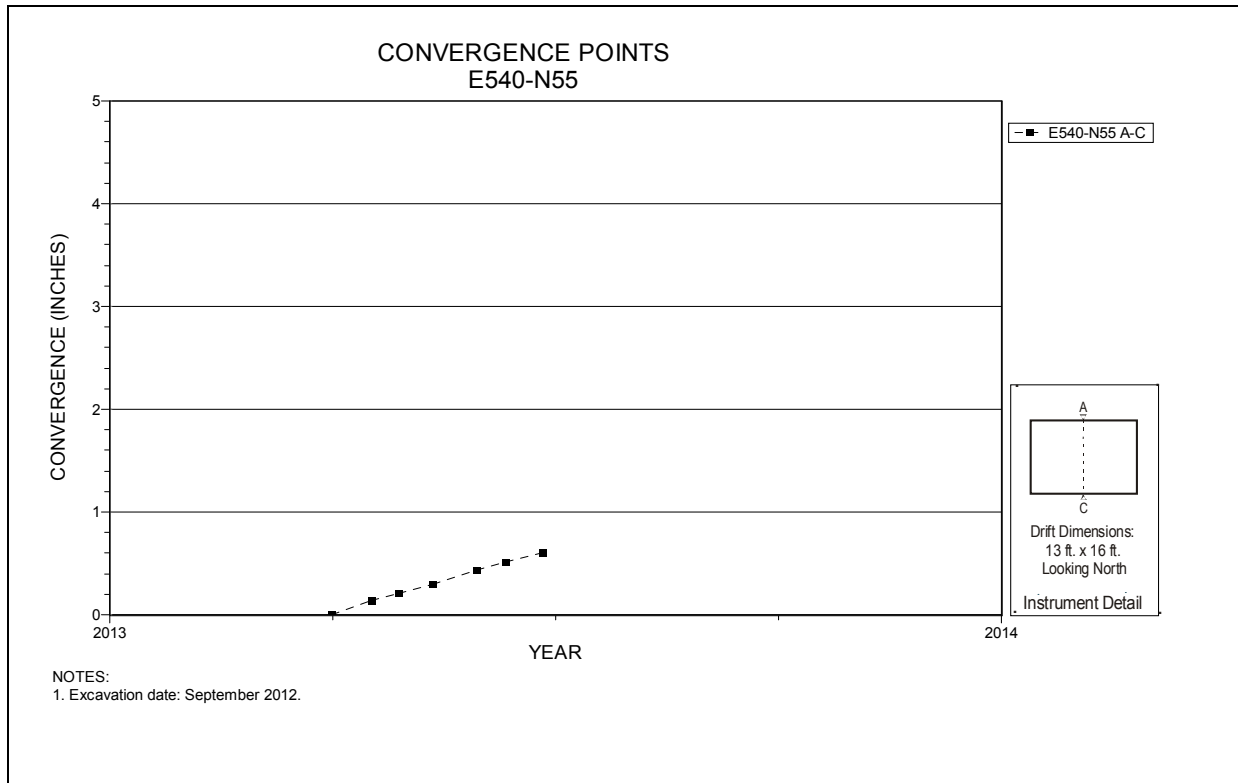
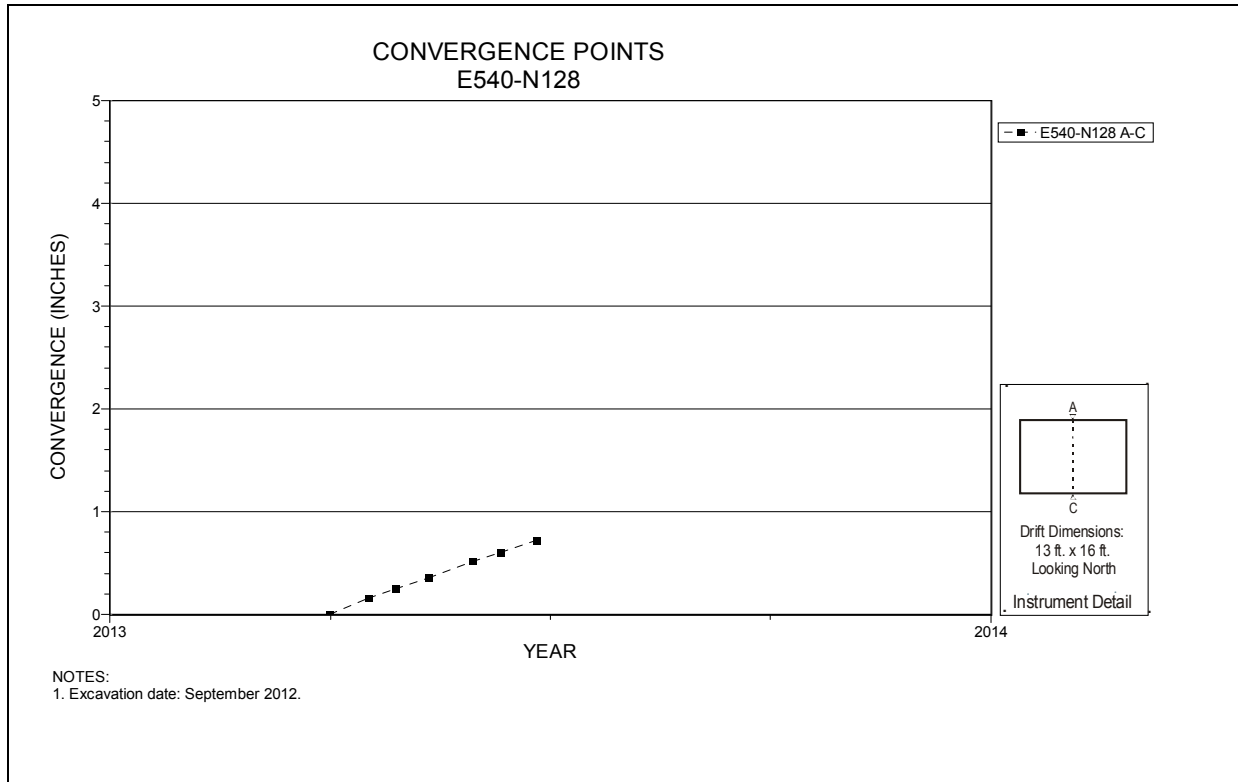

Figure 6-2 Convergence Point Array
E540 S90 – Roof to Floor



**Figure 6-3 Convergence Point Array
E540 N55 – Roof to Floor**



**Figure 6-4 Convergence Point Array
E540 N128 – Roof to Floor**

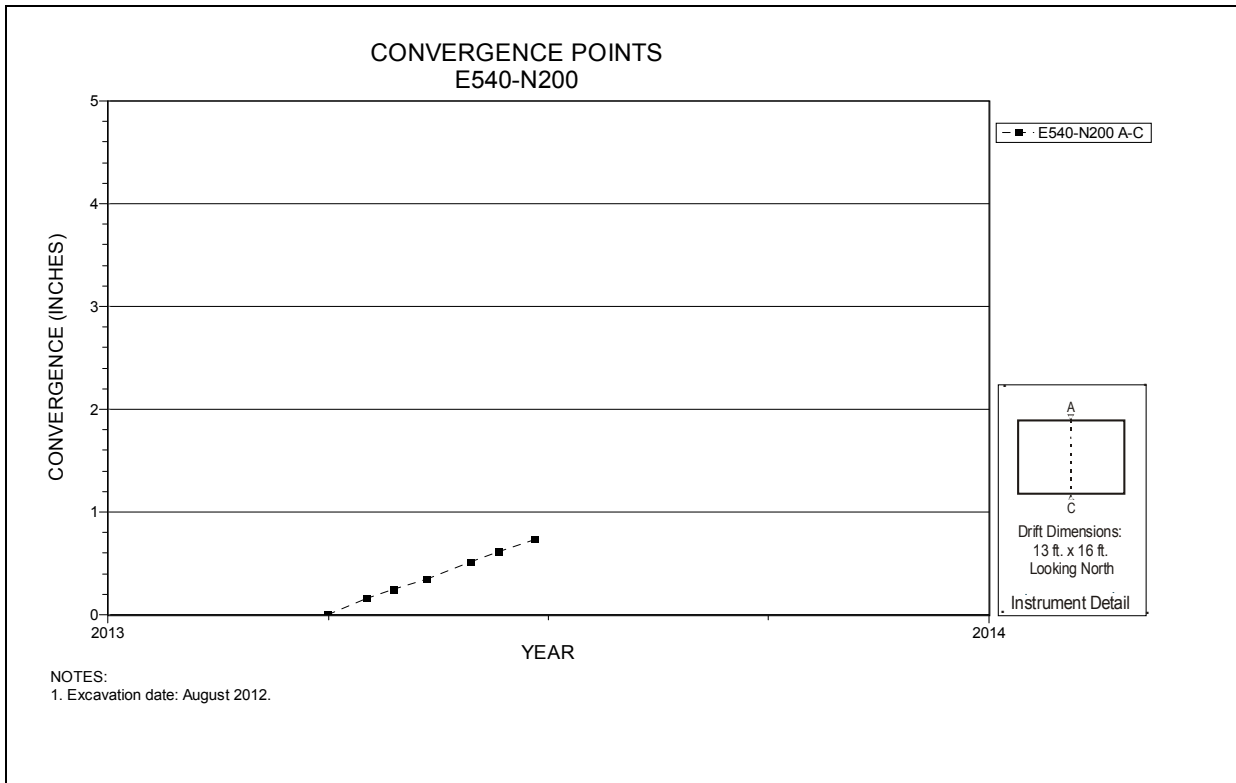

**Figure 6-5 Convergence Point Array
E540 N200 – Roof to Floor**

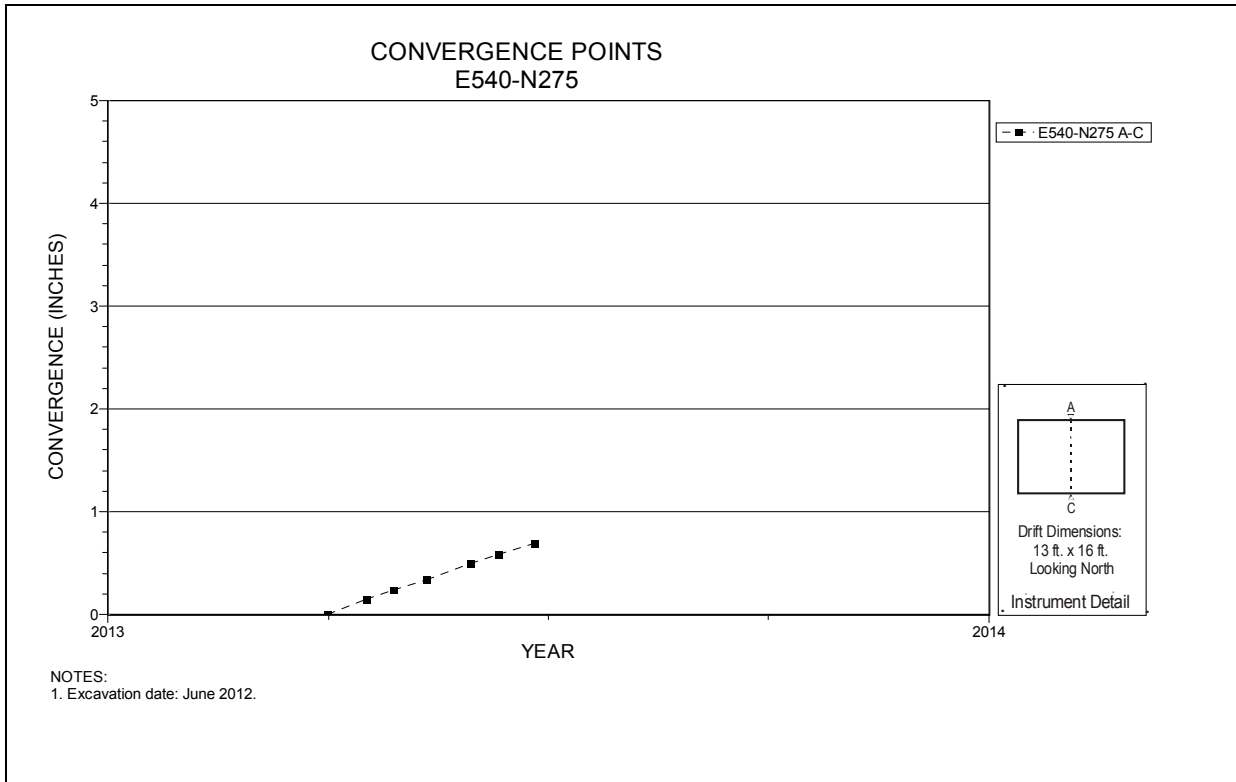

**Figure 6-6 Convergence Point Array
E540 N275 – Roof to Floor**

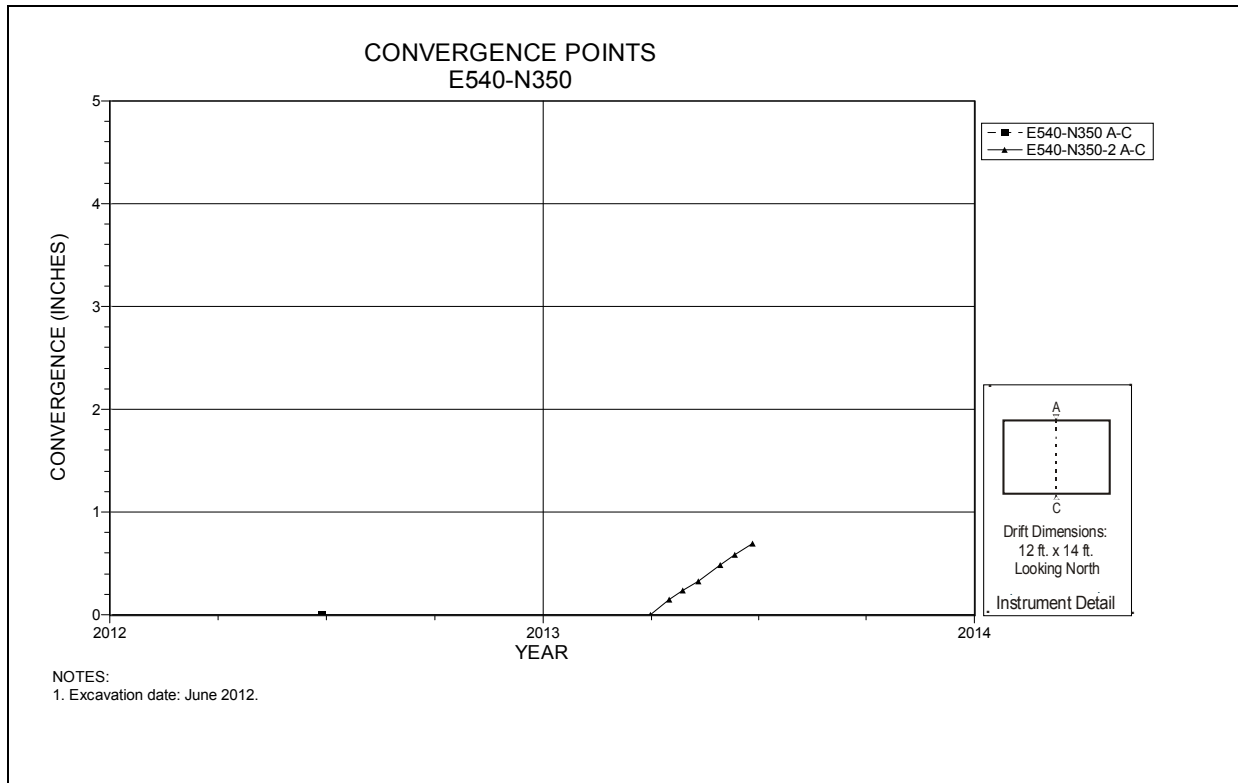

Figure 6-7 Convergence Point Array
E540 N350 – Roof to Floor

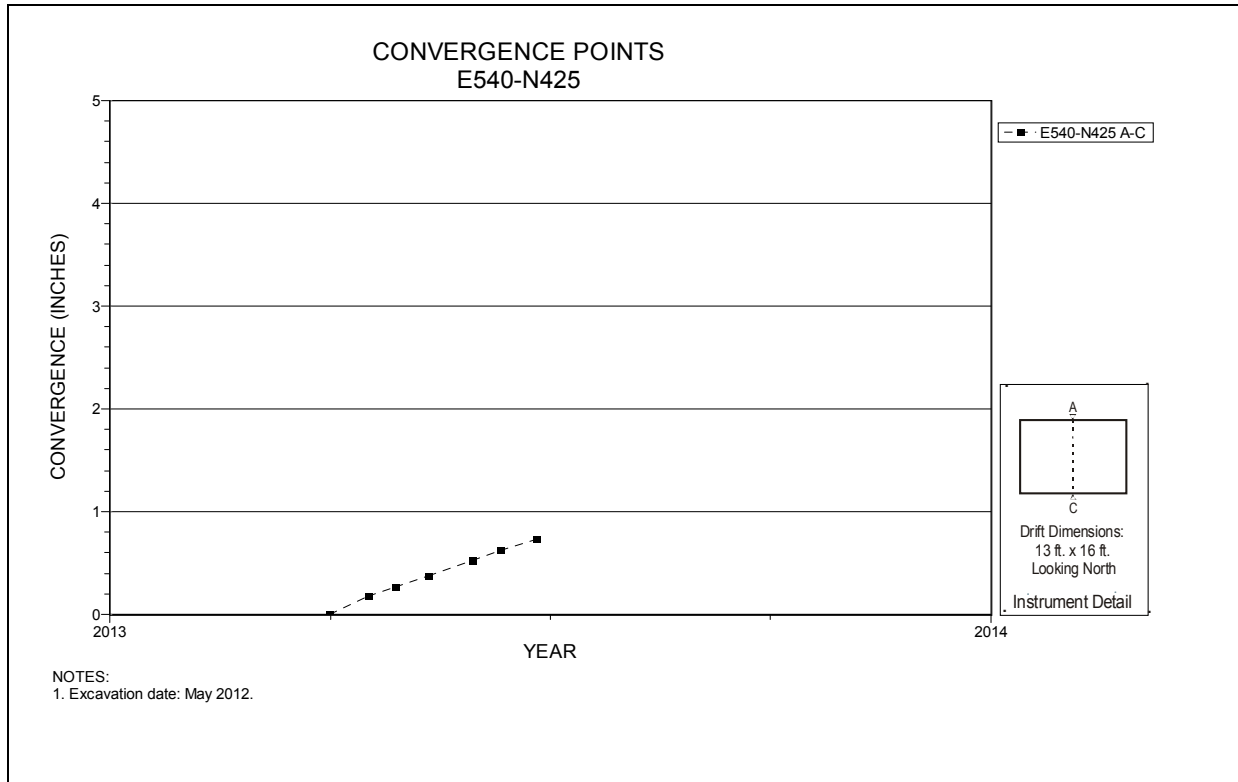

Figure 6-8 Convergence Point Array
E540 N425 – Roof to Floor

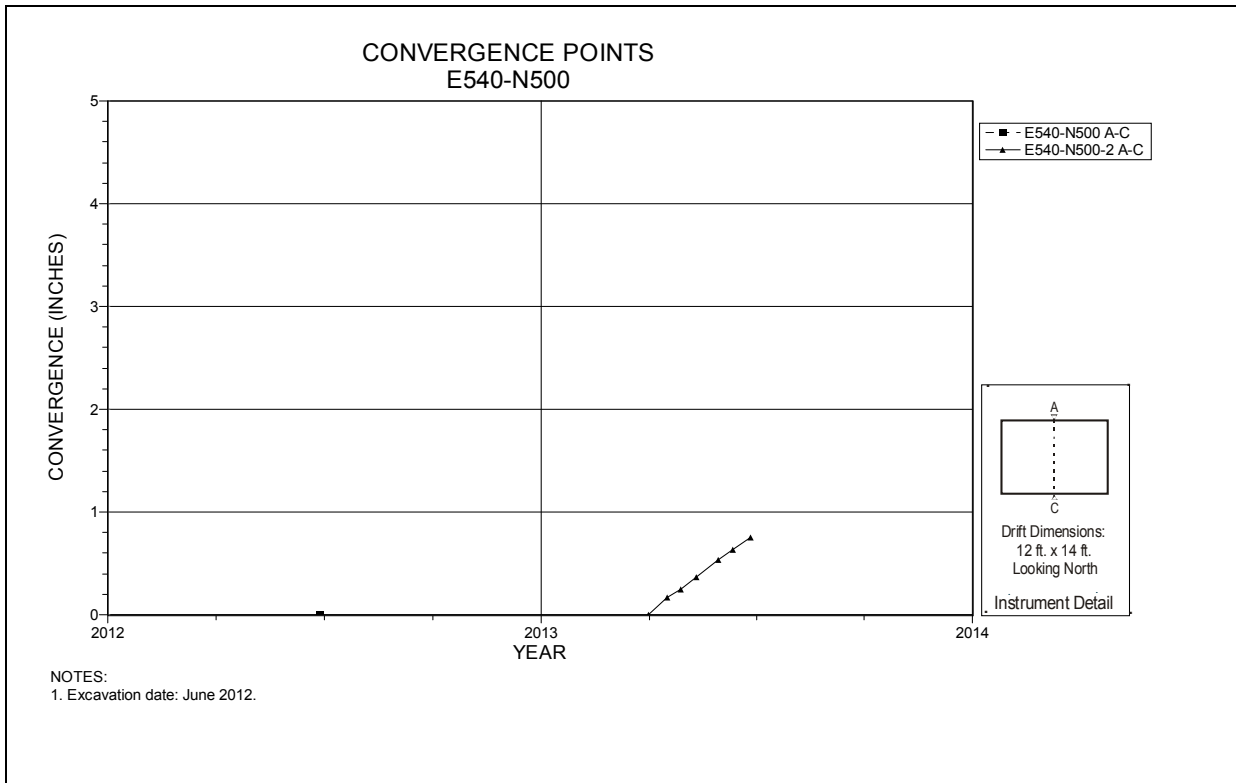

Figure 6-9 Convergence Point Array
E540 N500 – Roof to Floor

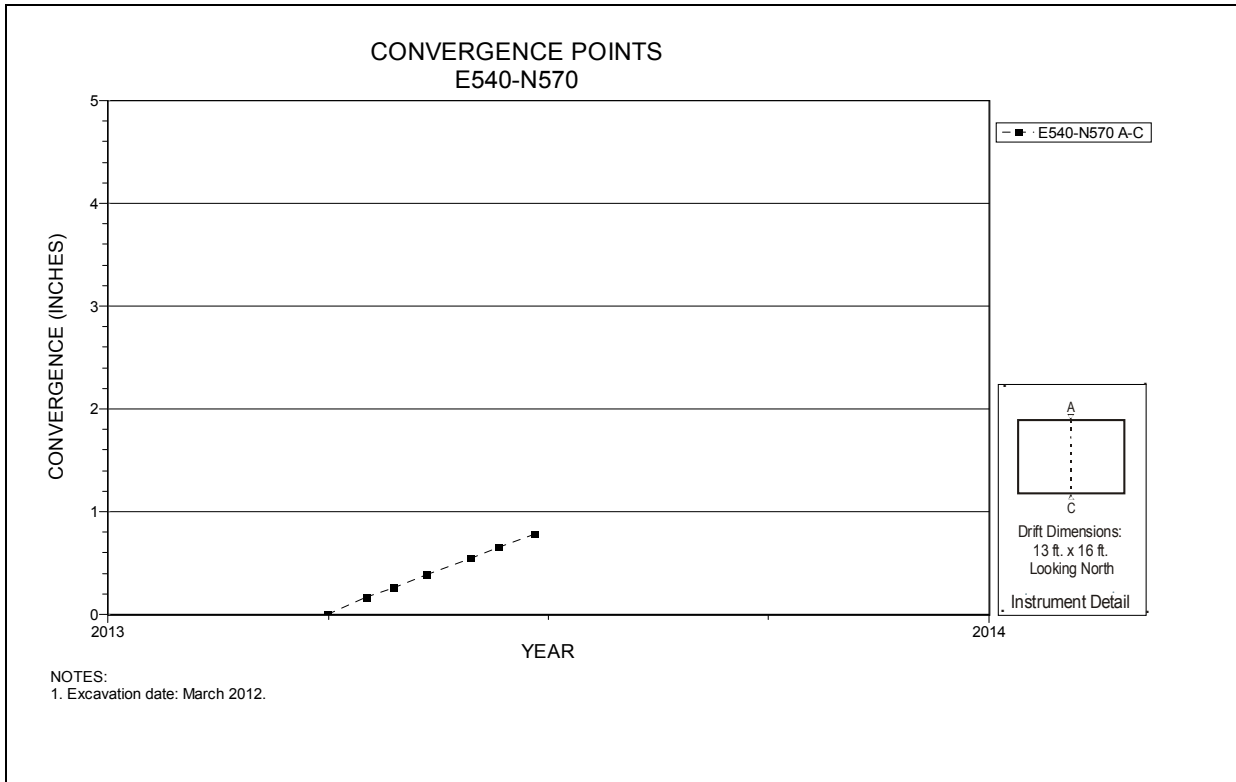
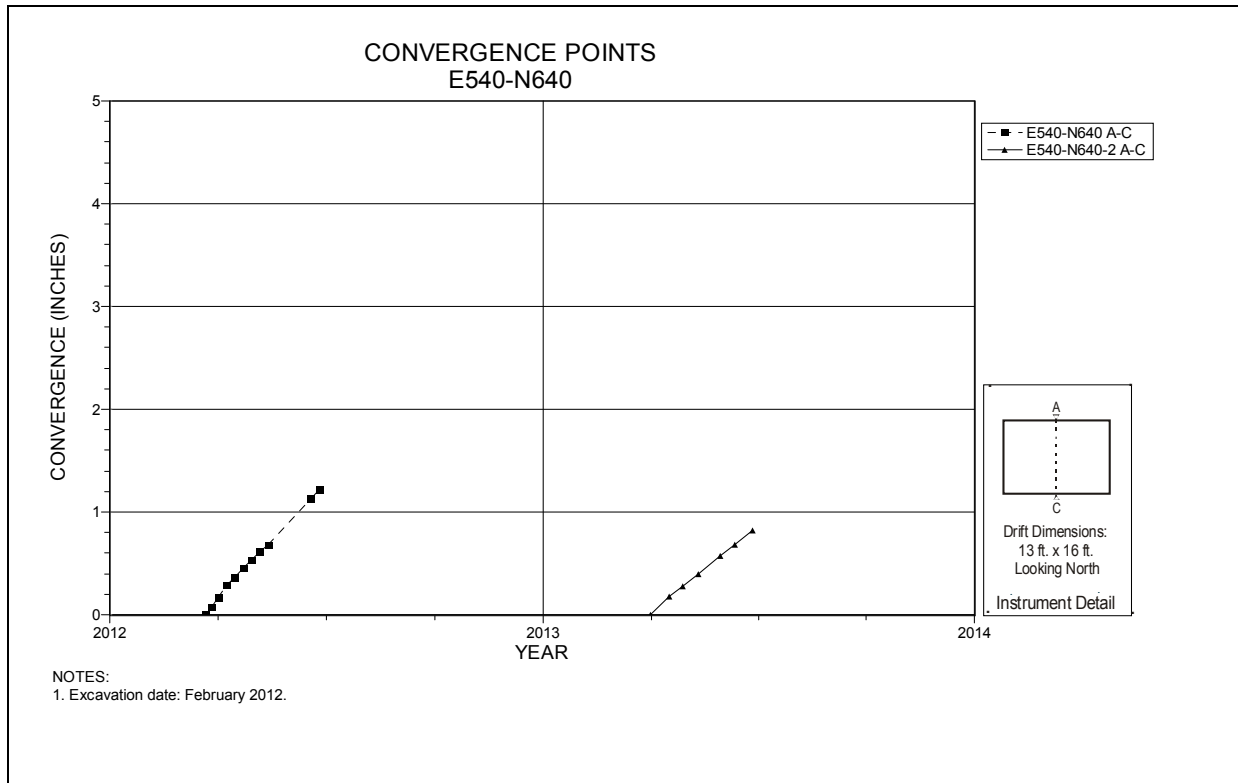
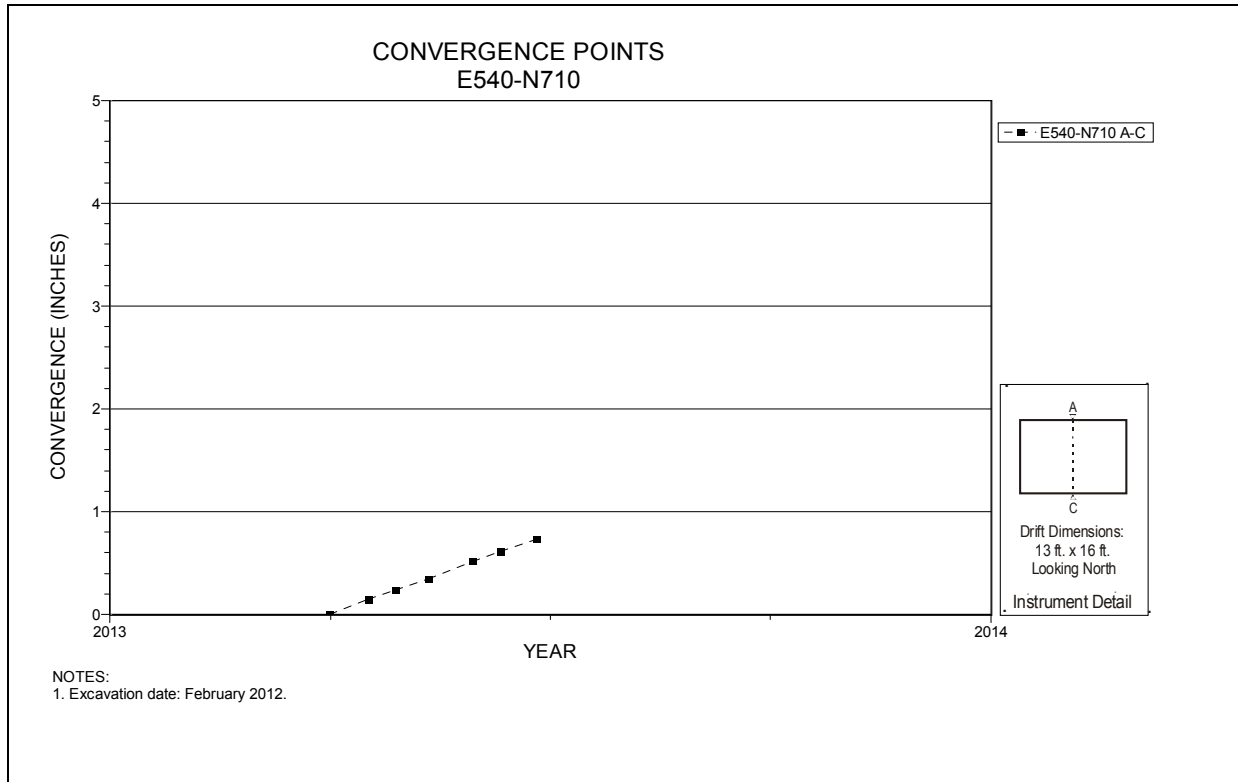

Figure 6-10 Convergence Point Array
E540 N570 – Roof to Floor



**Figure 6-11 Convergence Point Array
E540 N640 – Roof to Floor**



**Figure 6-12 Convergence Point Array
E540 N710 – Roof to Floor**

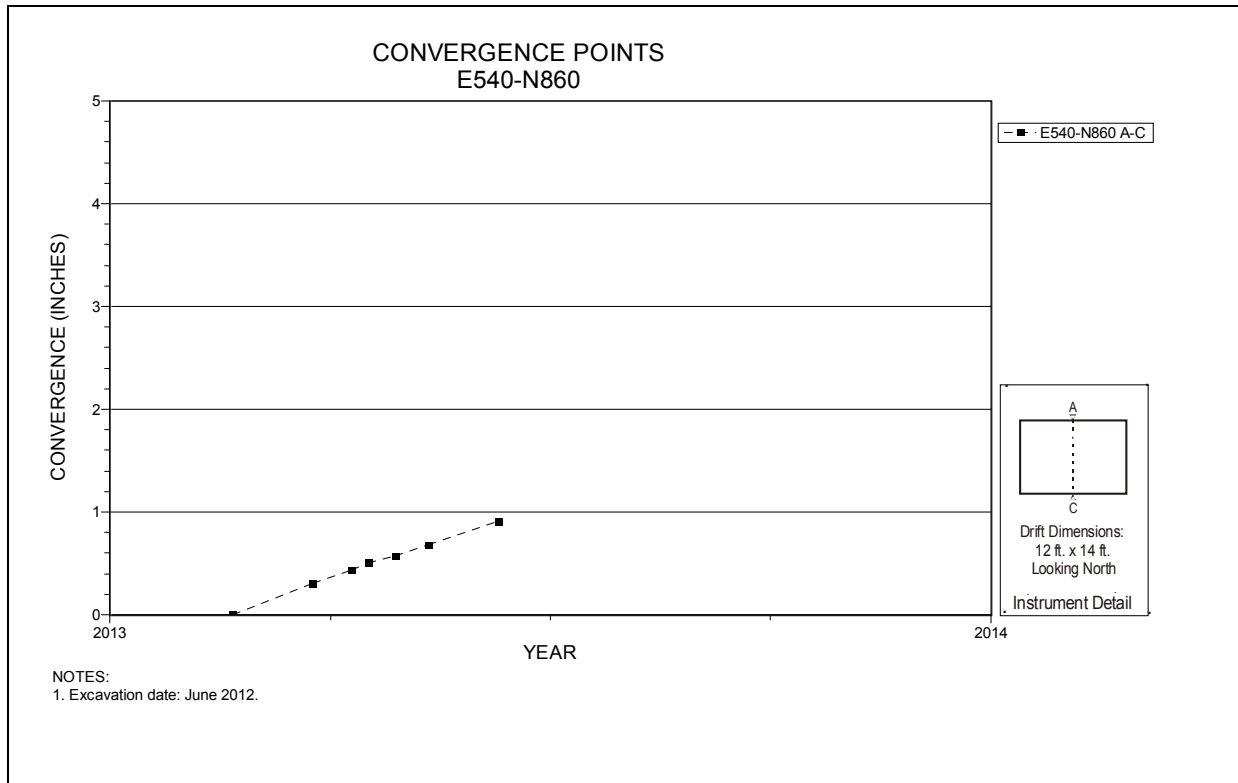

Figure 6-13 Convergence Point Array
E540 N860 – Roof to Floor

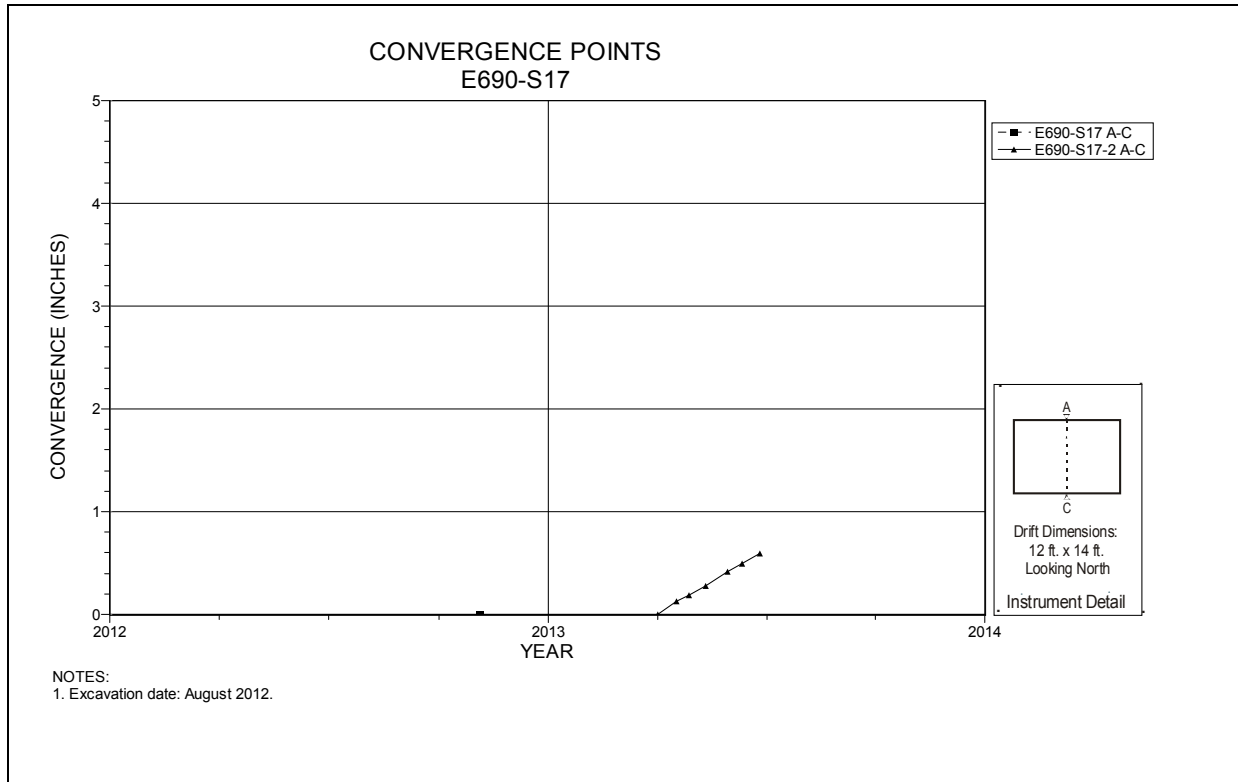
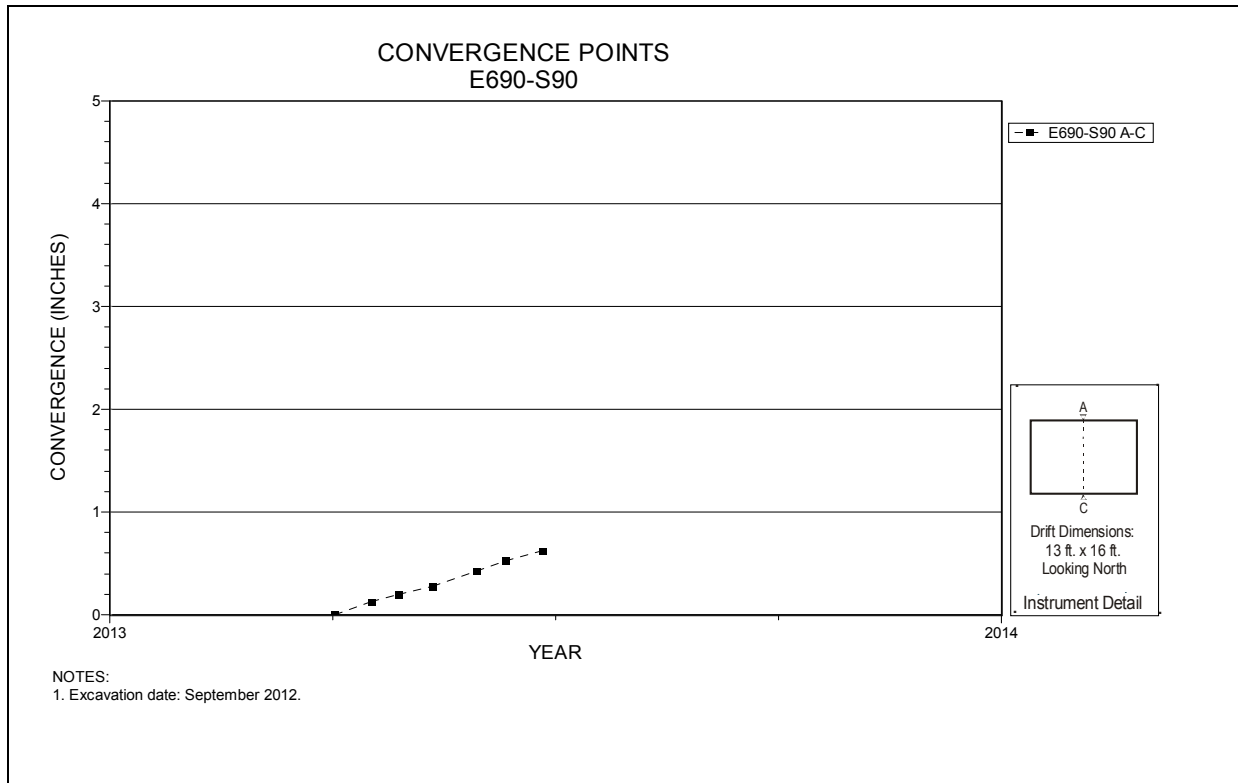
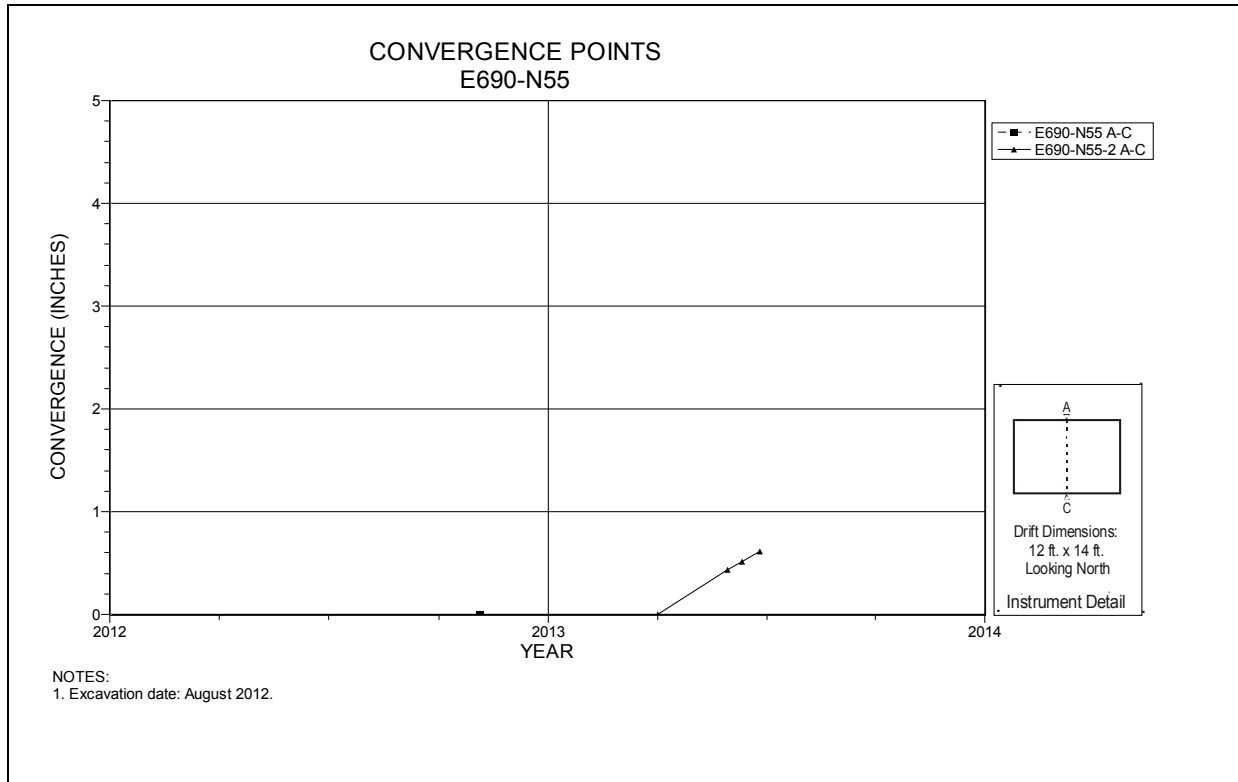

Figure 6-14 Convergence Point Array
E690 S17 – Roof to Floor



**Figure 6-15 Convergence Point Array
E690 S90 – Roof to Floor**



**Figure 6-16 Convergence Point Array
E690 N55 – Roof to Floor**

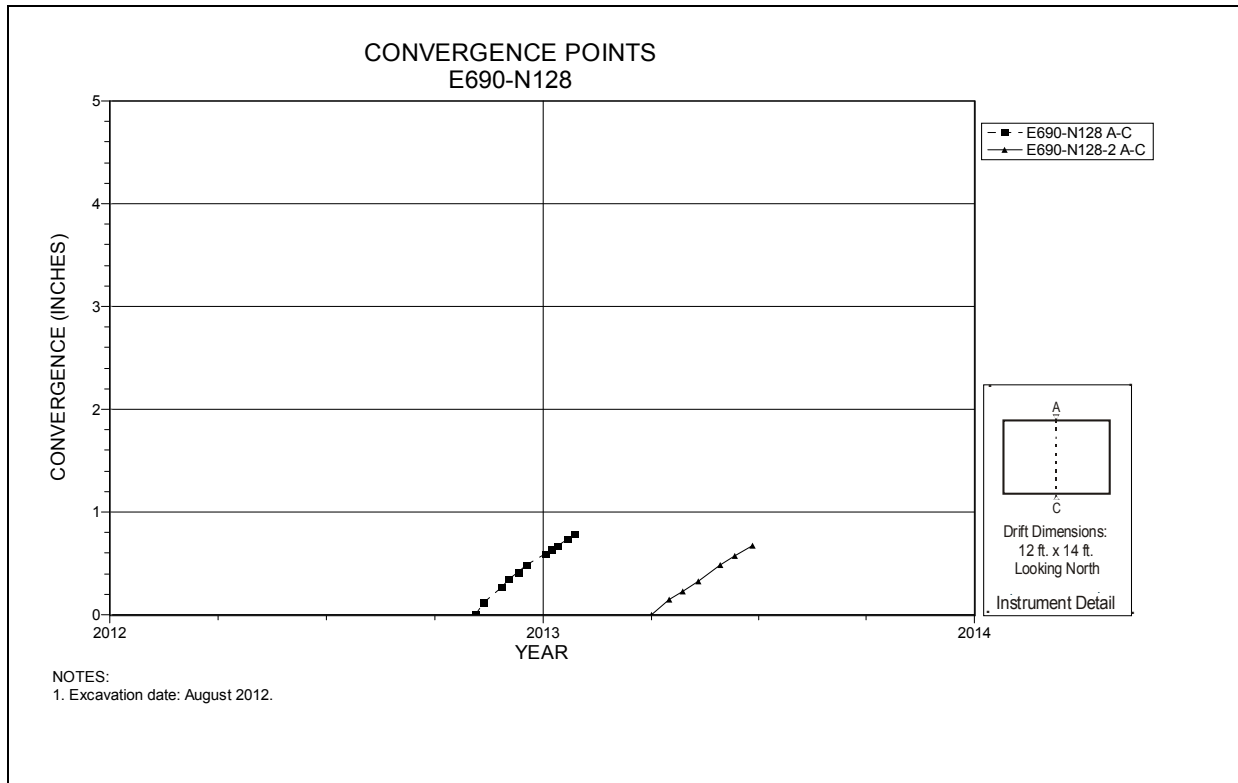

**Figure 6-17 Convergence Point Array
E690 N128 – Roof to Floor**

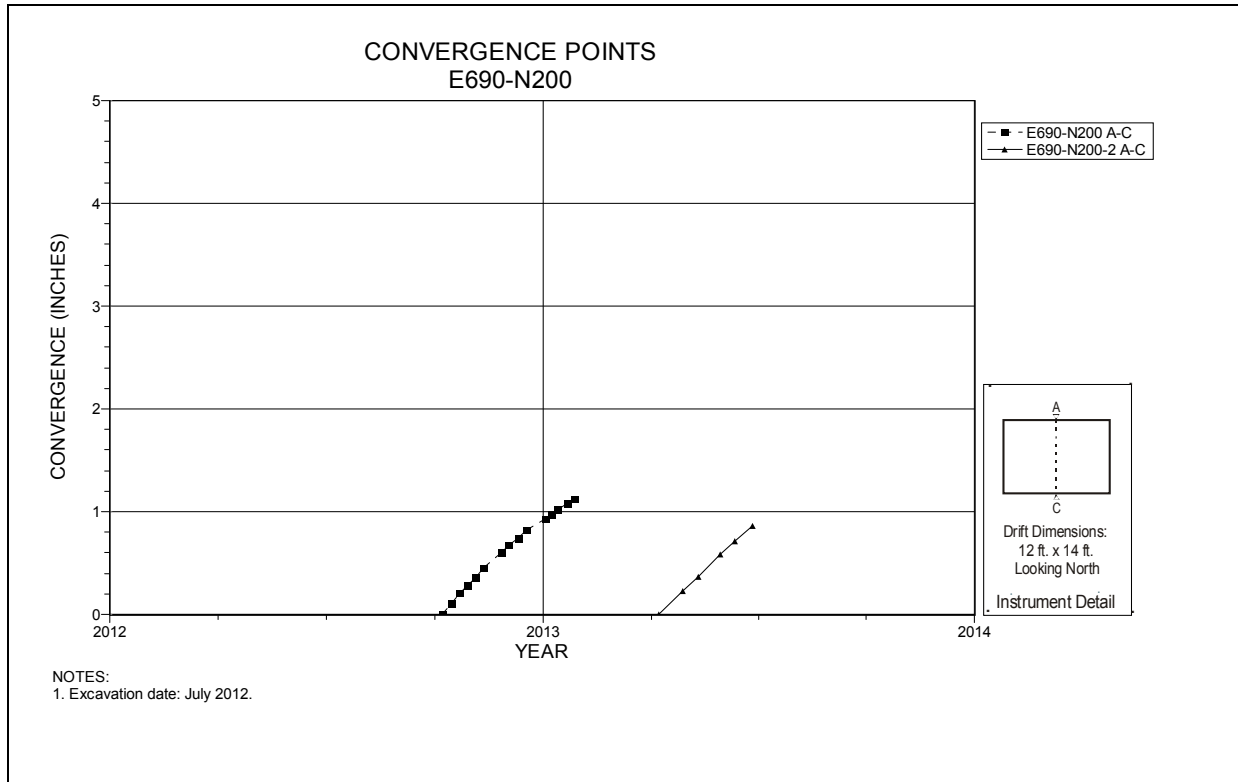

**Figure 6-18 Convergence Point Array
E690 N200 – Roof to Floor**

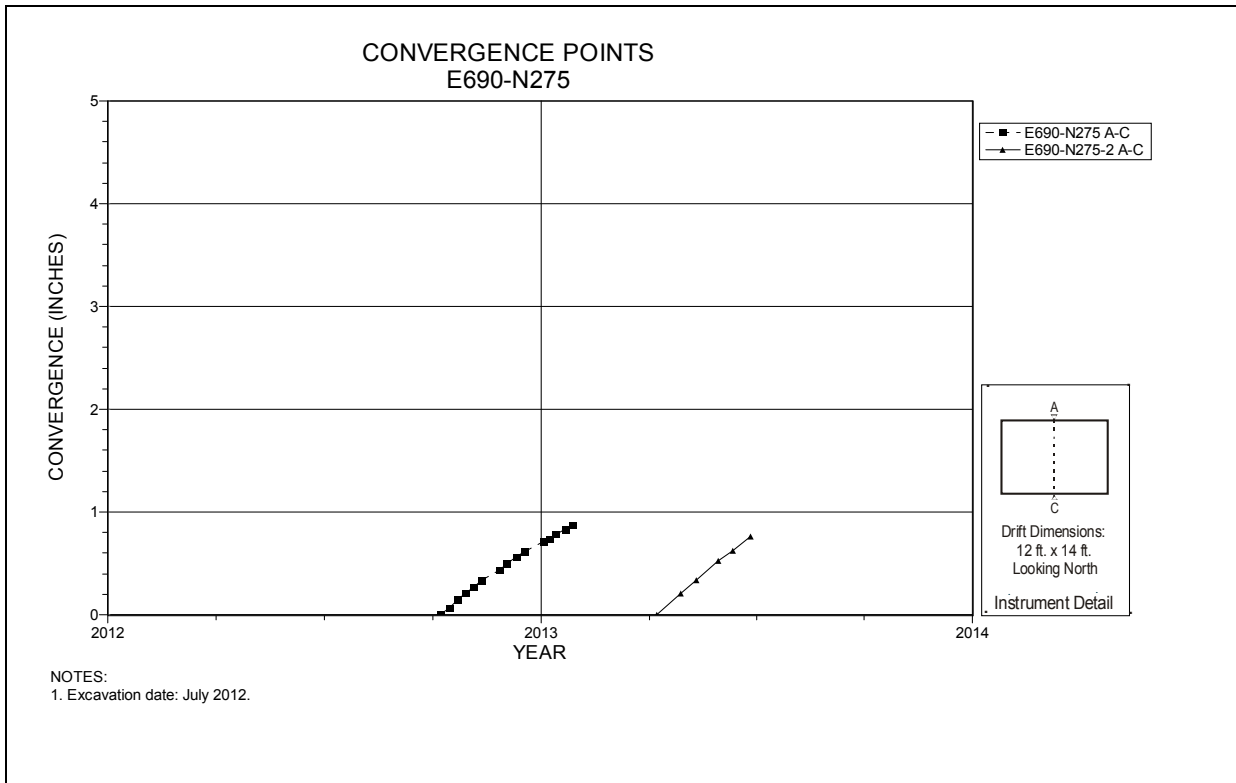

Figure 6-19 Convergence Point Array
E690 N275 – Roof to Floor

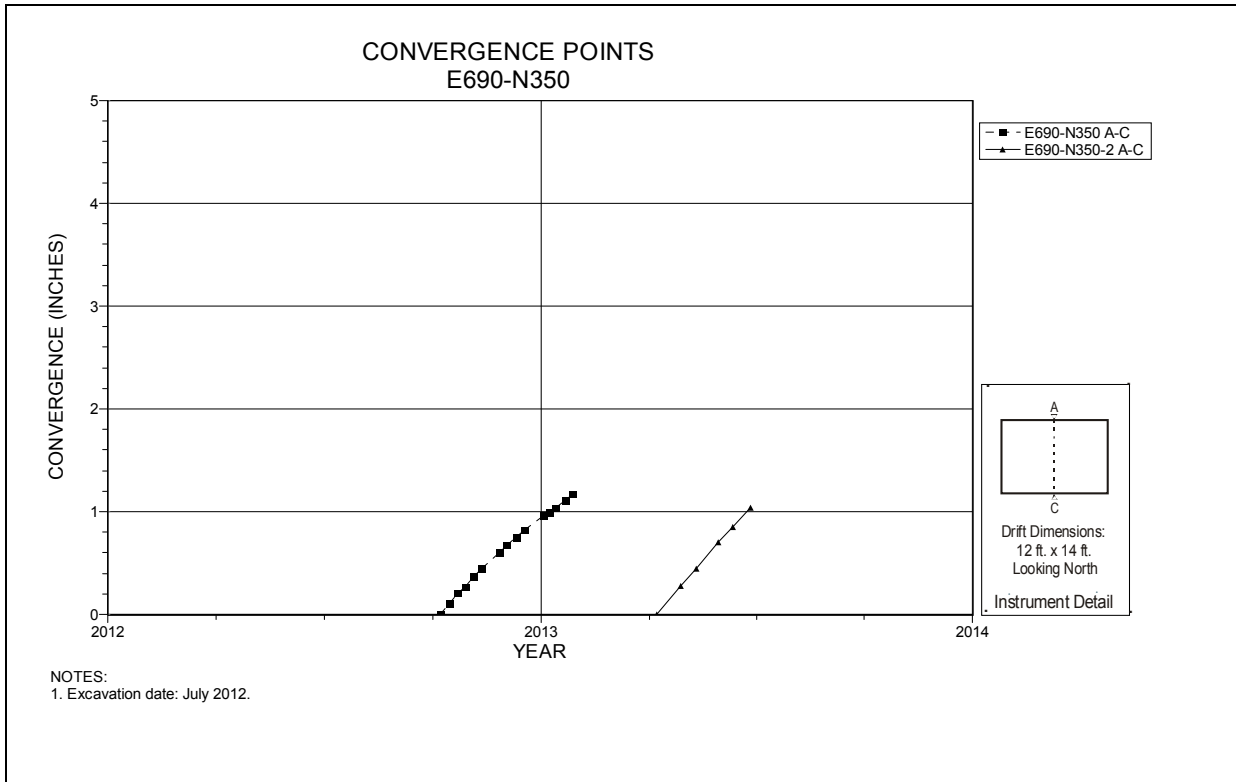

Figure 6-20 Convergence Point Array
E690 N350 – Roof to Floor

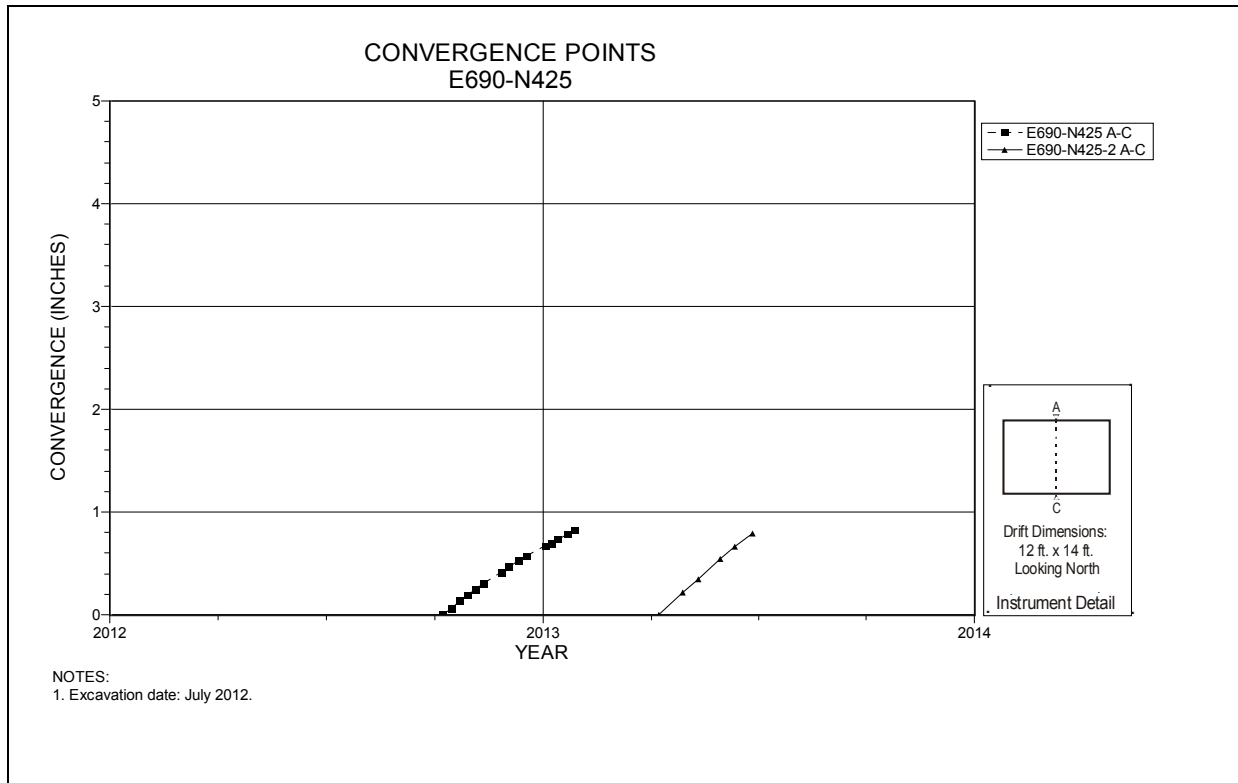

Figure 6-21 Convergence Point Array
E690 N425 – Roof to Floor

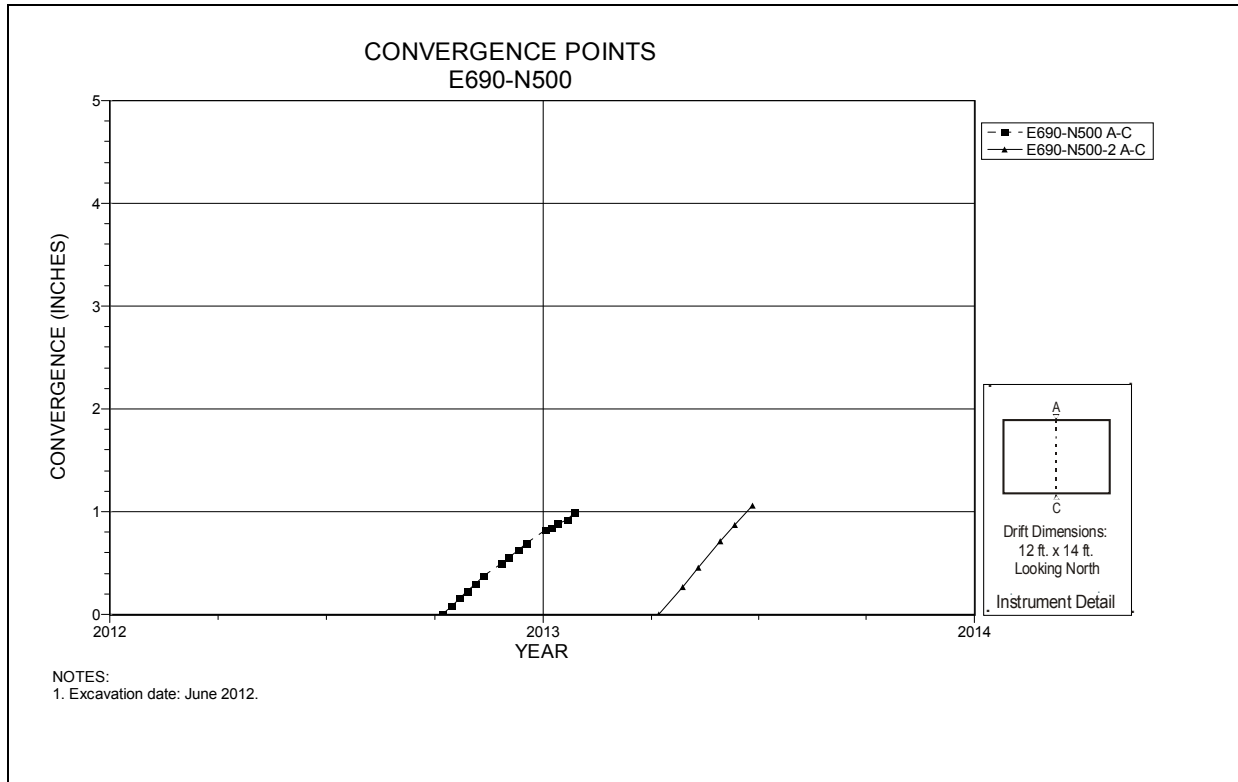
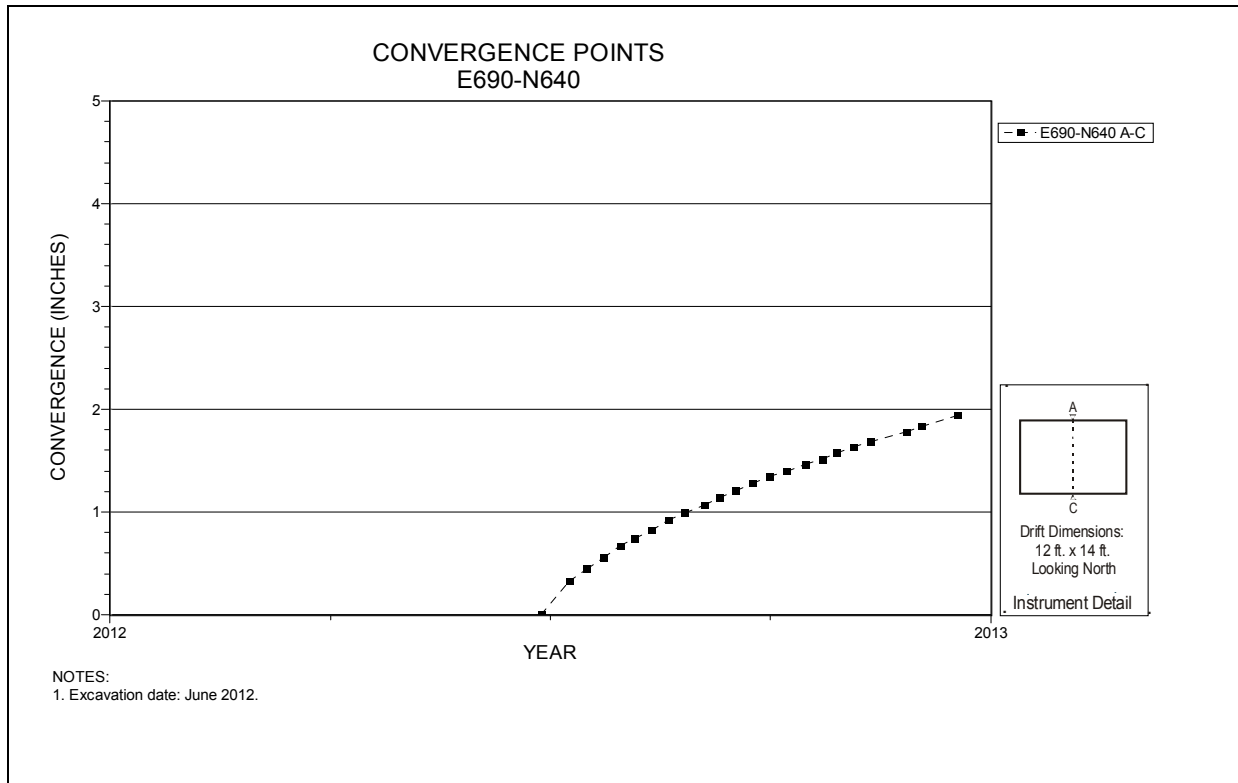
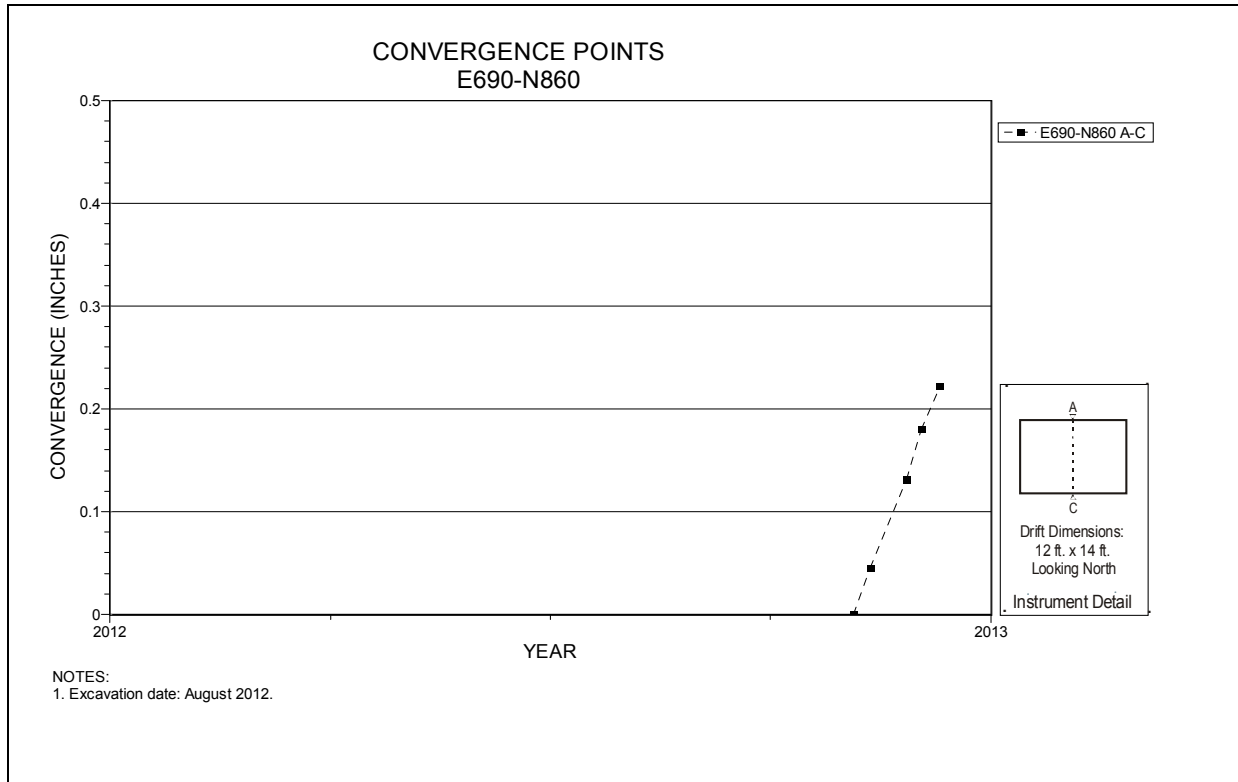

Figure 6-22 Convergence Point Array
E690 N500 – Roof to Floor



**Figure 6-23 Convergence Point Array
E690 N640 – Roof to Floor**



**Figure 6-24 Convergence Point Array
E690 N860 – Roof to Floor**

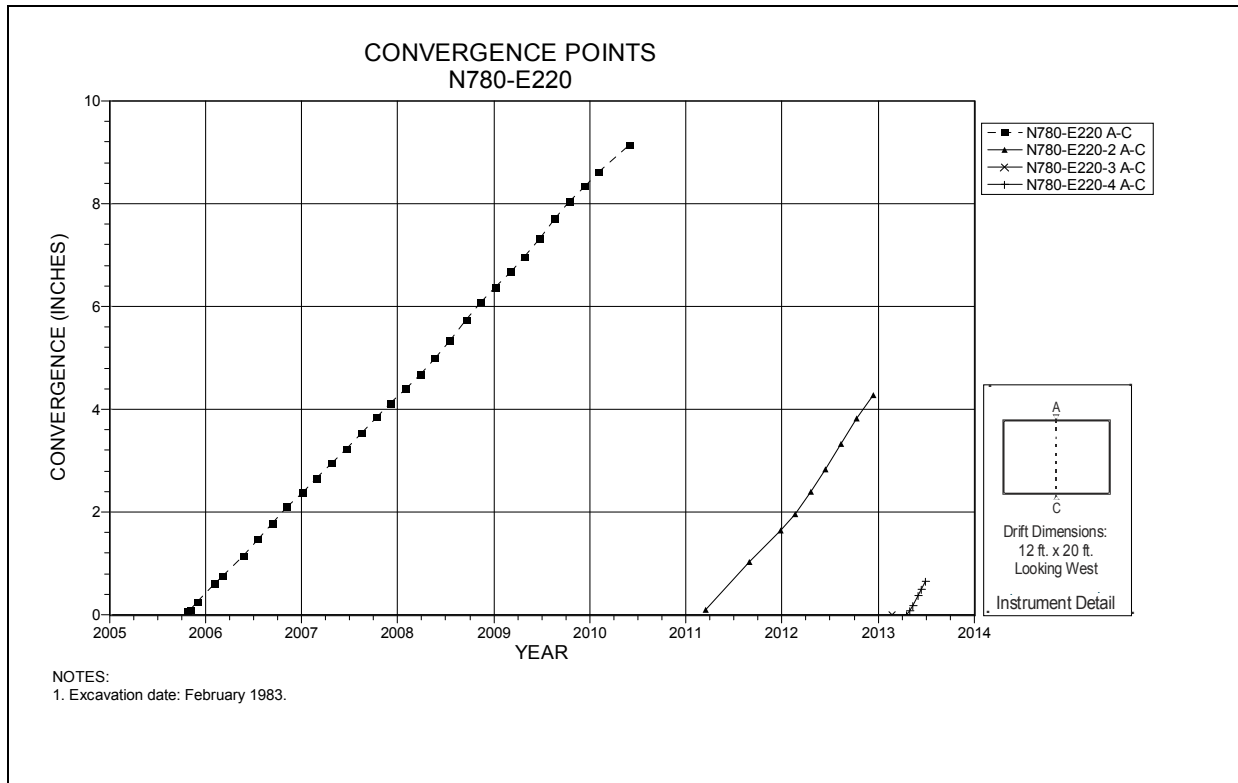

Figure 6-25 Convergence Point Array
N780 E220 – Roof to Floor

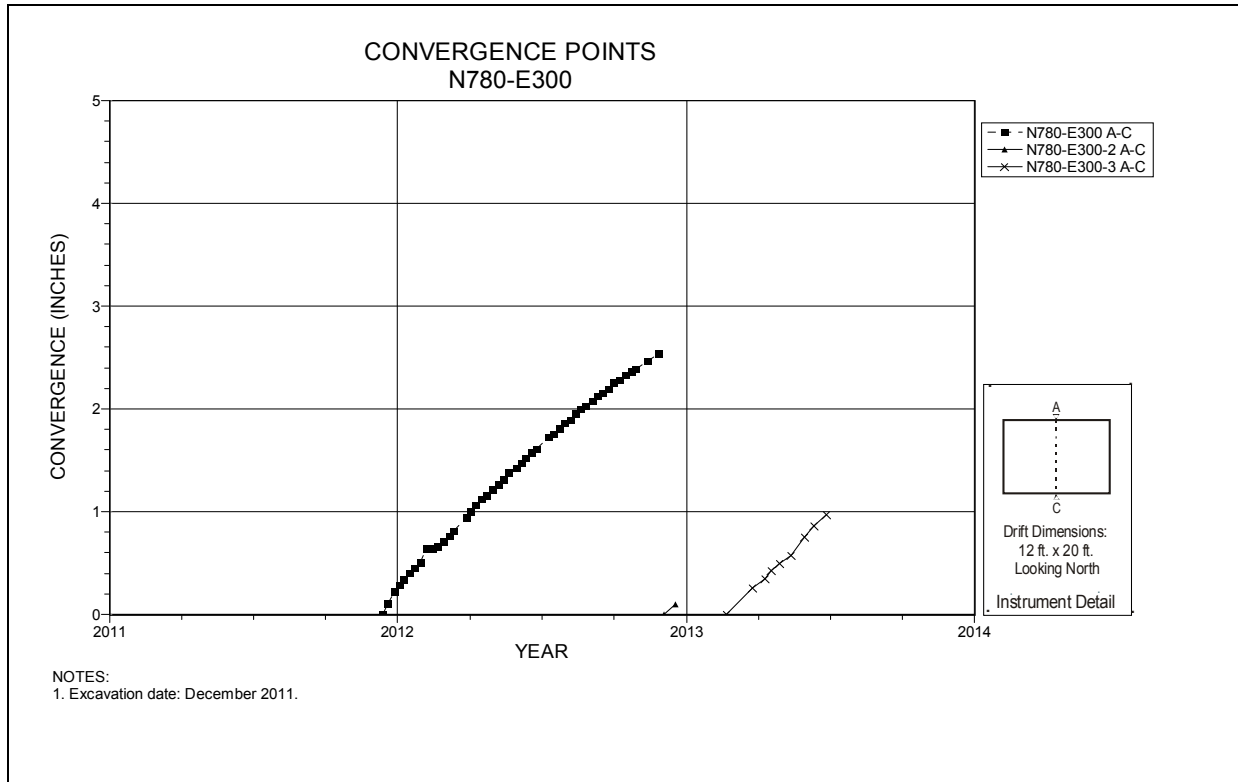

Figure 6-26 Convergence Point Array
N780 E300 – Roof to Floor

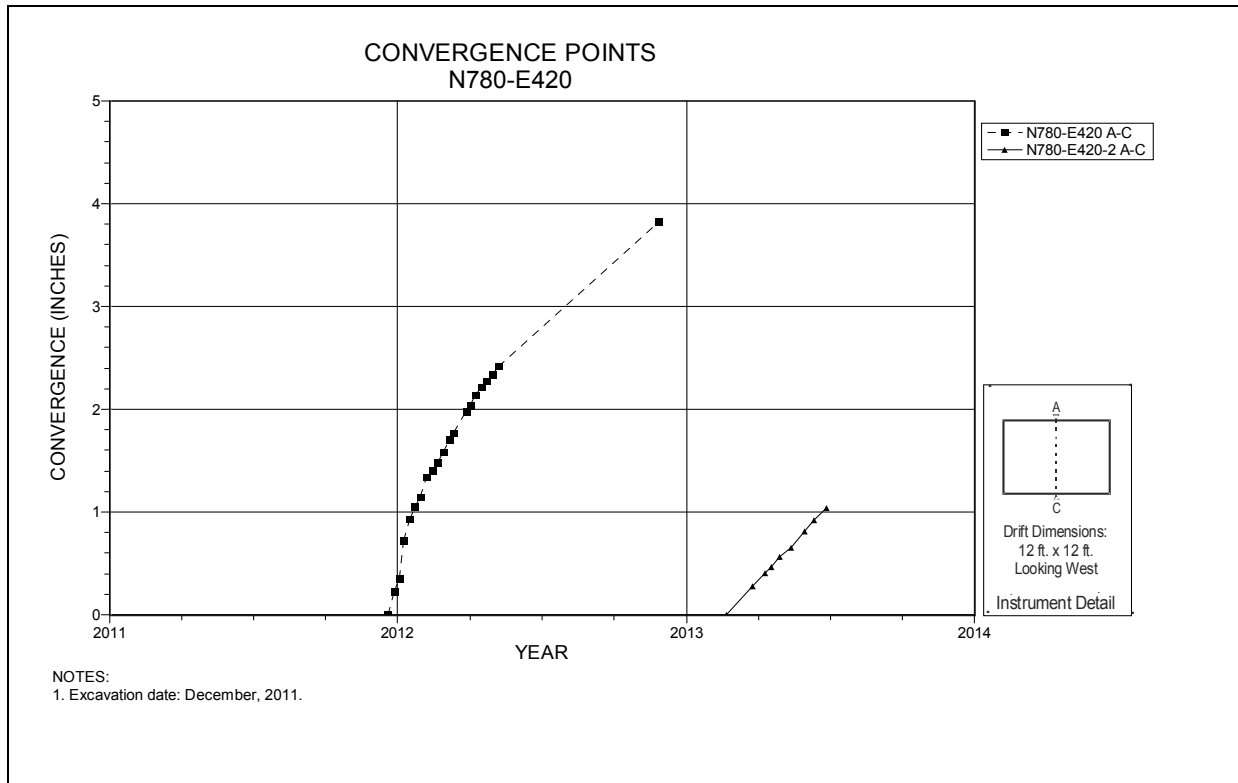

Figure 6-27 Convergence Point Array
N780 E420 – Roof to Floor

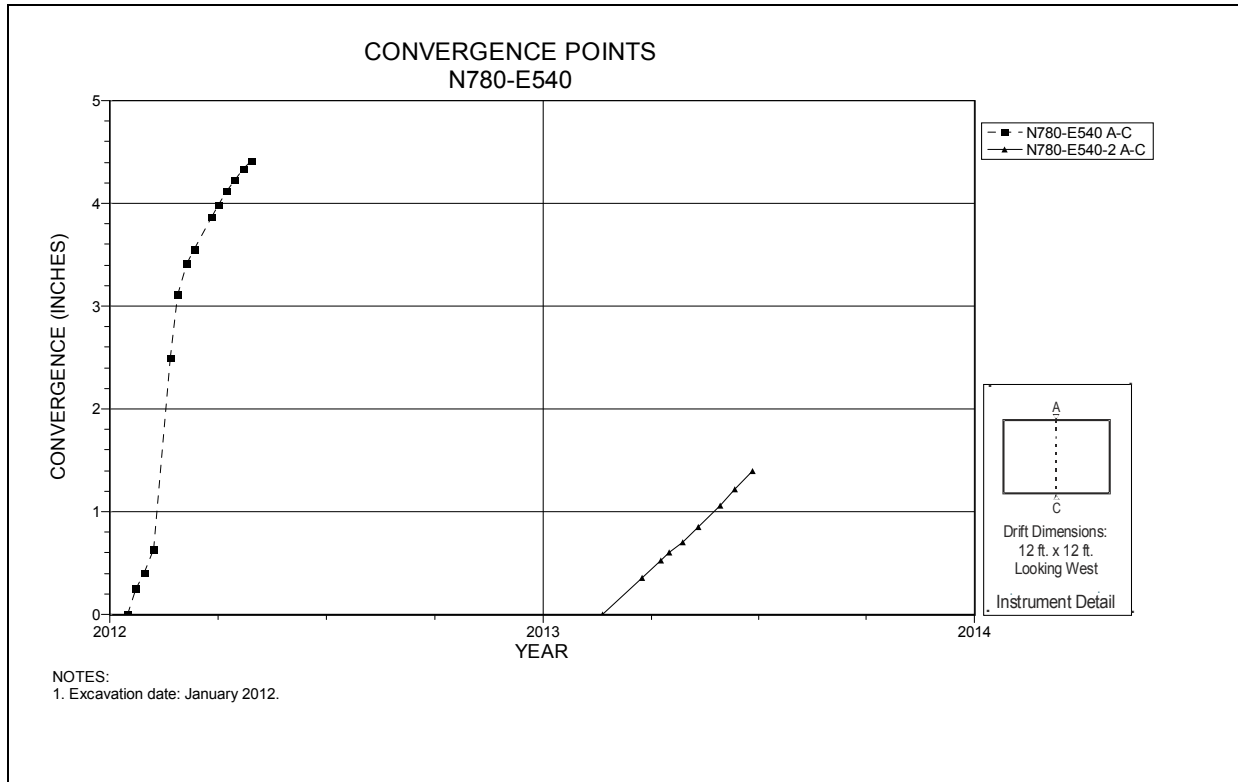

Figure 6-28 Convergence Point Array
N780 E540 – Roof to Floor

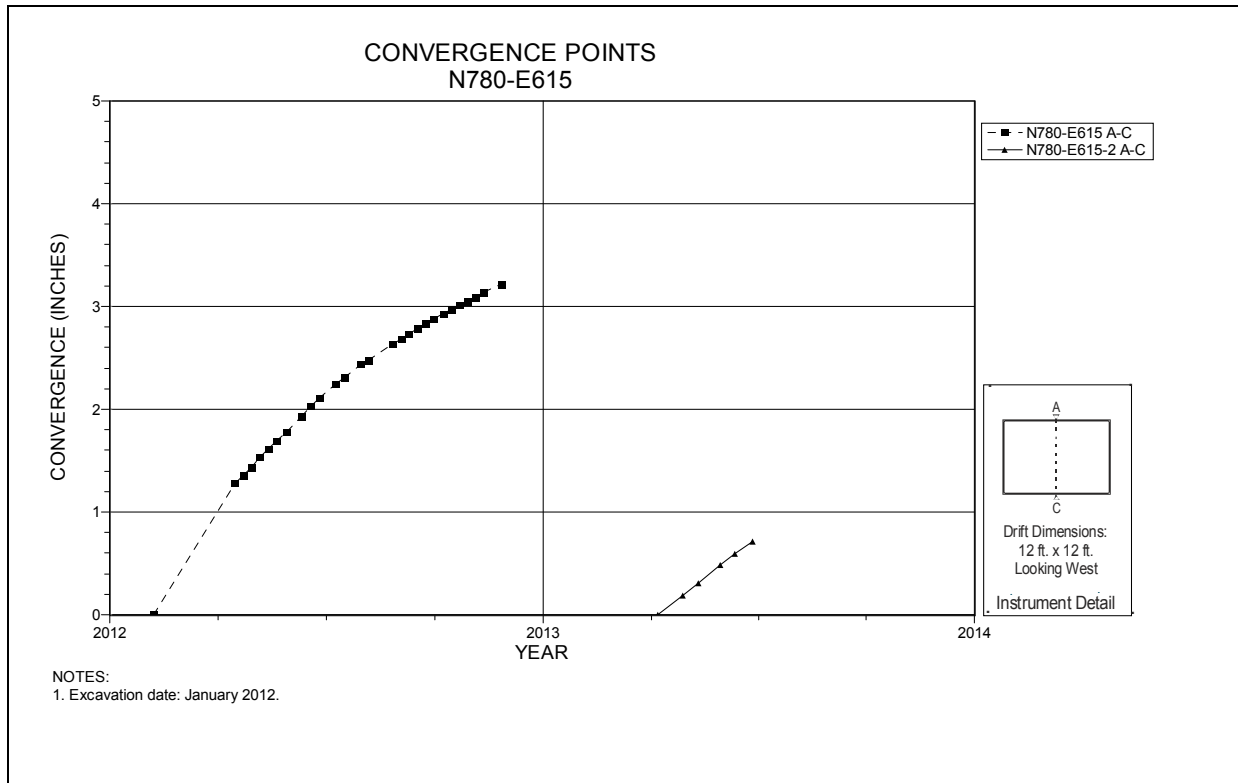

Figure 6-29 Convergence Point Array
N780 E615 – Roof to Floor

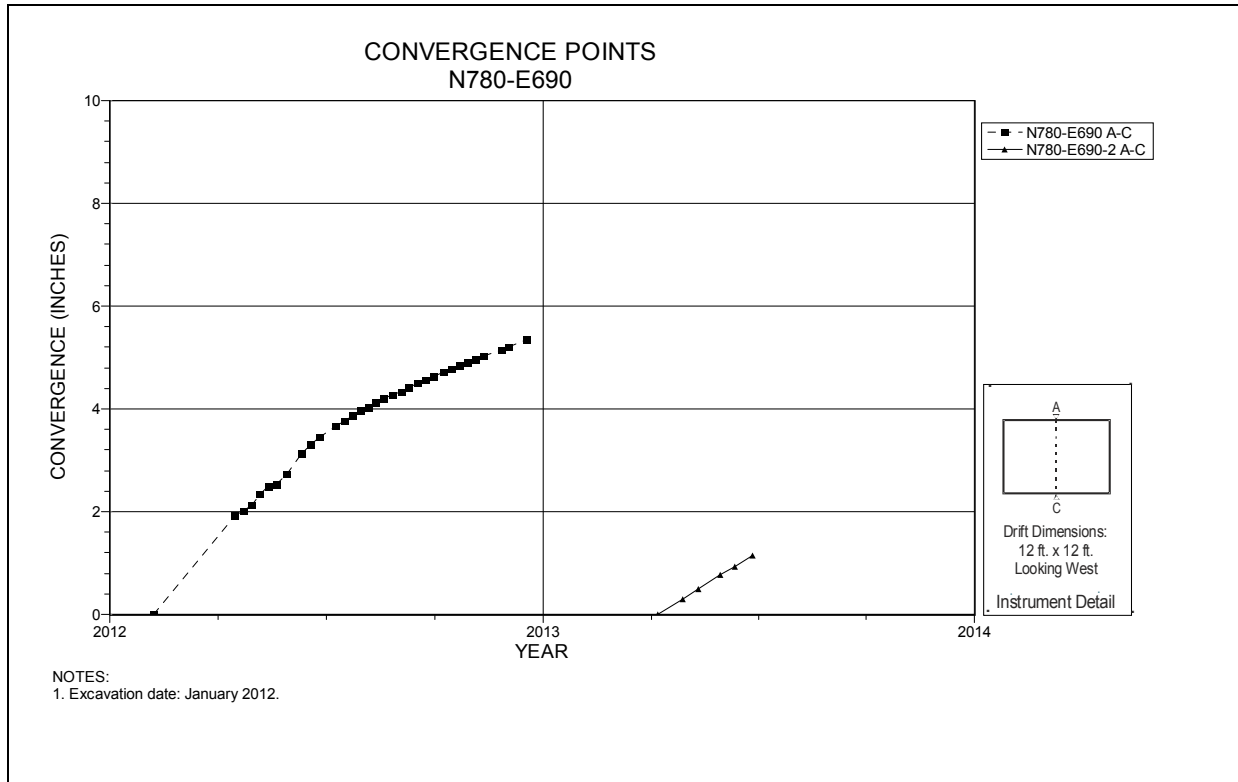

Figure 6-30 Convergence Point Array
N780 E690 – Roof to Floor

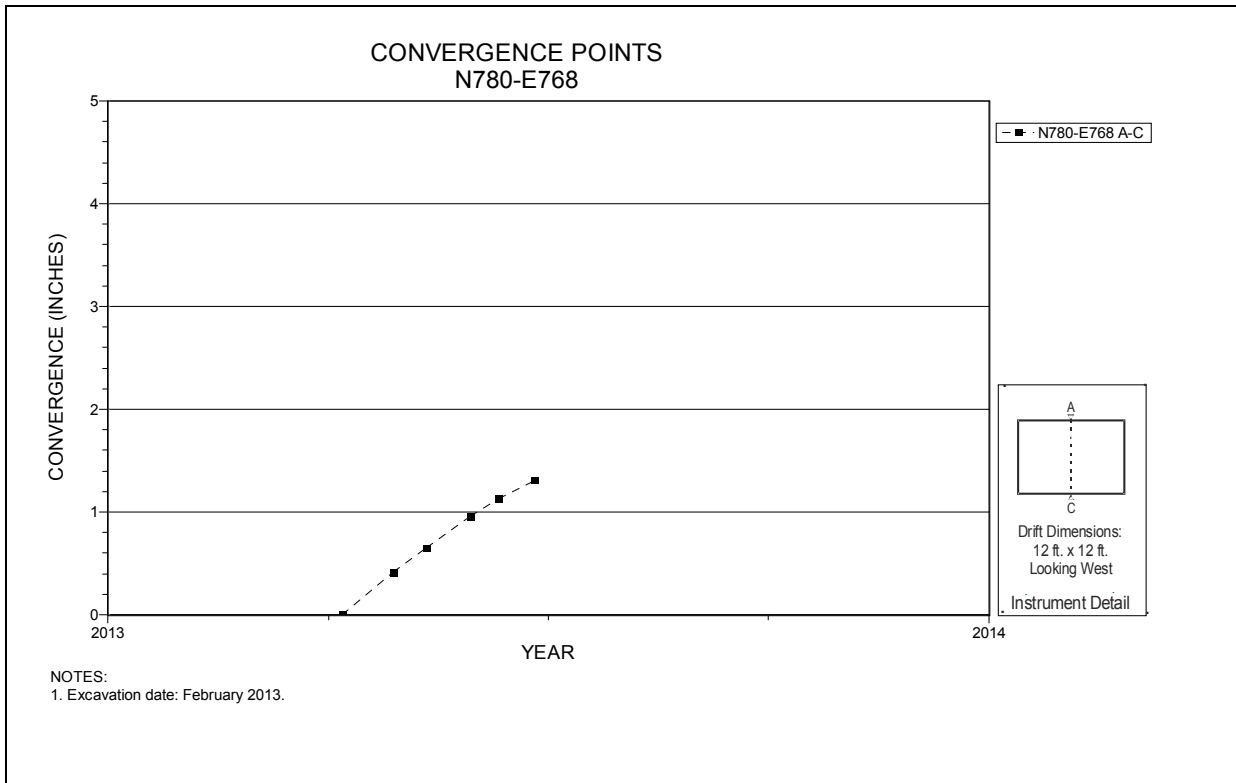

Figure 6-31 Convergence Point Array
N780 E768 – Roof to Floor

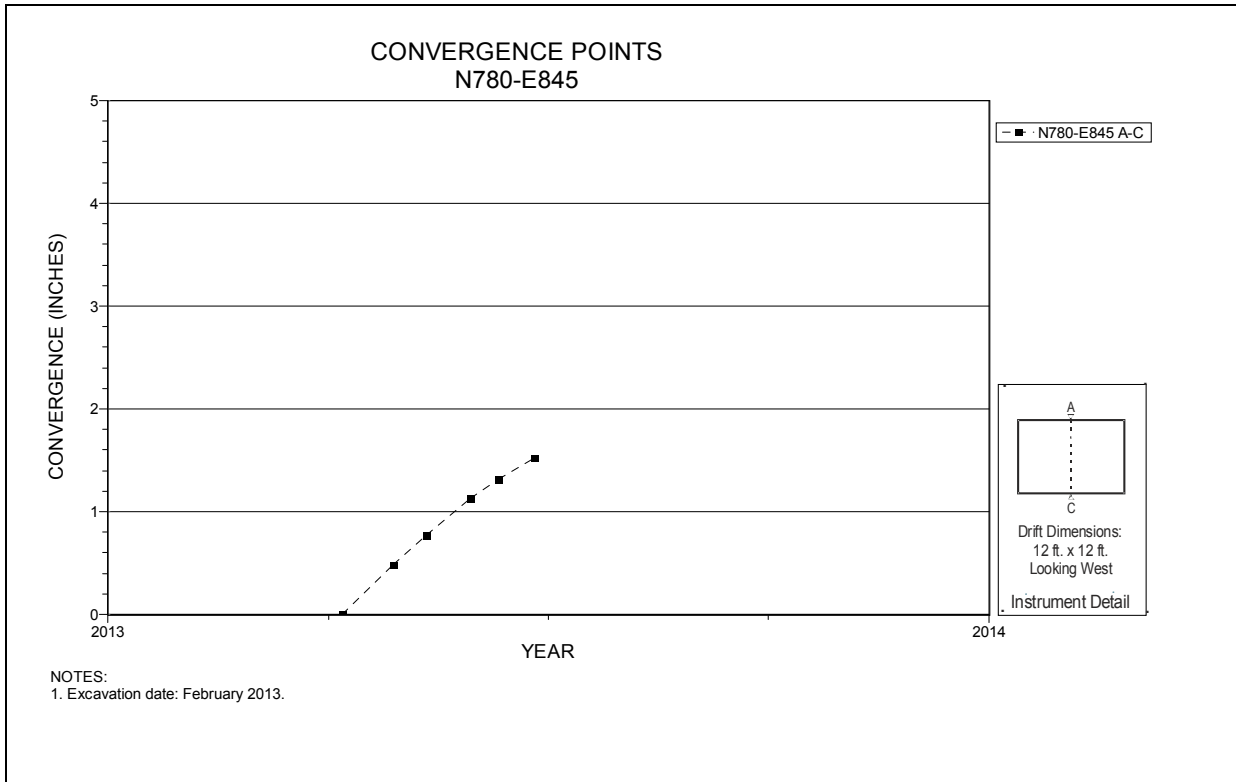
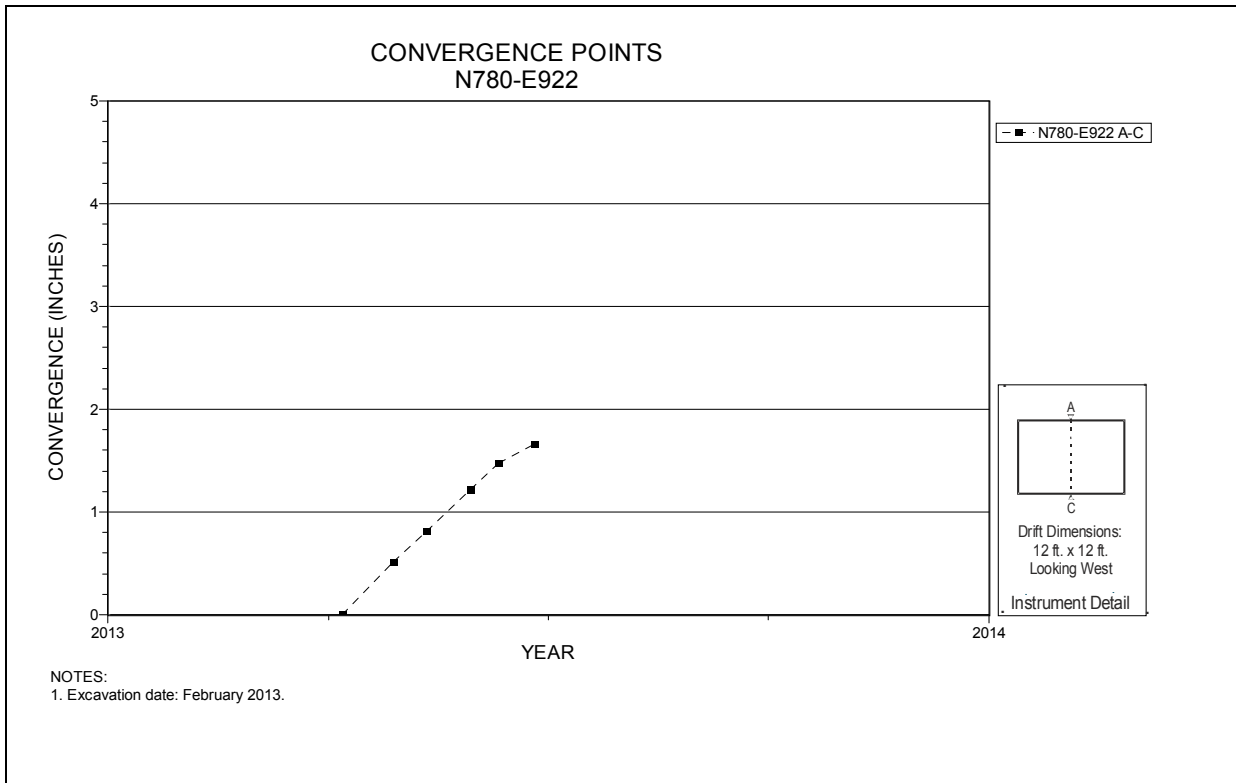
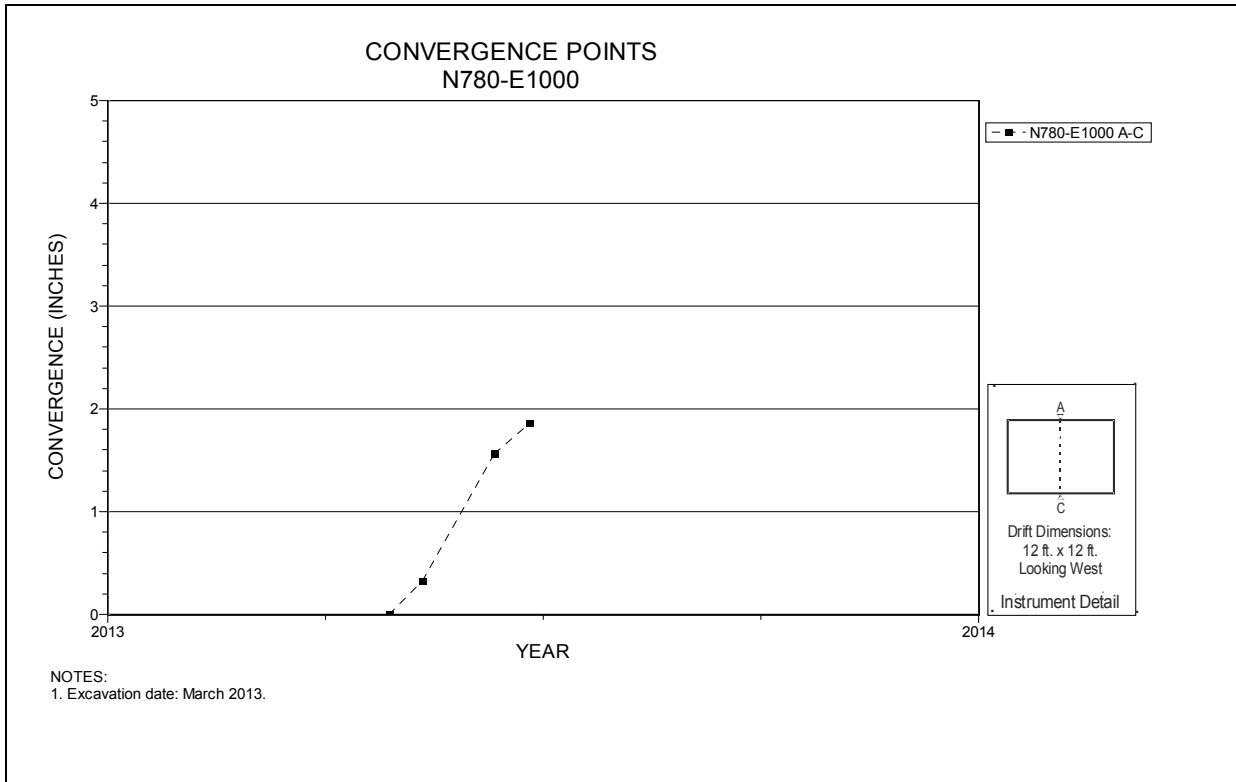

Figure 6-32 Convergence Point Array
N780 E845 – Roof to Floor



**Figure 6-33 Convergence Point Array
N780 E922 – Roof to Floor**



**Figure 6-34 Convergence Point Array
N780 E1000 – Roof to Floor**

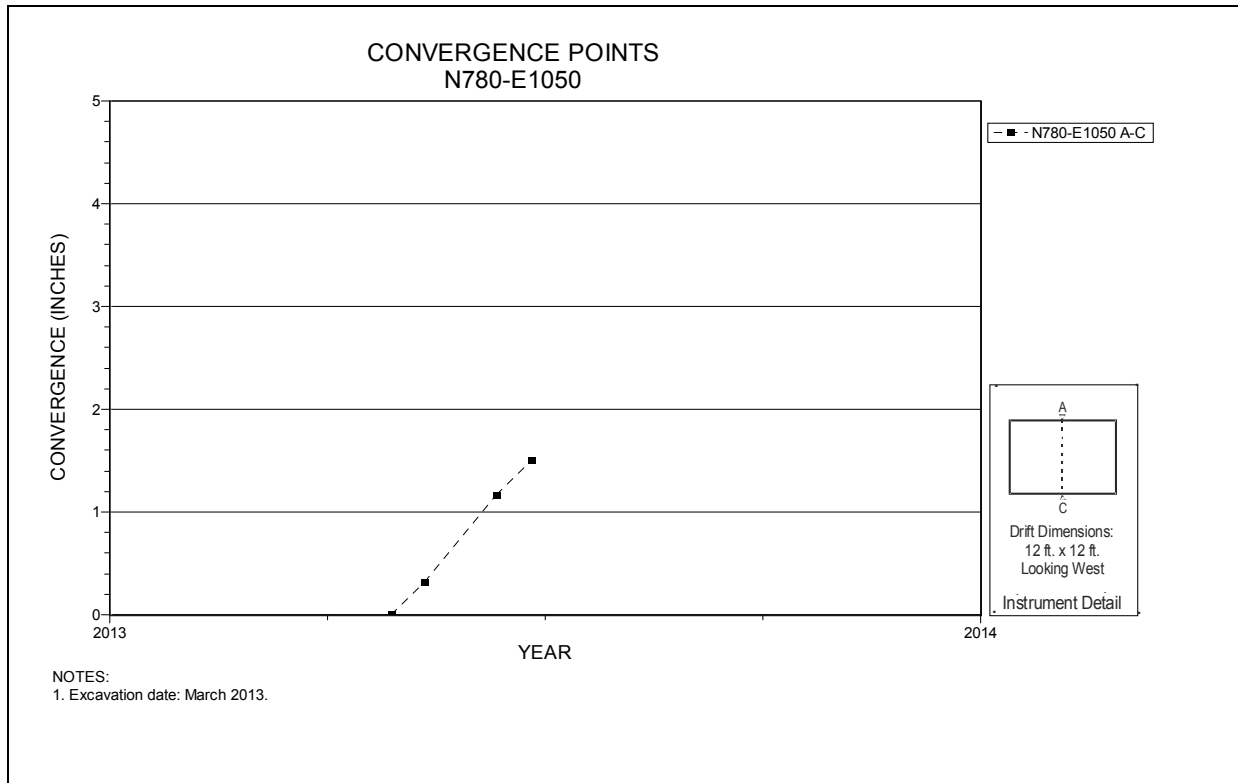

Figure 6-35 Convergence Point Array
N780 E1050 – Roof to Floor

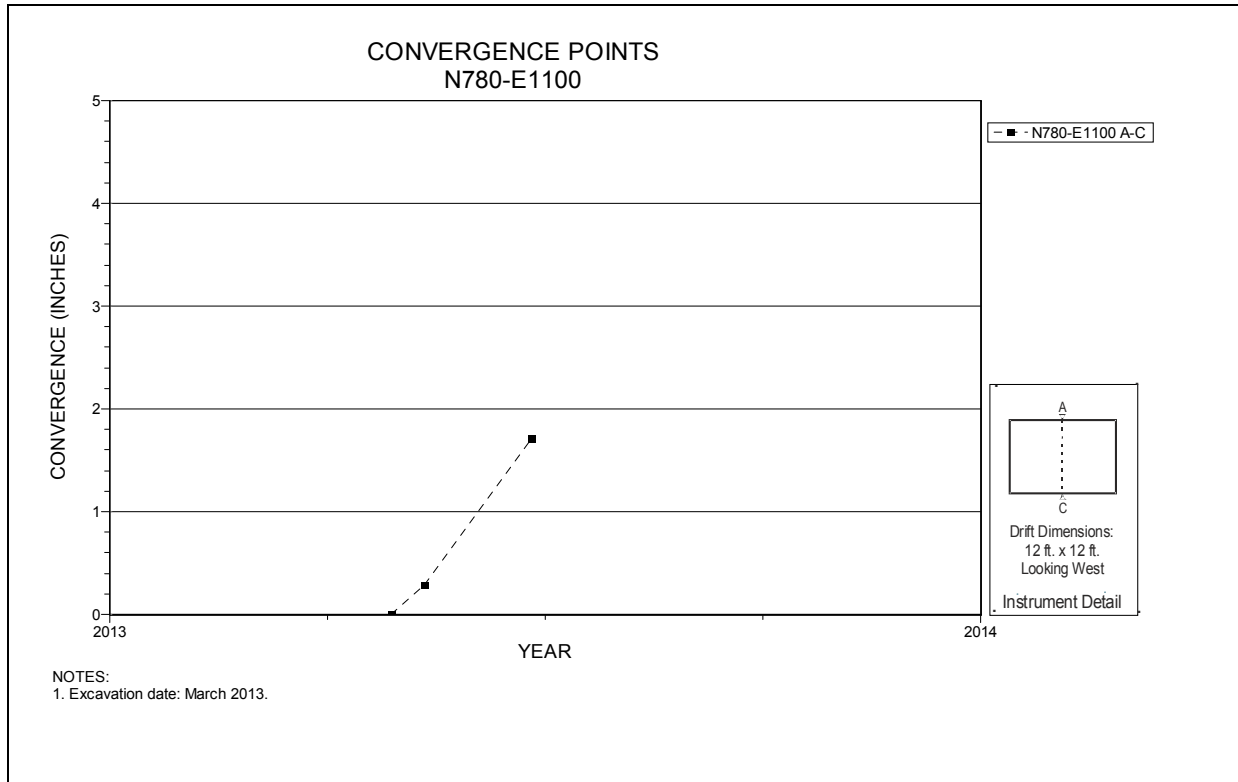

Figure 6-36 Convergence Point Array
N780 E1100 – Roof to Floor

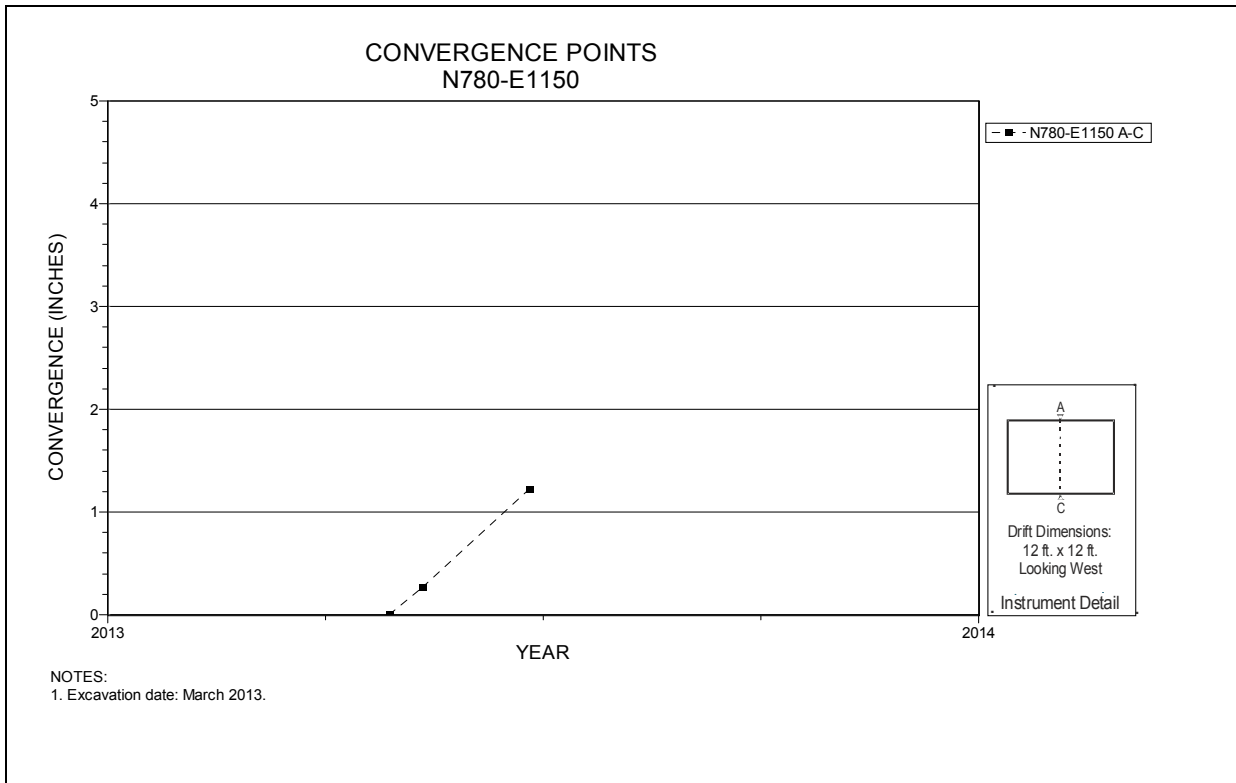

Figure 6-37 Convergence Point Array
N780 E1150 – Roof to Floor

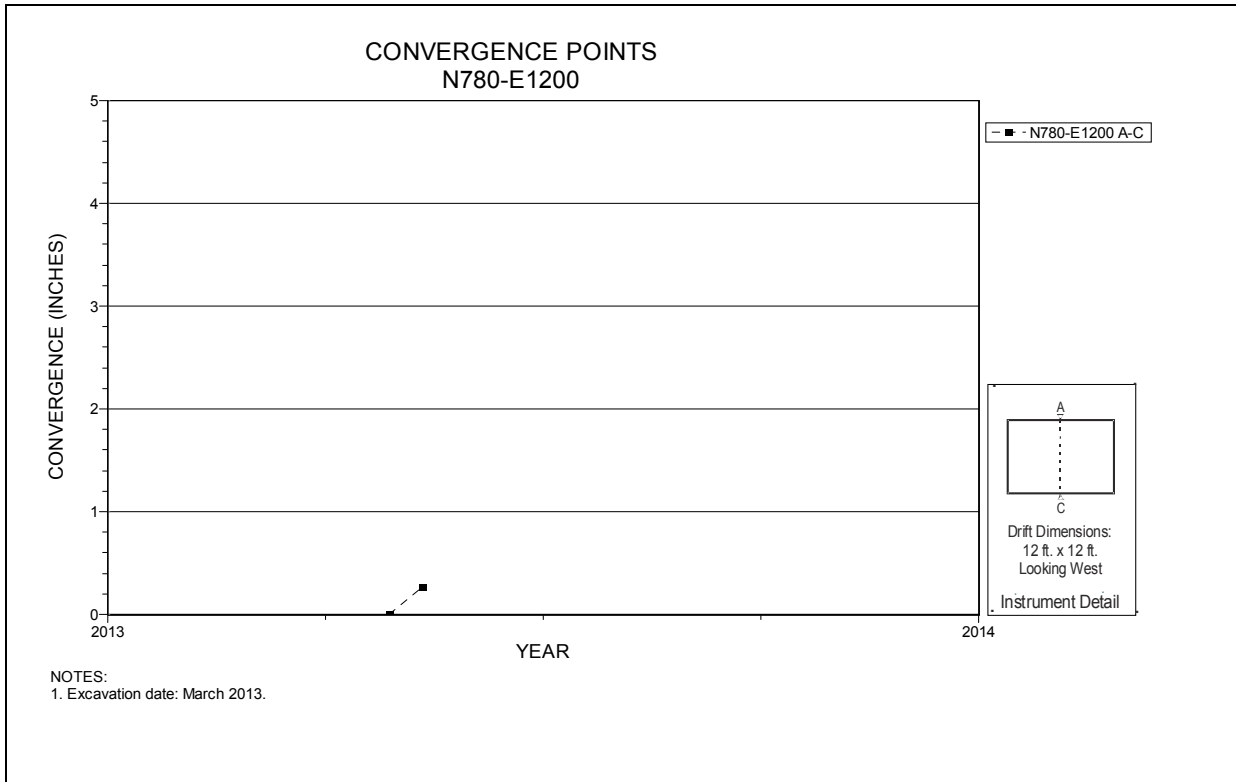

Figure 6-38 Convergence Point Array
N780 E1200 – Roof to Floor

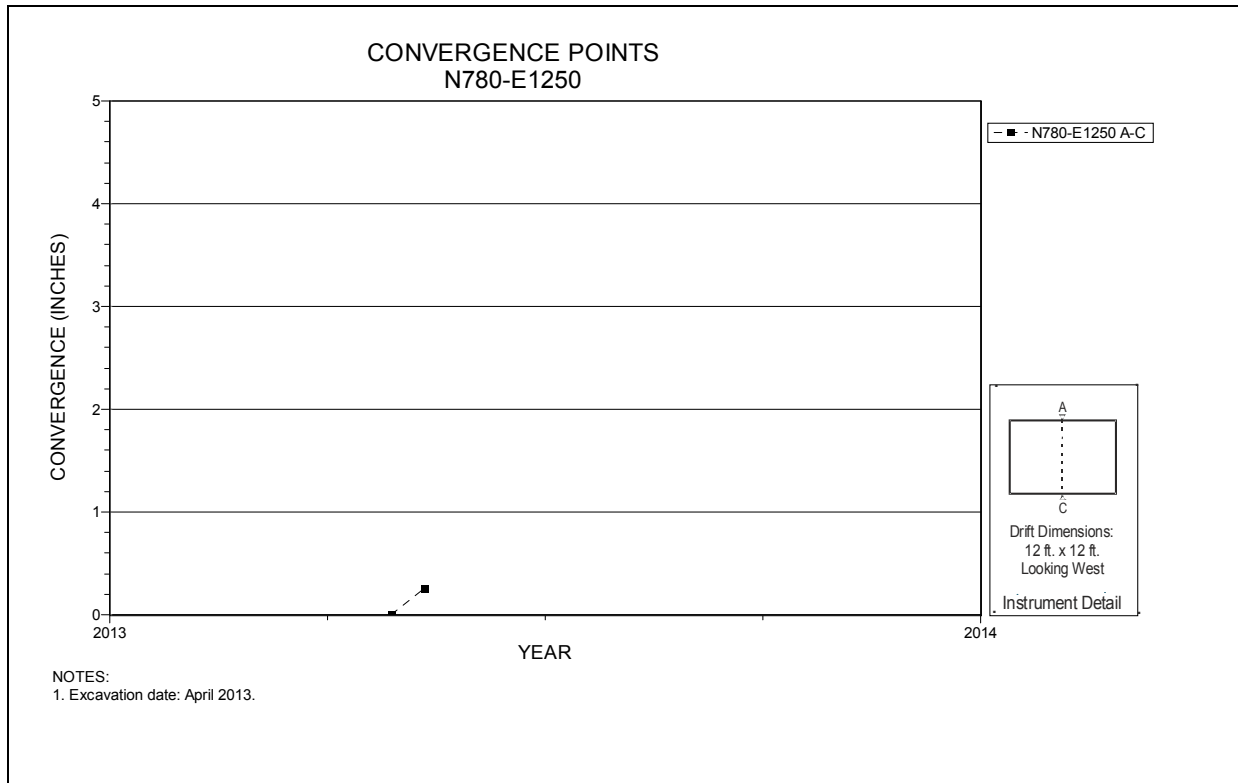

Figure 6-39 Convergence Point Array
N780 E1250 – Roof to Floor

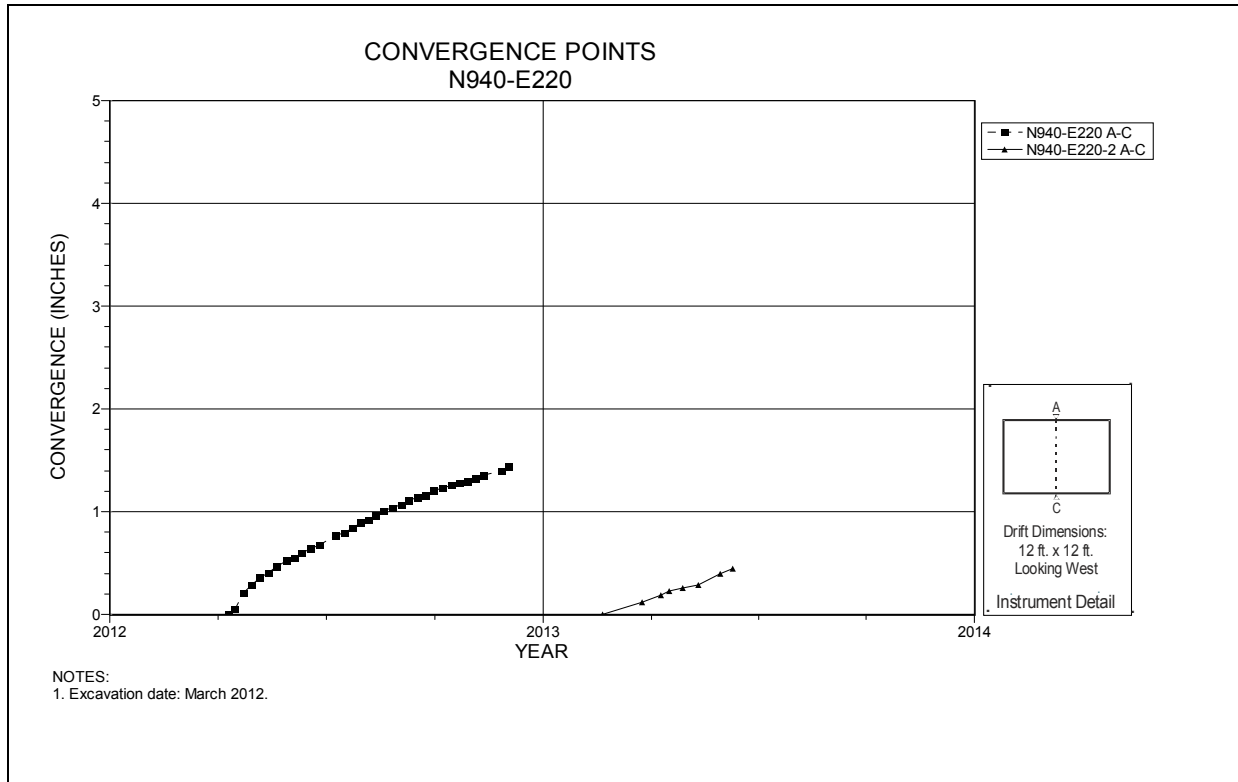

Figure 6-40 Convergence Point Array
N940 E220 – Roof to Floor

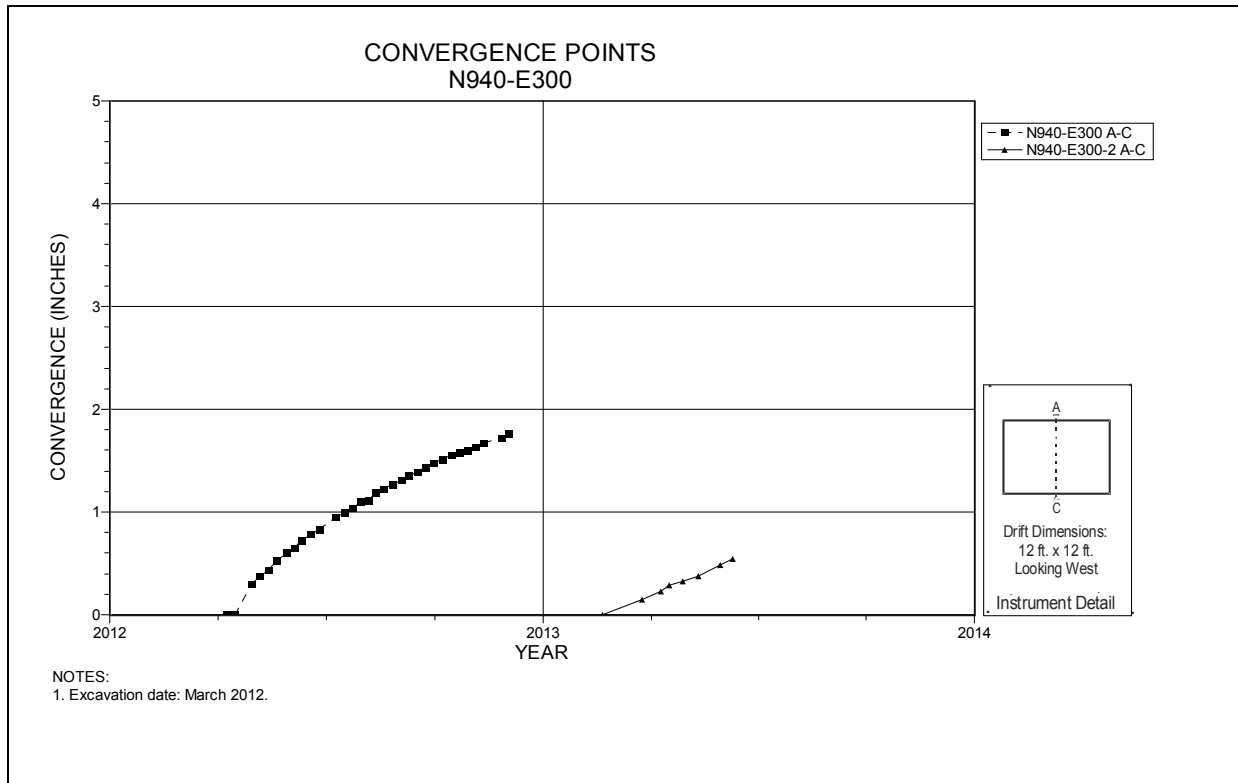

Figure 6-41 Convergence Point Array
N940 E300 – Roof to Floor

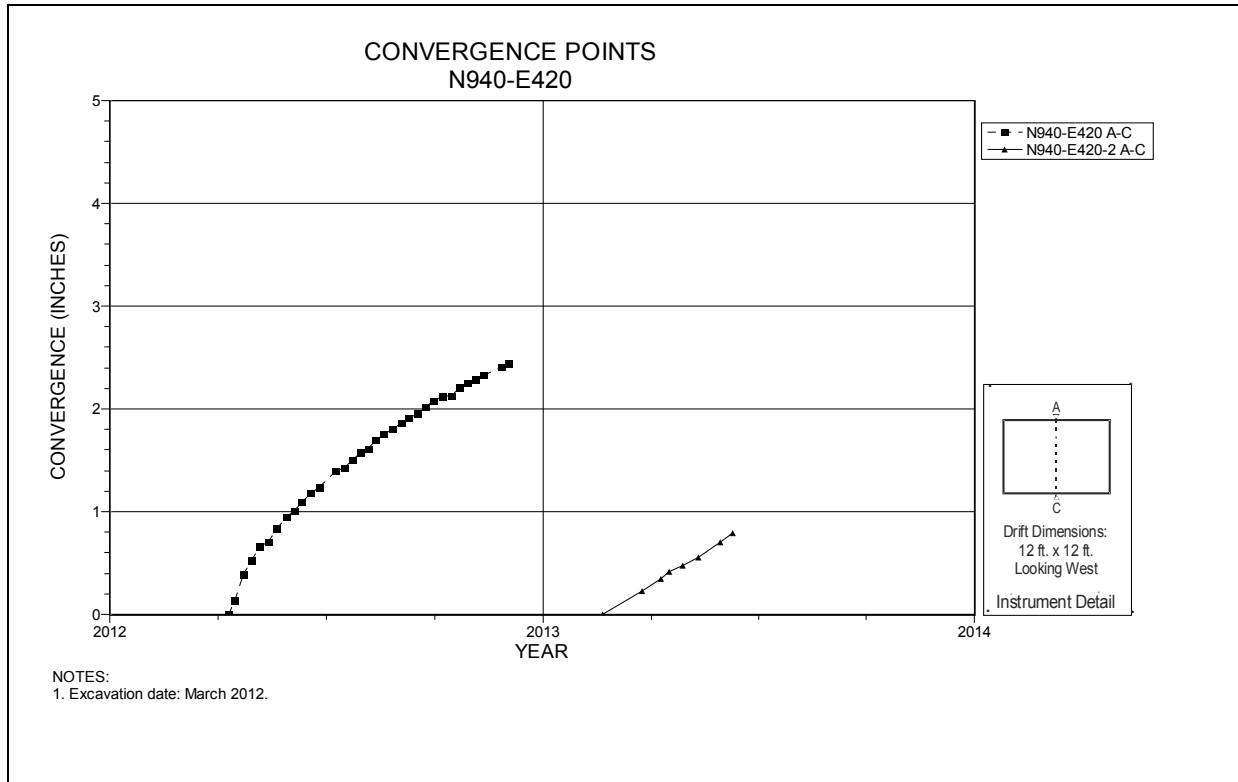

Figure 6-42 Convergence Point Array
N940 E420 – Roof to Floor

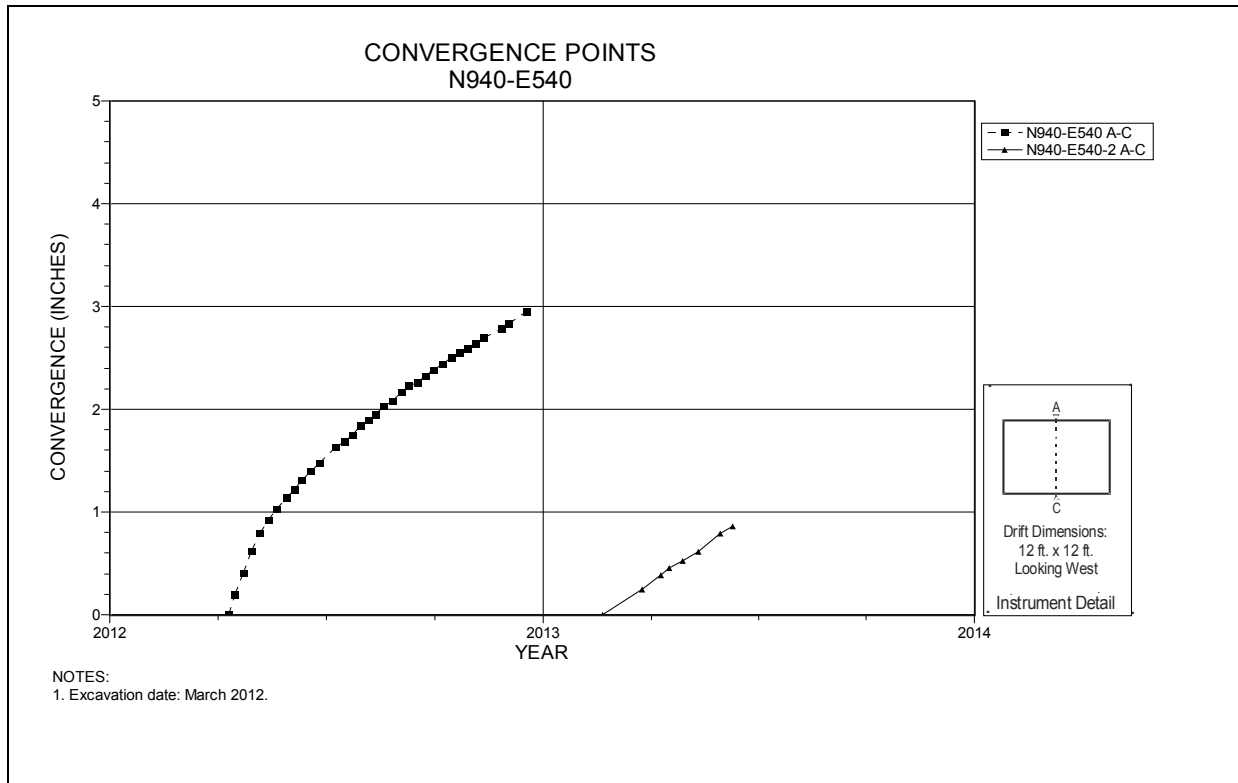

Figure 6-43 Convergence Point Array
N940 E540 – Roof to Floor

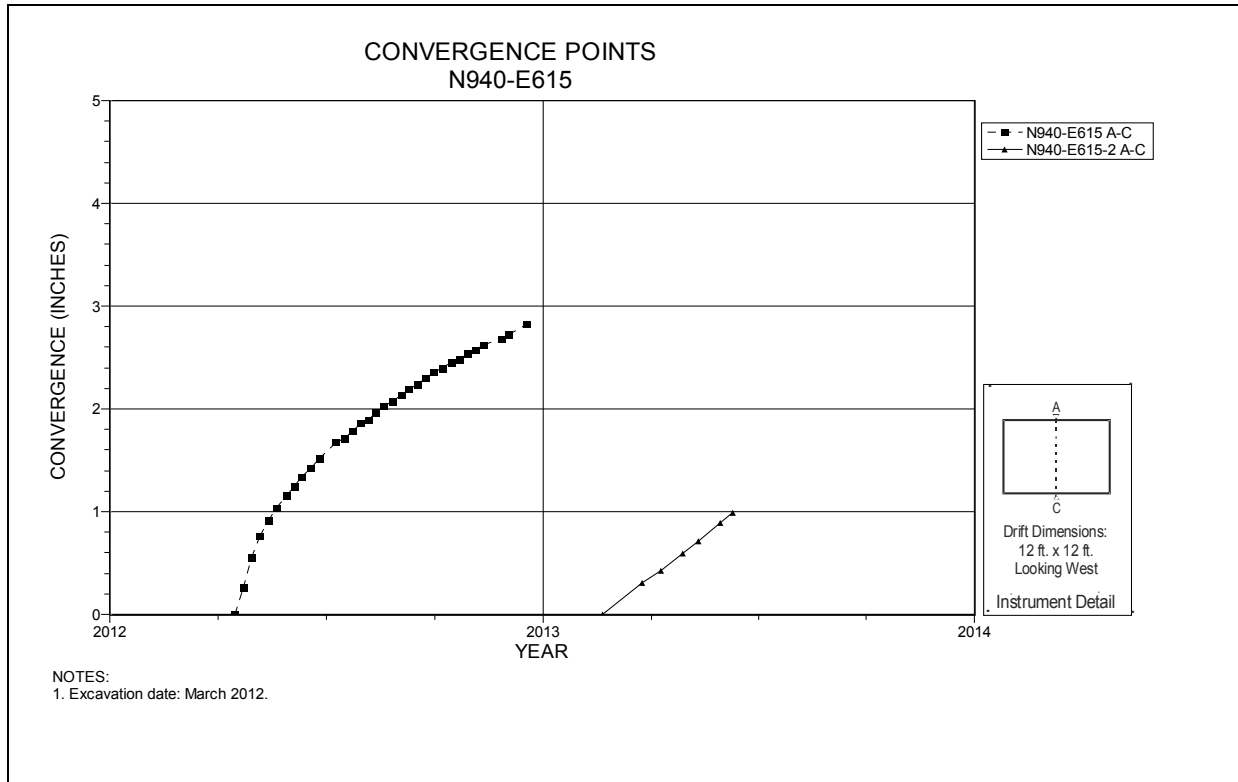

Figure 6-44 Convergence Point Array
N940 E615 – Roof to Floor

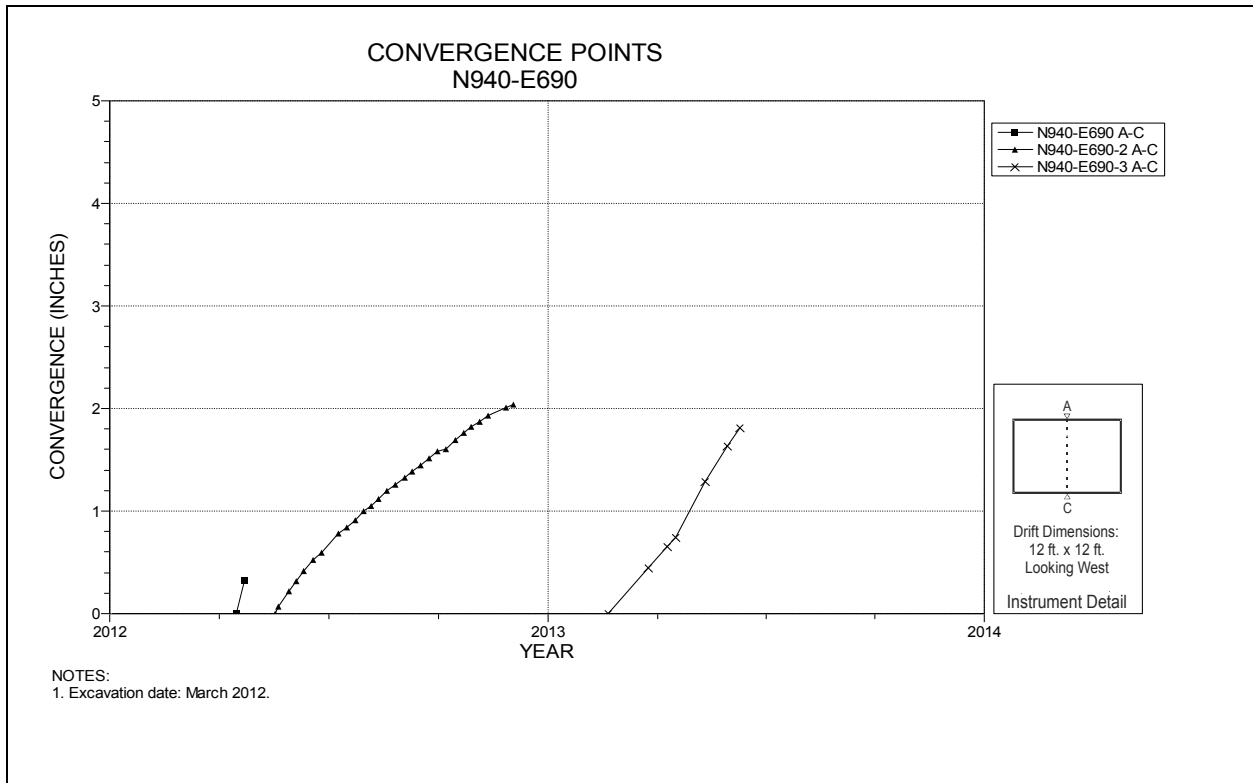

Figure 6-45 Convergence Point Array
N940 E690 – Roof to Floor

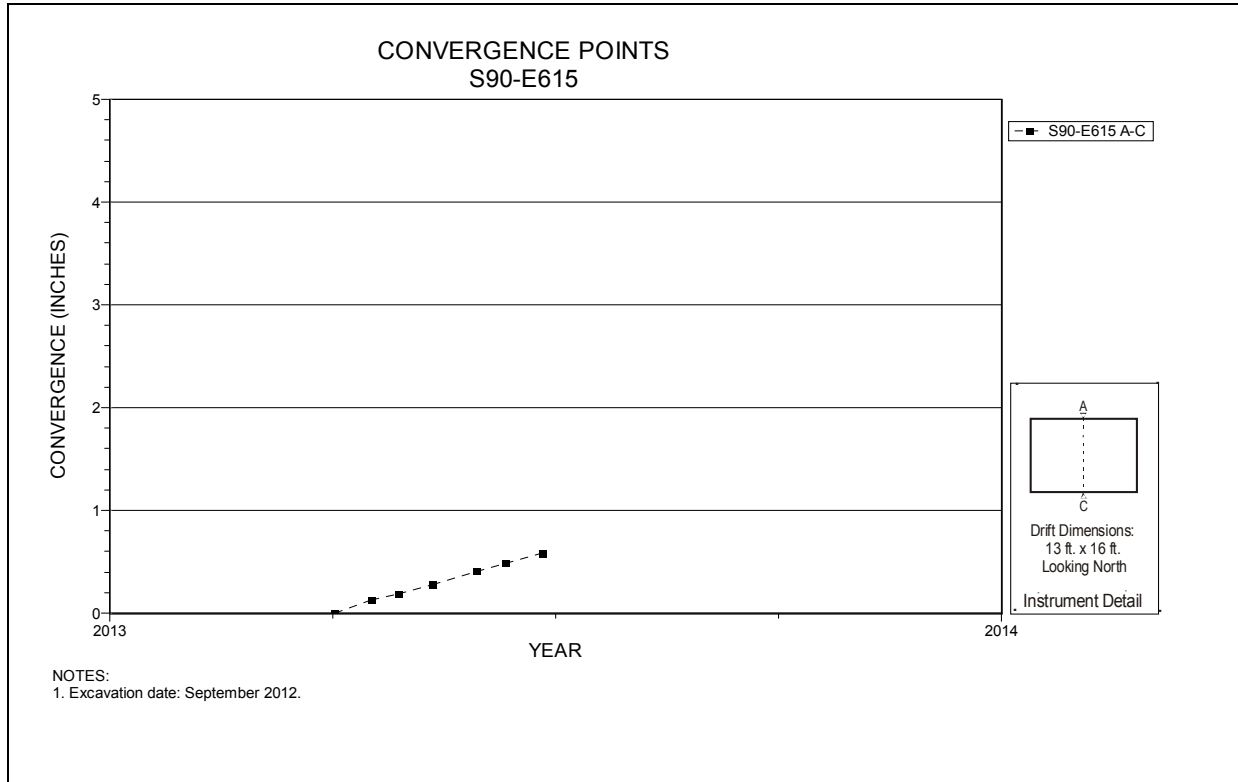

Figure 6-46 Convergence Point Array
S90 E615 – Roof to Floor

7.0 Geoscience Summary for the Waste Disposal Area

This chapter presents supporting data acquired as part of the Geoscience Program. It includes observations of clay seam displacements and other features in vertical observation holes, and fracture maps of excavation surfaces.

7.1 Borehole Inspections

This section presents a summary of the clay seam displacements (offsets) and fracture densities measured in observation boreholes located through the WIPP underground facility. Relative lateral displacement of rock strata above and below a clay layer is measured as offset within a borehole. Fracture density is a calculated parameter based on the number of fractures (separations) and fracture zones observed in an observation borehole. Fracture density is calculated to be the number of fractures plus twice the number of fracture zones in a roof beam divided by the thickness of the beam (in feet). Table 7-1 presents the observed offset data for boreholes, the observed fractures and fracture zones, and the calculated fracture densities.

7.2 Fracture Mapping

This section presents graphical results of the fracture mapping done in Panel 6 and Panel 7 of the Waste Disposal Area. Figures 7-1 through 7-46 are plan view fracture maps for the roof.

Table 7-1
Observation Borehole Fractures and Offset Data Summary

Hole	Location	Initial Inspection Date	Recent Inspection Date	FR ¹	FZ ²	Beam Height (ft)	Feature	Fracture Density ³	Feature Depth (ft)	Separation (in)	Offset (ft)	Compass	Hole Closure (%)	Offset Rate (in/yr)
OH485	E140-N1400	1/7/2004	6/4/2013	0	0	6.7	Hangup	0.0	6.7	0.00	1.75	S	58.3	0.19
OH485		1/7/2004	6/4/2013				BOH		16.3	0.00	0.00			
OH484	E140-N1265	1/7/2004	6/4/2013				Separation		1.6	0.25	0.19	W	6.3	0.02
OH484		1/7/2004	6/4/2013				Separation		2.7	0.13	0.00			
OH484		1/7/2004	6/4/2013	2	0	5.8	Separation	0.3	5.8	0.13	0.38	W	12.5	0.04
OH484		1/7/2004	6/4/2013				Separation		6.0	0.13	0.13	W	4.2	0.01
OH484		1/7/2004	6/4/2013				Separation		6.6	0.13	0.00			
OH484		1/7/2004	6/4/2013				BOH		20.6	0.00	0.00			
OH492	E140-N790	1/9/2004	6/4/2013	0	0	6.7	Separation	0.0	6.7	0.13	0.19	W	6.3	0.02
OH492		1/9/2004	6/4/2013				BOH		20.4	0.00	0.00			
OH523	E140-S164	11/20/2004	6/10/2013				Separation		5.7	0.13	0.00			
OH523		11/20/2004	6/10/2013				Separation		6.9	0.25	0.00			
OH523		11/20/2004	6/10/2013				Separation		7.4	0.25	0.00			
OH523		11/20/2004	6/10/2013	3	0	9.4	Separation	0.3	9.4	1.50	2.50	E	83.3	0.29
OH523		11/20/2004	6/10/2013				Hangup		6.4	0.00	2.00	E	66.7	0.23

¹ Number of fractures (FR) in immediate roof beam

² Number of fracture zones (FZ) in immediate roof beam

³ Fracture Density = (FR + 2 FZ)/Beam Height

Table 7-1
Observation Borehole Fractures and Offset Data Summary

Hole	Location	Initial Inspection Date	Recent Inspection Date	FR ¹	FZ ²	Beam Height (ft)	Feature	Fracture Density ³	Feature Depth (ft)	Separation (in)	Offset (ft)	Compass	Hole Closure (%)	Offset Rate (in/yr)
OH498-1	E140-S415	3/2/2009	6/10/2013	0	0	6.1	Separation	0.0	6.1	0.13	0.06	N	2.1	0.01
OH498-1		3/2/2009	6/10/2013				BOH		8.1	0.00	0.00			
OH499-1	E140-S520	3/2/2009	6/10/2013	0	0	5.9	Separation	0.0	5.9	0.13	0.00			
OH499-1		3/2/2009	6/10/2013				BOH		8.4	0.00	0.00			
OH620	E140-S700	11/17/2005	6/4/2013				Separation		3.2	0.13	0.00			
OH620		11/17/2005	6/4/2013				Separation		5.9	0.25	0.00			
OH620		11/17/2005	6/4/2013	2	0	6.1	Separation	0.3	6.1	0.13	0.00			
OH620		11/17/2005	6/4/2013				Hangup		13.3	0.00	0.00			
OH620		11/17/2005	6/4/2013				BOH		16.8	0.00	0.00			
OH750	E140-S773	9/29/2011	6/4/2013				Hangup		4.2	0.00	0.00			
OH750		9/29/2011	6/4/2013	0	0	4.3	Hangup	0.0	4.3	0.00	1.75	E	58.3	1.04
OH750		9/29/2011	6/4/2013				Separation		6.6	0.13	0.00			
OH750		9/29/2011	6/4/2013				BOH		20.8	0.00	0.00			
OH874-1	E140-S850	9/29/2011	6/4/2013				Separation		5.7	0.13	0.25	W	8.3	0.15
OH874-1		9/29/2011	6/4/2013	1	0	6.2	Separation	0.2	6.2	0.38	2.00	W	66.7	1.19
OH874-1		9/29/2011	6/4/2013				BOH		20.2	0.00	0.00			
OH751	E140-S920	9/21/2011	6/4/2013				Separation		3.5	0.13	0.00			
OH751		9/21/2011	6/4/2013				Separation		4.3	0.13	0.00			
OH751		9/21/2011	6/4/2013	2	0	4.8	Separation	0.4	4.8	0.50	2.00	W	66.7	1.17
OH751		9/21/2011	6/4/2013				BOH		20.6	0.00	0.00			

¹ Number of fractures (FR) in immediate roof beam

² Number of fracture zones (FZ) in immediate roof beam

³ Fracture Density = (FR + 2 FZ)/Beam Height

Table 7-1
Observation Borehole Fractures and Offset Data Summary

Hole	Location	Initial Inspection Date	Recent Inspection Date	FR ¹	FZ ²	Beam Height (ft)	Feature	Fracture Density ³	Feature Depth (ft)	Separation (in)	Offset (ft)	Compass	Hole Closure (%)	Offset Rate (in/yr)
OH575-1	E140-S1000	9/29/2011	6/4/2013	0	0	4.2	Separation	0.0	4.2	0.75	1.00	E	33.3	0.59
OH575-1		9/29/2011	6/4/2013				Separation		6.0	0.13	0.00			
OH575-1		9/29/2011	6/4/2013				BOH		20.8	0.00	0.00			
OH752	E140-S1070	9/29/2011	6/4/2013				Separation		1.5	0.13	0.00			
OH752		9/29/2011	6/4/2013				Separation		5.6	0.13	0.00			
OH752		9/29/2011	6/4/2013	2	0	9.4	Hangup	0.2	9.4	0.00	0.00			
OH752		9/29/2011	6/4/2013				Separation		6.4	0.13	0.00			
OH752		9/29/2011	6/4/2013				BOH		20.6	0.00	0.00			
OH873-1	E140-S1145	9/29/2011	6/4/2013				Separation		1.0	0.13	0.00			
OH873-1		9/29/2011	6/4/2013				Separation		1.5	2.00	0.00			
OH873-1		9/29/2011	6/4/2013				Separation		2.0	0.50	0.00			
OH873-1		9/29/2011	6/4/2013				Separation		4.0	2.25	0.00			
OH873-1		9/29/2011	6/4/2013				Separation		5.0	0.13	0.00			
OH873-1		9/29/2011	6/4/2013	5	0	5.5	Separation	0.9	5.5	2.25	0.00			
OH873-1		9/29/2011	6/4/2013				BOH		6.2	0.00	3.00	E	100.0	1.78

¹ Number of fractures (FR) in immediate roof beam

² Number of fracture zones (FZ) in immediate roof beam

³ Fracture Density = (FR + 2 FZ)/Beam Height

Table 7-1
Observation Borehole Fractures and Offset Data Summary

Hole	Location	Initial Inspection Date	Recent Inspection Date	FR ¹	FZ ²	Beam Height (ft)	Feature	Fracture Density ³	Feature Depth (ft)	Separation (in)	Offset (ft)	Compass	Hole Closure (%)	Offset Rate (in/yr)
OH753	E140-S1226	9/29/2011	6/4/2013				Separation		1.3	0.25	0.00			
OH753		9/29/2011	6/4/2013				Separation		4.0	0.13	0.00			
OH753		9/29/2011	6/4/2013				Separation		4.3	0.13	0.00			
OH753		9/29/2011	6/4/2013	3	0	4.7	Separation	0.6	4.7	0.13	2.00	E	66.7	1.19
OH753		9/29/2011	6/4/2013				Separation		7.0	0.13	0.00			
OH753		9/29/2011	6/4/2013				Separation		7.3	0.13	0.00			
OH753		9/29/2011	6/4/2013				BOH		20.9	0.00	0.00			
OH578	E140-S1300	6/16/2005	6/4/2013				Separation		6.3	0.13	0.06	N	2.1	0.01
OH578		6/16/2005	6/4/2013				BOH		20.3	0.00	0.00			
OH578		6/16/2005	6/4/2013	1	0	6.1	Separation	0.0	6.1	0.13	0.06	W	2.1	0.01
OH872-1	E140-S1390	3/2/2009	6/4/2013				Separation		1.5	0.13	0.06	W	2.1	0.01
OH872-1		3/2/2009	6/4/2013				Separation		2.0	0.13	0.06	W	2.1	0.01
OH872-1		3/2/2009	6/4/2013				Separation		2.9	0.13	0.06	W	2.1	0.01
OH872-1		3/2/2009	6/4/2013				Separation		4.4	0.25	0.06	W	2.1	0.01
OH872-1		3/2/2009	6/4/2013				Separation		5.6	3.50	0.19	E	6.3	0.04
OH872-1		3/2/2009	6/4/2013				Separation		6.0	0.13	0.13	W	4.2	0.03
OH872-1		3/2/2009	6/4/2013	6	0	6.4	Separation	0.9	6.4	0.13	0.38	W	12.5	0.09
OH872-1		3/2/2009	6/4/2013				Separation		7.2	0.13	0.00			
OH872-1		3/2/2009	6/4/2013				BOH		20.2	0.00	0.00			

¹ Number of fractures (FR) in immediate roof beam

² Number of fracture zones (FZ) in immediate roof beam

³ Fracture Density = (FR + 2 FZ)/Beam Height

Table 7-1
Observation Borehole Fractures and Offset Data Summary

Hole	Location	Initial Inspection Date	Recent Inspection Date	FR ¹	FZ ²	Beam Height (ft)	Feature	Fracture Density ³	Feature Depth (ft)	Separation (in)	Offset (ft)	Compass	Hole Closure (%)	Offset Rate (in/yr)
OH580-2	E140-S1463	3/2/2009	6/4/2013				Separation		1.0	0.13	0.06	W	2.1	0.01
OH580-2		3/2/2009	6/4/2013				Separation		1.5	0.13	0.00			
OH580-2		3/2/2009	6/4/2013				Separation		2.5	2.00	0.06	W	2.1	0.01
OH580-2		3/2/2009	6/4/2013				Separation		3.4	0.13	0.00			
OH580-2		3/2/2009	6/4/2013				Separation		3.9	0.50	0.00			
OH580-2		3/2/2009	6/4/2013				Separation		4.2	2.50	0.13	E	4.2	0.03
OH580-2		3/2/2009	6/4/2013				Separation		4.7	2.50	0.00			
OH580-2		3/2/2009	6/4/2013	7	0	5.2	Separation	1.3	5.2	3.75	0.75	W	25.0	0.18
OH580-2		3/2/2009	6/4/2013				Separation		5.7	0.13	0.00			
OH580-2		3/2/2009	6/4/2013				Separation		7.5	0.50	0.00			
OH580-2		3/2/2009	6/4/2013				Separation		20.7	0.00	0.00			
OH754	E140-S1526	9/29/2011	4/2/2013				Separation		1.2	2.50	0.00			
OH754		9/29/2011	4/2/2013				Separation		1.8	7.00	0.00			
OH754		9/29/2011	4/2/2013	2	0	6.8	Separation	0.3	6.8	5.00	0.00			
OH754		9/29/2011	4/2/2013				Hole Closed		7.2	0.00	3.00	E	100.0	1.99

¹ Number of fractures (FR) in immediate roof beam

² Number of fracture zones (FZ) in immediate roof beam

³ Fracture Density = (FR + 2 FZ)/Beam Height

Observation Borehole Fractures and Offset Data Summary

Hole	Location	Initial Inspection Date	Recent Inspection Date	FR ¹	FZ ²	Beam Height (ft)	Feature	Fracture Density ³	Feature Depth (ft)	Separation (in)	Offset (ft)	Compass	Hole Closure (%)	Offset Rate (in/yr)
OH582	E140-S1600	6/16/2005	6/3/2013				Rough Spot		6.2	0.00	0.00			
OH582		6/16/2005	6/3/2013	0	0	6.8	Rough Spot	0.0	6.8	0.00	0.00			
OH582		6/16/2005	6/3/2013				BOH		20.4	0.00	0.00			
OH871-1	E140-S1680	9/29/2011	4/2/2013				Separation		1.6	2.00	0.00			
OH871-1		9/29/2011	4/2/2013				Separation		2.8	2.00	0.00			
OH871-1		9/29/2011	4/2/2013				Separation		4.0	0.13	0.00			
OH871-1		9/29/2011	4/2/2013				Separation		5.0	0.38	0.00			
OH871-1		9/29/2011	4/2/2013	4	0	5.6	Separation	0.7	5.6	5.00	3.00	W	100.0	1.99
OH583	E140-S1950	6/16/2005	6/3/2013				Separation		1.9	0.13	0.25	E	8.3	0.03
OH583		6/16/2005	6/3/2013				Separation		3.0	0.06	0.00			
OH583		6/16/2005	6/3/2013				Separation		5.0	0.13	0.00			
OH583		6/16/2005	6/3/2013				Separation		5.7	0.13	0.19	E	6.3	0.02
OH583		6/16/2005	6/3/2013	4	0	6.2	Separation	0.6	6.2	2.00	2.00	E	66.7	0.25
OH583		6/16/2005	6/3/2013				Separation		6.9	0.13	0.00			
OH583		6/16/2005	6/3/2013				BOH		20.8	0.00	0.00			

¹ Number of fractures (FR) in immediate roof beam

² Number of fracture zones (FZ) in immediate roof beam

³ Fracture Density = (FR + 2 FZ)/Beam Height

Table 7-1
Observation Borehole Fractures and Offset Data Summary

Hole	Location	Initial Inspection Date	Recent Inspection Date	FR ¹	FZ ²	Beam Height (ft)	Feature	Fracture Density ³	Feature Depth (ft)	Separation (in)	Offset (ft)	Compass	Hole Closure (%)	Offset Rate (in/yr)
OH472-2	E140-S2167	9/26/2011	4/2/2013				Separation		4.9	0.13	0.00			
OH472-2		9/26/2011	4/2/2013				Separation		5.4	0.13	0.13	SE	4.2	0.08
OH472-2		9/26/2011	4/2/2013	2	0	6.5	Separation	0.3	6.5	0.75	0.00			
OH472-2		9/26/2011	4/2/2013				Separation		6.6	0.13	0.00			
OH472-2		9/26/2011	4/2/2013				BOH		20.3	0.00	0.00			
OH870	E140-S2435	9/26/2011	6/3/2013				Separation		1.2	0.13	0.06	W	2.1	0.04
OH870		9/26/2011	6/3/2013				Separation		1.7	0.38	0.06	W	2.1	0.04
OH870		9/26/2011	6/3/2013				Separation		2.6	0.50	0.13	W	4.2	0.07
OH870		9/26/2011	6/3/2013	3	0	4.6	Separation	0.7	4.6	11.00	1.50	E	50.0	0.89
OH870		9/26/2011	6/3/2013				Separation		7.3	0.13	1.25	W	41.7	0.74
OH870		9/26/2011	6/3/2013				BOH		20.5	0.00	0.00			
OH588-1	E140-S2520	9/26/2011	12/18/2012				Separation		1.6	0.13	0.00			
OH588-1		9/26/2011	12/18/2012	1	0	5.3	Separation	0.2	5.3	2.50	0.75	E	25.0	0.61
OH588-1		9/26/2011	12/18/2012				Separation		6.2	0.13	0.00			
OH588-1		9/26/2011	12/18/2012				BOH		20.6	0.00	0.00			
OH589-1	E140-S2750	3/15/2009	6/3/2013	0	0	5.3	Separation	0.0	5.3	0.13	0.50	N	16.7	0.12
OH589-1		3/15/2009	6/3/2013				Separation		5.7	0.13	0.00			
OH589-1		3/15/2009	6/3/2013				Hangup		6.6	0.00	0.00			
OH589-1		3/15/2009	6/3/2013				Hangup		8.0	0.00	0.00			
OH589-1		3/15/2009	6/3/2013				BOH		20.5	0.00	0.00			

¹ Number of fractures (FR) in immediate roof beam

² Number of fracture zones (FZ) in immediate roof beam

³ Fracture Density = (FR + 2 FZ)/Beam Height

**Table 7-1
Observation Borehole Fractures and Offset Data Summary**

Hole	Location	Initial Inspection Date	Recent Inspection Date	FR ¹	FZ ²	Beam Height (ft)	Feature	Fracture Density ³	Feature Depth (ft)	Separation (in)	Offset (ft)	Compass	Hole Closure (%)	Offset Rate (in/yr)
OH500-2	E140-S2920	9/26/2011	12/18/2012				Separation		1.0	1.25	0.06	W	2.1	0.05
OH500-2		9/26/2011	12/18/2012				Separation		2.0	0.13	0.06	W	2.1	0.05
OH500-2		9/26/2011	12/18/2012				Separation		4.7	0.13	0.00			
OH500-2		9/26/2011	12/18/2012				Separation		5.2	2.00	0.00			
OH500-2		9/26/2011	12/18/2012	4	0	5.7	Separation	0.7	5.7	1.50	1.50	E	50.0	1.22
OH500-2		9/26/2011	12/18/2012				Separation		5.9	0.75	0.00			
OH500-2		9/26/2011	12/18/2012				Separation		6.1	4.00	2.25	E	75.0	1.83
OH500-2		9/26/2011	12/18/2012				Separation		7.9	2.00	0.00			
OH500-2		9/26/2011	12/18/2012				BOH		20.6	0.00	0.00			

¹ Number of fractures (FR) in immediate roof beam

² Number of fracture zones (FZ) in immediate roof beam

³ Fracture Density = (FR + 2 FZ)/Beam Height

Table 7-1
Observation Borehole Fractures and Offset Data Summary

Hole	Location	Initial Inspection Date	Recent Inspection Date	FR ¹	FZ ²	Beam Height (ft)	Feature	Fracture Density ³	Feature Depth (ft)	Separation (in)	Offset (ft)	Compass	Hole Closure (%)	Offset Rate (in/yr)
OH501-2	E140-S2935	9/26/2011	9/7/2012				Separation		0.8	1.00	0.13	E	4.2	0.13
OH501-2		9/26/2011	9/7/2012				Separation		1.8	3.25	0.19	E	6.3	0.20
OH501-2		9/26/2011	9/7/2012				Separation		5.0	0.13	0.00			
OH501-2		9/26/2011	9/7/2012				Separation		5.4	0.13	0.00			
OH501-2		9/26/2011	9/7/2012	4	0	5.6	Separation	0.7	5.6	0.13	2.25	E	75.0	2.37
OH501-2		9/26/2011	9/7/2012				Separation		5.8	2.00	0.00			
OH501-2		9/26/2011	9/7/2012				Separation		6.1	0.13	0.00			
OH501-2		9/26/2011	9/7/2012				Separation		6.2	0.13	0.00			
OH501-2		9/26/2011	9/7/2012				Separation		6.5	0.13	0.00			
OH501-2		9/26/2011	9/7/2012				Separation		6.7	1.00	0.00			
OH501-2		9/26/2011	9/7/2012				Separation		7.3	6.00	0.00			
OH501-2		9/26/2011	9/7/2012				Separation		7.8	4.00	0.00			
OH501-2		9/26/2011	9/7/2012				Separation		20.6	0.00	0.00			

¹ Number of fractures (FR) in immediate roof beam

² Number of fracture zones (FZ) in immediate roof beam

³ Fracture Density = (FR + 2 FZ)/Beam Height

Table 7-1
Observation Borehole Fractures and Offset Data Summary

Hole	Location	Initial Inspection Date	Recent Inspection Date	FR ¹	FZ ²	Beam Height (ft)	Feature	Fracture Density ³	Feature Depth (ft)	Separation (in)	Offset (ft)	Compass	Hole Closure (%)	Offset Rate (in/yr)
OH590-1	E140-S3080	3/15/2009	6/3/2013				Separation		1.5	1.50	0.38	S	12.5	0.09
OH590-1		3/15/2009	6/3/2013				Separation		2.3	0.06	0.06	E	2.1	0.01
OH590-1		3/15/2009	6/3/2013				Separation		5.3	0.13	0.13	W	4.2	0.03
OH590-1		3/15/2009	6/3/2013	3	0	5.5	Separation	0.5	5.5	1.00	0.75	E	25.0	0.18
OH590-1		3/15/2009	6/3/2013				Separation		5.9	1.25	0.00			
OH590-1		3/15/2009	6/3/2013				Separation		6.2	2.00	0.50	S	16.7	0.12
OH590-1		3/15/2009	6/3/2013				Separation		6.6	0.25	0.00			
OH590-1		3/15/2009	6/3/2013				Separation		7.9	0.13	0.00			
OH590-1		3/15/2009	6/3/2013				BOH		20.6	0.00	0.00			
OH493-2	E140-S3199	9/26/2011	3/25/2013				Separation		0.9	2.00	0.75	W	25.0	0.50
OH493-2		9/26/2011	3/25/2013				Separation		2.0	0.13	0.00			
OH493-2		9/26/2011	3/25/2013				Separation		2.3	0.13	0.00			
OH493-2		9/26/2011	3/25/2013				Separation		2.5	0.50	0.19	W	6.3	0.13
OH493-2		9/26/2011	3/25/2013				Separation		5.1	0.13	0.00			
OH493-2		9/26/2011	3/25/2013	5	0	5.4	Separation	0.9	5.4	3.00	1.25	W	41.7	0.84
OH493-2		9/26/2011	3/25/2013				Separation		5.9	0.13	0.00			
OH493-2		9/26/2011	3/25/2013				Separation		6.1	2.00	0.19	W	6.3	0.13
OH493-2		9/26/2011	3/25/2013				Separation		6.5	0.25	0.06	W	2.1	0.04
OH493-2		9/26/2011	3/25/2013				Separation		7.9	1.25	0.00			
OH493-2		9/26/2011	3/25/2013				BOH		20.4	0.00	0.00			

¹ Number of fractures (FR) in immediate roof beam

² Number of fracture zones (FZ) in immediate roof beam

³ Fracture Density = (FR + 2 FZ)/Beam Height

Table 7-1
Observation Borehole Fractures and Offset Data Summary

Hole	Location	Initial Inspection Date	Recent Inspection Date	FR ¹	FZ ²	Beam Height (ft)	Feature	Fracture Density ³	Feature Depth (ft)	Separation (in)	Offset (ft)	Compass	Hole Closure (%)	Offset Rate (in/yr)
OH605-2	E140-S3394	9/26/2011	9/7/2012				Separation		1.4	1.00	0.19	E	6.3	0.20
OH605-2		9/26/2011	9/7/2012				Separation		2.1	0.13	0.00			
OH605-2		9/26/2011	9/7/2012				Separation		5.2	4.00	0.13	E	4.2	0.13
OH605-2		9/26/2011	9/7/2012				Separation		6.2	2.25	0.00			
OH605-2		9/26/2011	9/7/2012	4	0	6.5	Separation	0.6	6.5	2.00	2.00	E	66.7	2.10
OH605-2		9/26/2011	9/7/2012				Separation		6.7	0.25	0.00			
OH605-2		9/26/2011	9/7/2012				BOH		20.2	0.00	0.00			
OH606-2	E140-S3480	9/26/2011	9/7/2012				Separation		0.4	0.25	0.00			
OH606-2		9/26/2011	9/7/2012				Separation		1.6	0.06	0.00			
OH606-2		9/26/2011	9/7/2012	2	0	4.3	Separation	0.5	4.3	1.50	2.00	W	66.7	2.10
OH606-2		9/26/2011	9/7/2012				Separation		5.3	1.25	0.00			
OH606-2		9/26/2011	9/7/2012				Separation		5.7	0.13	0.00			
OH606-2		9/26/2011	9/7/2012				Separation		7.7	1.25	0.00			
OH606-2		9/26/2011	9/7/2012				BOH		20.2	0.00	0.00			
OH571-1	E140-S3527	9/26/2011	6/3/2013	0	0	4.9	Separation	0.0	4.9	0.50	1.00	W	33.3	0.59
OH571-1		9/26/2011	6/3/2013				Separation		5.1	0.13	0.00			
OH571-1		9/26/2011	6/3/2013				Separation		5.2	0.50	0.13	W	4.2	0.07
OH571-1		9/26/2011	6/3/2013				Separation		7.2	0.13	0.00			
OH571-1		9/26/2011	6/3/2013				BOH		20.4	0.00	0.00			

¹ Number of fractures (FR) in immediate roof beam

² Number of fracture zones (FZ) in immediate roof beam

³ Fracture Density = (FR + 2 FZ)/Beam Height

Table 7-1
Observation Borehole Fractures and Offset Data Summary

Hole	Location	Initial Inspection Date	Recent Inspection Date	FR ¹	FZ ²	Beam Height (ft)	Feature	Fracture Density ³	Feature Depth (ft)	Separation (in)	Offset (ft)	Compass	Hole Closure (%)	Offset Rate (in/yr)
OH607-1	E140-S3580	9/26/2011	6/3/2013				Separation		0.9	0.13	0.00			
OH607-1		9/26/2011	6/3/2013				Separation		4.8	0.13	0.00			
OH607-1		9/26/2011	6/3/2013				Separation		4.9	0.38	0.06	W	2.1	0.04
OH607-1		9/26/2011	6/3/2013	3	0	5.2	Separation	0.6	5.2	0.25	0.13	W	4.2	0.07
OH607-1		9/26/2011	6/3/2013				Separation		5.6	0.13	0.00			
OH607-1		9/26/2011	6/3/2013				Separation		7.2	2.25	0.06	W	2.1	0.04
OH607-1		9/26/2011	6/3/2013				BOH		20.3	0.00	0.06	W	2.1	0.04
OH567-1	E140-S3650	9/26/2011	6/3/2013	0	0	4.7	Separation	0.0	4.7	0.13	0.75	N	25.0	0.44
OH567-1		9/26/2011	6/3/2013				Separation		5.2	0.13	0.00			
OH567-1		9/26/2011	6/3/2013				Separation		6.8	0.13	0.13	N	4.2	0.07
OH567-1		9/26/2011	6/3/2013				Separation		8.1	0.13	0.00			
OH567-1		9/26/2011	6/3/2013				BOH		20.2	0.00	0.00			
OH901-2	W395-S2832	5/15/2012	12/17/2012				Separation		1.0	0.13	0.00			
OH901-2		5/15/2012	12/17/2012				Separation		1.7	1.00	0.00			
OH901-2		5/15/2012	12/17/2012				Separation		4.2	1.25	0.00			
OH901-2		5/15/2012	12/17/2012				Separation		4.7	1.00	0.00			
OH901-2		5/15/2012	12/17/2012	4	0	5.3	Separation	0.8	5.3	3.00	2.00	W	66.7	3.38
OH901-2		5/15/2012	12/17/2012				Separation		7.9	4.00	0.00			
OH901-2		5/15/2012	12/17/2012				BOH		20.4	0.00	0.00			

¹ Number of fractures (FR) in immediate roof beam

² Number of fracture zones (FZ) in immediate roof beam

³ Fracture Density = (FR + 2 FZ)/Beam Height

Table 7-1
Observation Borehole Fractures and Offset Data Summary

Hole	Location	Initial Inspection Date	Recent Inspection Date	FR ¹	FZ ²	Beam Height (ft)	Feature	Fracture Density ³	Feature Depth (ft)	Separation (in)	Offset (ft)	Compass	Hole Closure (%)	Offset Rate (in/yr)
OH902-2	W393-S2912	5/15/2012	12/17/2012				Separation		1.2	1.00	0.13	E	4.2	0.21
OH902-2		5/15/2012	12/17/2012				Separation		2.1	0.25	0.00			
OH902-2		5/15/2012	12/17/2012	2	0	5.6	Separation	0.4	5.6	1.50	0.38	E	12.5	0.63
OH902-2		5/15/2012	12/17/2012				Separation		5.9	0.38	0.00			
OH902-2		5/15/2012	12/17/2012				Separation		6.0	5.00	1.50	E	50.0	2.53
OH902-2		5/15/2012	12/17/2012				BOH		20.2	0.00	0.00			
OH903-2	W393-S2994	5/15/2012	12/17/2012				Separation		0.6	0.25	0.13	E	4.2	0.21
OH903-2		5/15/2012	12/17/2012				Separation		5.3	2.50	0.13	E	4.2	0.21
OH903-2		5/15/2012	12/17/2012	2	0	5.7	Separation	0.4	5.7	3.00	0.50	E	16.7	0.84
OH903-2		5/15/2012	12/17/2012				BOH		20.2	0.00	0.00			
OH922-1	W2759-S2750	2/6/2011	12/17/2012				Separation		1.1	0.75	0.00			
OH922-1		2/6/2011	12/17/2012				Separation		4.4	2.50	0.00			
OH922-1		2/6/2011	12/17/2012				Separation		4.9	0.38	0.00			
OH922-1		2/6/2011	12/17/2012	3	0	5.6	Separation	0.5	5.6	1.50	2.25	N	75.0	1.21
OH922-1		2/6/2011	12/17/2012				BOH		20.4	0.00	0.00			
OH923-1	S2750-W461	2/6/2011	12/17/2012				Separation		1.2	0.13	0.00			
OH923-1		2/6/2011	12/17/2012				Separation		2.7	0.38	0.00			
OH923-1		2/6/2011	12/17/2012				Separation		3.6	0.13	0.00			
OH923-1		2/6/2011	12/17/2012				Separation		4.7	0.13	0.00			
OH923-1		2/6/2011	12/17/2012	4	0	5.7	Separation	0.7	5.7	7.00	3.00	S	100.0	1.61

¹ Number of fractures (FR) in immediate roof beam

² Number of fracture zones (FZ) in immediate roof beam

³ Fracture Density = (FR + 2 FZ)/Beam Height

Table 7-1
Observation Borehole Fractures and Offset Data Summary

Hole	Location	Initial Inspection Date	Recent Inspection Date	FR ¹	FZ ²	Beam Height (ft)	Feature	Fracture Density ³	Feature Depth (ft)	Separation (in)	Offset (ft)	Compass	Hole Closure (%)	Offset Rate (in/yr)
OH935-1	S3080-W395	2/7/2011	1/21/2013				Separation		3.7	0.06	0.00			
OH935-1		2/7/2011	1/21/2013				Separation		4.9	0.13	0.00			
OH935-1		2/7/2011	1/21/2013				Separation		5.3	0.38	0.13	W	4.2	0.06
OH935-1		2/7/2011	1/21/2013	3	0	5.7	Separation	0.5	5.7	5.00	0.50	NW	16.7	0.26
OH935-1		2/7/2011	1/21/2013				BOH		20.1	0.00	0.00			
OH935-1		2/7/2011	1/21/2013				Hangup		15.5	0.00	0.00			
OH936-1	S3080-W463	2/7/2011	4/8/2013				Separation		1.2	1.00	0.50	S	16.7	0.23
OH936-1		2/7/2011	4/8/2013				Separation		1.3	0.13	0.00			
OH936-1		2/7/2011	4/8/2013				Separation		2.0	1.00	0.00			
OH936-1		2/7/2011	4/8/2013				Separation		4.8	0.13	0.00			
OH936-1		2/7/2011	4/8/2013	4	0	5.3	Separation	0.8	5.3	1.50	2.25	S	75.0	1.04
OH936-1		2/7/2011	4/8/2013				Separation		5.5	6.00	0.00			
OH936-1		2/7/2011	4/8/2013				Hangup		6.2	0.00	0.00			
OH936-1		2/7/2011	4/8/2013				BOH		20.4	0.00	0.00			
OH937-1	S3080-W529	2/7/2011	9/10/2012				Separation		1.2	0.13	0.06	S	2.1	0.04
OH937-1		2/7/2011	9/10/2012				Separation		4.8	0.13	0.00			
OH937-1		2/7/2011	9/10/2012	2	0	5.5	Separation	0.4	5.5	5.00	1.00	N	33.3	0.63
OH937-1		2/7/2011	9/10/2012				Separation		6.2	0.75	0.00			
OH937-1		2/7/2011	9/10/2012				BOH		20.3	0.00	0.00			

¹ Number of fractures (FR) in immediate roof beam

² Number of fracture zones (FZ) in immediate roof beam

³ Fracture Density = (FR + 2 FZ)/Beam Height

Table 7-1
Observation Borehole Fractures and Offset Data Summary

Hole	Location	Initial Inspection Date	Recent Inspection Date	FR ¹	FZ ²	Beam Height (ft)	Feature	Fracture Density ³	Feature Depth (ft)	Separation (in)	Offset (ft)	Compass	Hole Closure (%)	Offset Rate (in/yr)
OH938-1	S3080-W592	2/7/2011	9/10/2012				Separation		1.0	0.13	0.00			
OH938-1		2/7/2011	9/10/2012				Separation		3.3	0.06	0.00			
OH938-1		2/7/2011	9/10/2012				Separation		4.6	0.13	0.00			
OH938-1		2/7/2011	9/10/2012				Separation		4.8	4.50	0.00			
OH938-1		2/7/2011	9/10/2012				Separation		5.2	0.13	0.38	S	12.5	0.24
OH938-1		2/7/2011	9/10/2012	5	0	5.5	Separation	0.9	5.5	2.00	0.19	N	6.3	0.12
OH938-1		2/7/2011	9/10/2012				Separation		6.2	2.50	1.25	N	41.7	0.79
OH938-1		2/7/2011	9/10/2012				BOH		20.3	0.00	0.00			
OH1001	W390-S2268	9/23/2010	1/16/2013	0	0	8.7	Separation	0.0	8.7	0.13	0.38	E	12.5	0.16
OH1001		9/23/2010	1/16/2013				Hangup		13.7	0.00	0.13	E	4.2	0.05
OH1001		9/23/2010	5/21/2013				Separation		2.2	0.13	0.00			
OH1001		9/23/2010	5/21/2013				Separation		14.3	0.00	0.25	E	8.3	0.09
OH1001		9/23/2010	5/21/2013				BOH		20.5	0.00	0.00			
OH1002	W390-S2348	9/23/2010	5/21/2013	0	0	8.1	Rough Spot	0.0	8.1	0.00	0.00			
OH1002		9/23/2010	5/21/2013				BOH		20.6	0.00	0.00			
OH1003	W-390-S2432	9/23/2010	5/21/2013				BOH		20.2	0.00	0.00			
OH1003		9/23/2010	5/21/2013	0	0	7.9	Separation	0.0	7.9	0.13	0.00			

¹ Number of fractures (FR) in immediate roof beam

² Number of fracture zones (FZ) in immediate roof beam

³ Fracture Density = (FR + 2 FZ)/Beam Height

Table 7-1
Observation Borehole Fractures and Offset Data Summary

Hole	Location	Initial Inspection Date	Recent Inspection Date	FR ¹	FZ ²	Beam Height (ft)	Feature	Fracture Density ³	Feature Depth (ft)	Separation (in)	Offset (ft)	Compass	Hole Closure (%)	Offset Rate (in/yr)
OH1004	W520-S2268	9/14/2010	3/25/2013				Separation		1.3	0.13	0.00			
OH1004		9/14/2010	3/25/2013				Separation		3.0	0.13	0.00			
OH1004		9/14/2010	3/25/2013	2	0	7.6	Separation	0.3	7.6	0.13	0.00			
OH1004		9/14/2010	3/25/2013				BOH		20.7	0.00	0.00			
OH1005	W520-S2350	9/14/2010	12/17/2012	0	0	8.7	Separation		8.7	0.13	0.00			
OH1005		9/14/2010	12/17/2012				BOH		20.5	0.00	0.00			
OH1006	W520-S2429	9/14/2010	5/22/2013				Separation		0.4	0.38	0.19	W	6.3	0.07
OH1006		9/14/2010	5/22/2013	1	0	7.4	Separation	0.1	7.4	0.13	0.13	E	4.2	0.05
OH1006		9/14/2010	5/22/2013				Rough Spot		14.1	0.00	0.13	W	4.2	0.05
OH1006		9/14/2010	5/22/2013				BOH		20.2	0.00	0.00			
OH1006		9/14/2010	5/22/2013				Separation		6.1	0.13	0.13	W	4.2	0.05
OH1007	W660-S2267	11/15/2010	5/22/2013	1	0	8.2	Hangup	0.1	8.2	0.00	0.00			
OH1007		11/15/2010	5/22/2013				BOH		20.4	0.00	0.00			
OH1008	W660-S2351	11/15/2010	5/22/2013				Separation		6.2	0.13	0.00			
OH1008		11/15/2010	5/22/2013				Separation		6.8	0.13	0.00			
OH1008		11/15/2010	5/22/2013	2	0	7.0	Separation	0.3	7.0	0.13	0.00			
OH1008		11/15/2010	5/22/2013				BOH		20.5	0.00	0.00			
OH1009	W660-S2433	11/15/2010	5/22/2013				Rough Spot		7.0	0.00	0.00			
OH1009		11/15/2010	5/22/2013	0	0	7.5	Rough Spot	0.0	7.5	0.00	0.00			
OH1009		11/15/2010	5/22/2013				BOH		20.4	0.00	0.00			

¹ Number of fractures (FR) in immediate roof beam

² Number of fracture zones (FZ) in immediate roof beam

³ Fracture Density = (FR + 2 FZ)/Beam Height

Table 7-1
Observation Borehole Fractures and Offset Data Summary

Hole	Location	Initial Inspection Date	Recent Inspection Date	FR ¹	FZ ²	Beam Height (ft)	Feature	Fracture Density ³	Feature Depth (ft)	Separation (in)	Offset (ft)	Compass	Hole Closure (%)	Offset Rate (in/yr)
OH1010	W790-S2265	11/15/2010	5/22/2013	0	0	8.0	Hangup	0.0	8.0	0.00	1.25	E	41.7	0.50
OH1010		11/15/2010	5/22/2013				Hangup		13.9	0.00	0.00			
OH1010		11/15/2010	5/22/2013				BOH		20.6	0.00	0.00			
OH1011	W790-S2349	11/15/2010	5/22/2013				Separation		6.2	0.13	0.25	E	8.3	0.10
OH1011		11/15/2010	5/22/2013	1	0	7.6	Hangup	0.1	7.6	0.00	0.38	E	12.5	0.15
OH1011		11/15/2010	5/22/2013				BOH		20.6	0.00	0.00			
OH1012	W790-S2430	12/21/2011	5/22/2013	0	0	7.5	Separation	0.0	6.8	0.13	1.25	E	41.7	0.88
OH1012		12/21/2011	5/22/2013				Separation		6.5	0.13	0.00			
OH1012		12/21/2011	5/22/2013				BOH		20.6	0.00	0.00			
OH1013	W920-S2231	3/1/2011	5/22/2013	1	0	7.2	Rough Spot	0.1	7.2	0.13	0.25	E	8.3	0.11
OH1013		3/1/2011	5/22/2013				BOH		20.5	0.00	0.00			
OH1014	W920-S2350	3/1/2011	5/22/2013				Separation		7.2	0.13	0.25	E	8.3	0.11
OH1014		3/1/2011	5/22/2013	1	0	7.8	Separation	0.1	7.8	0.13	0.50	E	16.7	0.22
OH1014		3/1/2011	5/22/2013				BOH		20.5	0.00	0.00			
OH1015	W920-S2465	3/1/2011	5/22/2013				Separation		6.8	0.13	0.00			
OH1015		3/1/2011	5/22/2013	1	0	7.2	Separation	0.1	7.2	0.13	0.00			
OH1015		3/1/2011	5/22/2013				BOH		20.5	0.00	0.00			
OH1016	W1050-S2269	3/1/2011	5/21/2013	0	0	7.7	Separation	0.0	7.7	0.25	0.19	E	6.3	0.08
OH1016		3/1/2011	5/21/2013				BOH		20.3	0.00	0.00			

¹ Number of fractures (FR) in immediate roof beam

² Number of fracture zones (FZ) in immediate roof beam

³ Fracture Density = (FR + 2 FZ)/Beam Height

Table 7-1
Observation Borehole Fractures and Offset Data Summary

Hole	Location	Initial Inspection Date	Recent Inspection Date	FR ¹	FZ ²	Beam Height (ft)	Feature	Fracture Density ³	Feature Depth (ft)	Separation (in)	Offset (ft)	Compass	Hole Closure (%)	Offset Rate (in/yr)
OH1017	W1050-S2352	3/1/2011	5/21/2013	0	0	6.8	Rough Spot	0.0	6.8	0.00	0.00			
OH1017		3/1/2011	5/21/2013				BOH		20.2	0.00	0.00			
OH1018	W1050-S2434	3/1/2011	5/21/2013	0	0	6.8	Separation	0.0	6.8	0.13	0.00			
OH1018		3/1/2011	5/21/2013				BOH		20.2	0.00	0.00			
OH1019	W1190-S2267	3/21/2011	5/21/2013				Separation		6.8	0.13	0.00			
OH1019		3/21/2011	5/21/2013				Rough Spot		8.0	0.00	0.00			
OH1019		3/21/2011	5/21/2013	1	0	7.6	Hangup	0.1	7.6	0.00	0.00			
OH1019		3/21/2011	5/21/2013				BOH		20.2	0.00	0.00			
OH1020	W1190-2348	3/21/2011	5/21/2013	0	0	7.7	Separation	0.0	7.7	0.13	0.00			
OH1020		3/21/2011	5/21/2013				Hangup		8.0	0.00	0.25	W	8.3	0.12
OH1020		3/21/2011	5/21/2013				BOH		20.5	0.00	0.00			
OH1021	W1190-2348	3/21/2011	12/11/2012	0	0	7.8	Rough Spot	0.0	7.8	0.00	0.00			
OH1021		3/21/2011	12/11/2012				BOH		20.4	0.00	0.00			
OH1021		3/21/2011	3/25/2013				Separation		6.9	0.13	0.00			
OH1021		3/21/2011	3/25/2013	0	0	7.3	Separation	0.0	7.3	0.13	0.00			
OH1021		3/21/2011	3/25/2013				BOH		20.5	0.00	0.00			
OH1021		3/21/2011	5/21/2013	0	0	7.1	Separation	0.0	7.1	0.13	0.00			
OH1021		3/21/2011	5/21/2013				BOH		20.5	0.00	0.00			

¹ Number of fractures (FR) in immediate roof beam

² Number of fracture zones (FZ) in immediate roof beam

³ Fracture Density = (FR + 2 FZ)/Beam Height

Table 7-1
Observation Borehole Fractures and Offset Data Summary

Hole	Location	Initial Inspection Date	Recent Inspection Date	FR ¹	FZ ²	Beam Height (ft)	Feature	Fracture Density ³	Feature Depth (ft)	Separation (in)	Offset (ft)	Compass	Hole Closure (%)	Offset Rate (in/yr)
OH1022	S2180-W392	9/14/2010	5/21/2013	0	0	8.5	Separation	0.0	8.5	0.13	2.00	S	66.7	0.74
OH1022		9/14/2010	5/21/2013				BOH		20.7	0.00	0.00			
OH1022		9/14/2010	5/21/2013				Hangup		14.7	0.00	1.25	S	41.7	0.47
OH1023	S2180-W460	9/14/2010	5/21/2013	0	0	7.8	Separation	0.0	7.8	0.13	1.00	N	33.3	0.37
OH1023		9/14/2010	5/21/2013				BOH		20.6	0.00	0.00			
OH1023		9/14/2010	5/21/2013				Separation		14.8	0.13	0.38	N	12.5	0.14
OH1024	S2180-W522	9/14/2010	5/21/2013				Separation		0.5	0.13	0.19	S	6.3	0.07
OH1024		9/14/2010	5/21/2013	1	0	8.6	Separation	0.1	8.6	0.13	1.00	S	33.3	0.37
OH1024		9/14/2010	5/21/2013				Hangup		14.8	0.00	1.25	S	41.7	0.47
OH1024		9/14/2010	5/21/2013				BOH		20.4	0.00	0.00			
OH1025	S2180-W593	9/14/2010	5/21/2013	0	0	8.8	Hangup	0.0	8.8	0.00	0.38	N	12.5	0.14
OH1025		9/14/2010	5/21/2013				BOH		20.4	0.00	0.00			

¹ Number of fractures (FR) in immediate roof beam

² Number of fracture zones (FZ) in immediate roof beam

³ Fracture Density = (FR + 2 FZ)/Beam Height

Table 7-1
Observation Borehole Fractures and Offset Data Summary

Hole	Location	Initial Inspection Date	Recent Inspection Date	FR ¹	FZ ²	Beam Height (ft)	Feature	Fracture Density ³	Feature Depth (ft)	Separation (in)	Offset (ft)	Compass	Hole Closure (%)	Offset Rate (in/yr)
OH1026	S2180-W662	9/14/2010	5/21/2013	0	0	8.2	Separation	0.0	8.2	0.13	1.75	S	58.3	0.65
OH1026		9/14/2010	5/21/2013				Separation		14.4	0.13	1.25	S	41.7	0.47
OH1026		9/14/2010	5/21/2013				Rough Spot		20.4	0.00	0.00			
OH1026		9/14/2010	5/21/2013				Separation		0.5	0.06	0.06	SW	2.1	0.02
OH1027	S2180-W727	9/14/2010	3/14/2013				Separation		6.6	0.13	0.00			
OH1027		9/14/2010	3/14/2013				Separation		7.7	0.13	0.00			
OH1027		9/14/2010	3/14/2013	3	0	8.0	Separation	0.4	8.0	0.13	2.00	N	66.7	0.80
OH1027		9/14/2010	3/14/2013				Hangup		14.2	0.00	0.00			
OH1027		9/14/2010	3/14/2013				BOH		20.6	0.00	0.00			
OH1027		9/14/2010	5/21/2013				Separation		8.1	0.13	2.50	S	83.3	0.93
OH1028	S2180-W793	9/14/2010	5/21/2013				Separation		2.2	0.13	0.06	S	2.1	0.02
OH1028		9/14/2010	5/21/2013				Separation		8.0	0.13	0.38	S	12.5	0.14
OH1028		9/14/2010	5/21/2013	2	0	8.2	Separation	0.2	8.2	0.13	0.50	S	16.7	0.19
OH1028		9/14/2010	5/21/2013				Separation		14.6	0.00	1.00	S	33.3	0.37
OH1028		9/14/2010	5/21/2013				BOH		20.2	0.00	0.00			
OH1029	S2180-W861	9/14/2010	5/21/2013				Rough Spot		6.3					
OH1029		9/14/2010	5/21/2013	0	0	8.3	BOH	0.0	8.3	0.13	3.00	N	100.0	1.12

¹ Number of fractures (FR) in immediate roof beam

² Number of fracture zones (FZ) in immediate roof beam

³ Fracture Density = (FR + 2 FZ)/Beam Height

Table 7-1
Observation Borehole Fractures and Offset Data Summary

Hole	Location	Initial Inspection Date	Recent Inspection Date	FR ¹	FZ ²	Beam Height (ft)	Feature	Fracture Density ³	Feature Depth (ft)	Separation (in)	Offset (ft)	Compass	Hole Closure (%)	Offset Rate (in/yr)
OH1030	S2180-W928	9/14/2010	5/21/2013				Separation		8.1	0.13	0.00			
OH1030		9/14/2010	5/21/2013	1	0	8.4	Separation	0.1	8.4	0.13	2.00	S	66.7	0.74
OH1030		9/14/2010	5/21/2013				Hangup		14.7	0.00	1.00	S	33.3	0.37
OH1030		9/14/2010	5/21/2013				BOH		20.3	0.00	0.00			
OH1031	S2180-W985	9/14/2010	5/21/2013				Separation		7.4	0.13	0.13	N	4.2	0.05
OH1031		9/14/2010	5/21/2013	1	0	7.7	Separation	0.1	7.7	0.13	0.38	N	12.5	0.14
OH1031		9/14/2010	5/21/2013				BOH		20.7	0.00	0.00			
OH1031		9/14/2010	5/21/2013				Hangup		14.6	0.00	0.00			
OH1032	S2180-W1058	9/14/2010	5/21/2013				Separation		6.6	0.13	0.00			
OH1032		9/14/2010	5/21/2013				Separation		6.7	0.13	0.00			
OH1032		9/14/2010	5/21/2013				Separation		7.3	0.13	0.00			
OH1032		9/14/2010	5/21/2013	3	0	7.4	Separation	0.4	7.4	0.13	2.00	S	66.7	0.74
OH1032		9/14/2010	5/21/2013				Hangup		13.9	0.00	0.00			
OH1032		9/14/2010	5/21/2013				BOH		20.9	0.00	0.00			
OH1033	S2180-W1127	3/1/2011	5/21/2013				Separation		5.9	0.13	0.00			
OH1033		3/1/2011	5/21/2013	1	0	7.5	Separation	0.1	6.3	0.13	2.00	S	66.7	0.90
OH1033		3/1/2011	5/21/2013				BOH		20.6	0.00	0.00			
OH1034	S2180-W1193	3/21/2011	5/21/2013	0	0	7.1	Separation	0.0	7.1	0.13	2.00	SE	66.7	0.92
OH1034		3/21/2011	5/21/2013				Hangup		13.3	0.00	0.00			
OH1034		3/21/2011	5/21/2013				BOH		20.2	0.00	0.00			

¹ Number of fractures (FR) in immediate roof beam

² Number of fracture zones (FZ) in immediate roof beam

³ Fracture Density = (FR + 2 FZ)/Beam Height

Table 7-1
Observation Borehole Fractures and Offset Data Summary

Hole	Location	Initial Inspection Date	Recent Inspection Date	FR ¹	FZ ²	Beam Height (ft)	Feature	Fracture Density ³	Feature Depth (ft)	Separation (in)	Offset (ft)	Compass	Hole Closure (%)	Offset Rate (in/yr)
OH1035	S2180-W393	9/10/2010	5/21/2013	0	0	7.9	Separation	0.0	7.9	0.13	1.75	N	58.3	0.65
OH1035		9/10/2010	5/21/2013				Hangup		13.8	0.00	1.50	N	50.0	0.56
OH1035		9/10/2010	5/21/2013				BOH		20.4	0.00	0.00			
OH1036	S2180-W466	9/10/2010	5/21/2013				Separation		5.9	0.13	0.00			
OH1036		9/10/2010	5/21/2013				Separation		6.1	0.13	0.00			
OH1036		9/10/2010	5/21/2013	2	0	7.4	Separation	0.3	7.4	0.13	0.00			
OH1036		9/10/2010	5/21/2013				Hangup		13.7	0.00	0.00			
OH1036		9/10/2010	5/21/2013				BOH		19.7	0.00	0.00			
OH1037	S2180-W524	11/15/2010	5/21/2013				Separation		6.6	0.13	1.75	N	58.3	0.70
OH1037		11/15/2010	5/21/2013	1	0	7.9	Separation	0.1	7.9	0.13	1.50	N	50.0	0.60
OH1037		11/15/2010	5/21/2013				Hangup		14.0	0.00	0.00			
OH1037		11/15/2010	5/21/2013				BOH		20.6	0.00	0.00			
OH1038	S2180-W594	11/15/2010	5/21/2013	0	0	8.1	Hangup	0.0	8.1	0.00	0.00			
OH1038		11/15/2010	5/21/2013				BOH		21.9	0.00	0.00			
OH1039	S2180-W659	11/15/2010	5/21/2013	0	0	7.6	Separation	0.0	7.6	0.13	1.25	N	41.7	0.50
OH1039		11/15/2010	5/21/2013				Separation		13.7	0.13	1.00	N	33.3	0.40
OH1039		11/15/2010	5/21/2013				BOH		20.4	0.00	0.00			

¹ Number of fractures (FR) in immediate roof beam

² Number of fracture zones (FZ) in immediate roof beam

³ Fracture Density = (FR + 2 FZ)/Beam Height

Table 7-1
Observation Borehole Fractures and Offset Data Summary

Hole	Location	Initial Inspection Date	Recent Inspection Date	FR ¹	FZ ²	Beam Height (ft)	Feature	Fracture Density ³	Feature Depth (ft)	Separation (in)	Offset (ft)	Compass	Hole Closure (%)	Offset Rate (in/yr)
OH1040	S2180-W726	11/15/2010	5/21/2013				Separation		6.7	0.13	0.00			
OH1040		11/15/2010	5/21/2013				Separation		6.6	0.13	0.00			
OH1040		11/15/2010	5/21/2013	2	0	7.4	Separation	0.3	7.4	0.13	0.00			
OH1040		11/15/2010	5/21/2013				Separation		13.8	0.13	0.00			
OH1040		11/15/2010	5/21/2013				BOH		20.6	0.00	0.00			
OH1040		11/15/2010	5/21/2013				Separation		2.2	0.25	0.25	N	8.3	0.10
OH1040		11/15/2010	5/21/2013	1	0	7.9	Separation	0.1	7.9	0.13	2.50	N	83.3	0.99
OH1041	S2180-W794	11/15/2010	3/11/2013				Separation		2.1	0.13	0.19	N	6.3	0.08
OH1041		11/15/2010	3/11/2013	1	0	8.0	Separation	0.1	8.0	0.13	2.25	N	75.0	0.97
OH1041		11/15/2010	3/11/2013				Hangup		14.3	0.00	1.00	N	33.3	0.43
OH1041		11/15/2010	3/11/2013				BOH		20.4	0.00	0.00			
OH1042	S2180-W860	11/15/2010	5/21/2013				Separation		6.7	0.13	0.00			
OH1042		11/15/2010	5/21/2013				Rough Spot		6.3	0.00	0.00			
OH1042		11/15/2010	5/21/2013	1	0	7.0	Separation	0.1	7.0	0.13	1.50	N	50.0	0.60
OH1042		11/15/2010	5/21/2013				BOH		20.5	0.00	0.00			
OH1043	S2180-W923	3/1/2011	5/21/2013				Separation		4.2	0.13	0.00			
OH1043		3/1/2011	5/21/2013	1	0	8.0	Separation	0.1	8.0	0.13	2.75	N	91.7	1.24
OH1044	S2180-W993	3/1/2011	5/21/2013	0	0	7.3	Separation	0.0	7.3	0.13	0.13	N	4.2	0.06
OH1044		3/1/2011	5/21/2013				Separation		7.5	0.13	0.00			
OH1044		3/1/2011	5/21/2013				BOH		20.5	0.00	0.00			

¹ Number of fractures (FR) in immediate roof beam

² Number of fracture zones (FZ) in immediate roof beam

³ Fracture Density = (FR + 2 FZ)/Beam Height

Table 7-1
Observation Borehole Fractures and Offset Data Summary

Hole	Location	Initial Inspection Date	Recent Inspection Date	FR ¹	FZ ²	Beam Height (ft)	Feature	Fracture Density ³	Feature Depth (ft)	Separation (in)	Offset (ft)	Compass	Hole Closure (%)	Offset Rate (in/yr)
OH1045	S2180-W1056	3/1/2011	3/11/2013	0	0	7.5	Separation	0.0	7.5	0.13	2.50	N	83.3	1.23
OH1045		3/1/2011	3/11/2013				BOH		20.4	0.00	0.00			
OH1046	S2180-W1123	3/21/2013	5/21/2013	0	0	7.6	Hangup	0.0	7.6	0.00	0.06	N	2.1	0.37
OH1046		3/21/2013	5/21/2013				Rough Spot		7.1	0.00	0.00			
OH1046		3/21/2013	5/21/2013				BOH		20.5	0.00	0.00			
OH1047	S2180-W1192	3/21/2013	5/21/2013	0	0	7.4	Separation	0.0	7.4	0.13	2.00	NE	66.7	11.97
OH1047		3/21/2013	5/21/2013				Hangup		13.6	0.00	0.00			
OH1047		3/21/2013	5/21/2013				BOH		20.4	0.00	0.00			
OH860	E0-N1266	3/8/2009	6/4/2013				Separation		1.6	1.00	0.13	W	4.2	0.03
OH860		3/8/2009	6/4/2013				Separation		3.1	2.75	0.13	W	4.2	0.03
OH860		3/8/2009	6/4/2013	2	0	5.9	Separation	0.3	5.9	0.13	0.13	W	4.2	0.03
OH860		3/8/2009	6/4/2013				Separation		6.1	0.13	0.00			
OH860		3/8/2009	6/4/2013				Separation		6.9	0.13	0.00			
OH860		3/8/2009	6/4/2013				Separation		7.1	0.13	0.00			
OH860		3/8/2009	6/4/2013				Separation		7.3	0.13	0.13	W	4.2	0.03
OH860		3/8/2009	6/4/2013				BOH		20.4	0.00	0.00			

¹ Number of fractures (FR) in immediate roof beam

² Number of fracture zones (FZ) in immediate roof beam

³ Fracture Density = (FR + 2 FZ)/Beam Height

Table 7-1
Observation Borehole Fractures and Offset Data Summary

Hole	Location	Initial Inspection Date	Recent Inspection Date	FR ¹	FZ ²	Beam Height (ft)	Feature	Fracture Density ³	Feature Depth (ft)	Separation (in)	Offset (ft)	Compass	Hole Closure (%)	Offset Rate (in/yr)
OH488	E0-N1100	1/7/2004	6/4/2013				Separation		1.3	0.50	0.06	S	2.1	0.01
OH488		1/7/2004	6/4/2013				Separation		5.1	0.13	0.13	W	4.2	0.01
OH488		1/7/2004	6/4/2013	2	0	6.1	Separation	0.5	6.1	1.25	0.13	W	4.2	0.01
OH488		1/7/2004	6/4/2013				Separation		20.4	0.00	0.00			
OH859	E0-N920	3/8/2009	6/4/2013				Separation		1.1	0.13	0.00			
OH859		3/8/2009	6/4/2013				Separation		2.6	0.13	0.00			
OH859		3/8/2009	6/4/2013				Separation		6.1	0.13	0.00			
OH859		3/8/2009	6/4/2013	3	0	6.5	Separation	0.5	6.5	0.13	0.00			
OH859		3/8/2009	6/4/2013				BOH		20.4	0.00	0.00			
OH490	E0-N780	1/9/2004	11/27/2012				Separation		2.1	0.38	0.00			
OH490		1/9/2004	11/27/2012	1	0	6.2	Separation	0.2	6.2	0.13	0.00			
OH490		1/9/2004	11/27/2012				BOH		6.8	0.13	3.00	E	100.0	0.34
OH491-1	E0-N620	5/18/2012	6/4/2013				Separation		1.0	0.13	0.00			
OH491-1		5/18/2012	6/4/2013				Separation		1.5	1.25	0.00			
OH491-1		5/18/2012	6/4/2013				Separation		2.6	0.50	0.06	W	2.1	0.06
OH491-1		5/18/2012	6/4/2013	3	0	6.6	Hangup	0.5	6.6	0.00	0.06	W	2.1	0.06
OH491-1		5/18/2012	6/4/2013				BOH		20.0	0.00	0.00			
OH888	W30-S700	3/8/2009	6/3/2013	0	0	8.5	Separation	0.0	8.5	0.13	0.13	W	4.2	0.03
OH888		3/8/2009	6/3/2013				BOH		20.3	0.00	0.00			

¹ Number of fractures (FR) in immediate roof beam

² Number of fracture zones (FZ) in immediate roof beam

³ Fracture Density = (FR + 2 FZ)/Beam Height

Table 7-1
Observation Borehole Fractures and Offset Data Summary

Hole	Location	Initial Inspection Date	Recent Inspection Date	FR ¹	FZ ²	Beam Height (ft)	Feature	Fracture Density ³	Feature Depth (ft)	Separation (in)	Offset (ft)	Compass	Hole Closure (%)	Offset Rate (in/yr)
OH887	W30-S850	3/10/2009	6/3/2013				Rough Spot		1.2	0.00	0.00			
OH887		3/10/2009	6/3/2013	0	0	8.6	Hangup	0.0	8.6	0.00	0.38	W	12.5	0.09
OH887		3/10/2009	6/3/2013				BOH		20.2	0.00	0.00			
OH886	W30-S1000	3/3/2009	6/3/2013	0	0	8.8	Separation	0.0	8.8	0.38	0.50	SW	16.7	0.12
OH886		3/3/2009	6/3/2013				Hangup		16.0	0.00	0.50	SW	16.7	0.12
OH886		3/3/2009	6/3/2013				BOH		20.2	0.00	0.00			
OH885	W30-S1150	3/3/2009	6/10/2013				Separation		0.5	0.50	0.06	W	2.1	0.01
OH885		3/3/2009	6/10/2013				Separation		0.8	0.13	0.38	W	12.5	0.09
OH885		3/3/2009	6/10/2013				Separation		1.0	0.13	0.38	W	12.5	0.09
OH885		3/3/2009	6/10/2013				Separation		2.1	0.38	0.19	W	6.3	0.04
OH885		3/3/2009	6/10/2013				Separation		2.5	0.13	0.13	W	4.2	0.03
OH885		3/3/2009	6/10/2013				Separation		2.3	0.13	0.00			
OH885		3/3/2009	6/10/2013	6	0	6.2	Separation	1.0	6.2	0.13	1.00	W	33.3	0.23
OH885		3/3/2009	6/10/2013				Separation		6.7	0.13	0.25	W	8.3	0.06
OH885		3/3/2009	6/10/2013				BOH		20.4	0.00	0.00			
OH884	W30-S1300	3/3/2009	5/22/2013				Separation		0.8	0.13	0.00			
OH884		3/3/2009	5/22/2013	1	0	8.3	Hangup	0.1	8.3	0.00	0.00			
OH884		3/3/2009	5/22/2013				BOH		20.2	0.00	0.00			
OH883	W30-S1485	3/3/2009	5/22/2013	0	0	8.8	Rough Spot	0.0	8.8	0.00	0.00			
OH883		3/3/2009	5/22/2013				BOH		20.2	0.00	0.00			

¹ Number of fractures (FR) in immediate roof beam

² Number of fracture zones (FZ) in immediate roof beam

³ Fracture Density = (FR + 2 FZ)/Beam Height

Table 7-1
Observation Borehole Fractures and Offset Data Summary

Hole	Location	Initial Inspection Date	Recent Inspection Date	FR ¹	FZ ²	Beam Height (ft)	Feature	Fracture Density ³	Feature Depth (ft)	Separation (in)	Offset (ft)	Compass	Hole Closure (%)	Offset Rate (in/yr)
OH882	W30-S1600	3/3/2009	5/22/2013				Separation		0.4	0.13	0.00			
OH882		3/3/2009	5/22/2013	1	0	8.3	Separation	0.1	8.3	0.13	0.13	E	4.2	0.03
OH882		3/3/2009	5/22/2013				BOH		20.1	0.00	0.00			
OH881	W30-S1780	3/3/2009	5/22/2013	0	0	8.3	Rough Spot	0.0	8.3	0.00	0.00			
OH881		3/3/2009	5/22/2013				BOH		20.2	0.00	0.00			
OH880	W30-S1950	3/3/2009	5/22/2013	0	0	8.0	Rough Spot	0.0	8.0	0.00	0.00			
OH880		3/3/2009	5/22/2013				BOH		20.2	0.00	0.00			
OH879	W30-S2060	3/3/2009	5/22/2013				BOH		20.2	0.00	0.00			
OH877	W30-S2350	3/3/2009	6/10/2013				Separation		0.7	0.13	0.00			
OH877		3/3/2009	6/10/2013	1	0	8.0	Hangup	0.1	8.0	0.00	0.13	E	4.2	0.03
OH877		3/3/2009	6/10/2013				BOH		20.3	0.00	0.00			
OH876	W30-S2520	3/3/2009	6/10/2013				Separation		0.7	0.38	0.00			
OH876		3/3/2009	6/10/2013				Separation		6.1	0.13	0.13	S	4.2	0.03
OH876		3/3/2009	6/10/2013	2	0	7.0	Separation	0.3	7.0	0.13	0.13	S	4.2	0.03
OH876		3/3/2009	6/10/2013				Separation		7.6	0.13	0.13	W	4.2	0.03
OH876		3/3/2009	6/10/2013				BOH		18.0	0.00	0.00			
OH876		3/3/2009	6/10/2013				Separation		6.2	0.13	0.00			

¹ Number of fractures (FR) in immediate roof beam

² Number of fracture zones (FZ) in immediate roof beam

³ Fracture Density = (FR + 2 FZ)/Beam Height

Table 7-1
Observation Borehole Fractures and Offset Data Summary

Hole	Location	Initial Inspection Date	Recent Inspection Date	FR ¹	FZ ²	Beam Height (ft)	Feature	Fracture Density ³	Feature Depth (ft)	Separation (in)	Offset (ft)	Compass	Hole Closure (%)	Offset Rate (in/yr)
OH875	W30-S2750	3/3/2009	6/10/2013				Separation		5.4	0.13	0.00			
OH875		3/3/2009	6/10/2013				Separation		5.8	0.13	0.00			
OH875		3/3/2009	6/10/2013				Separation		6.1	0.13	0.00			
OH875		3/3/2009	6/10/2013				Separation		6.6	0.25	0.38	W	12.5	0.09
OH875		3/3/2009	6/10/2013	4	0	7.5	Separation	0.5	7.5	0.13	0.25	E	8.3	0.06
OH875		3/3/2009	6/10/2013				BOH		20.4	0.00	0.00			
OH899	W170-S1000	3/24/2009	5/22/2013	0	0	9.2	Hangup	0.0	9.2	0.00	1.00	E	33.3	0.24
OH899		3/24/2009	5/22/2013				Hangup		15.9	0.00	0.19	E	6.3	0.05
OH899		3/24/2009	5/22/2013				BOH		20.1	0.00	0.00			
OH899		3/24/2009	12/3/2012	0	0	9.2	Separation	0.0	9.2	0.13	0.00			
OH899		3/24/2009	12/3/2012				BOH		20.1	0.00	0.00			
OH897	W170-S1300	3/24/2009	5/22/2013				Rough Spot		7.9	0.00	0.00			
OH897		3/24/2009	5/22/2013	0	0	8.6	Hangup	0.0	8.6	0.00	0.75	E	25.0	0.18
OH897		3/24/2009	5/22/2013				BOH		20.2	0.00	0.00			
OH896	W170-S1482	3/24/2009	5/22/2013	0	0	8.3	Separation	0.0	8.3	0.25	0.13	W	4.2	0.03
OH896		3/24/2009	5/22/2013				Separation		15.0	0.00	0.00			
OH896		3/24/2009	5/22/2013				Separation		17.3	0.00	0.00			
OH895	W170-S1600	3/24/2009	5/22/2013	0	0	8.7	Separation	0.0	8.7	0.25	0.50	E	16.7	0.12
OH895		3/24/2009	5/22/2013				Hangup		15.1	0.00	0.13	E	4.2	0.03
OH895		3/24/2009	5/22/2013				BOH		20.2	0.00	0.00			

¹ Number of fractures (FR) in immediate roof beam

² Number of fracture zones (FZ) in immediate roof beam

³ Fracture Density = (FR + 2 FZ)/Beam Height

Table 7-1
Observation Borehole Fractures and Offset Data Summary

Hole	Location	Initial Inspection Date	Recent Inspection Date	FR ¹	FZ ²	Beam Height (ft)	Feature	Fracture Density ³	Feature Depth (ft)	Separation (in)	Offset (ft)	Compass	Hole Closure (%)	Offset Rate (in/yr)
OH894	W170-S1780	3/24/2009	5/22/2013	0	0	9.6	Separation	0.0	9.6	0.13	0.19	E	6.3	0.05
OH894		3/24/2009	5/22/2013				Rough Spot		15.7	0.00	0.00			
OH894		3/24/2009	5/22/2013				BOH		20.2	0.00	0.00			
OH893	W170-S1950	3/24/2009	5/22/2013	0	0	8.4	Separation	0.0	8.4	0.13	0.25	E	8.3	0.06
OH893		3/24/2009	5/22/2013				BOH		20.1	0.00	0.00			
OH892	W170-S2055	3/24/2009	5/22/2013				Separation		1.1	0.13	0.00			
OH892		3/24/2009	5/22/2013	0	0	7.9	Rough Spot	0.0	7.9	0.00	0.00			
OH892		3/24/2009	5/22/2013				BOH		19.7	0.00	0.00			
OH891	W170-S2180	3/24/2009	5/22/2013	0	0	7.7	Separation	0.0	7.7	0.13	0.25	E	8.3	0.06
OH891		3/24/2009	5/22/2013				BOH		20.2	0.00	0.00			
OH890		3/11/2009	6/10/2013				Separation		4.3	0.13	0.00			
OH890	W170-S2345	3/11/2009	6/10/2013				Rough Spot		5.1	0.00	0.00			
OH890		3/11/2009	6/10/2013				Separation		5.2	0.13	0.00			
OH890		3/11/2009	6/10/2013	1	0	6.8	Separation	0.1	6.8	0.13	0.00			
OH890		3/11/2009	6/10/2013				Hangup		14.3	0.00	0.19	E	6.3	0.04
OH890		3/11/2009	6/10/2013				BOH		20.3	0.00	0.00			
OH890		3/11/2009	6/10/2013				Hangup		8.0	0.00	1.00	E	33.3	0.24
OH889	W170-S1150	3/11/2009	6/10/2013	0	0	8.2	Separation	0.0	8.2	0.25	0.00			
OH889		3/11/2009	6/10/2013				BOH		20.2	0.00	0.00			
OH855	S90-W380	3/4/2009	6/4/2013				BOH		20.1	0.00	0.00			

¹ Number of fractures (FR) in immediate roof beam

² Number of fracture zones (FZ) in immediate roof beam

³ Fracture Density = (FR + 2 FZ)/Beam Height

Table 7-1
Observation Borehole Fractures and Offset Data Summary

Hole	Location	Initial Inspection Date	Recent Inspection Date	FR ¹	FZ ²	Beam Height (ft)	Feature	Fracture Density ³	Feature Depth (ft)	Separation (in)	Offset (ft)	Compass	Hole Closure (%)	Offset Rate (in/yr)
OH856	S90-W620	3/4/2009	6/4/2013				Separation		1.1	0.13	0.00			
OH856		3/4/2009	6/4/2013				Separation		1.2	0.13	0.00			
OH856		3/4/2009	6/4/2013	2	0	9.0	Separation	0.2	9.0	0.00	0.13	W	4.2	0.03
OH856		3/4/2009	6/4/2013				BOH		20.2	0.00	0.00			
OH857	S90-W880	3/4/2009	6/11/2013	0	0	6.5	Rough Spot	0.0	6.5	0.00	0.00			
OH857		3/4/2009	6/11/2013				BOH		20.4	0.00	0.00			
OH850	N300-W80	3/8/2009	6/11/2013				Separation		4.7	0.13	0.00			
OH850		3/8/2009	6/11/2013				Separation		5.4	0.13	0.00			
OH850		3/8/2009	6/11/2013				Separation		5.7	0.13	0.00			
OH850		3/8/2009	6/11/2013				Rough Spot		6.6	0.00	0.00			
OH850		3/8/2009	6/11/2013				Separation		7.1	0.13	0.00			
OH850		3/8/2009	6/11/2013				BOH		20.2	0.00	0.00			
OH850		3/8/2009	6/11/2013	4	0	8.2	Separation	0.5	8.2	0.13	2.00	S	66.7	0.47
OH858	W469-N216	3/8/2009	6/11/2013				Separation		5.6	0.13	0.00			
OH858		3/8/2009	6/11/2013				Separation		6.2	0.13	0.00			
OH858		3/8/2009	6/11/2013				Separation		8.0	0.13	0.00			
OH858		3/8/2009	6/11/2013	3	0	8.4	Separation	0.4	8.4	0.13	0.13	S	4.2	0.03
OH858		3/8/2009	6/11/2013				Separation		9.1	0.13	0.19	S	6.3	0.04
OH858		3/8/2009	6/11/2013				BOH		20.1	0.00	0.00			

¹ Number of fractures (FR) in immediate roof beam

² Number of fracture zones (FZ) in immediate roof beam

³ Fracture Density = (FR + 2 FZ)/Beam Height

Table 7-1
Observation Borehole Fractures and Offset Data Summary

Hole	Location	Initial Inspection Date	Recent Inspection Date	FR ¹	FZ ²	Beam Height (ft)	Feature	Fracture Density ³	Feature Depth (ft)	Separation (in)	Offset (ft)	Compass	Hole Closure (%)	Offset Rate (in/yr)
OH852	N785-E195	3/8/2009	11/28/2012				Separation		6.2	0.13	0.00			
OH852		3/8/2009	11/28/2012				Separation		6.3	0.13	0.00			
OH852		3/8/2009	11/28/2012				Separation		6.4	0.13	0.00			
OH852		3/8/2009	11/28/2012				Separation		6.5	0.13	0.00			
OH852		3/8/2009	11/28/2012	4	0	7.1	Separation	0.6	7.1	0.13	3.00	S	100.0	0.80
OH869	E300-S1430	3/24/2009	6/10/2013				Separation		0.4	0.13	0.00			
OH869		3/24/2009	6/10/2013	1	0	8.1	Rough Spot	0.1	8.1	0.00	0.00			
OH869		3/24/2009	6/10/2013				Rough Spot		6.6	0.00	0.00			
OH869		3/24/2009	6/10/2013				BOH		20.2	0.00	0.00			
OH868	E300-S1780	3/24/2009	6/10/2013	0	0	8.8	Hangup	0.0	8.8	0.00	0.00			
OH868		3/24/2009	6/10/2013				BOH		20.2	0.00	0.00			
OH867	E300-S2060	3/24/2009	6/10/2013	0	0	8.7	Rough Spot	0.0	8.7	0.00	0.00			
OH867		3/24/2009	6/10/2013				BOH		20.1	0.00	0.00			
OH864	S1600-E227	3/24/2009	6/10/2013	0	0	7.8	Separation	0.0	7.8	0.13	0.00			
OH864		3/24/2009	6/10/2013				BOH		20.2	0.00	0.00			

¹ Number of fractures (FR) in immediate roof beam

² Number of fracture zones (FZ) in immediate roof beam

³ Fracture Density = (FR + 2 FZ)/Beam Height

Table 7-1
Observation Borehole Fractures and Offset Data Summary

Hole	Location	Initial Inspection Date	Recent Inspection Date	FR ¹	FZ ²	Beam Height (ft)	Feature	Fracture Density ³	Feature Depth (ft)	Separation (in)	Offset (ft)	Compass	Hole Closure (%)	Offset Rate (in/yr)
OH445-1	W170-S3080	6/12/2012	1/21/2013				Separation		0.6	0.13	0.25	S	8.3	0.41
OH445-1		6/12/2012	1/21/2013				Separation		1.1	1.50	0.25	E	8.3	0.41
OH445-1		6/12/2012	1/21/2013				Separation		5.2	0.13	0.00			
OH445-1		6/12/2012	1/21/2013				Separation		5.6	0.13	0.00			
OH445-1		6/12/2012	1/21/2013	5	0	5.8	Separation	0.9	5.8	0.13	0.50	E	16.7	0.82
OH445-1		6/12/2012	1/21/2013				Hangup		6.2	0.00	0.00			
OH445-1		6/12/2012	1/21/2013				BOH		22.1	0.00	0.00			
OH457	E300-S3260	8/1/2003	6/17/2013				Separation		1.3	0.50	0.25	E	8.3	0.03
OH457		8/1/2003	6/17/2013				Separation		3.1	0.13	0.00			
OH457		8/1/2003	6/17/2013	2	0	5.5	Separation	0.4	5.5	0.25	0.00			
OH457		8/1/2003	6/17/2013				Hangup		6.1	0.00	0.19	W	6.3	0.02
OH457		8/1/2003	6/17/2013				BOH		21.1	0.00	0.00			
OH457		8/1/2003	6/17/2013				Separation		0.8	0.13	0.00			
OH458	E300-S3295	8/1/2003	6/16/2013				Separation		1.6	0.75	0.38	E	12.5	0.04
OH458		8/1/2003	6/16/2013				Separation		5.9	0.13	0.00			
OH458		8/1/2003	6/16/2013	2	0	6.2	Separation	0.3	6.2	0.13	0.00			
OH458		8/1/2003	6/16/2013				BOH		20.7	0.00	0.00			

¹ Number of fractures (FR) in immediate roof beam

² Number of fracture zones (FZ) in immediate roof beam

³ Fracture Density = (FR + 2 FZ)/Beam Height

Table 7-1
Observation Borehole Fractures and Offset Data Summary

Hole	Location	Initial Inspection Date	Recent Inspection Date	FR ¹	FZ ²	Beam Height (ft)	Feature	Fracture Density ³	Feature Depth (ft)	Separation (in)	Offset (ft)	Compass	Hole Closure (%)	Offset Rate (in/yr)
OH459	E300-3140	8/1/2003	6/17/2013				Separation		1.0	0.13	0.00			
OH459		8/1/2003	6/17/2013				Separation		1.5	1.25	0.00			
OH459		8/1/2003	6/17/2013				Separation		4.3	0.13	0.00			
OH459		8/1/2003	6/17/2013	3	0	5.6	Separation	0.5	5.6	0.13	0.00			
OH459		8/1/2003	6/17/2013				Hangup		5.9	0.00	0.00			
OH459		8/1/2003	6/17/2013				BOH		20.7	0.00	0.00			
OH453	E300-S3310	8/15/2003	6/11/2013				Separation		6.2	0.13	0.00			
OH453		8/15/2003	6/11/2013	1	0	6.5	Separation	0.2	6.5	0.13	0.00			
OH453		8/15/2003	6/11/2013				Hangup		7.8	0.00	0.00			
OH453		8/15/2003	6/11/2013				BOH		21.0	0.00	0.00			
OH622	E300-S3400	6/15/2006	6/11/2013				Separation		1.2	0.25	0.75	E	25.0	0.11
OH622		6/15/2006	6/11/2013				Separation		4.3	0.13	0.00			
OH622		6/15/2006	6/11/2013				Hangup		4.9	0.00	0.00			
OH622		6/15/2006	6/11/2013	2	0	5.6	Separation	0.4	5.6	0.38	0.38	E	12.5	0.05
OH622		6/15/2006	6/11/2013				BOH		20.8	0.00	0.00			
OH623	E300-S3450	6/15/2006	6/11/2013				Hangup		4.8	0.00	0.00			
OH623		6/15/2006	6/11/2013	0	0	5.8	Separation	0.0	5.8	0.13	0.13	E	4.2	0.02
OH623		6/15/2006	6/11/2013				BOH		20.8	0.00	0.00			

¹ Number of fractures (FR) in immediate roof beam

² Number of fracture zones (FZ) in immediate roof beam

³ Fracture Density = (FR + 2 FZ)/Beam Height

Table 7-1
Observation Borehole Fractures and Offset Data Summary

Hole	Location	Initial Inspection Date	Recent Inspection Date	FR ¹	FZ ²	Beam Height (ft)	Feature	Fracture Density ³	Feature Depth (ft)	Separation (in)	Offset (ft)	Compass	Hole Closure (%)	Offset Rate (in/yr)
OH624	E300-S3550	6/15/2006	6/11/2013				Separation		5.1	0.06	0.00			
OH624		6/15/2006	6/11/2013	1	0	6.2	Separation	0.2	6.2	0.13	0.00			
OH624		6/15/2006	6/11/2013				BOH		16.6	0.00	0.00			
OH573	S3650-W170	4/27/2005	1/8/2013				Hangup		5.3	0.00	0.00			
OH573		4/27/2005	1/8/2013	0	0	5.5	Separation	0.0	5.5	0.13	0.00			
OH573		4/27/2005	1/8/2013				Separation		50.0	0.00	0.00			
OH564	S3650-W90	4/20/2005	1/8/2013				Separation		1.4	1.00	1.75	S	58.3	0.23
OH564		4/20/2005	1/8/2013				Separation		2.3	5.00	0.00			
OH564		4/20/2005	1/8/2013				Separation		5.7	0.13	0.00			
OH564		4/20/2005	1/8/2013	3	0	6.2	Separation	0.5	6.2	0.13	1.50	N	50.0	0.19
OH564		4/20/2005	1/8/2013				Hangup		16.5	0.00	0.00			
OH564		4/20/2005	1/8/2013				BOH		21.4	0.00	0.00			
OH565	S3650-W30	2/19/2005	6/3/2013				Separation		1.5	0.13	0.00			
OH565		2/19/2005	6/3/2013				Separation		5.2	0.13	0.00			
OH565		2/19/2005	6/3/2013	2	0	5.7	Separation	0.4	5.7	0.13	2.25	S	75.0	0.27
OH565		2/19/2005	6/3/2013				Separation		5.9	0.13	0.00			
OH565		2/19/2005	6/3/2013				Hangup		16.3	0.00	0.00			
OH565		2/19/2005	6/3/2013				BOH		20.9	0.00	0.00			

¹ Number of fractures (FR) in immediate roof beam

² Number of fracture zones (FZ) in immediate roof beam

³ Fracture Density = (FR + 2 FZ)/Beam Height

Table 7-1
Observation Borehole Fractures and Offset Data Summary

Hole	Location	Initial Inspection Date	Recent Inspection Date	FR ¹	FZ ²	Beam Height (ft)	Feature	Fracture Density ³	Feature Depth (ft)	Separation (in)	Offset (ft)	Compass	Hole Closure (%)	Offset Rate (in/yr)
OH566	S3650-E50	4/20/2005	6/3/2013				Separation		1.5	0.13	0.00			
OH566		4/20/2005	6/3/2013				Separation		2.7	1.50	0.00			
OH566		4/20/2005	6/3/2013				Hangup		5.0	0.00	0.00			
OH566		4/20/2005	6/3/2013	2	0	5.3	Separation	0.4	5.3	0.13	0.25	S	8.3	0.03
OH566		4/20/2005	6/3/2013				Hangup		5.4	0.00	0.00			
OH566		4/20/2005	6/3/2013				Separation		5.9	0.13	0.00			
OH566		4/20/2005	6/3/2013				Separation		6.6	0.13	0.00			
OH566		4/20/2005	6/3/2013				BOH		21.2	0.00	0.00			
OH567-1	S3650-E140	9/26/2011	6/3/2013	0	0	4.7	Separation	0.0	4.7	0.13	0.75	N	25.0	0.44
OH567-1		9/26/2011	6/3/2013				Separation		5.2	0.13	0.00			
OH567-1		9/26/2011	6/3/2013				Separation		6.8	0.13	0.13	N	4.2	0.07
OH567-1		9/26/2011	6/3/2013				Separation		8.1	0.13	0.00			
OH567-1		9/26/2011	6/3/2013				BOH		20.2	0.00	0.00			
OH568	S3650-E235	4/20/2005	6/3/2013				Separation		1.5	0.13	0.00			
OH568		4/20/2005	6/3/2013	1	0	5.9	Separation	0.2	5.9	0.13	0.19	S	6.3	0.02
OH568		4/20/2005	6/3/2013				BOH		20.9	0.00	0.00			
OH569		4/20/2005	6/10/2013	0	0	5.1	Separation	0.0	5.1	0.75	1.00	N	33.3	0.12
OH569	S3650-E300	4/20/2005	6/10/2013				Separation		5.8	0.13	0.00			
OH569		4/20/2005	6/10/2013				BOH		20.8	0.00	0.00			

¹ Number of fractures (FR) in immediate roof beam

² Number of fracture zones (FZ) in immediate roof beam

³ Fracture Density = (FR + 2 FZ)/Beam Height

Table 7-1
Observation Borehole Fractures and Offset Data Summary

Hole	Location	Initial Inspection Date	Recent Inspection Date	FR ¹	FZ ²	Beam Height (ft)	Feature	Fracture Density ³	Feature Depth (ft)	Separation (in)	Offset (ft)	Compass	Hole Closure (%)	Offset Rate (in/yr)
OH503-1	S3080-E230	6/14/2010	1/8/2013				Separation		0.2	0.13	0.00			
OH503-1		6/14/2010	1/8/2013				Separation		1.3	0.50	2.00	S	66.7	0.78
OH503-1		6/14/2010	1/8/2013				Separation		2.3	0.50	1.00	S	33.3	0.39
OH503-1		6/14/2010	1/8/2013				Separation		3.6	2.00	1.00	S	33.3	0.39
OH503-1		6/14/2010	1/8/2013				Separation		4.5	0.25	0.00			
OH503-1		6/14/2010	1/8/2013				Separation		5.5	0.13	0.00			
OH503-1		6/14/2010	1/8/2013	6	0	5.7	Separation	1.1	5.7	0.13	0.00			
OH503-1		6/14/2010	1/8/2013				Separation		5.9	0.13	0.00			
OH503-1		6/14/2010	1/8/2013				BOH		20.4	0.00	0.00			
OH514-1	W30-S3400	3/15/2009	6/10/2013				Separation		0.6	0.50	0.50	E	16.7	0.12
OH514-1		3/15/2009	6/10/2013	1	0	4.9	Separation	0.2	4.9	0.13	0.00			
OH514-1		3/15/2009	6/10/2013				Separation		6.1	0.13	0.00			
OH514-1		3/15/2009	6/10/2013				BOH		20.3	0.00	0.00			
OH608-1	W170-S3580	3/1/2009	1/8/2013				Separation		0.5	0.13	0.00			
OH608-1		3/1/2009	1/8/2013				Separation		1.1	0.13	0.00			
OH608-1		3/1/2009	1/8/2013				Separation		2.1	5.00	0.00			
OH608-1		3/1/2009	1/8/2013	2	0	5.3	Separation	0.4	5.3	0.13	0.00			
OH608-1		3/1/2009	1/8/2013				Separation		6.4	0.13	0.00			
OH608-1		3/1/2009	1/8/2013				BOH		20.7	0.00	0.00			

¹ Number of fractures (FR) in immediate roof beam

² Number of fracture zones (FZ) in immediate roof beam

³ Fracture Density = (FR + 2 FZ)/Beam Height

Table 7-1
Observation Borehole Fractures and Offset Data Summary

Hole	Location	Initial Inspection Date	Recent Inspection Date	FR ¹	FZ ²	Beam Height (ft)	Feature	Fracture Density ³	Feature Depth (ft)	Separation (in)	Offset (ft)	Compass	Hole Closure (%)	Offset Rate (in/yr)
OH609-1	W170-S3485	3/1/2009	1/8/2013				Separation		1.2	0.25	0.00			
OH609-1		3/1/2009	1/8/2013				Separation		2.9	1.00	0.00			
OH609-1		3/1/2009	1/8/2013				Separation		2.1	4.50	0.00			
OH609-1		3/1/2009	1/8/2013				Rough Spot		5.6	0.00	0.00			
OH609-1		3/1/2009	1/8/2013	3	0	6.2	Separation	0.5	6.2	0.25	2.50	E	83.3	0.65
OH610-1	W170-3580	3/1/2009	1/8/2013	0	0	5.7	Separation	0.0	5.7	0.13	0.00			
OH610-1		3/1/2009	1/8/2013				BOH		20.3	0.00	0.00			
OH449	W30-S3310	8/15/2003	6/10/2013				Separation		5.0	0.13	0.00			
OH449		8/15/2003	6/10/2013	1	0	5.8	Separation	0.2	5.8	0.38	0.38	E	12.5	0.04
OH449		8/15/2003	6/10/2013				Separation		6.7	0.13	0.00			
OH449		8/15/2003	6/10/2013				Rough Spot		7.4	0.00	0.00			
OH449		8/15/2003	6/10/2013				Hangup		7.7	0.00	0.00			
OH449		8/15/2003	6/10/2013				BOH		21.6	0.00	0.00			

¹ Number of fractures (FR) in immediate roof beam

² Number of fracture zones (FZ) in immediate roof beam

³ Fracture Density = (FR + 2 FZ)/Beam Height

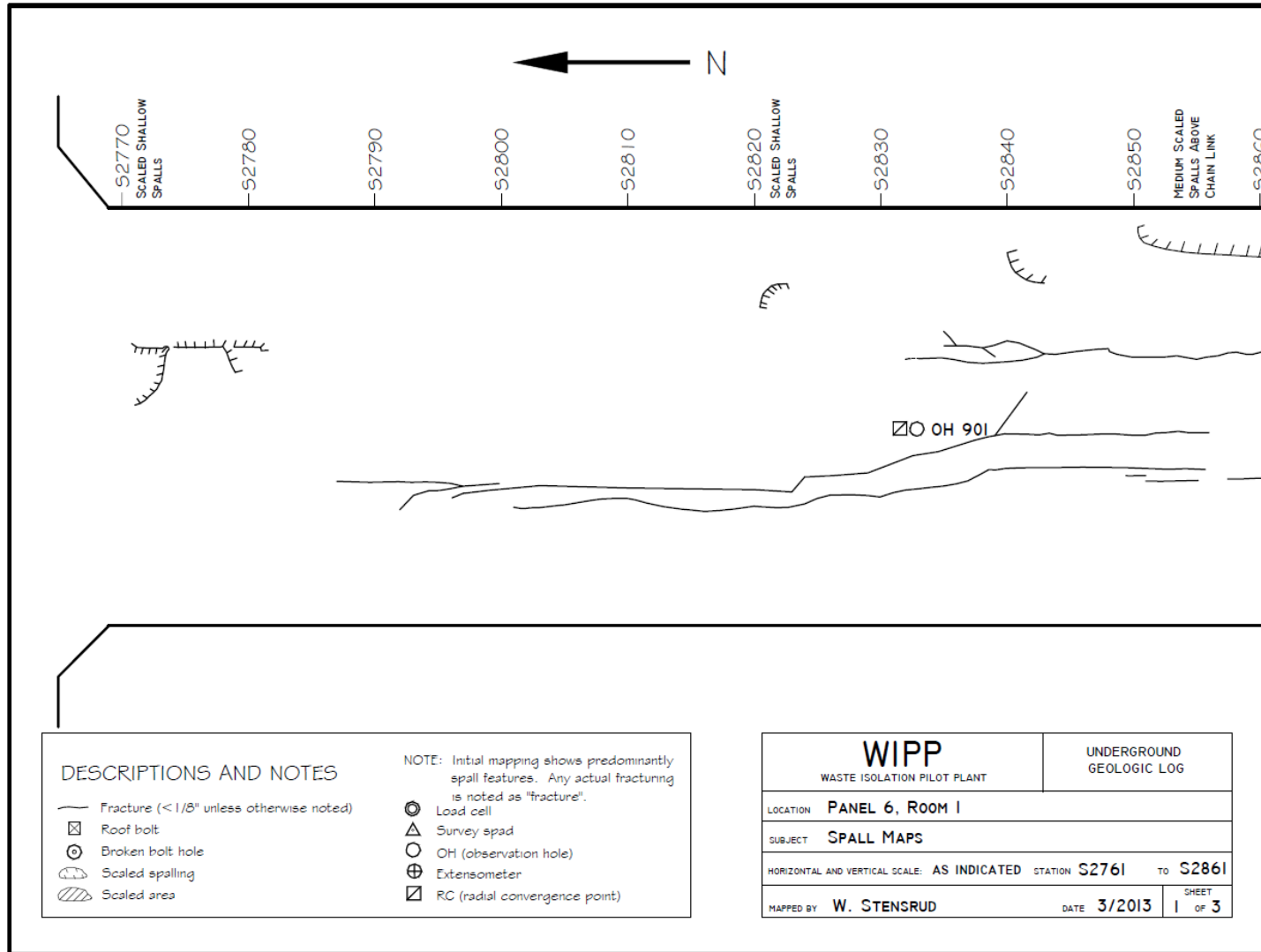

Figure 7-1
Panel 6 Room 1, S2761-S2861 Roof Fractures

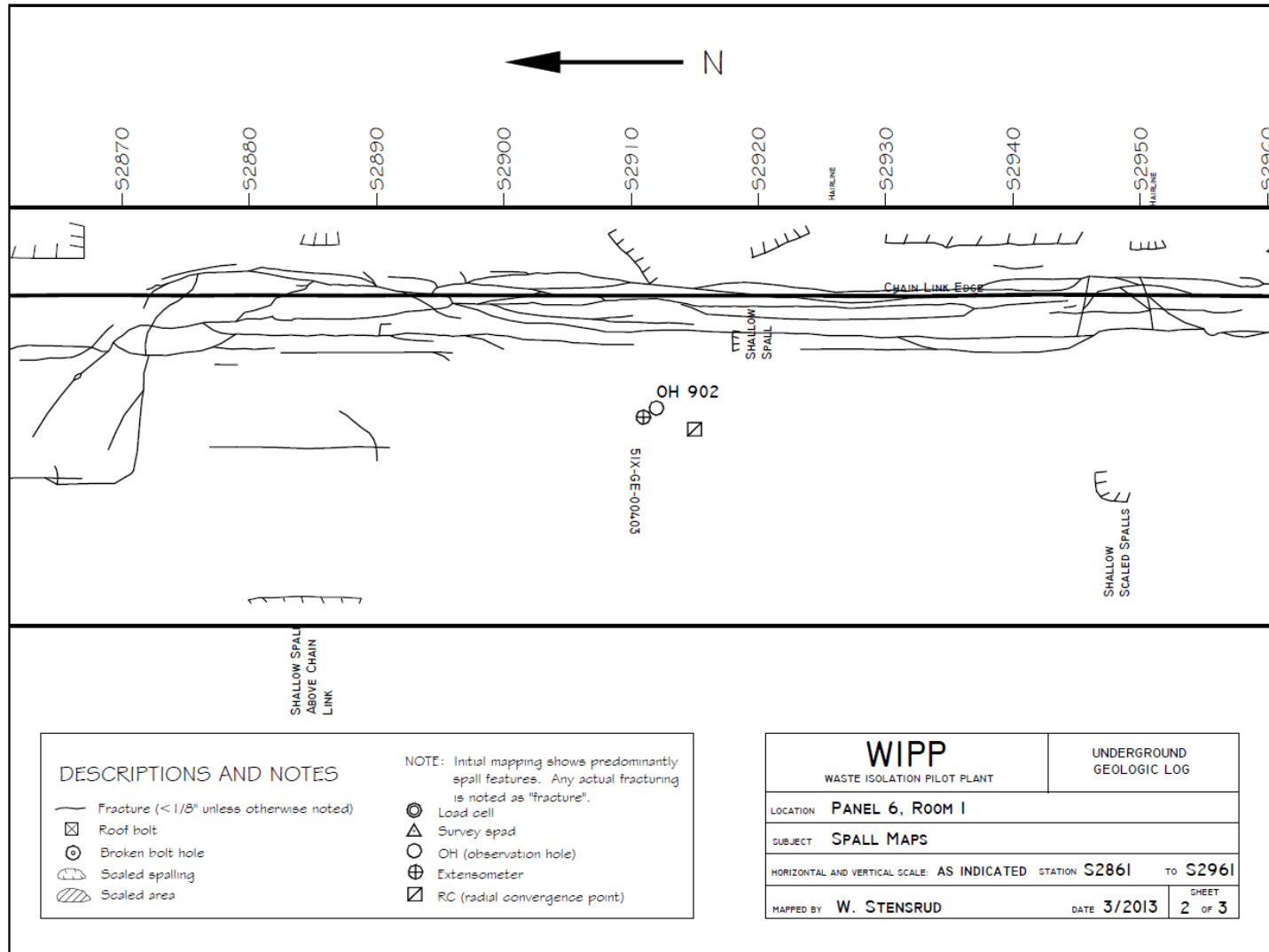

Figure 7-2
Panel 6 Room 1, S2861-S2961 Roof Fractures

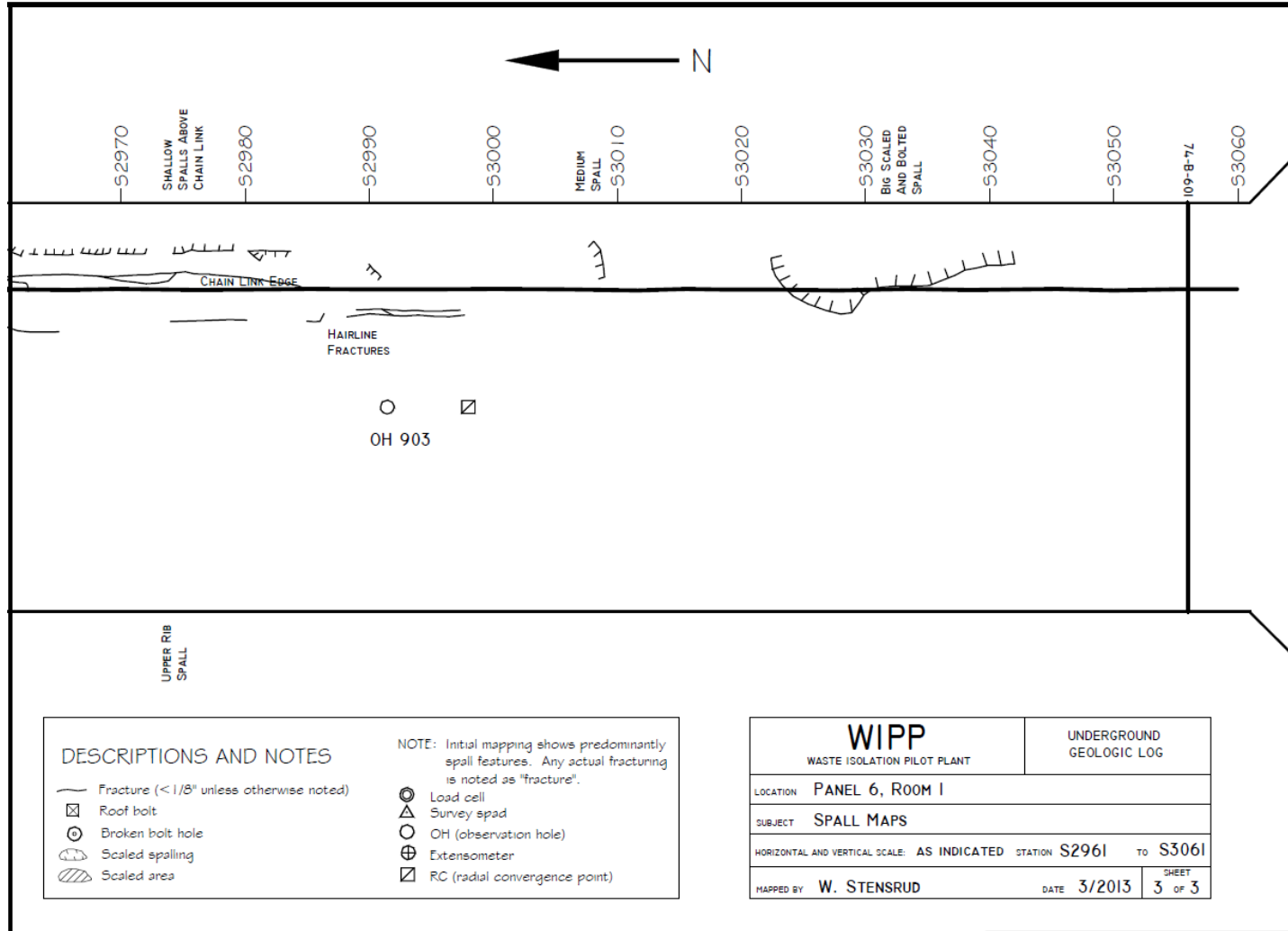

Figure 7-3
Panel 6 Room 1, S2961-S3061 Roof Fractures

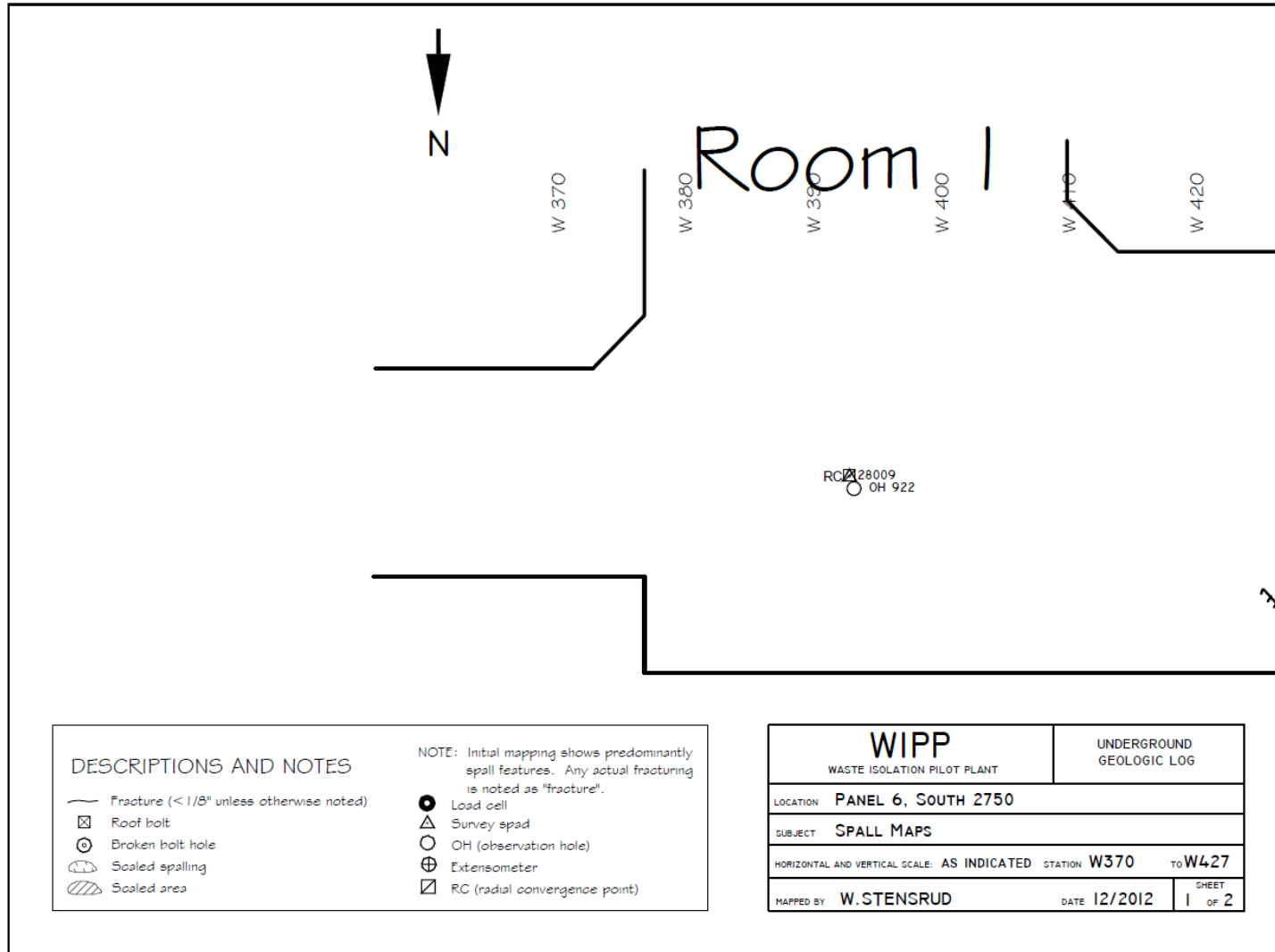

Figure 7-4
Panel 6 South 2750, W370-W427 Roof Fractures

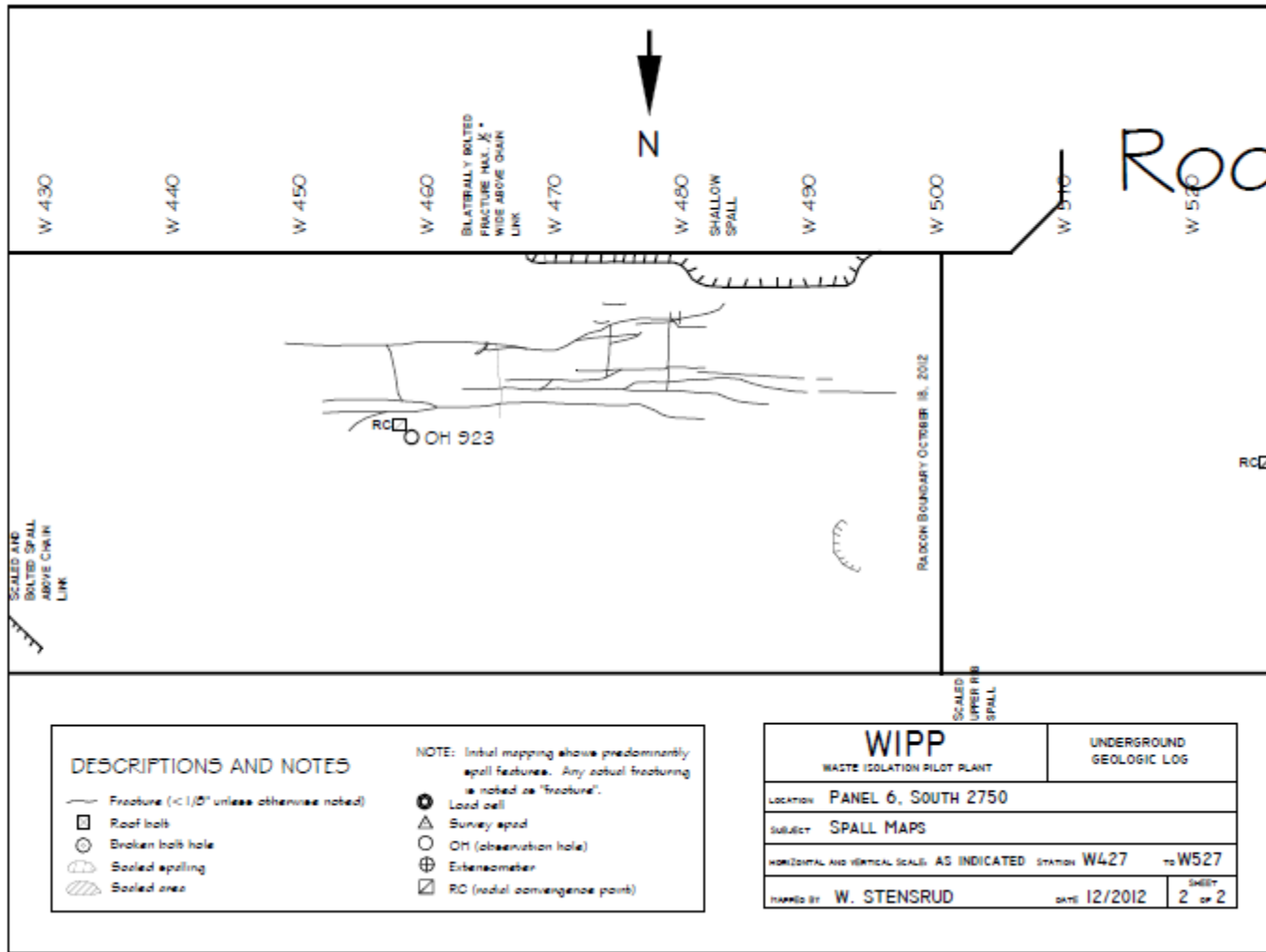

Figure 7-5
Panel 6 South 2750, W427-W527 Roof Fractures

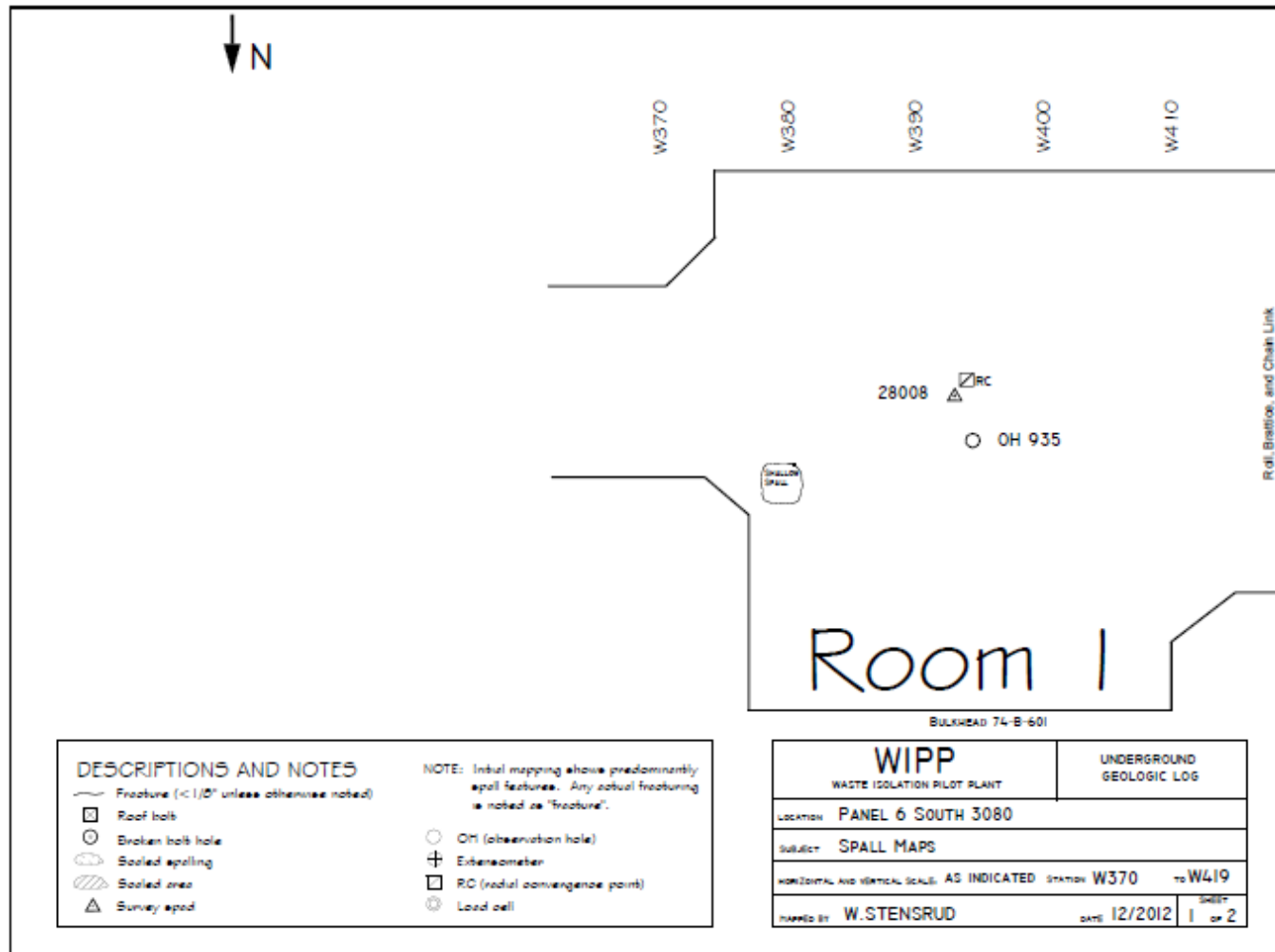

Figure 7-6
 Panel 6 South 3080, W370-W419 Roof Fractures

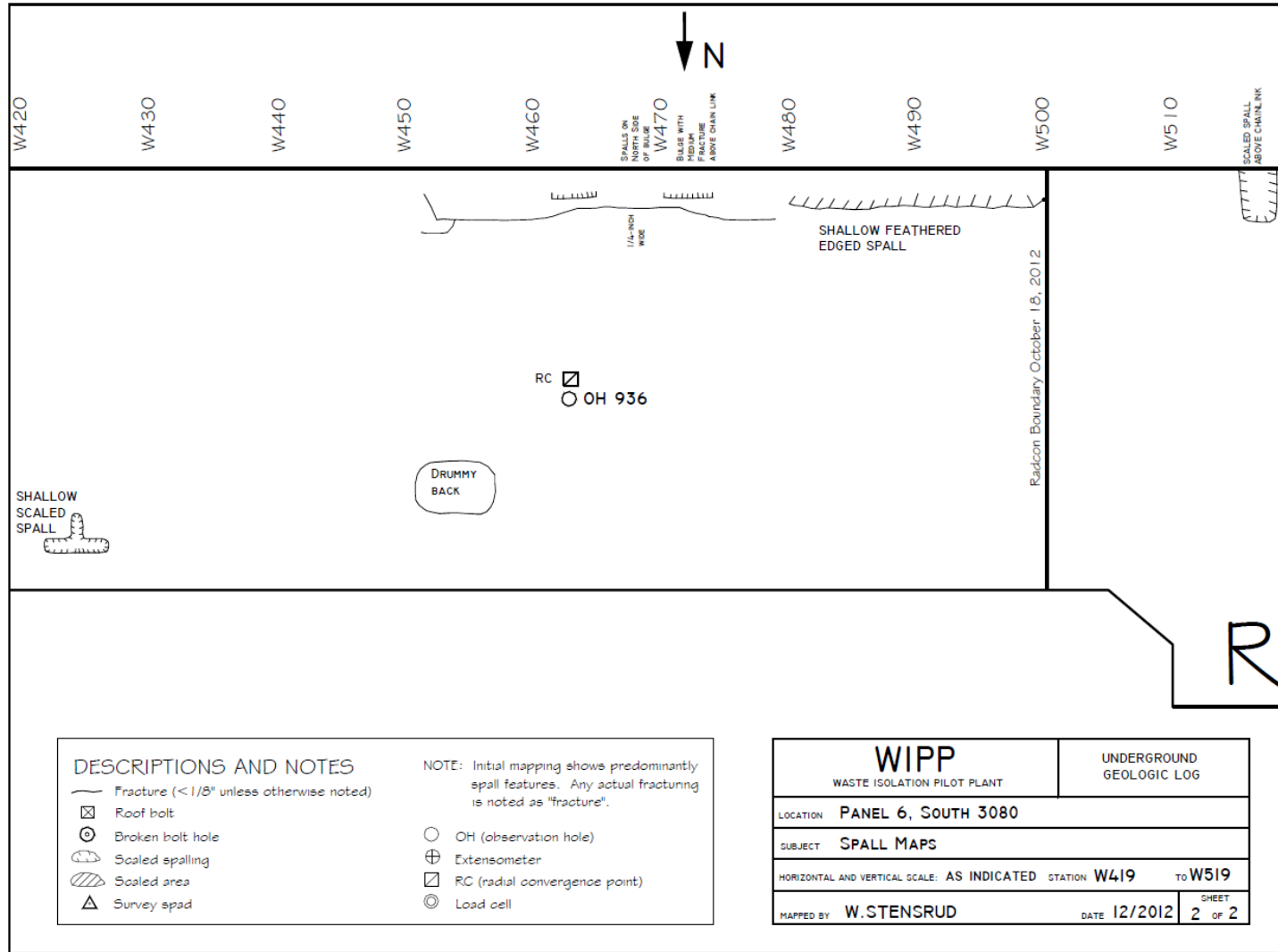

Figure 7-7
Panel 6 South 3080, W419-W519 Roof Fractures

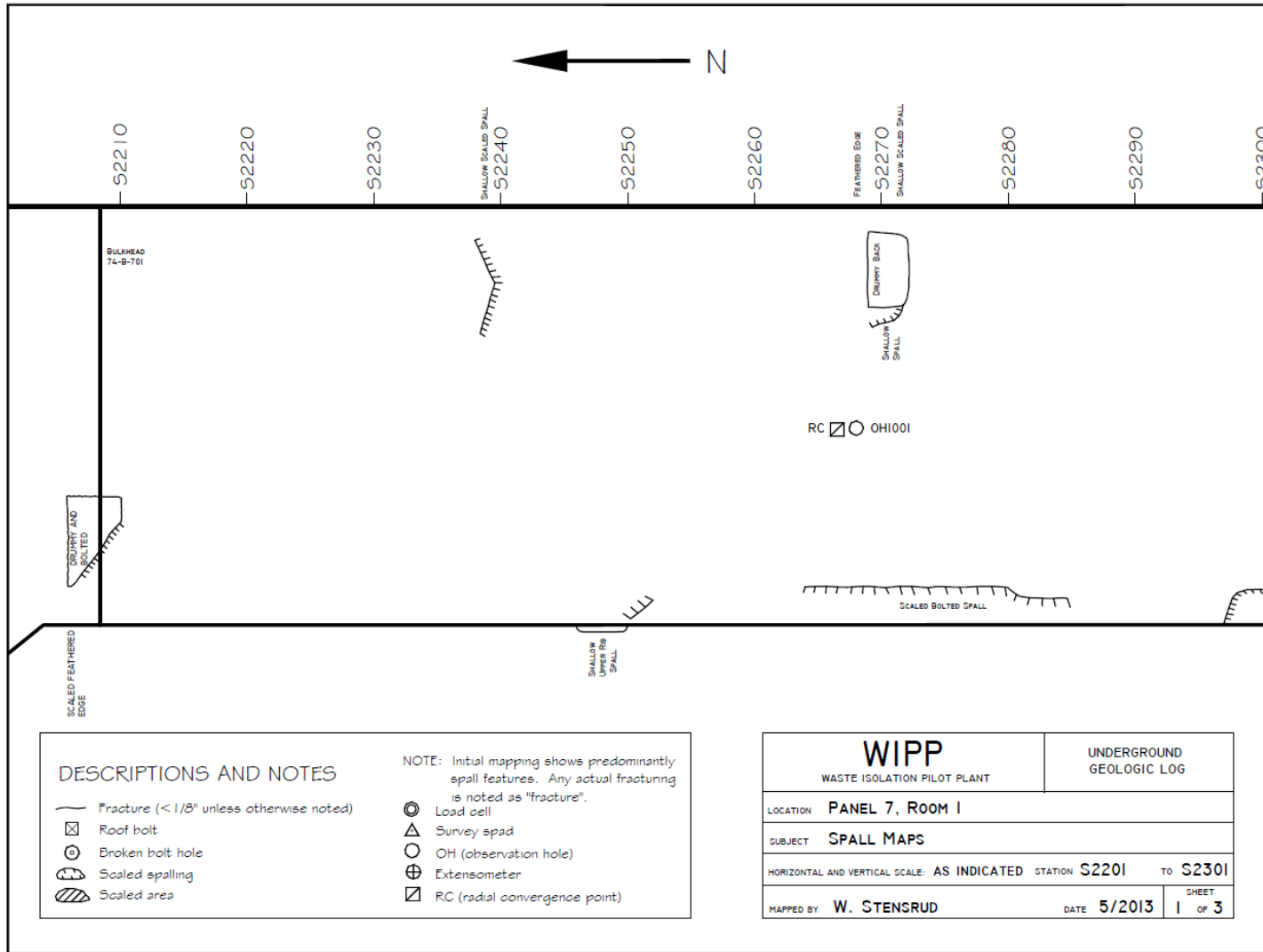

Figure 7-8
Panel 7 Room 1, S2201-S2301 Roof Fractures

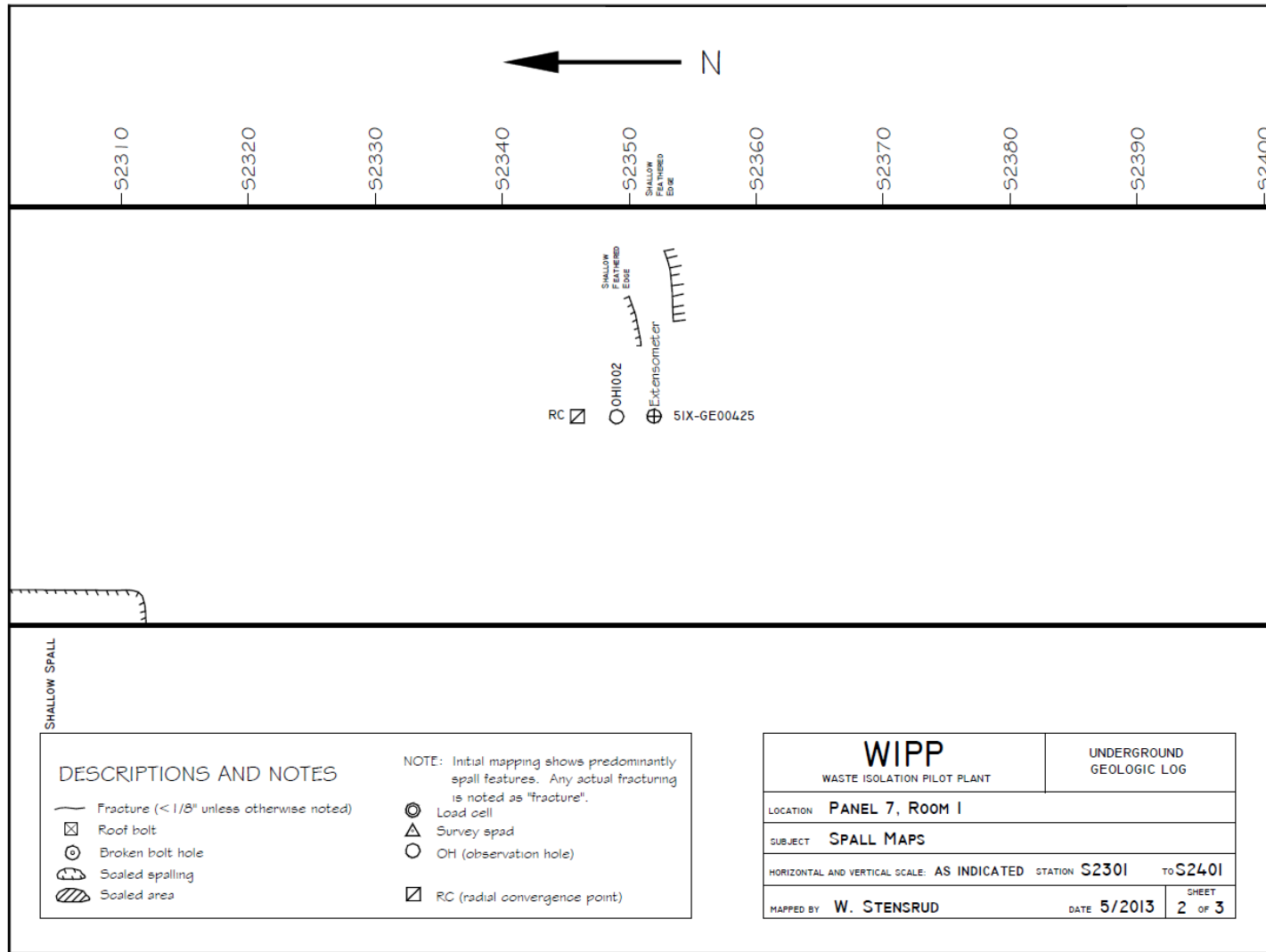

Figure 7-9
Panel 7 Room 1, S2301-S2401 Roof Fractures

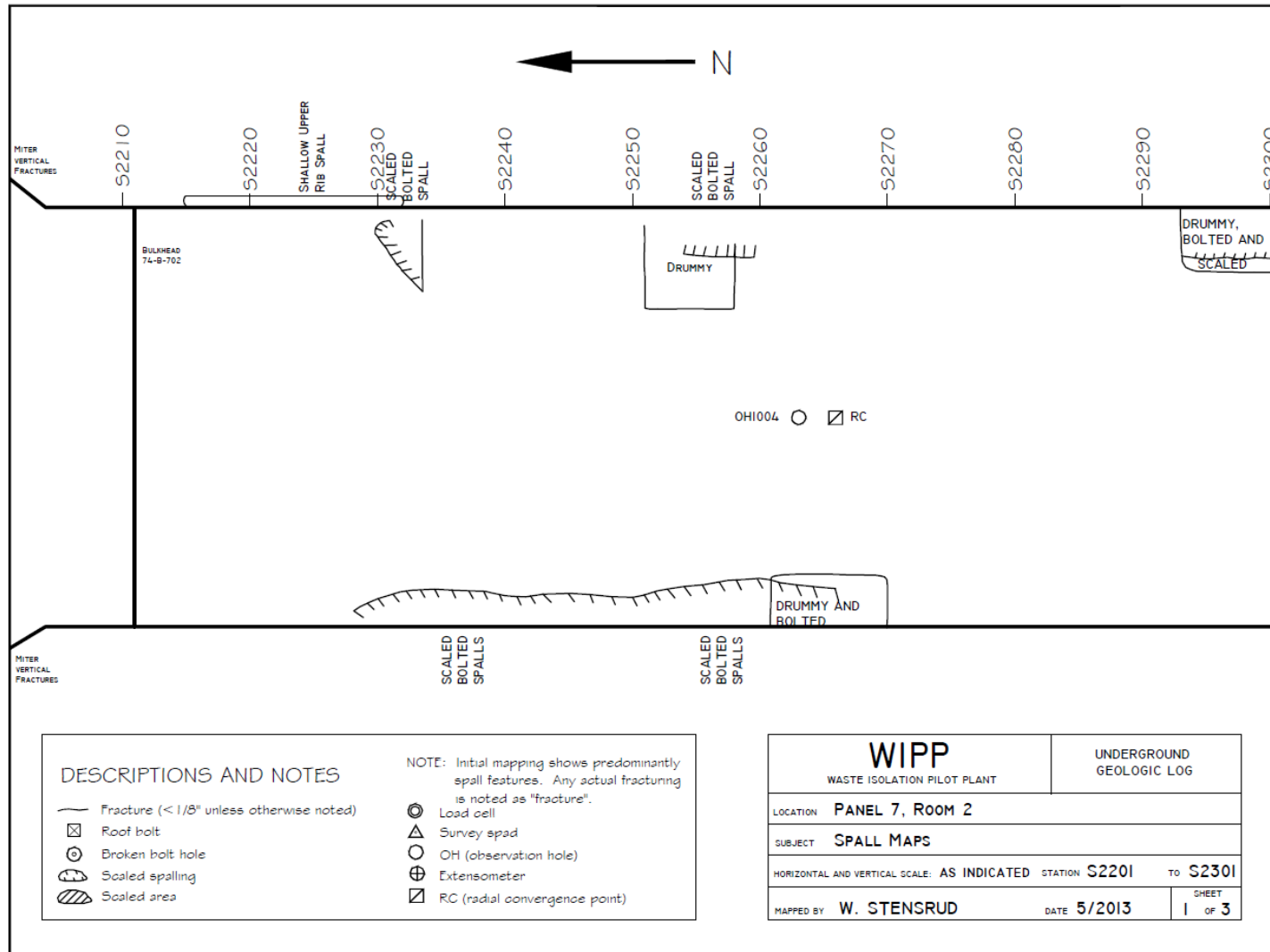

Figure 7-11
Panel 7 Room 2, S2201-S2301 Roof Fractures

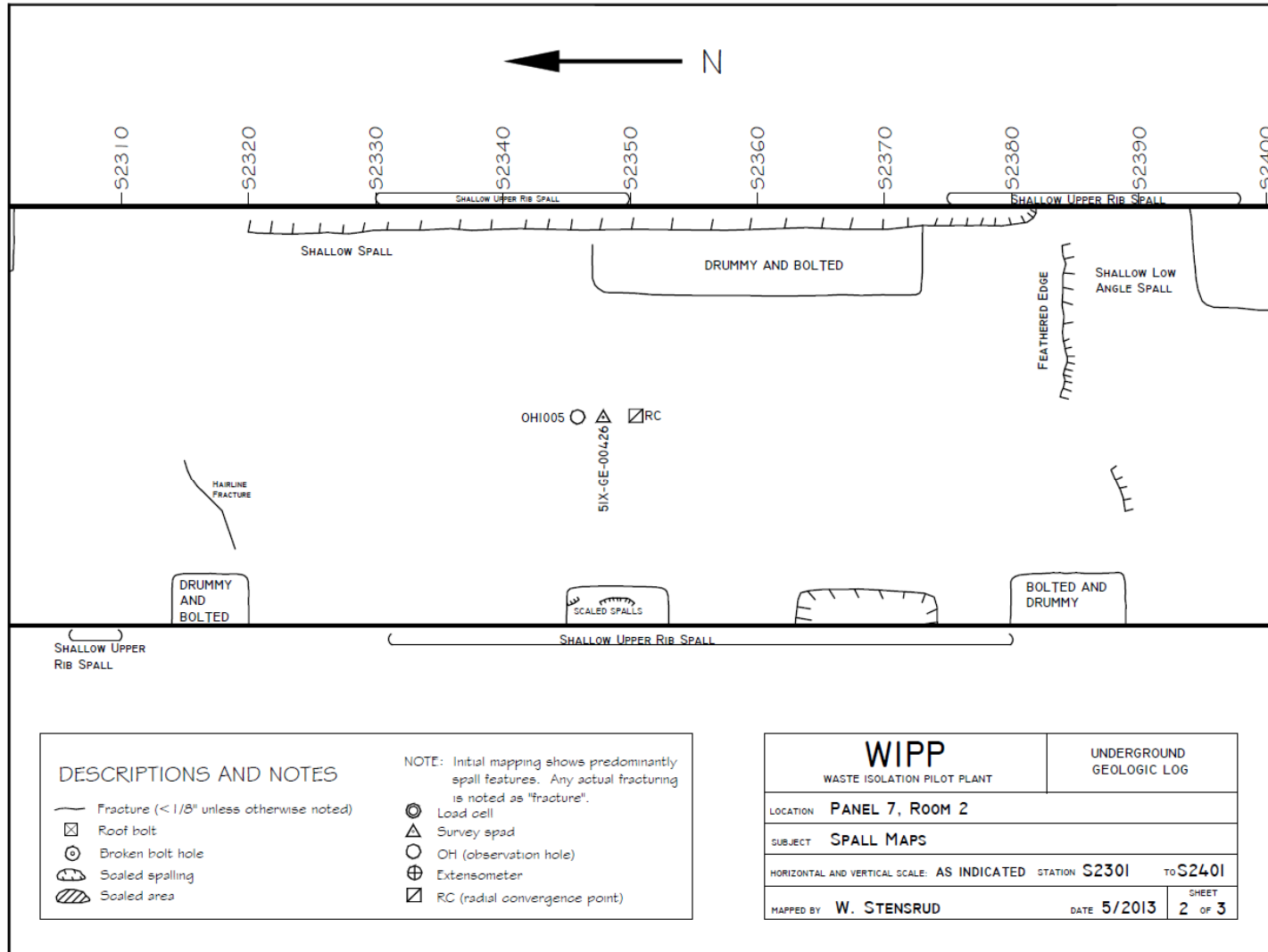

Figure 7-12
Panel 7 Room 2, S2301-S2401 Roof Fractures

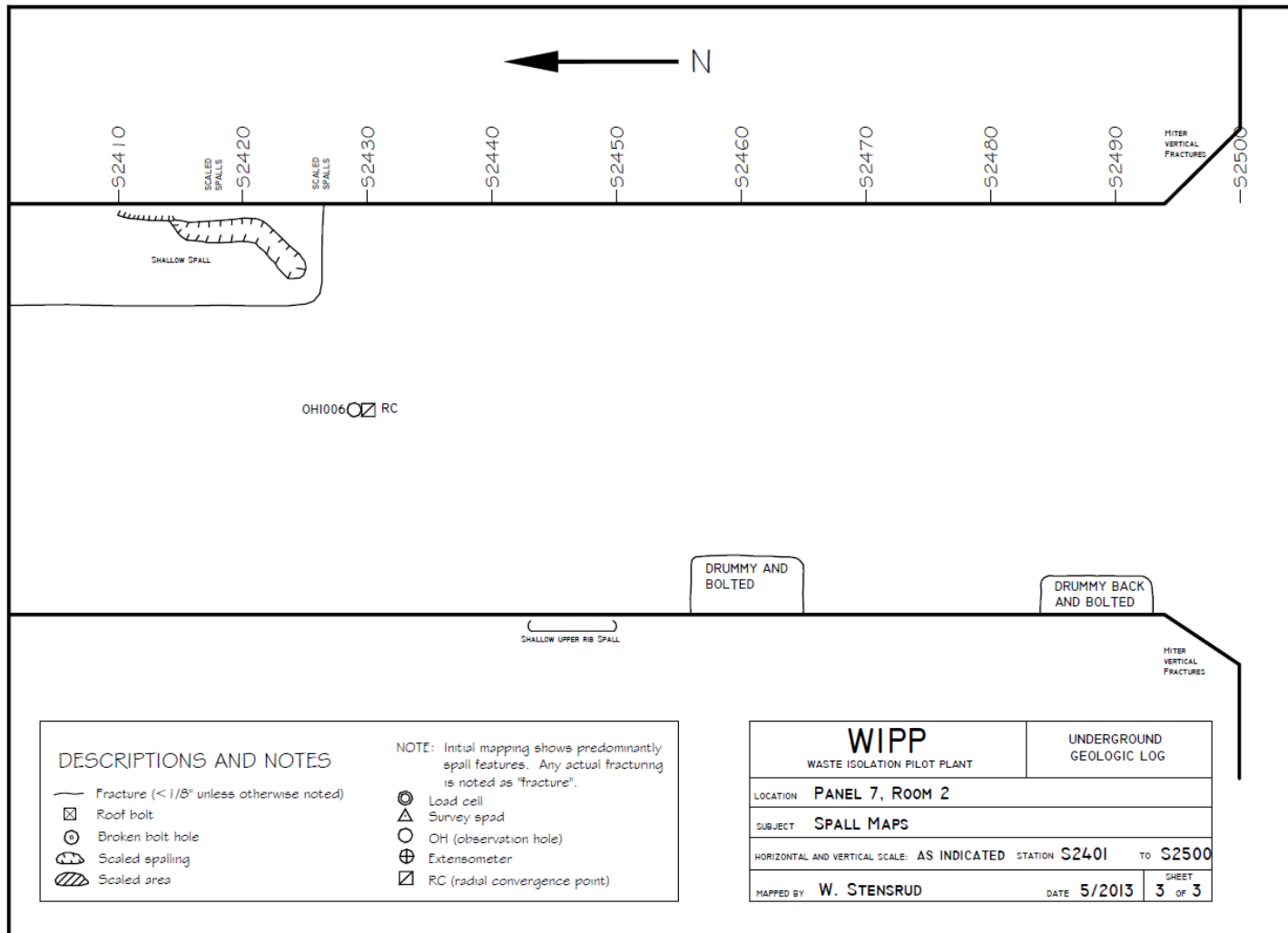

Figure 7-13
Panel 7 Room 2, S2401-S2500 Roof Fractures

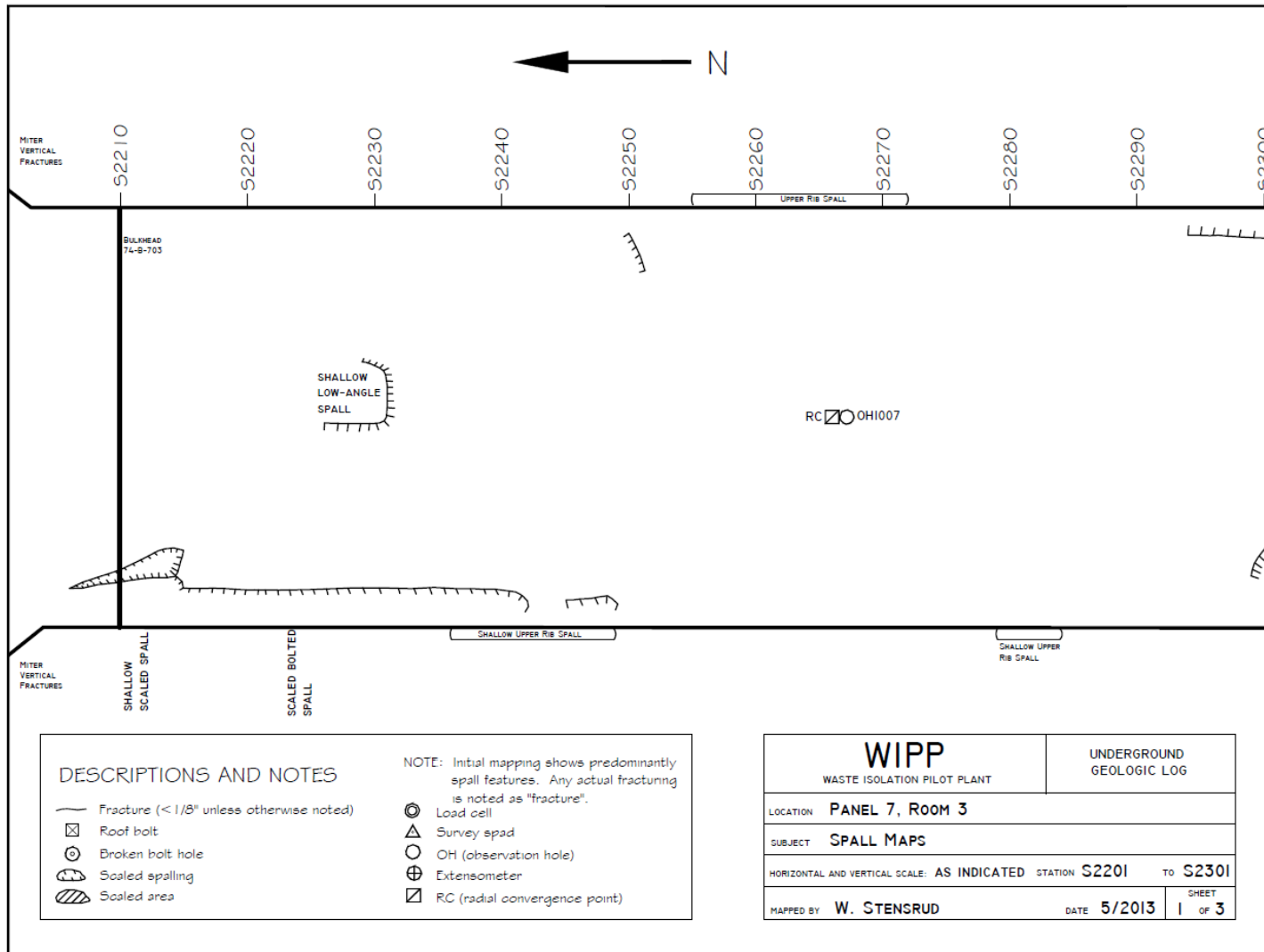

Figure 7-14
Panel 7 Room 3, S2201-S2301 Roof Fractures

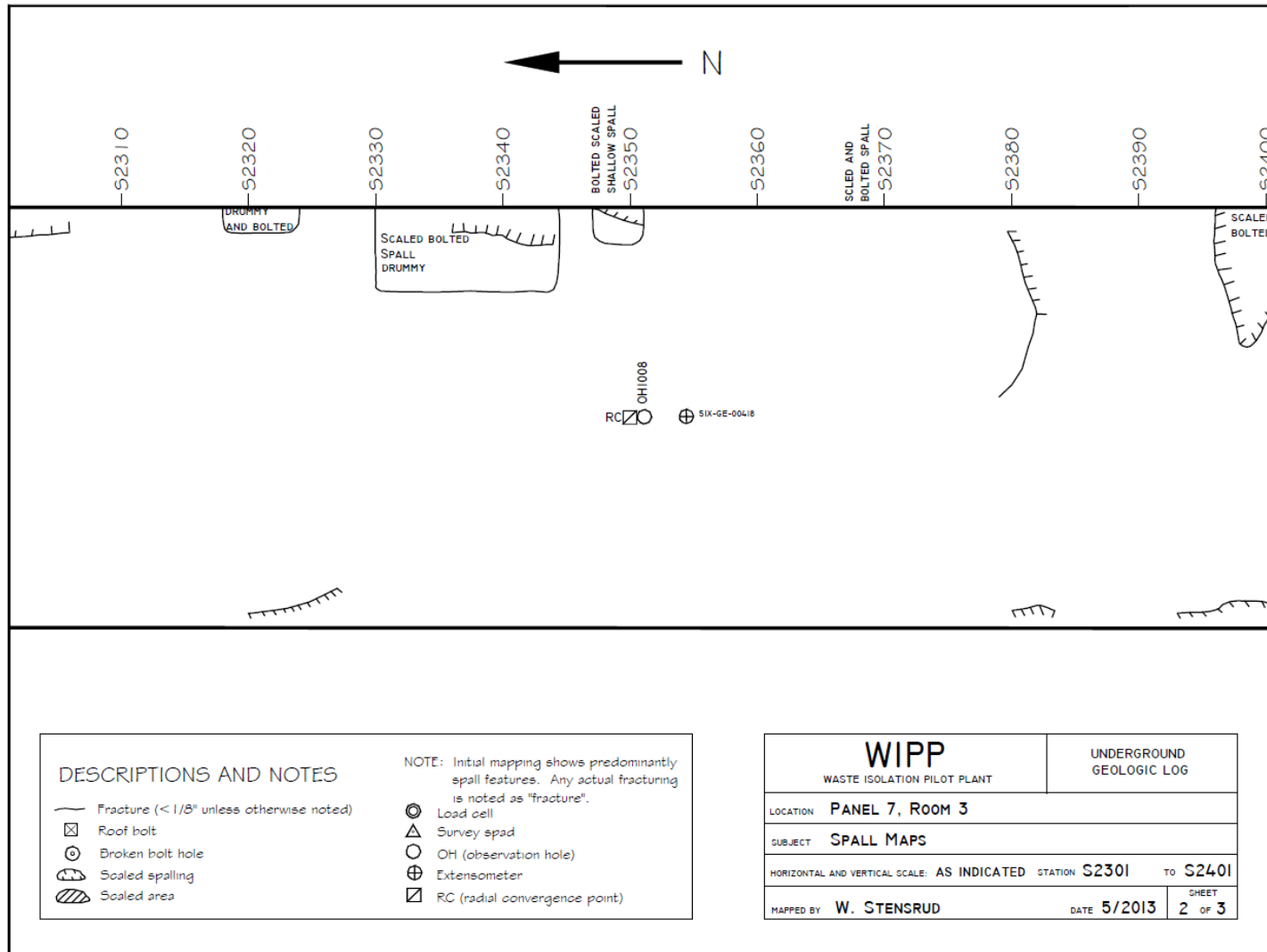

Figure 7-15
Panel 7 Room 3, S2301-S2401 Roof Fractures

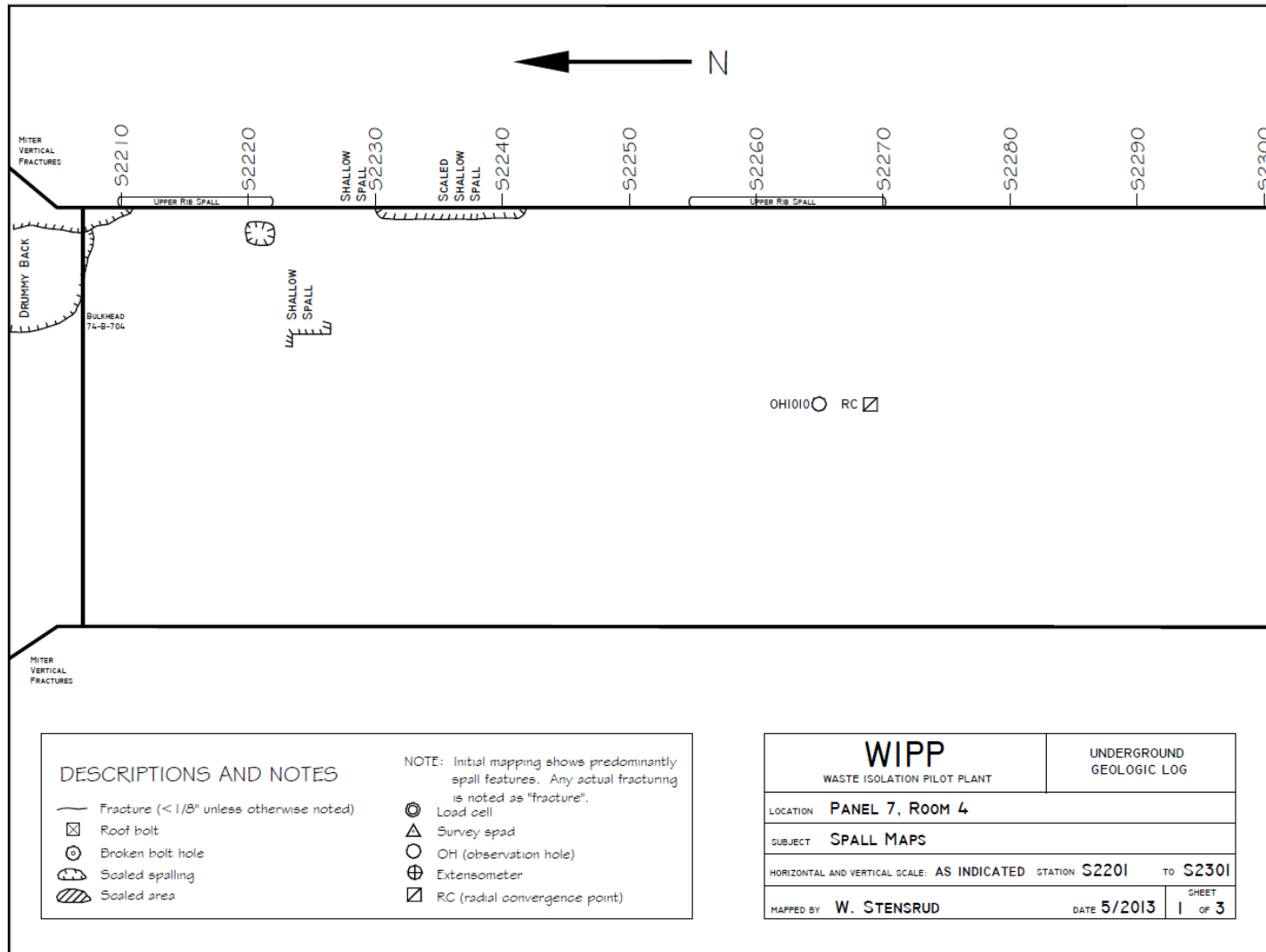

Figure 7-17
Panel 7 Room 4, S2201-S2301 Roof Fractures

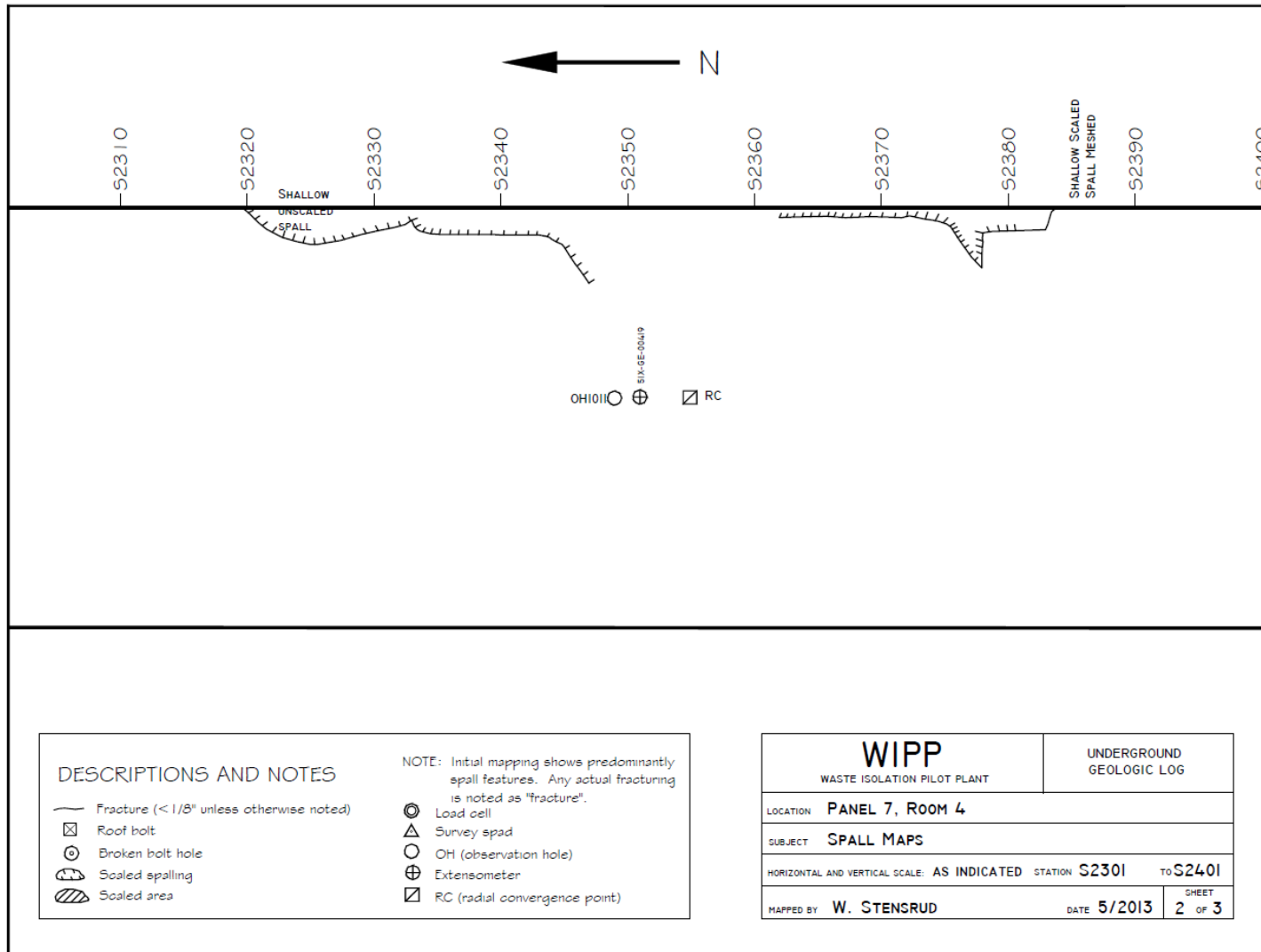

Figure 7-18
Panel 7 Room 4, S2301-S2401 Roof Fractures

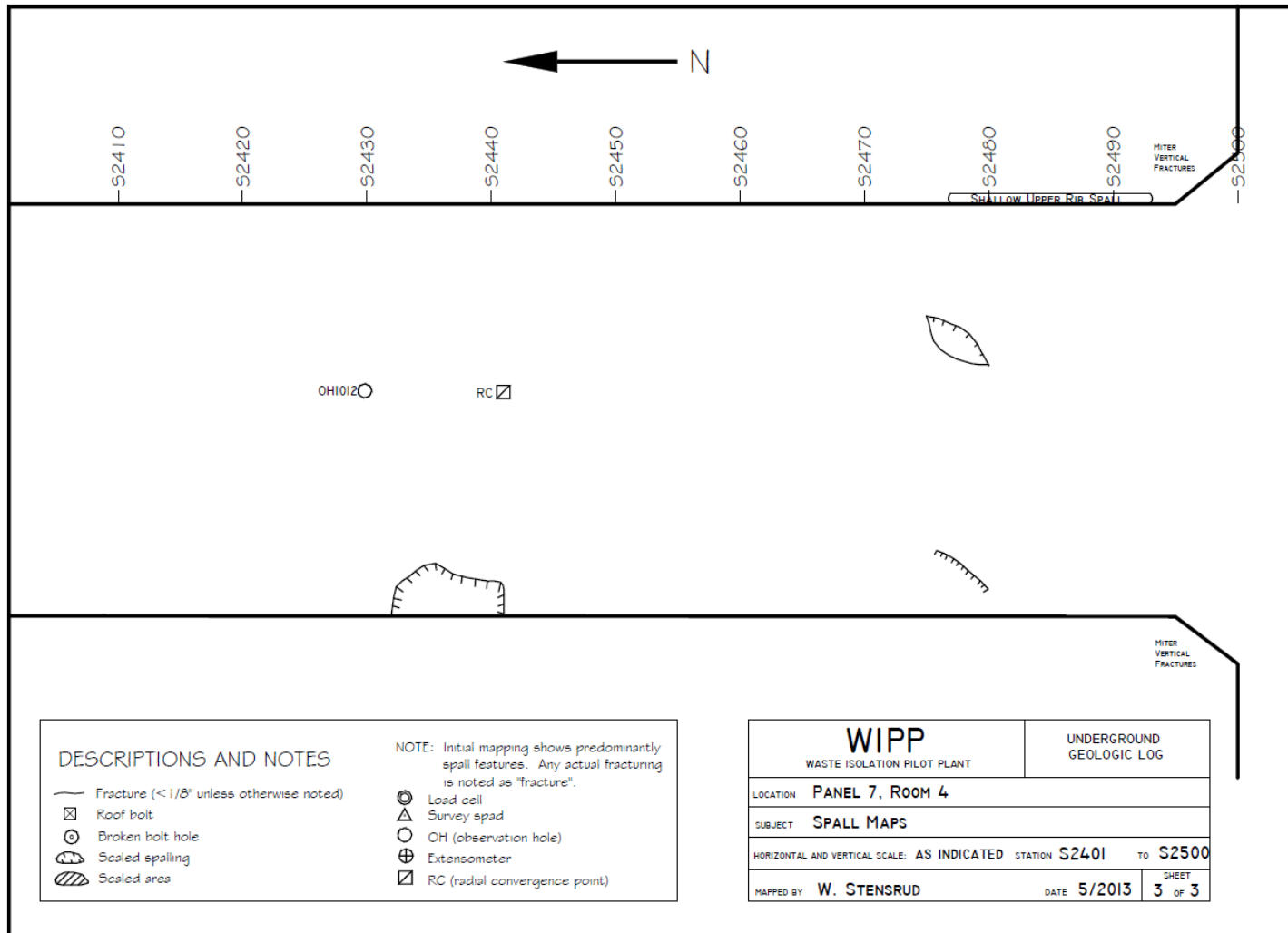

Figure 7-19
Panel 7 Room 4, S2401-S2500 Roof Fractures

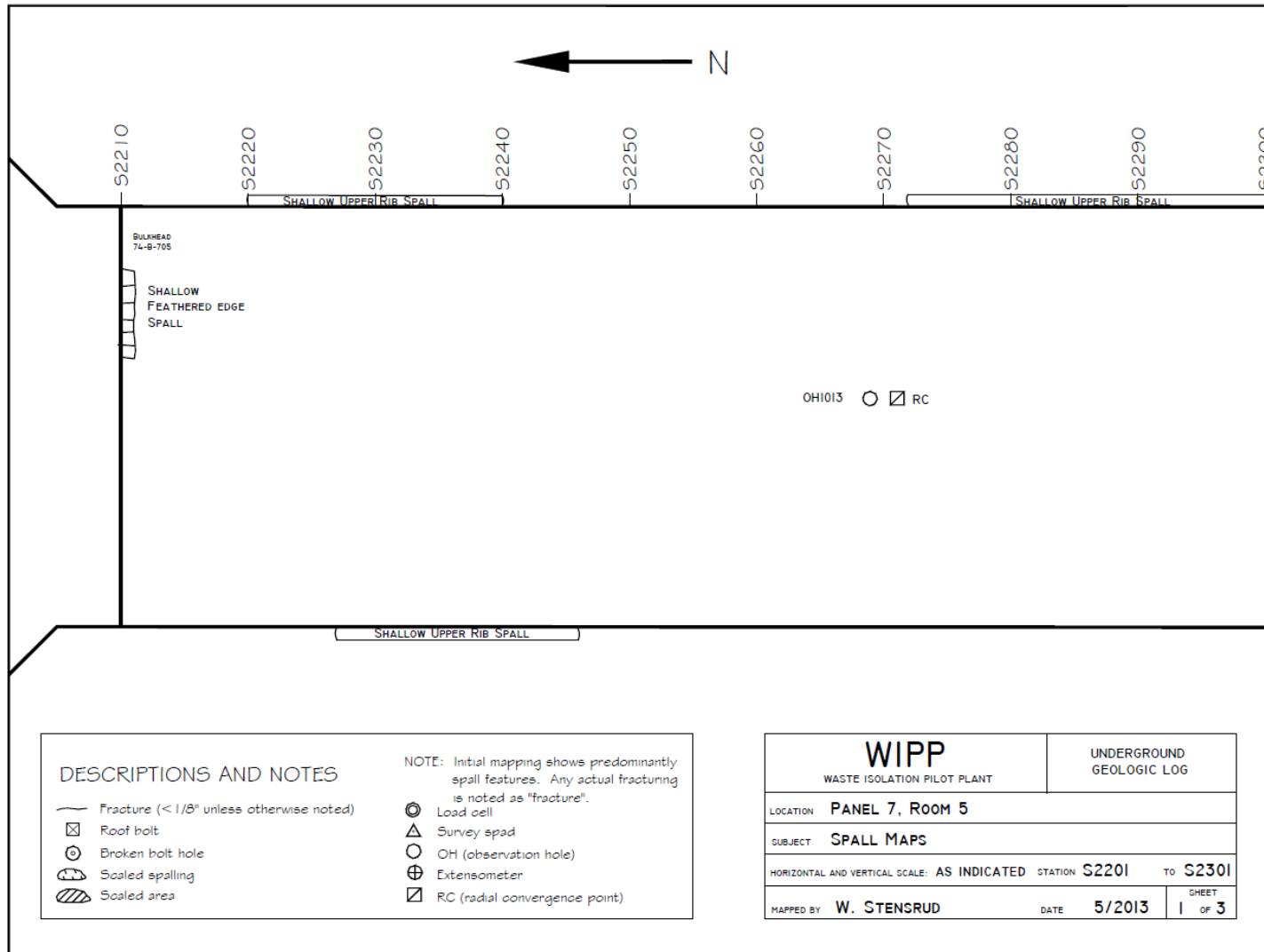

Figure 7-20
Panel 7 Room 5, S2201-S2301 Roof Fractures

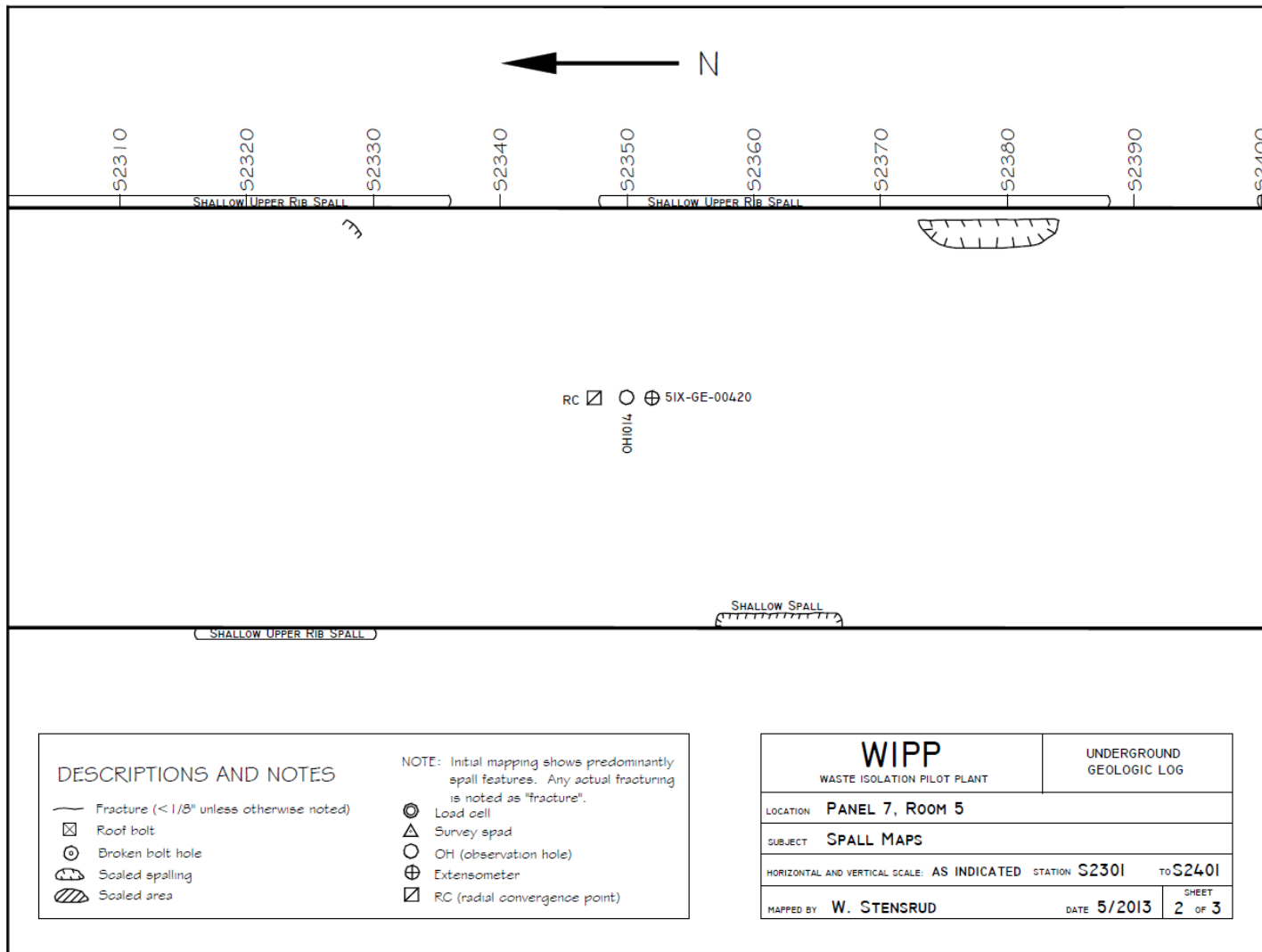

Figure 7-21
Panel 7 Room 5, S2301-S2401 Roof Fractures

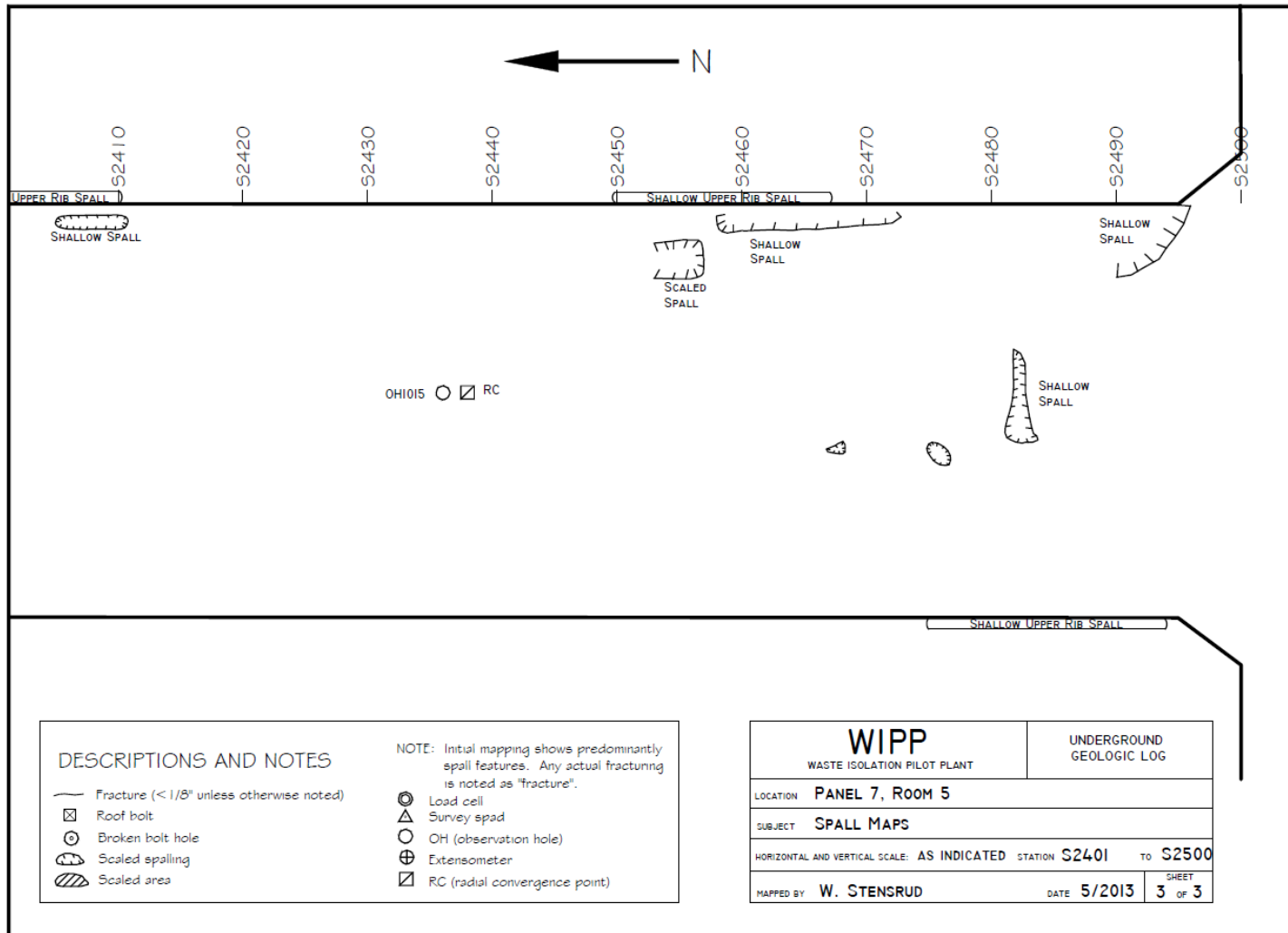

Figure 7-22
Panel 7 Room 5, S2401-S2500 Roof Fractures

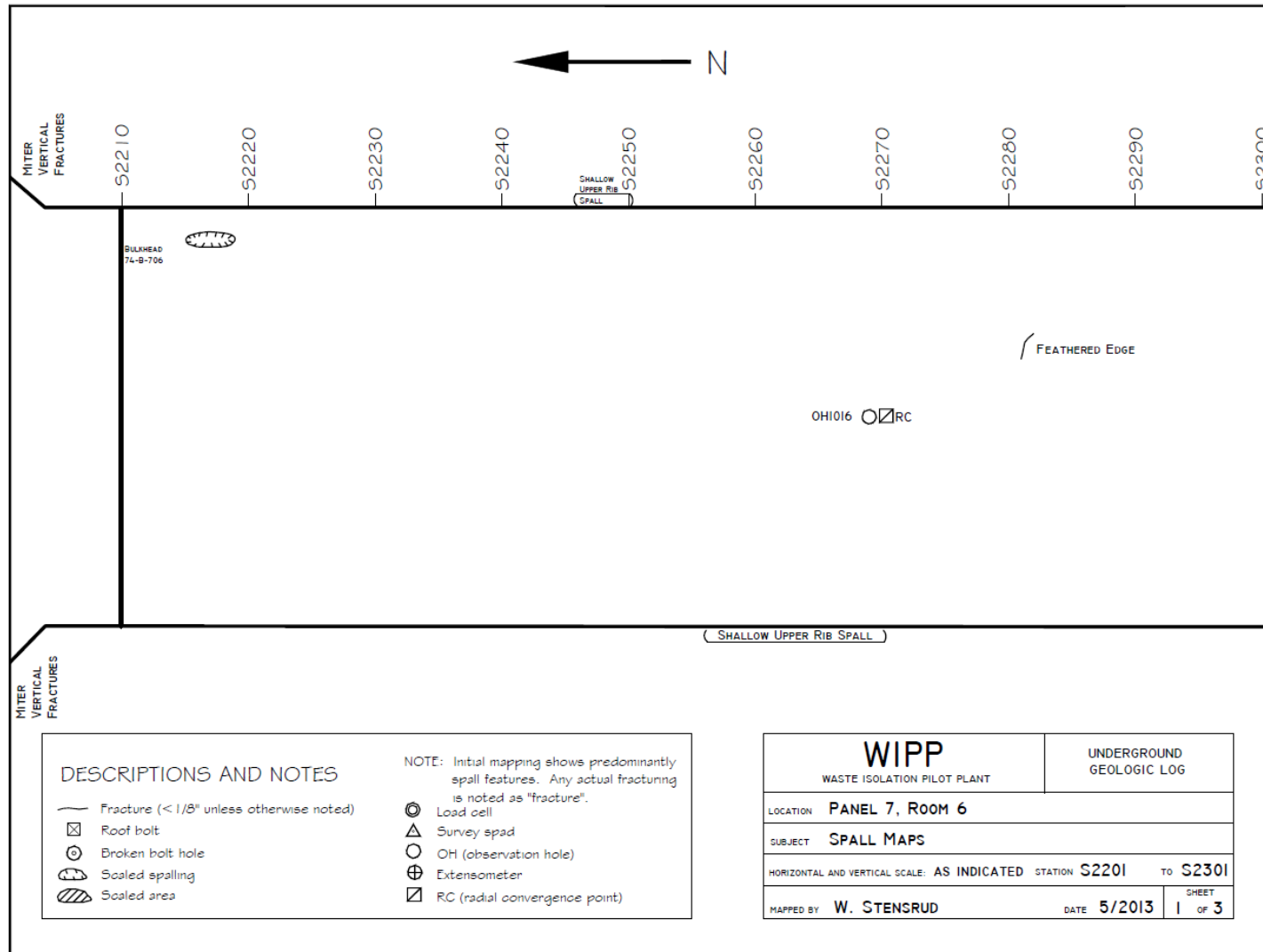

Figure 7-23
Panel 7 Room 6, S2201-S2301 Roof Fractures

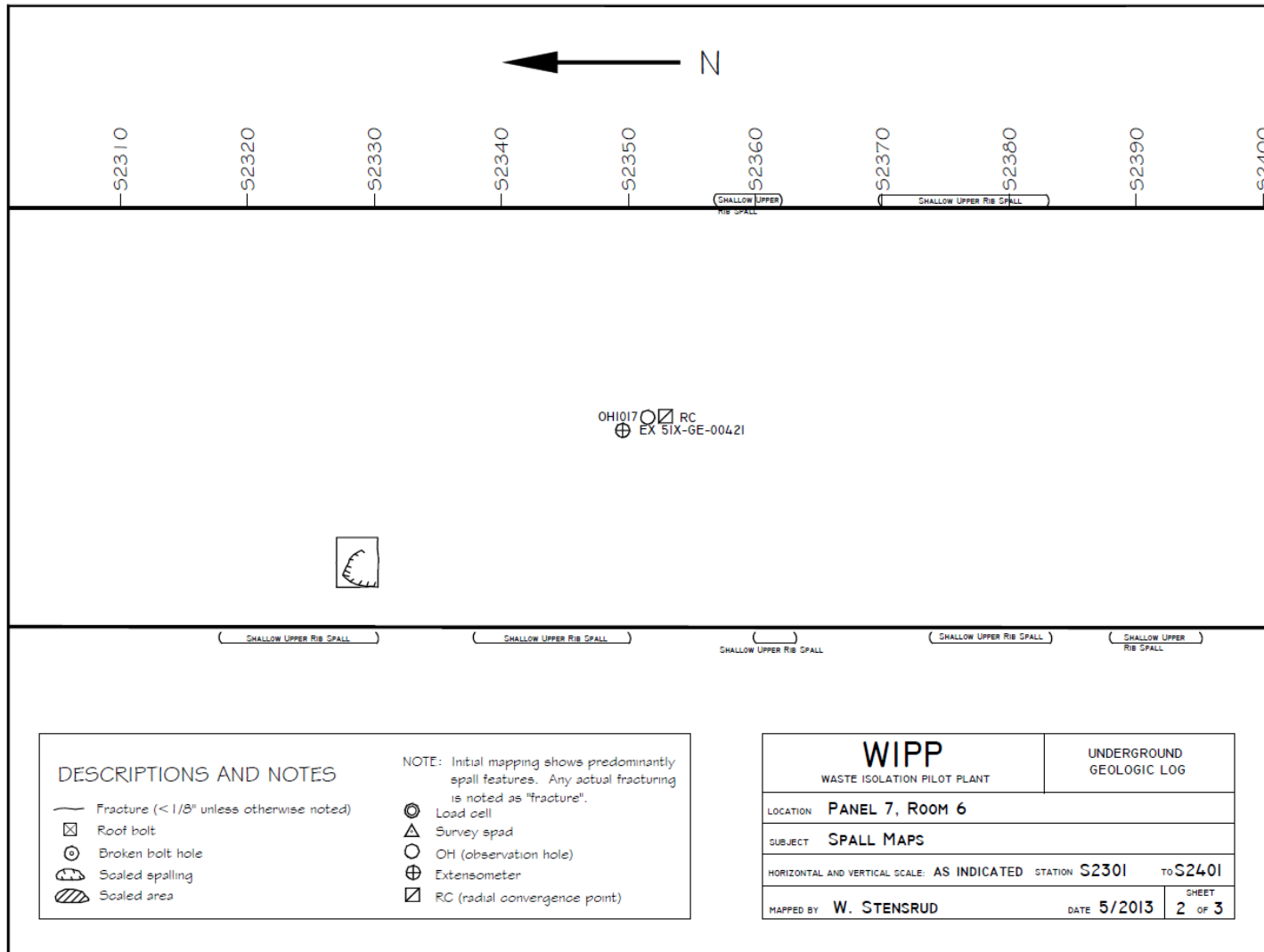

Figure 7-24
Panel 7 Room 6, S2301-S2401 Roof Fractures

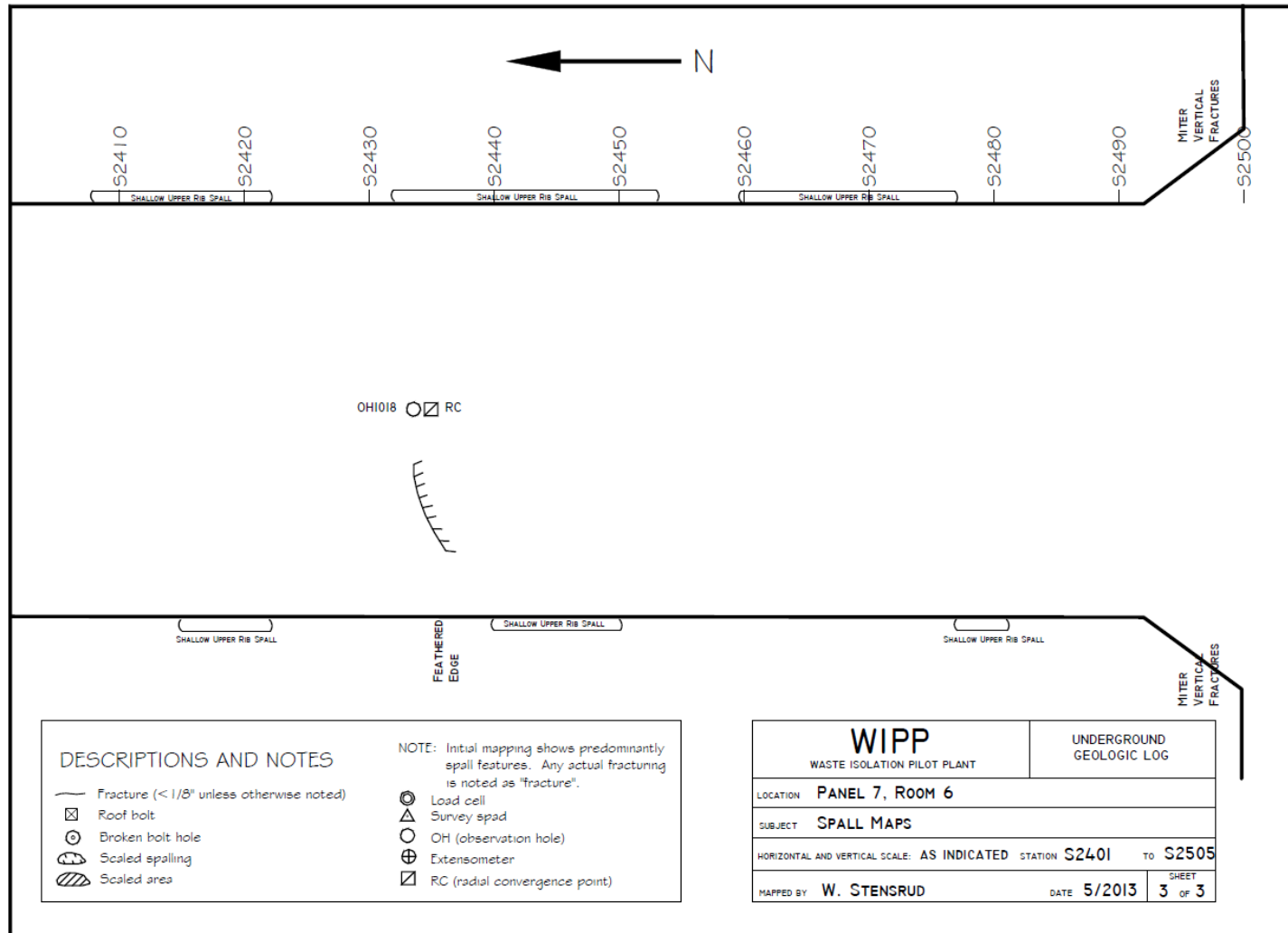

Figure 7-25
Panel 7 Room 6, S2401-S2505 Roof Fractures

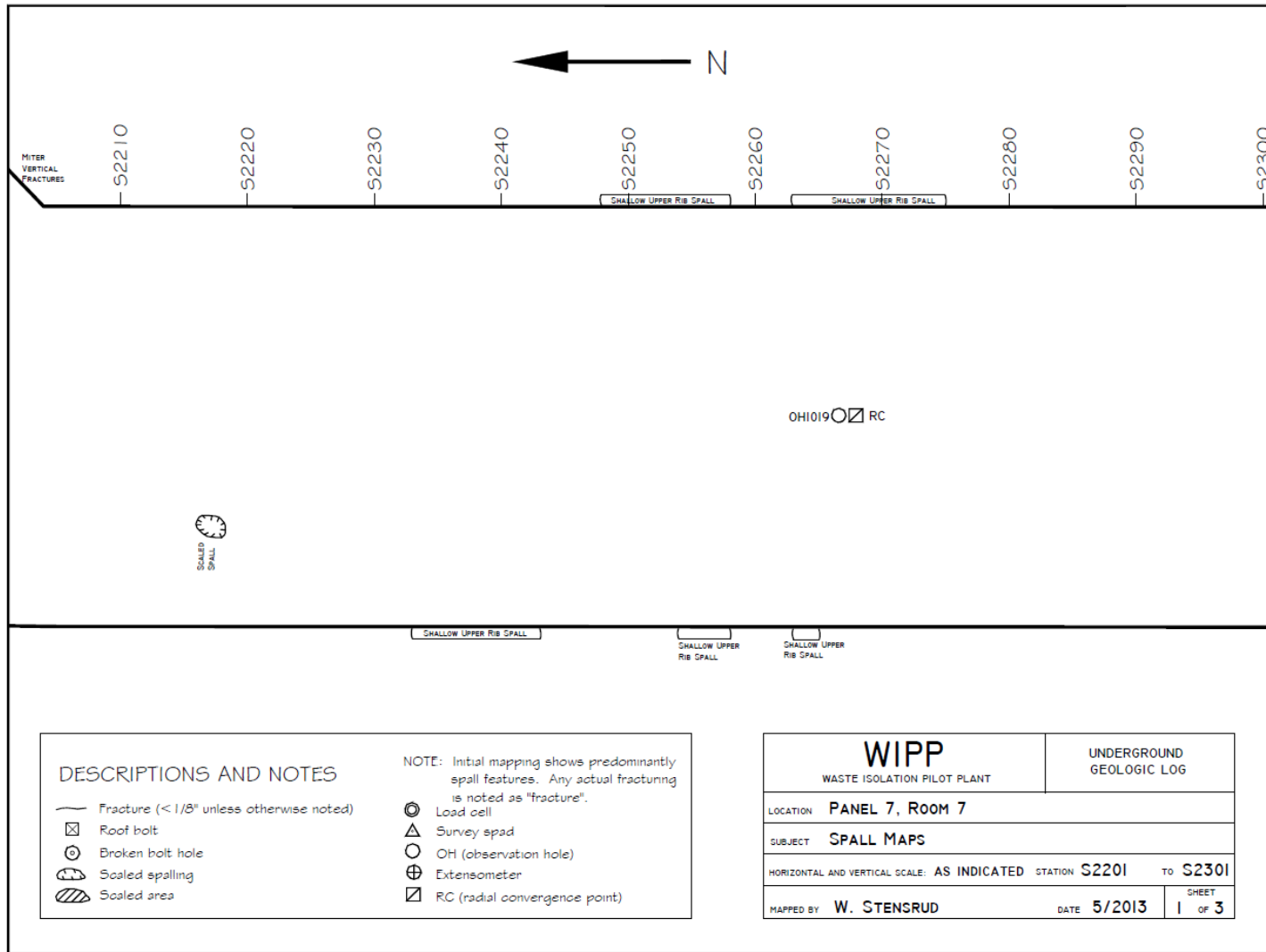

Figure 7-26
Panel 7 Room 7, S2201-S2301 Roof Fractures

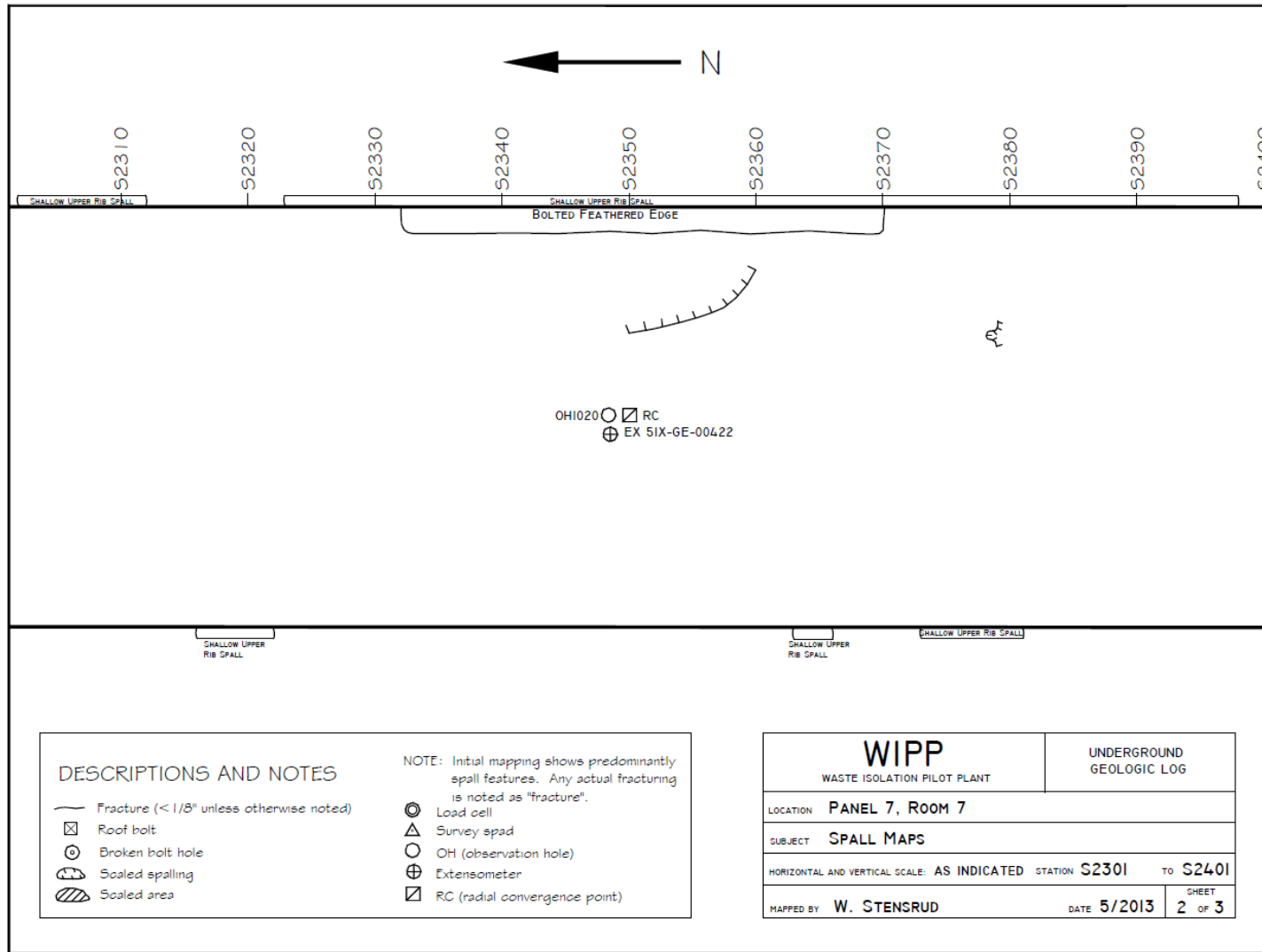

Figure 7-27
Panel 7 Room 7, S2301-S2401 Roof Fractures

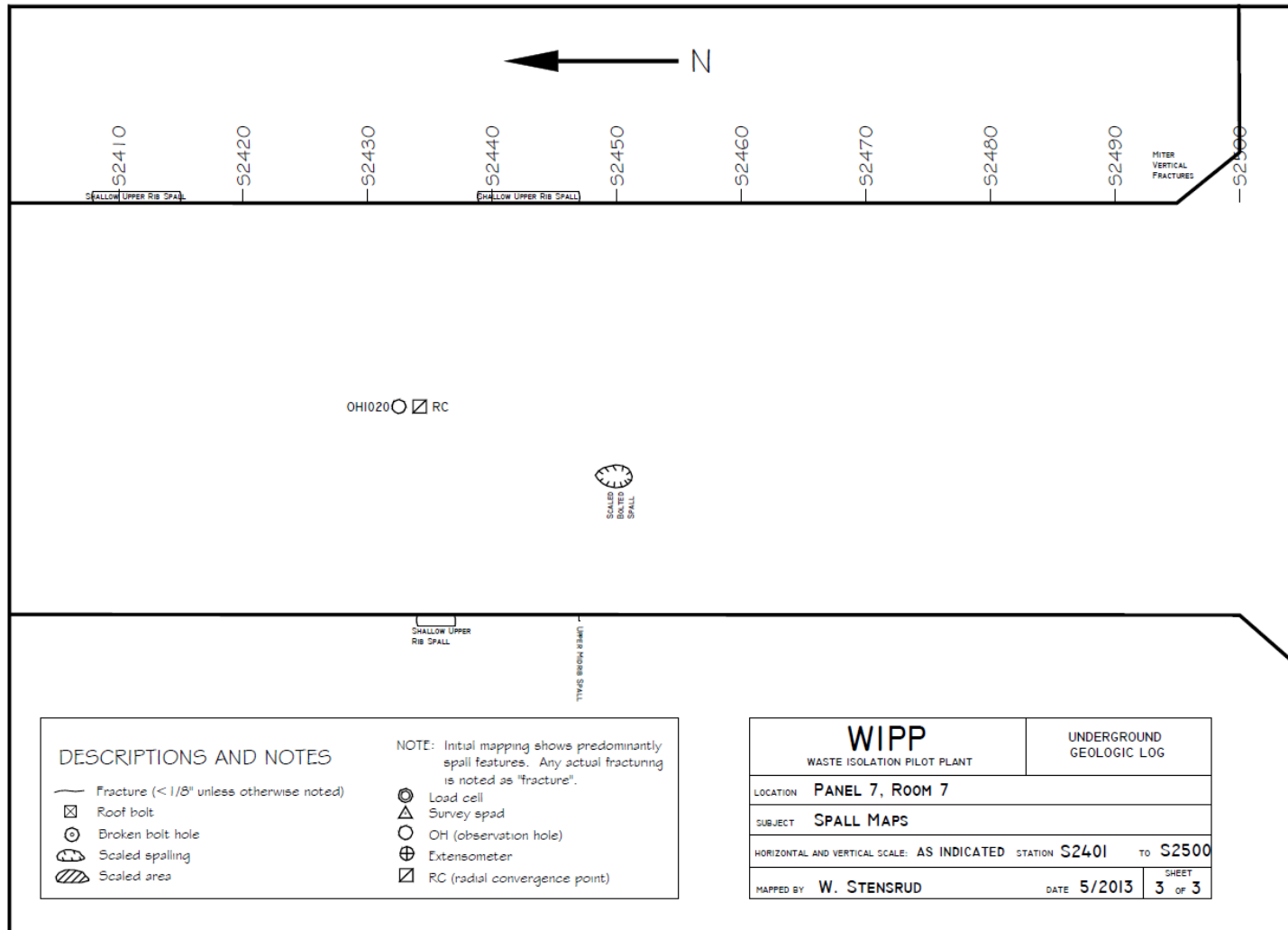

Figure 7-28
Panel 7 Room 7, S2401-S2500 Roof Fractures

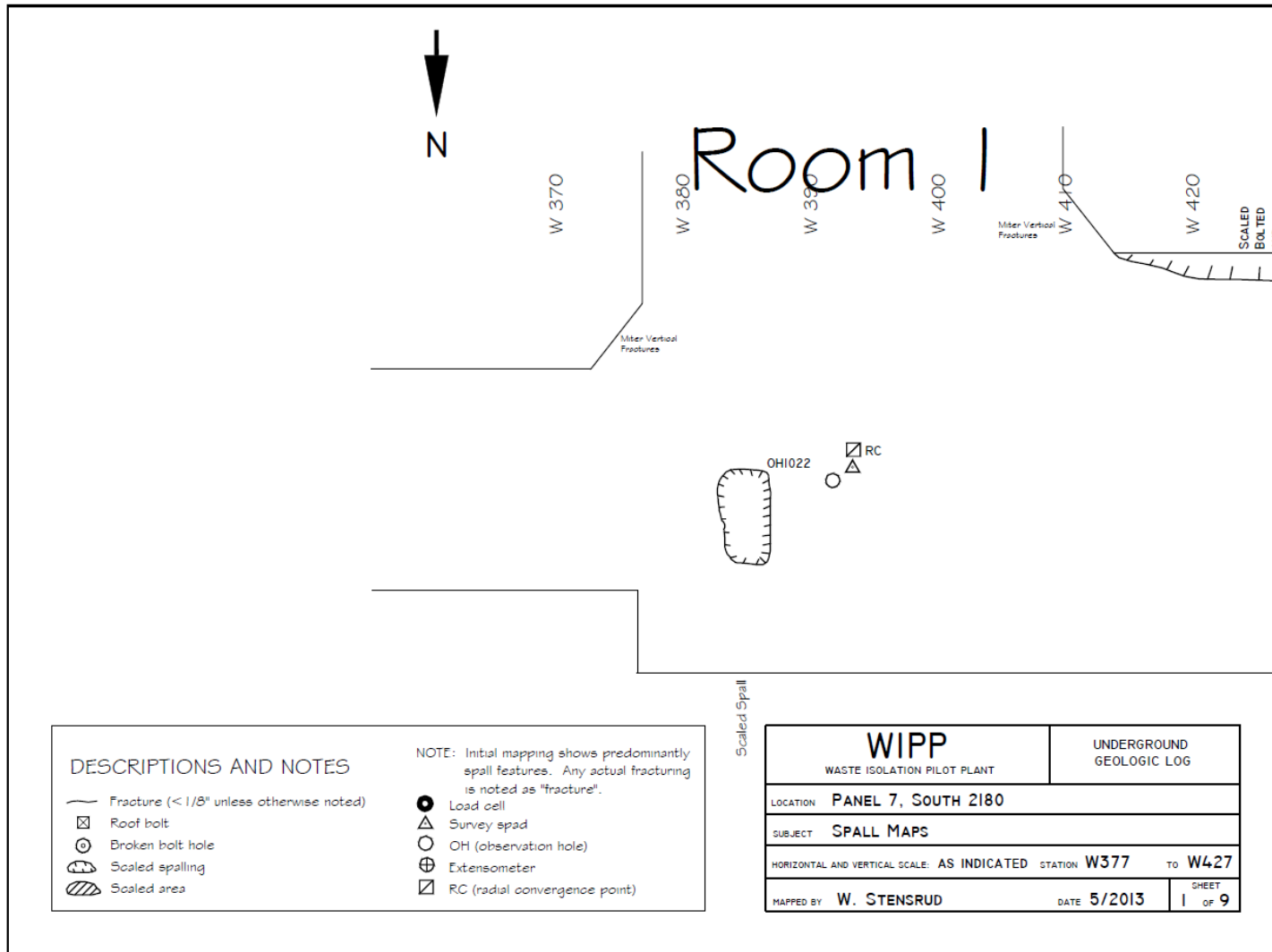

Figure 7-29
Panel 7 South 2180, W377-W427 Roof Fractures

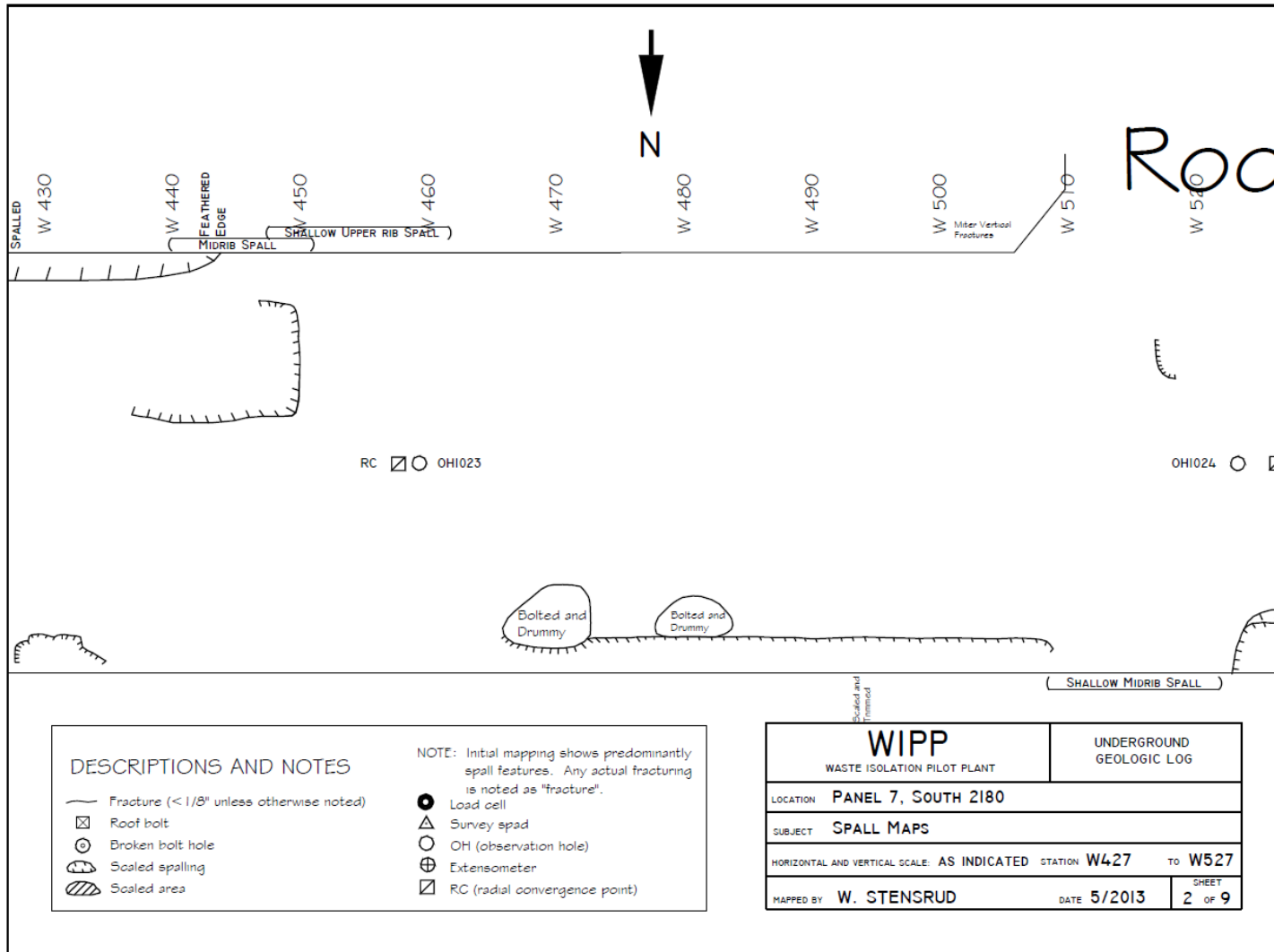
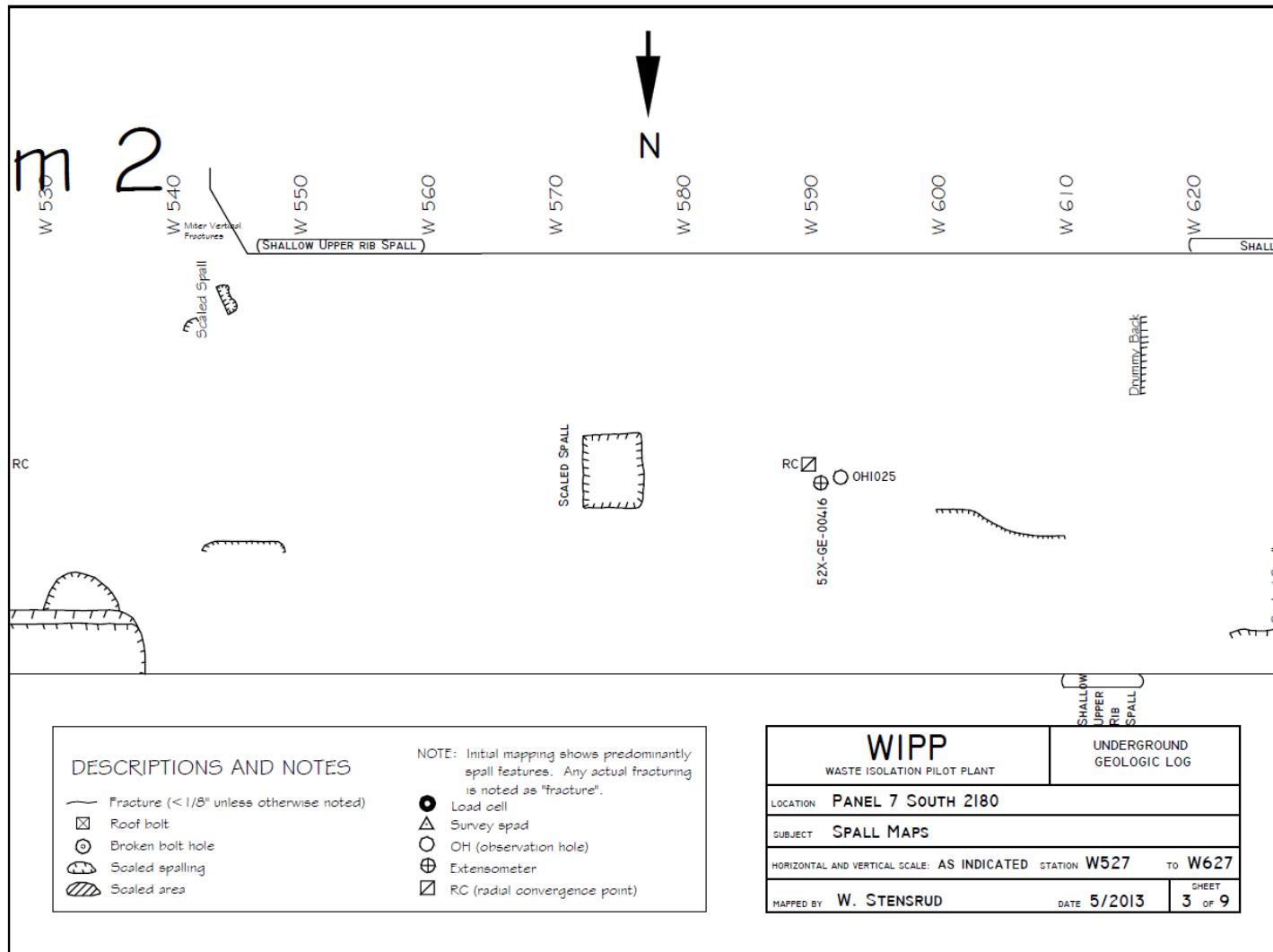

Figure 7-30
Panel 7 South 2180, W427-W527 Roof Fractures



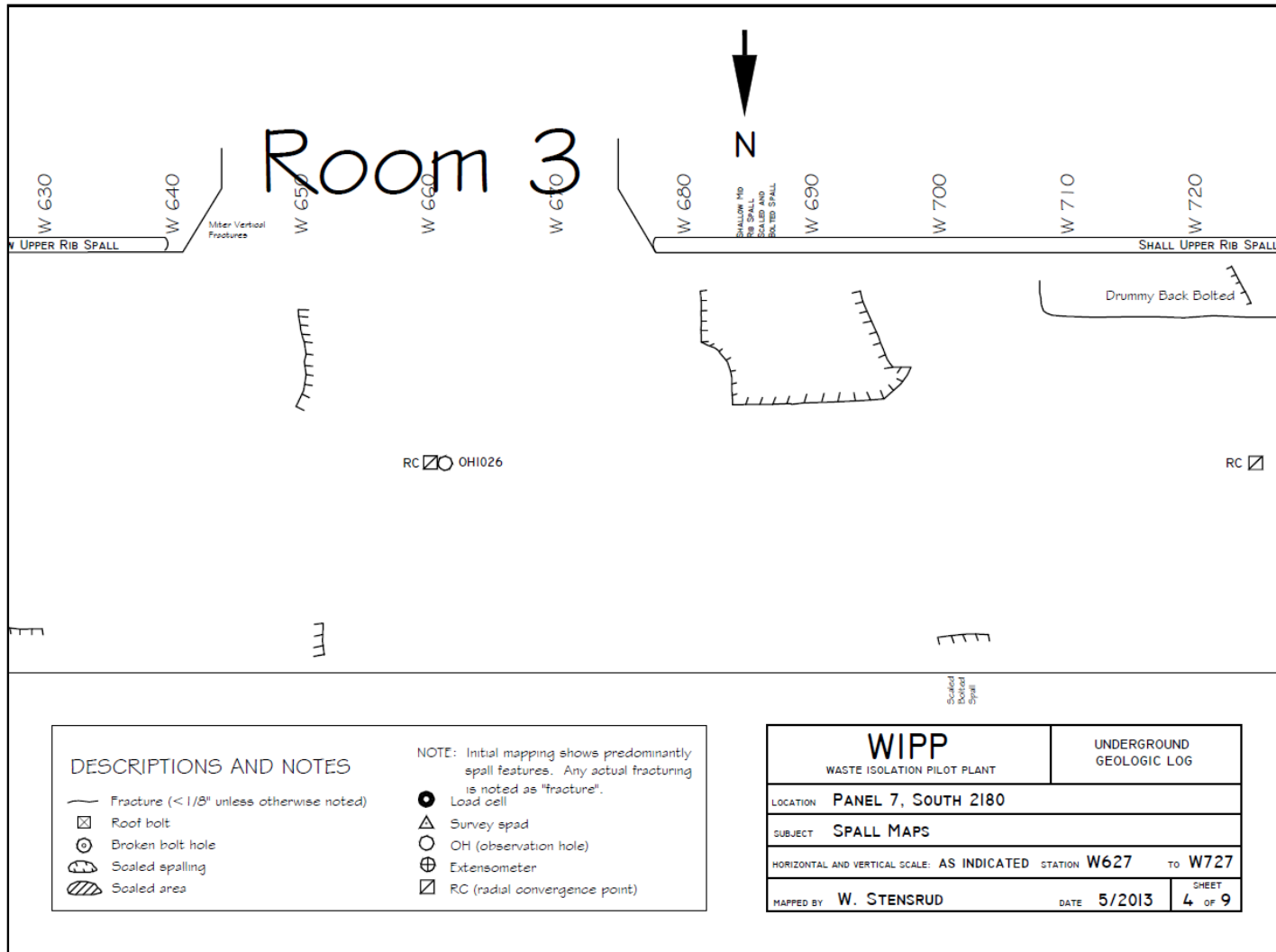

Figure 7-32
Panel 7 South 2180, W627-W727 Roof Fractures

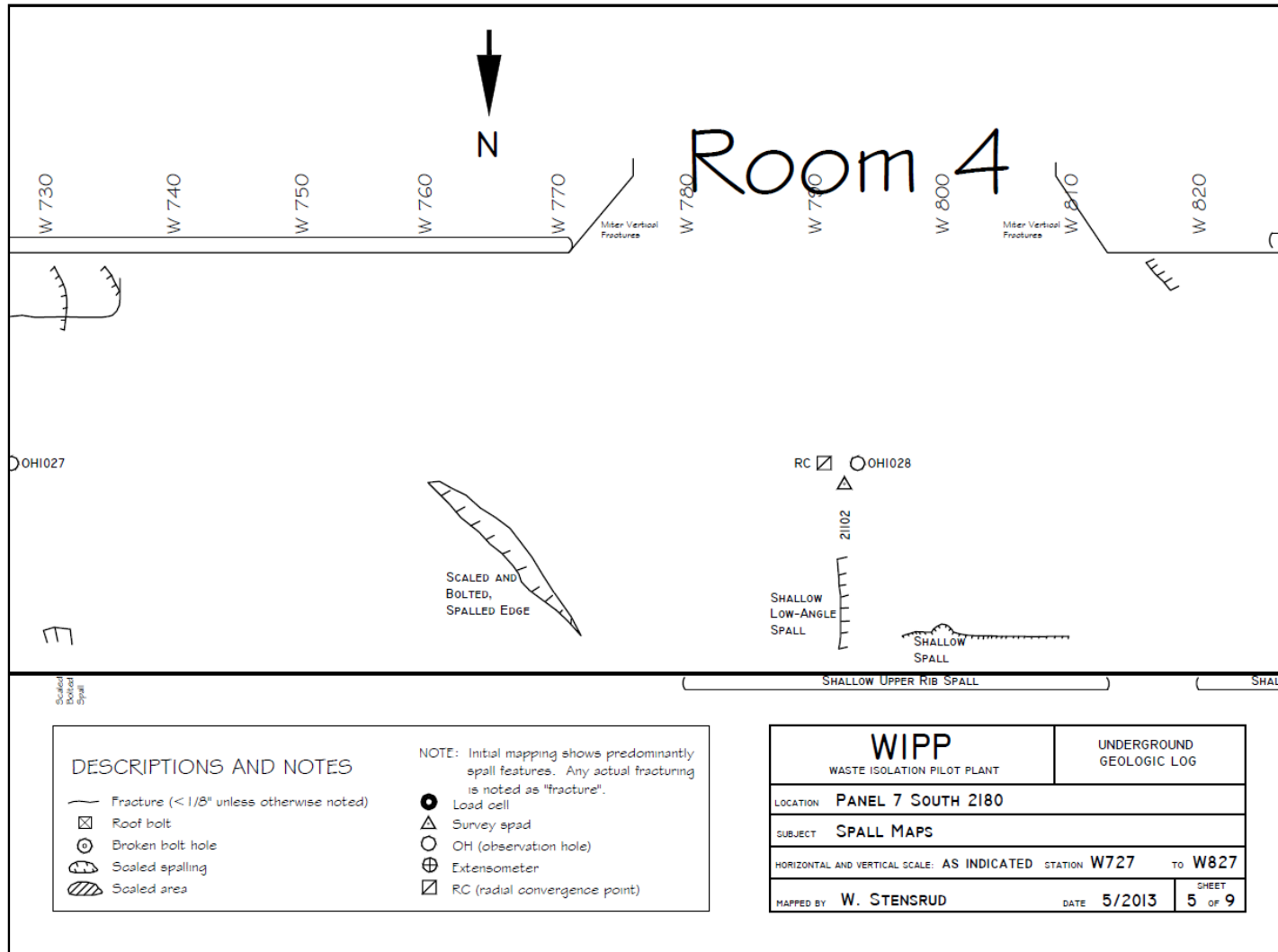

Figure 7-33
Panel 7 South 2180, W727-W827 Roof Fractures

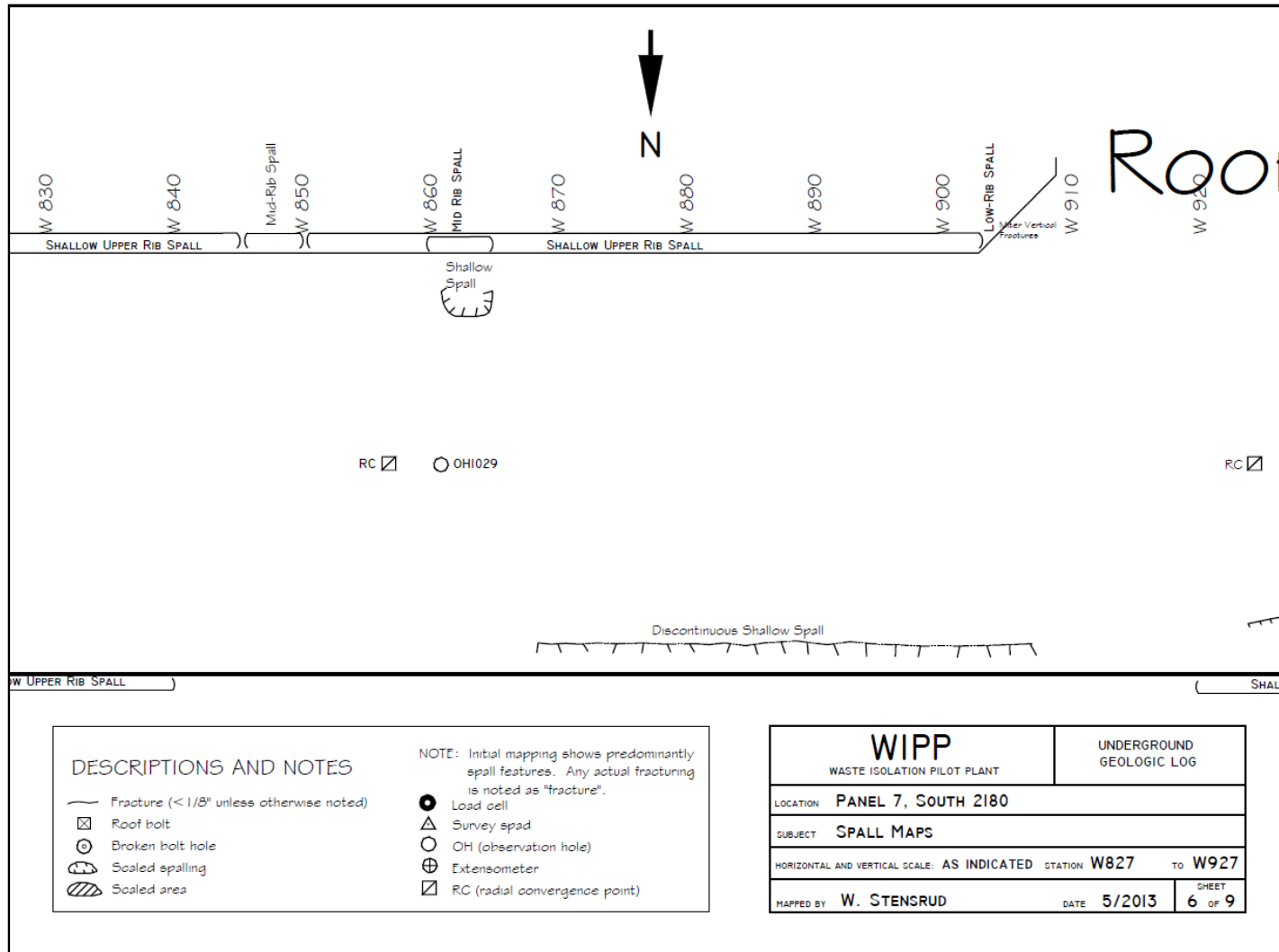

Figure 7-34
Panel 7 South 2180, W827-W927 Roof Fractures

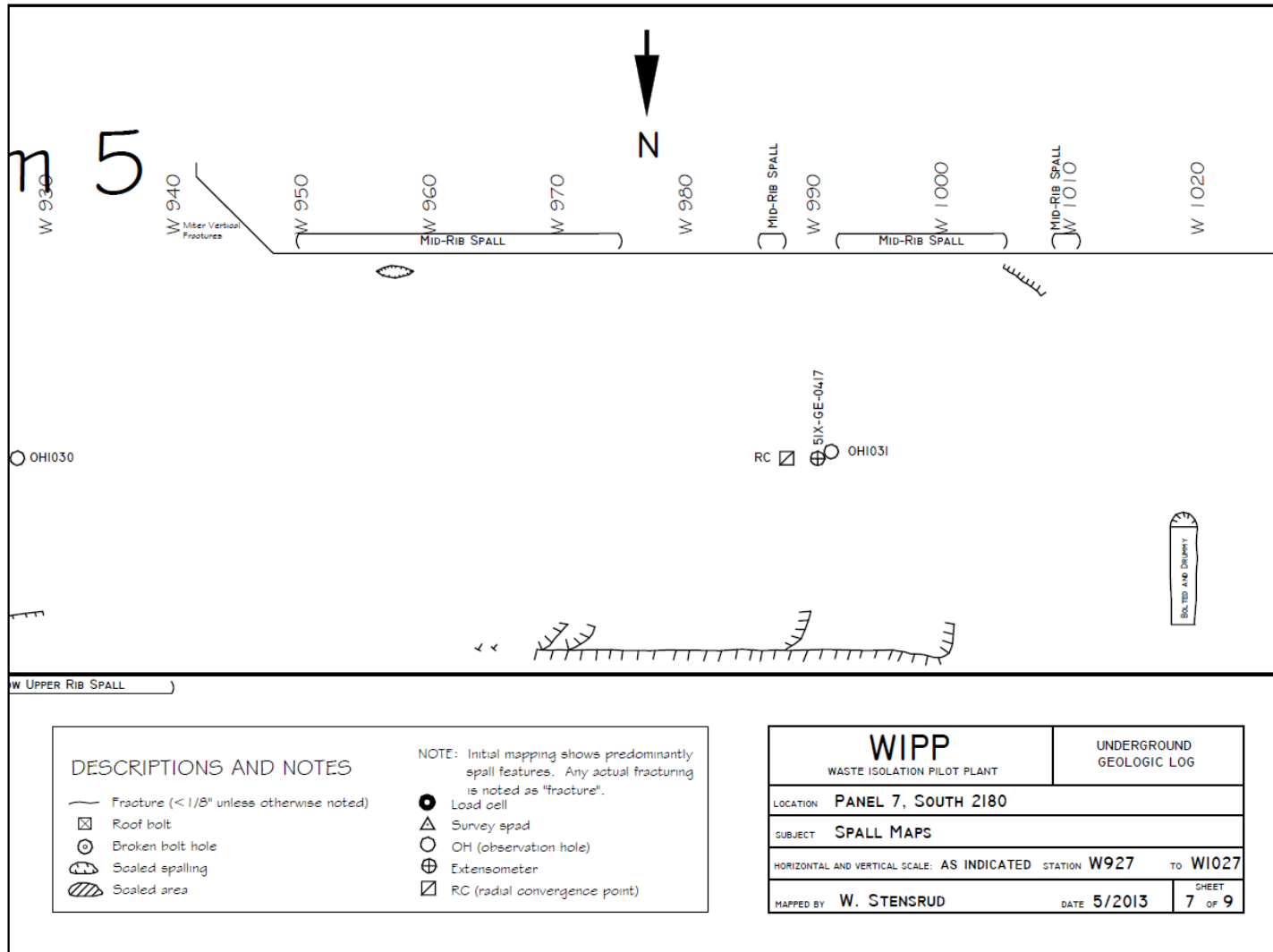

Figure 7-35
Panel 7 South 2180, W927-W1027 Roof Fractures

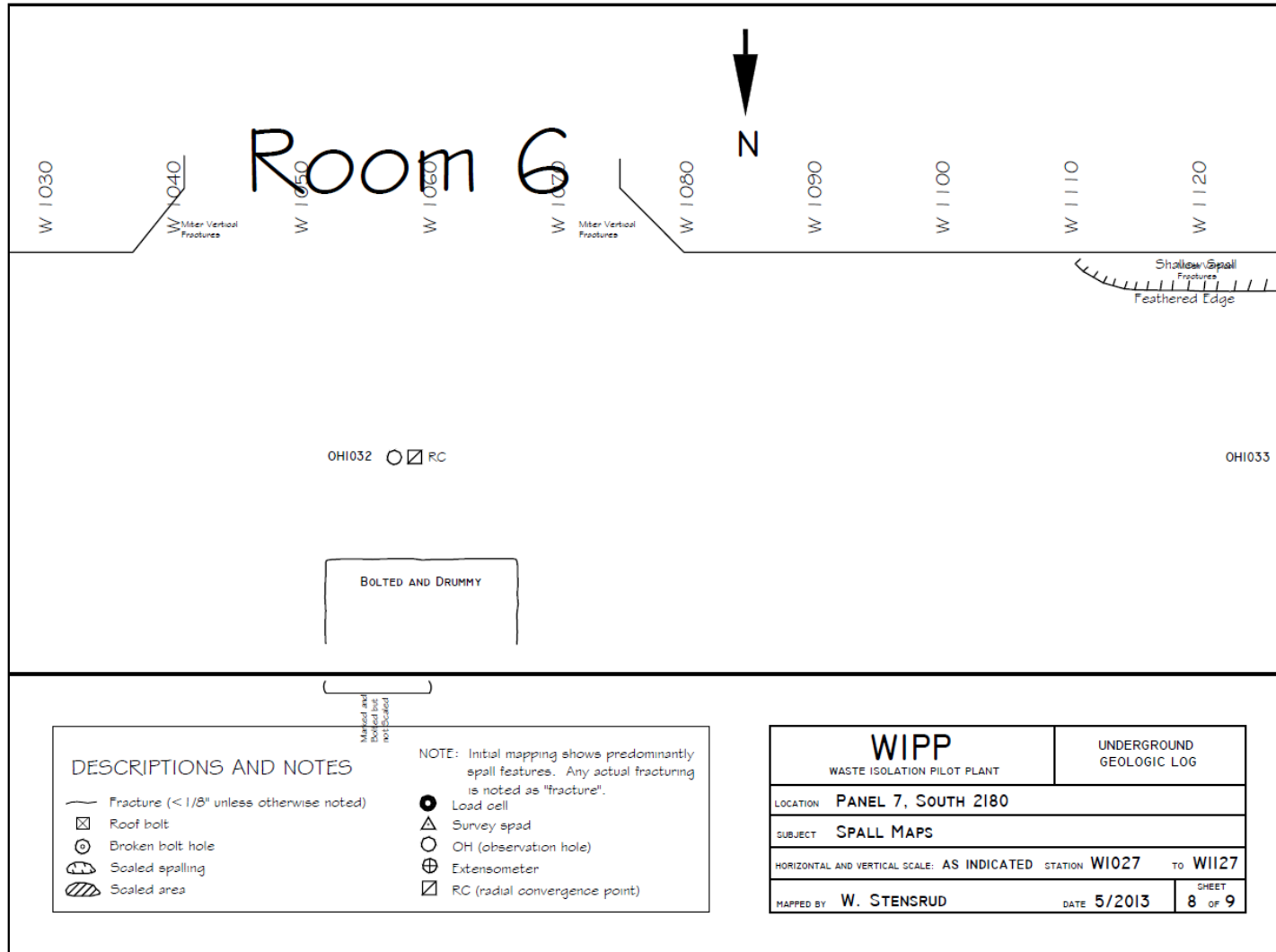

Figure 7-36
Panel 7 South 2180, W1027-W1127 Roof Fractures

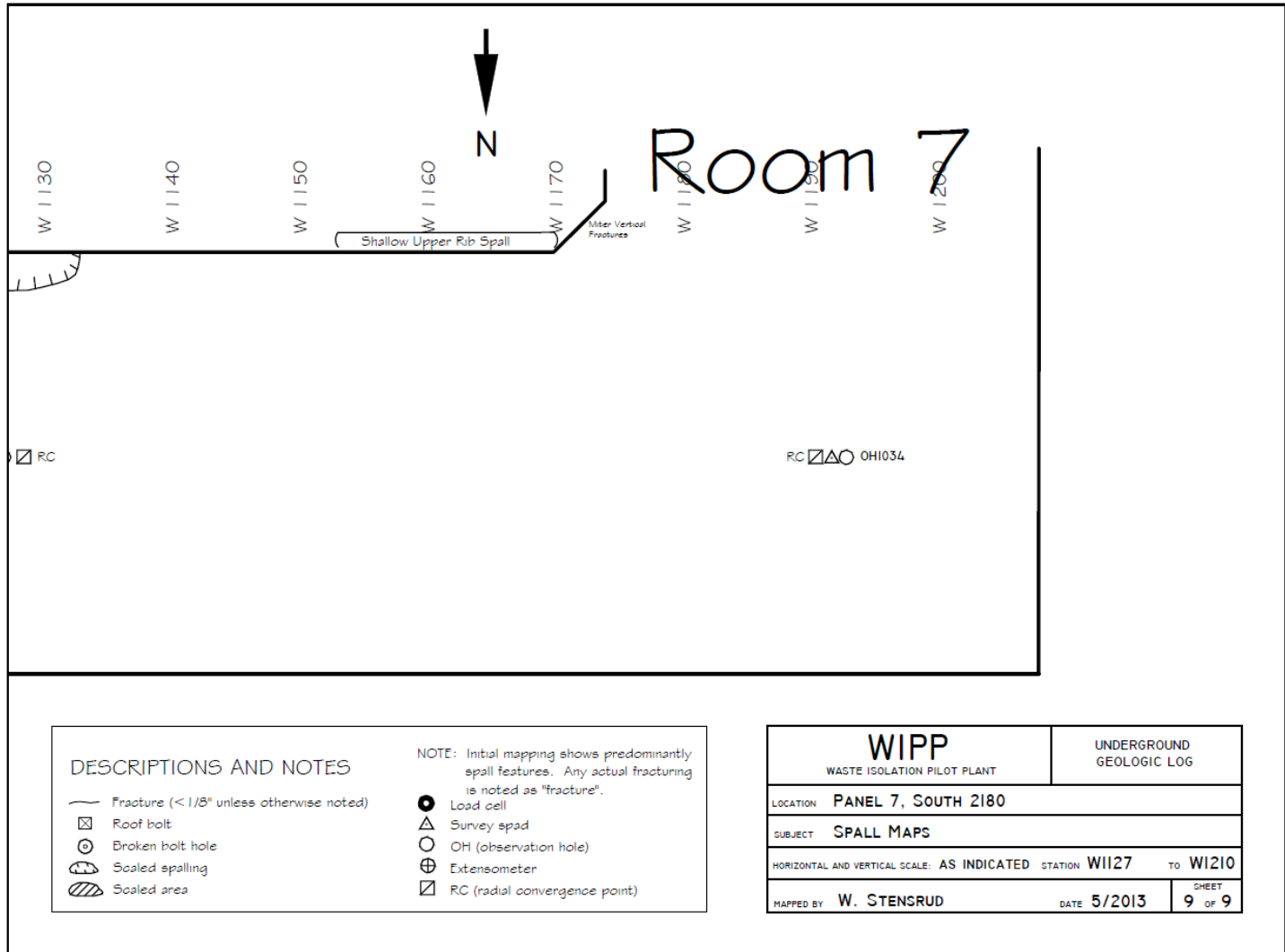

Figure 7-37
Panel 7 South 2180, W1127-W1210 Roof Fractures

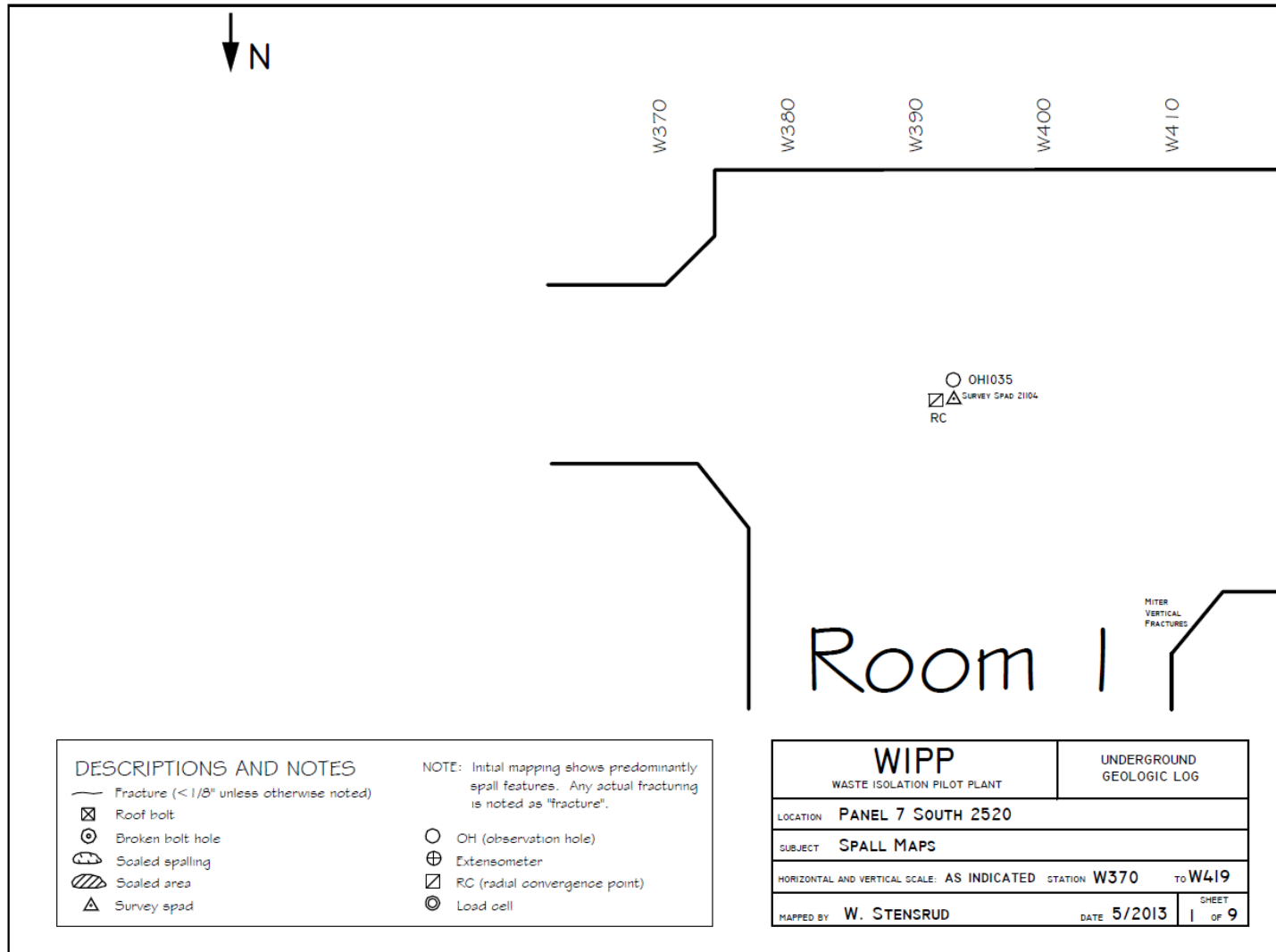

Figure 7-38
Panel 7 South 2520, W370-S419 Roof Fractures

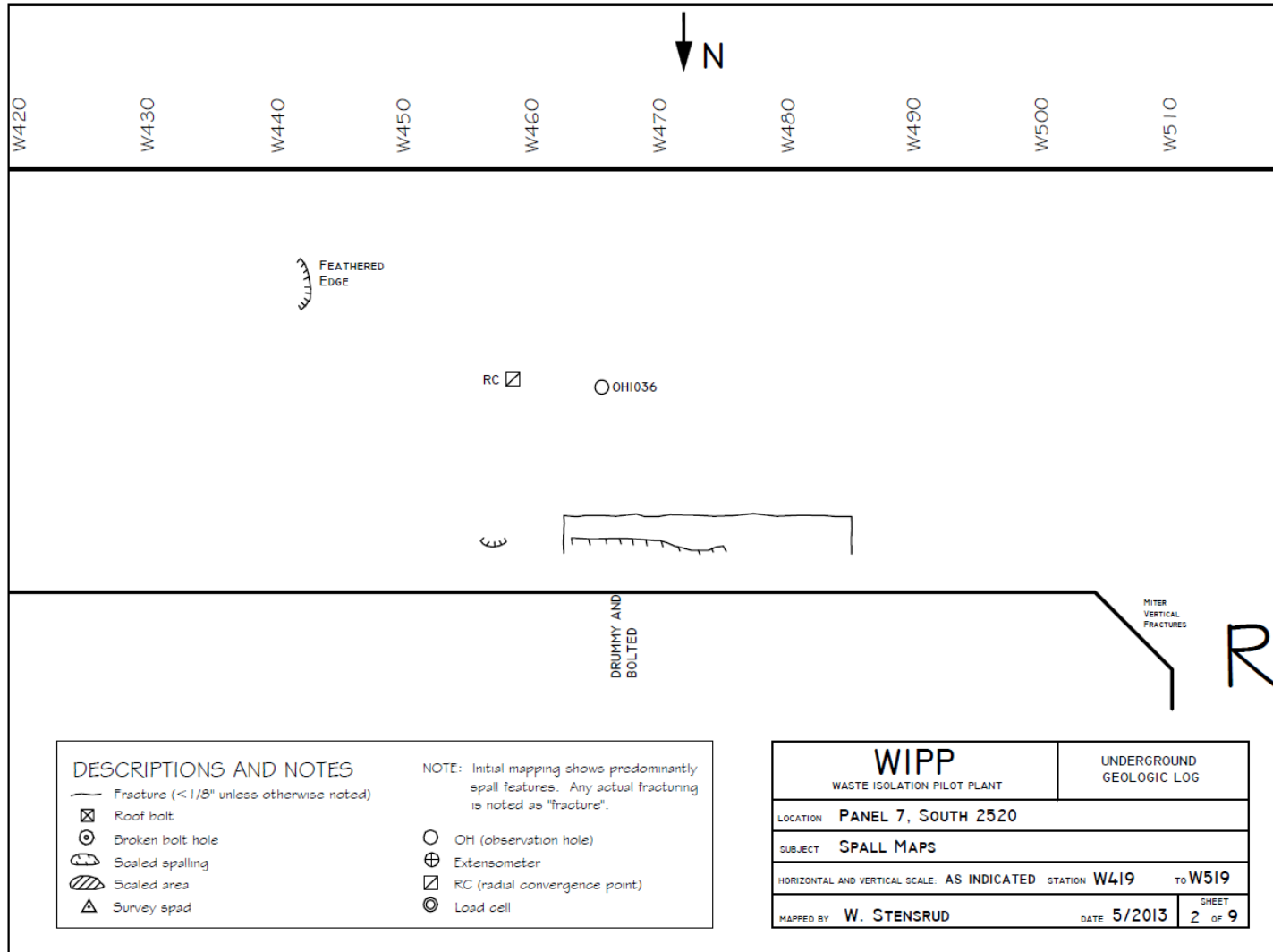

Figure 7-39
Panel 7 South 2520, W419-W519 Roof Fractures

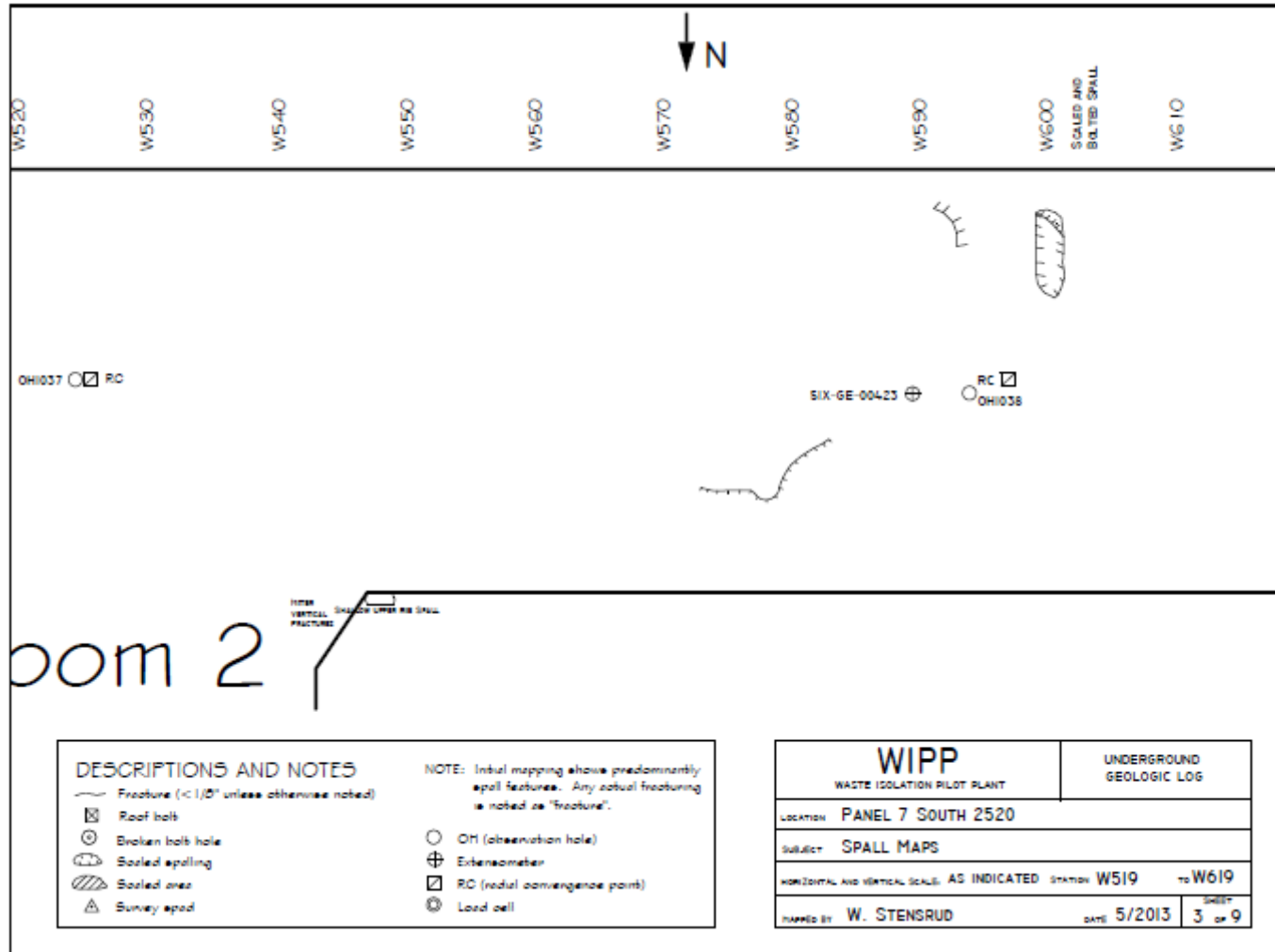

Figure 7-40
Panel 7 South 2520, W519-W619 Roof Fractures

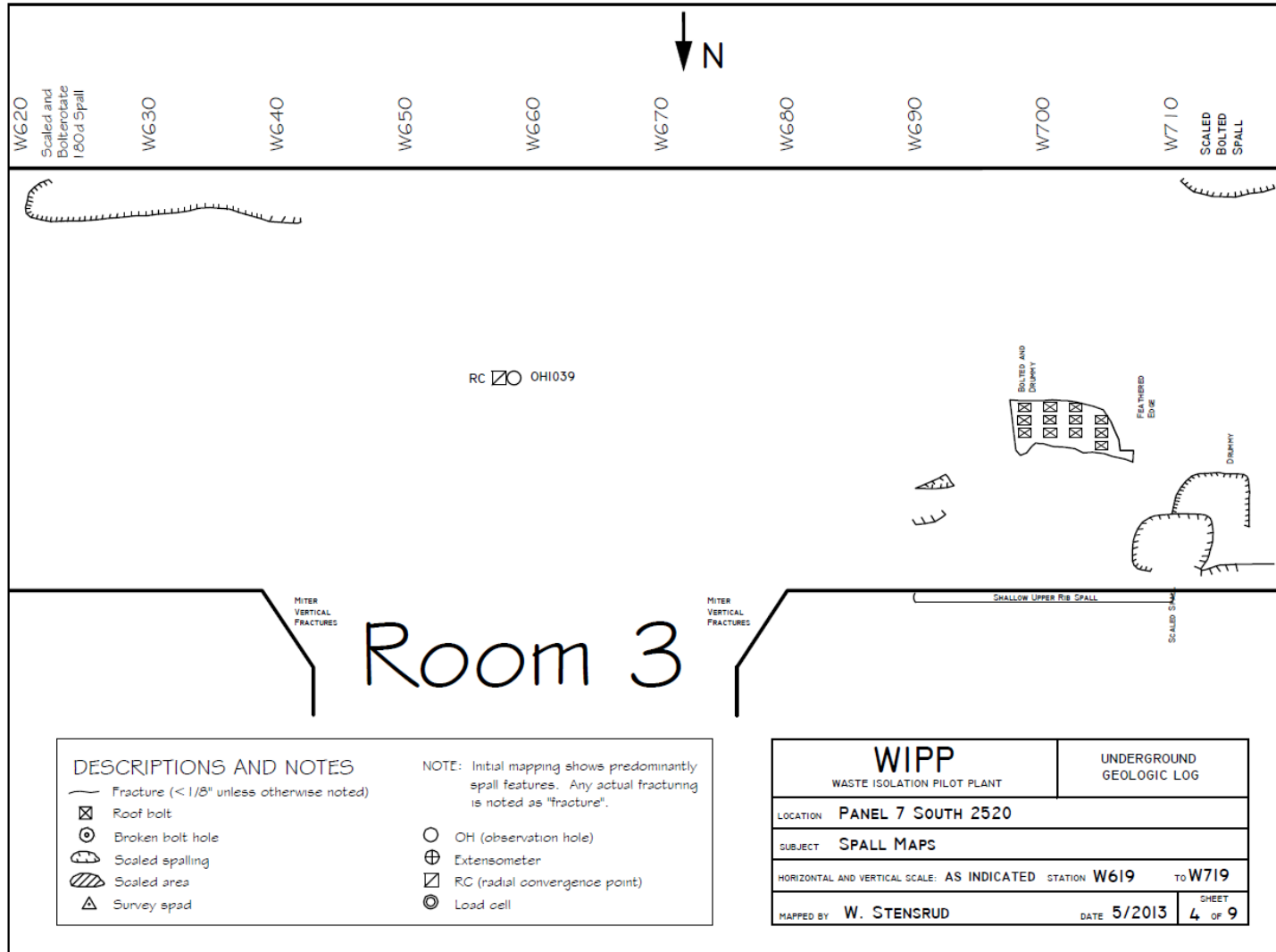

Figure 7-41
Panel 7 South 2520, W619-W719 Roof Fractures

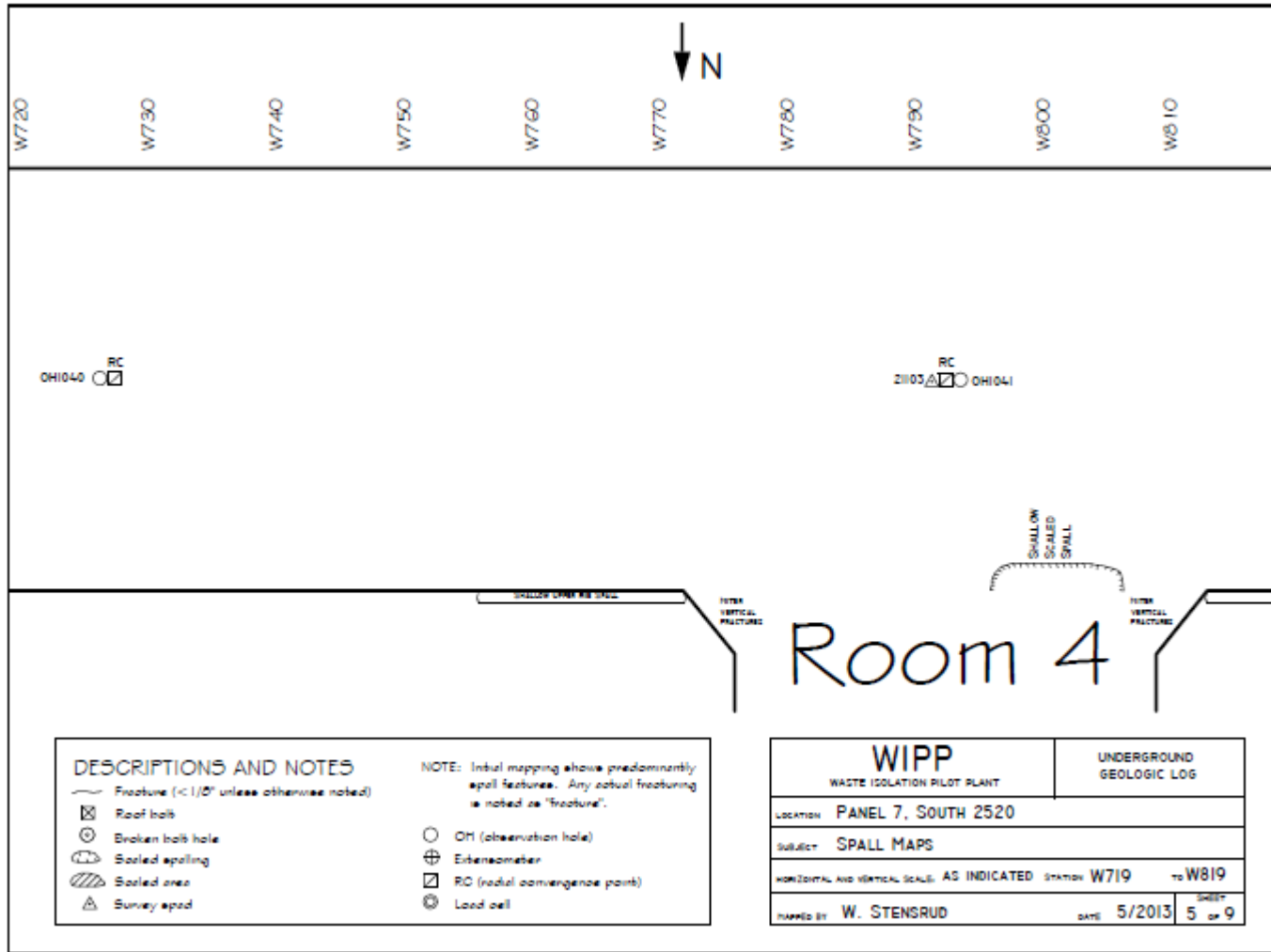

Figure 7-42
Panel 7 South 2520, W719-W819 Roof Fractures

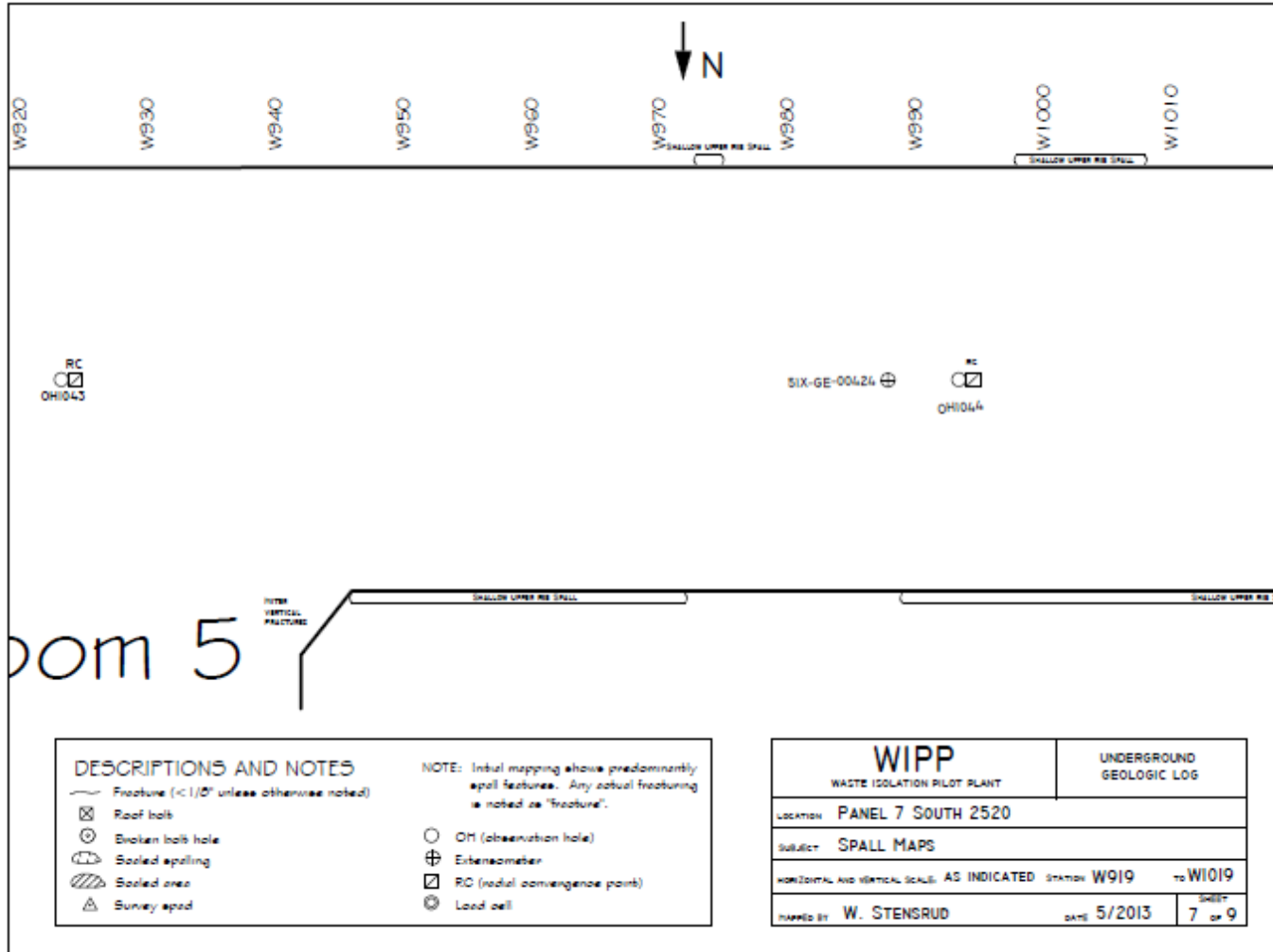

Figure 7-44
Panel 7 South 2520, W919-W1019 Roof Fractures

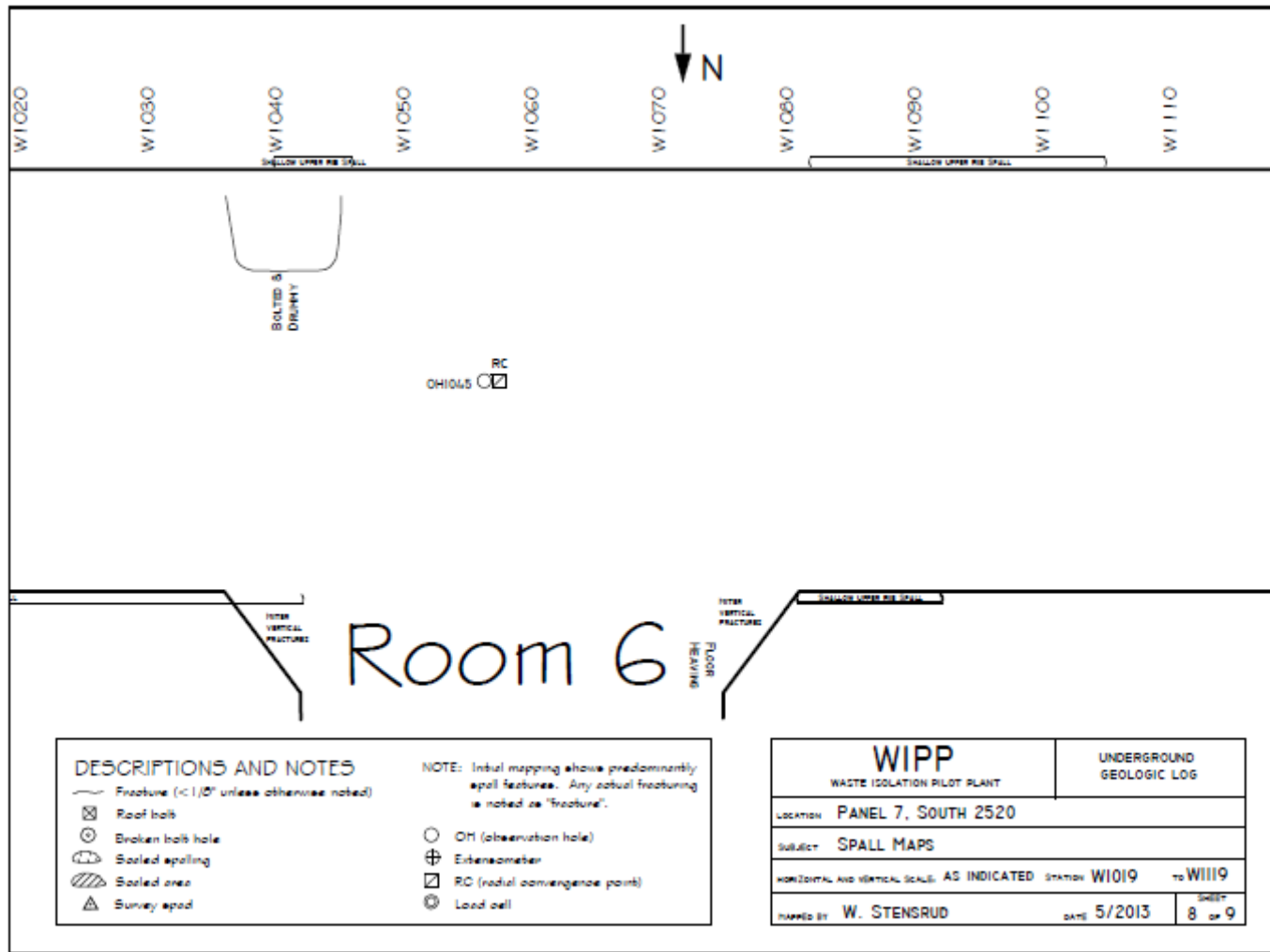

Figure 7-45
Panel 7 South 2520, W1019-W1119 Roof Fractures

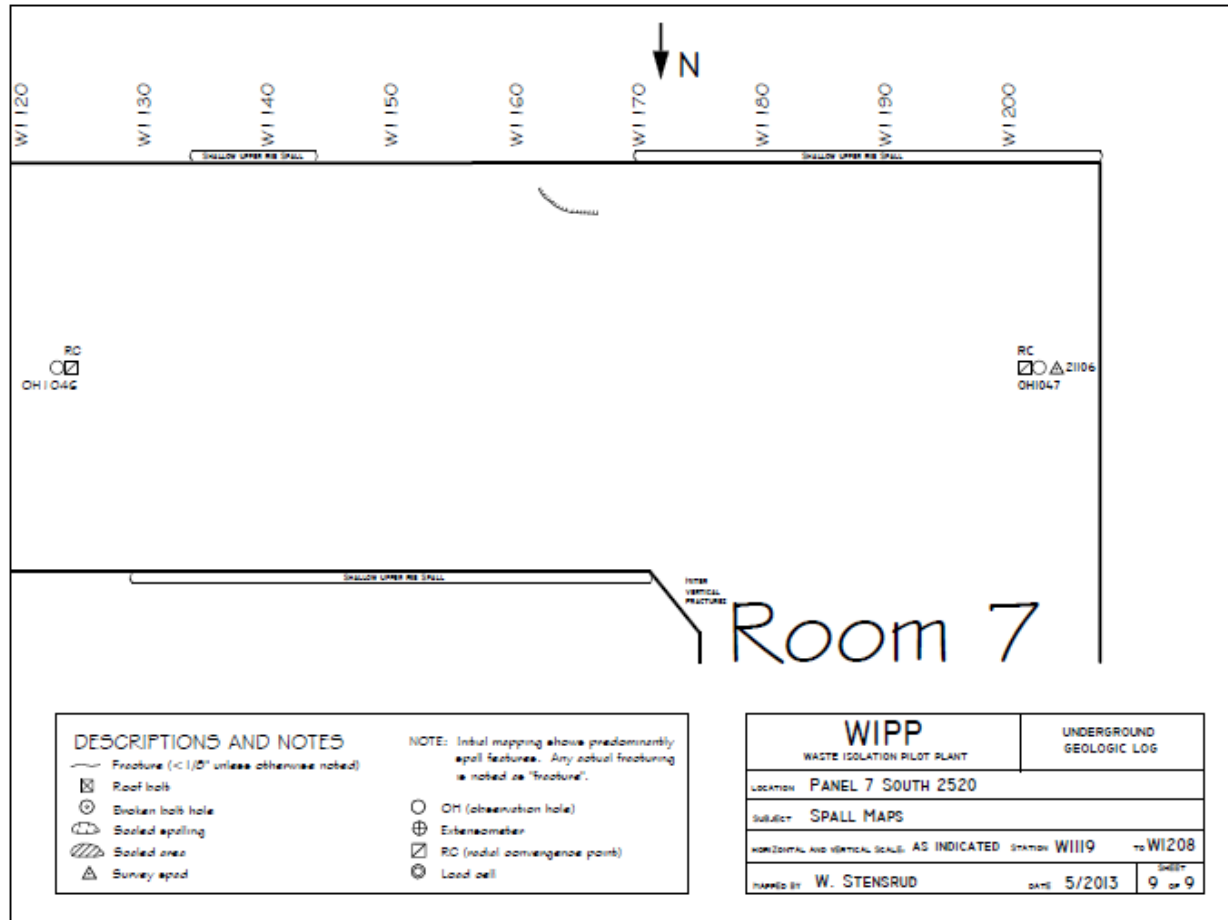

Figure 7-46
Panel 7 South 2520, W1119-W1208 Roof Fractures